

CREDENZE E MADIE / SIDEBOARDS
TAVOLI / TABLES
SEDIE / CHAIRS
SCRITTOI / WRITING DESK



Alf DaFre®

CREDENZE E MADIE / SIDEBARDS
TAVOLI / TABLES
SEDIE / CHAIRS
SCRITTOI / WRITING DESKS

Alf DaFre®

Index

Credenze e madie / Sideboards and cabinets



GIOBERG
pag. 006



GUBIA CREDENZA
pag. 016



DAMA
pag. 024



RIGADIN
pag. 034



KENDO
pag. 044



MUSA
pag. 052



RECTA
pag. 068

Sistemi credenze e madie / Sideboard and cabinet compositions



DIKO
pag. 084



METROPOLIS
pag. 106



DA-DO GIORNO
pag. 126

Tavoli / Tables



ESSE fisso / fixed
pag. 142



POLS fisso / fixed
pag. 160



GUBIA TAVOLO fisso / fixed
pag. 168



ADAMO allungabile / extendable
pag. 176



JAG allungabile / extendable
pag. 190

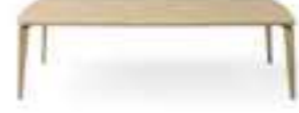

FYRA fisso o allungabile / fixed or extendable
pag. 200



RIGADIN fisso / fixed
pag. 212



FUSELLO fisso / fixed
pag. 222



CARTESIO allungabile / extendable
pag. 232

Scrivani / Writing desks



YUKIO
pag. 240



STIKS
pag. 254



TINA
pag. 260



CORIUM
pag. 266



KAROL / KAROL WOOD
pag. 274



RAKU
pag. 280



SHIFT
pag. 286

Sedie / Chairs

IT Credenze e madie come elementi d'arredo e di vita, capitoli di una storia quotidiana che continua nel tempo e nello spazio. Progetti originali nell'ispirazione e nella personalità, pensati per caratterizzare lo spazio domestico e per armonizzarsi con gli stili, i desideri e le esigenze delle persone che vi abitano.

EN Sideboards and cabinets as furniture and lifestyle elements, chapters in a daily story that continues through time and space. Original designs with inspiration and personality, conceived to characterise domestic space and create harmony with the styles, intentions and needs of those who inhabit it.

- 006 Gioberg
- 016 Gubia credenza
- 024 Dama
- 034 Rigadin
- 044 Kendo
- 052 Musa
- 068 Recta
- 084 Diko
- 106 Metropolis
- 126 Da-Do ^{giorno}



Gioberg

Ispirata al grattacielo Pirelli di Giò Ponti, la madia Gioberg si impone con la sua scultorea presenza. Le sue forme rastremate permettono di collocarla anche a centro stanza dove diventa protagonista dell'ambiente. La possibilità di personalizzare le finiture delle ante e del piano con diverse tonalità crea suggestivi effetti cromatici.

Inspired by the Pirelli skyscraper by Giò Ponti, the Gioberg cabinet has an imposing sculptural presence. Its tapered lines mean it can also be placed in the middle of the room as a true centre piece. Different finishes can create chromatic effects.

design Gordon Guillaumier





Gioberg credenza / sideboard
Laccato micalizzato Nickel e Laccato Modica lucido / Micalised Nickel laquer and High gloss Modica lacquer
L/W200,2 P/D51,8 H 78,3

Sobi poltrona / armchair
Tessuto Ricciolone 01/2 / Ricciolone 01/2 fabric
L/W87 P/D85 H71

Tsuki tavolino / occasional table
Struttura verniciato moka shine, Piano vetro bronzo satinato / Structure painted in Moka Shine / Satin-finish bronze glass top
L/W104,5 P/D76,8 H35



Gioberg credenza / sideboard
Laccato Anfora lucido, top laccato Azalea
lucido / High gloss Anfora lacquer, top
high gloss Azalea laquer
L/W200,2 P/D51,8 H78,3

Disco specchiera / mirror
Cornice Moka shine / Moka shine frame
L/W99,5 P/D4 H99,5



Gioberg credenza / sideboard
 Laccato Anfora lucido e Azalea opaco
 / High gloss Anfora lacquer and matt
 Azalea lacquer
 L/W200,2 P/D51,8 H 78,3





GIOBERG

design Gordon Guillaumier

Registered design

Gioberg è una credenza con 4 ante. L'abbinamento tra due tinte laccate permette giochi di colore tra frontali e top/interno. È dotata di cerniere ammortizzate a scomparsa.

Materiali e finiture

Top: Laccati opachi, Laccati lucidi, Laccati micalizzati.

Scocca esterna: Laccati opachi, Laccati lucidi, Laccati micalizzati.

Scocca interna: segue la finitura del top, nel caso di top laccato lucido la scocca è laccata opaca nello stesso colore.

Gioberg is a sideboard with 4 doors. Combine two lacquer shades to have fun with colour across the fronts and tops/interiors. The unit is equipped with concealed soft-close hinges.

Materials and finishes

Top: Matt lacquer, high-gloss lacquer, micalised lacquer.

External structure: Matt lacquer, high-gloss lacquer, micalised lacquer.

Internal structure: follows the finish of the top, in the case of a glossy lacquered top the structure is matt lacquered in the same color.

Credenza / Sideboard

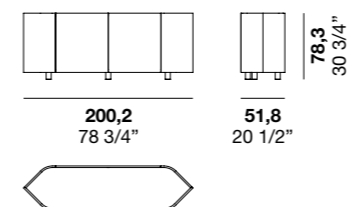

Gioberg credenza / sideboard
Laccato Amaranto lucido / High gloss
Amaranto lacquer
L/W200,2 P/D51,8 H 78,3

Gubia credenza

Volumi geometrici scolpiti sulla superficie: una credenza che esprime al suo interno le origini artigianali delle lavorazioni. Una re-interpretazione delle radici e del know-how in un design iconico che caratterizza gli interni contemporanei.



Geometric volumes sculpted on the surface: a sideboard that embodies the handcrafted origins of workmanship within. A re-interpretation of roots and know-how in an iconic design that characterizes contemporary interiors.

design Gordon Guillaumier







I cassetti sono arricchiti da eleganti tappetini in ecopelle. / The drawers are enriched with elegant eco-leather mats.

Gubia credenza / sideboard
Fashion wood rovere Terra e basamento
Elettrocol raggrinzante / Fashion wood
terra oak and Elettrocol raggrinzante
basement
L/W207,1 P/D49,6 H81,8

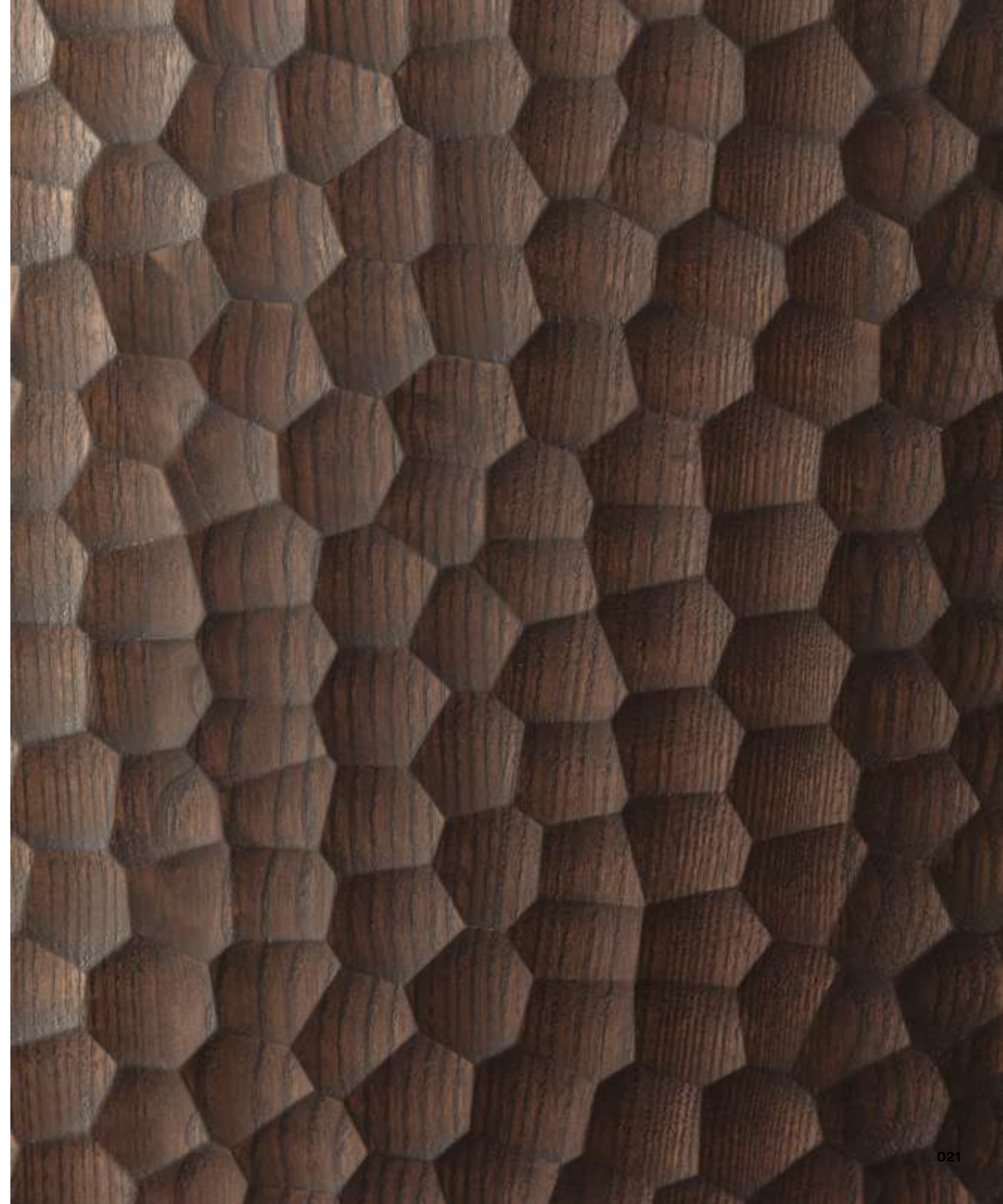



GUBIA

design Gordon Guillaumier

design depositato

Struttura in Fashion wood Rovere terra. Base in metallo verniciato Elettrocol raggrinzante, per un effetto più materico della superficie. Disponibile versione retro-finita.

Frame in Terra oak Fashion Wood. Base made of Elettrocol-painted metal, for a more textured surface effect. Available in a retro-finished version.

Materiali e finiture

Struttura e piano: Fashion wood Terra.

Materials and finishes

Structure and top: Terra Fashion Wood.

Credenza / Sideboard

Credenza retro finita / Sideboard finished back

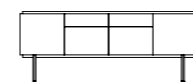

207,1
81 1/2"

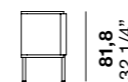

49,6
19 1/2"

81,8
32 1/4"

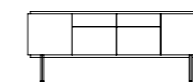

207,1
81 1/2"

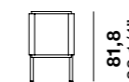

52,6
20 3/4"

81,8
32 1/4"

Dama

Dama è un gioco di geometrie tridimensionali che ricrea l'effetto di una scacchiera immaginaria sull'anta. Un complemento d'arredo raffinato nel concetto e nell'esecuzione, originale nell'estetica che unisce il pieno e il vuoto in un'unica emozione.

Dama uses interplay of 3D forms for an imaginary chessboard effect on its door. This piece is refined in concept and execution, with an original aesthetic that combines volumes and empty space in a single impact.

design R&D Alf DaFrè





Dama credenza / sideboard
Noce naturale e basamento nickel / Natural
walnut and Nickel basement
L/W207,8 P/D52,2 H78



Dama credenza / sideboard
 Noce naturale e basamento nickel,
 top ceramica Neolith Himalaya crystal
 ultrasoft / Natural walnut and Nickel
 basement, Neolith Himalaya crystal
 ultrasoft ceramic top
 L/W207,8 P/D52,2 H78

Jag tavolo / table
 Top ceramica neolith Himalaya Crystal
 ultrasoft, struttura Nickel/ Neolith Crystal
 ultrasoft ceramic top, nickel structure
 L/W181 P/D95 H74,7

Corium sedia / chair
 Cuoio naturale/ Natural leather
 L/W50,5 P/D55 H80



Dama credenza / sideboard
Noce naturale e basamento nickel / Natural
walnut and Nickel basement
L/W207,8 P/D52,2 H78

DAMA

design R&D Alf DaFrè



Dama è caratterizzata dalla finitura tridimensionale dell'anta che aggiunge un pregiato effetto decorativo alla credenza. Dettagli particolari sono anche l'apertura angolare delle ante laterali e la gola superiore creata dal leggero atterramento del piano rispetto alla geometria del mobile. Personalizzabile con top in Noce oppure in diverse ceramiche offre combinazioni materiche ogni volta inedite.

Materiali e finiture
Top: Noce, Ceramiche.
Scocca esterna: Noce.
Scocca interna: Nobilitato pelle crema.

Dama is distinguished by the 3D finish on the door, which adds a refined decorative effect to the sideboard. Other unusual details are the angled opening of the side doors and the upper groove created by a slightly lowered top in relation to the unit's geometric form. It can be customised with a Walnut top or various ceramic finishes, ensuring unique textural combinations.

Materials and finishes
Top: Walnut, Ceramics.
External structure: Walnut.
Internal structure: Crema leather surfaced.

Credenza / Sideboard

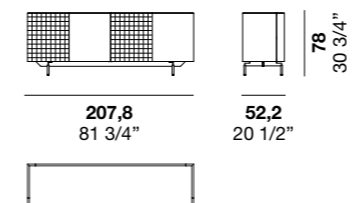

Ceramiche per top / Top ceramics

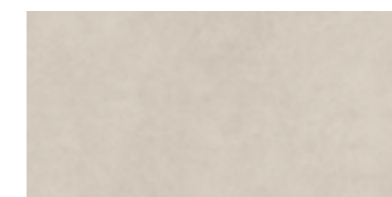

Laminam Fokos Sale

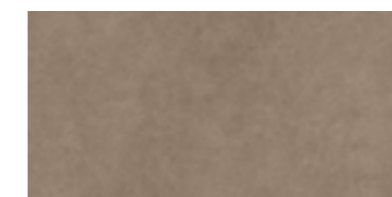

Laminam Fokos Terra

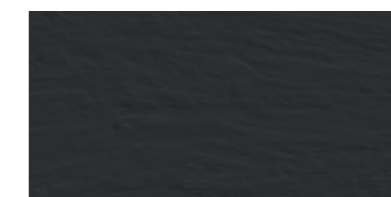

Laminam Ardesia a Spacco



Laminam bianco Statuario Venato Lucidato



Laminam Sahara Noir Extra Lucidato



Neolith Himalaya Crystal Ultrasoft



Neolith Amazonico Polished

Rigadin

Il legno massello, con il suo fascino artigianale e calore naturale, è l'essenza di Rigadin. Stile contemporaneo e matericità ancestrale, si fondono in un unico progetto di design. Il top in pietra o metallo segue le sue forme morbide e la sua ispirazione profonda.

Solid wood, with its artisan charm and natural warmth, is the very essence of Rigadin. Contemporary style and ancestral textures fuse in a unique design. The stone or metal top echoes its soft lines and deep inspiration.

design Gordon Guillaumier



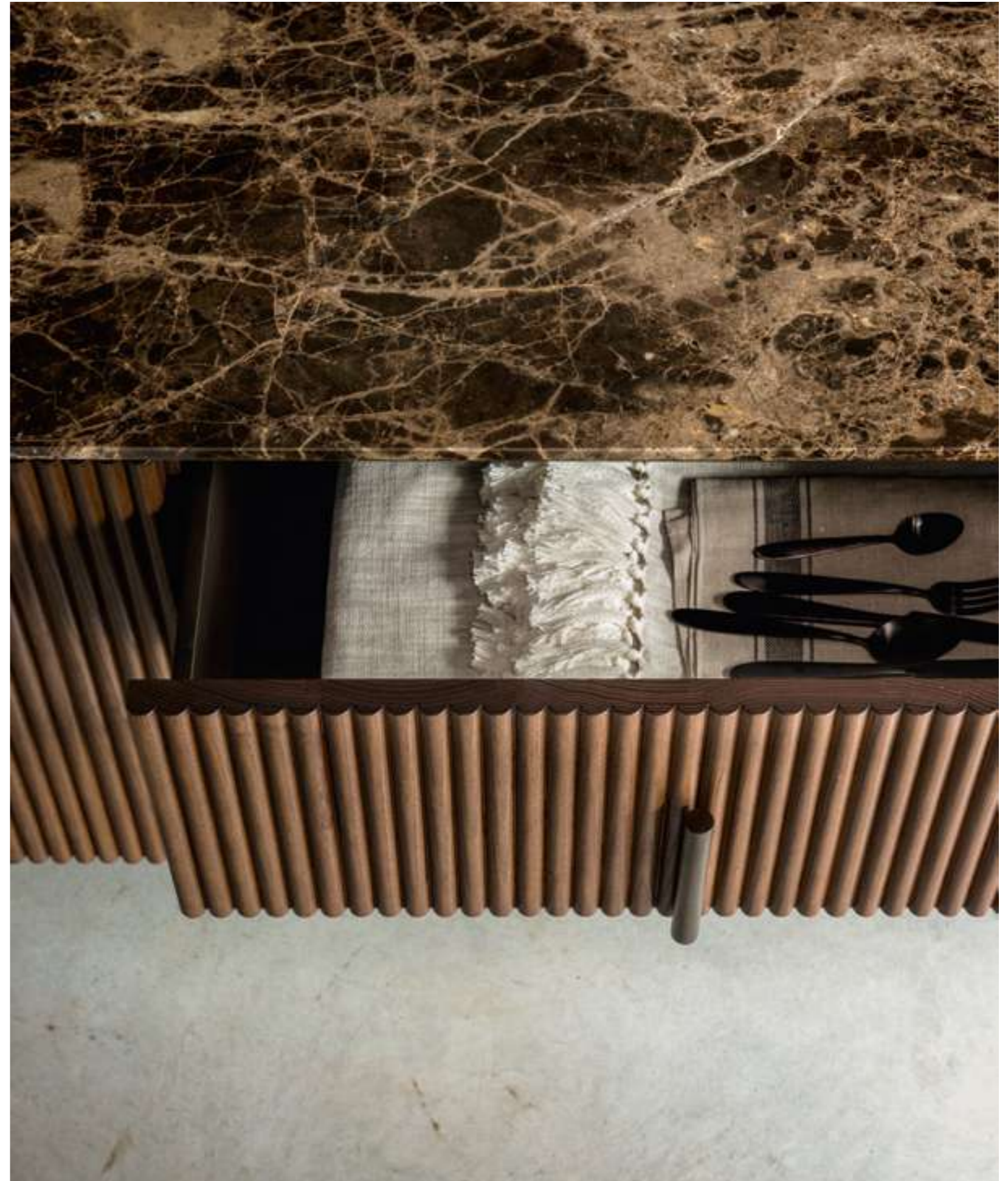



Rigadin credenza / sideboard
Top marmo Marron emperador lucido /
Gloss Marron emperador marble top
L/W192,1 P/D47,6 H72,7



Rigadin credenza / sideboard
Top metallo / metal top
L/W192,1 P/D47,6 H71,8





RIGADIN

design Gordon Guillaumier

Il legno massello è l'essenza di Rigadin. Una collezione preziosa e vera, dove la bellezza è forma ma anche sostanza. Pregio ed essenzialità sono plasmati in modo personale, connessi da ispirazione e artigianalità. Disponibile in versione con top metallo o marmo / pietra.

Materiali e finiture
 Piano: Marmo, Pietra, Metallo verniciato elettrocol raggrinzante.
 Struttura: Frassino tinta noce.
 Basamento e maniglie: Metallo verniciato elettrocol raggrinzante.

Solid wood is the essence of Rigadin. A fine, authentic collection, where beauty is substance as well as form. Quality and simplicity are moulded to measure, at one in their inspiration and craftsmanship. Available with metal or marbles/stones version.

Materials and finishes
 Top: textured "Elettrocol" painted metal, marble or stone.
 Structure: Walnut tinted ash.
 Basement: textured "Elettrocol" painted metal.

Top metallo / Metal top

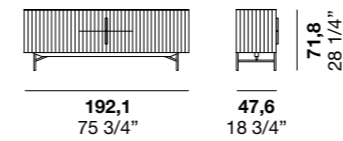

Top marmo-pietra / Top marble-stone

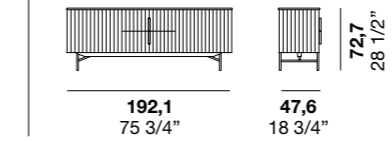

Marmi-Pietre per top / Top marbles-stones



Emperador Lucido



Emperador Spazzolato



Pietra Lavica Spazzolata



Infinity



Camouflage

Kendo

Come il taglio di una lama che fende l'aria, la linea diagonale sulle ante di Kendo crea un dinamico gioco di piani lievemente sfalsati, per un suggestivo gioco di luci e ombre. Il suo design unico, ispirato all'arte orientale della spada, è infinitamente personalizzabile nelle finiture, anche con abbinamenti bicolori.

Like a blade cutting through the air, the diagonal line on the doors of Kendo create a dynamic dialogue with slightly offset levels, for an evocative interplay of light and shadow. Its unique design, inspired by the oriental art of swordplay, has endless finishes, including two-colour options.

design Meneghello Paoletti Associati





Esagona specchiera / mirror
Cornice Moka Shine / Moka Shine frame
L/W80 P/D5 H69,3

Kendo credenza / sideboard
Struttura Fashion wood rovere Fossile,
ante laccato lucido Modica / Fashion wood
Fossile oak structure, doors in high gloss
Modica laquered
L/W210 P/D50 H78

Raku sedia / chair
Pelle Lord 9120 / Lord 9120 leather
L/W54,3 P/D55 H78

Fyra tavolo / table
Fashion wood rovere Carbone / Fashion
wood Carbone oak
L/W200 P/D100 H75,4





Kendo credenza / sideboard
Struttura Fashion wood rovere Fossile, ante
laccato Nickel micalizzato / Fashion wood
Fossile oak structure, Micalised Nickel doors
L/W210 P/D50 H78



KENDO

design Meneghello Paoletti Associati

Kendo è una credenza caratterizzata da un particolare gioco geometrico delle ante: ciascuna anta presenta un taglio a 30° che la divide in due parti non perfettamente complanari ma lievemente disassate, regalando alla superficie un raffinato effetto di chiaroscuro. Kendo è proposto nelle finiture nobilitate, Fashion wood e laccati. È eventualmente disponibile anche con ante, struttura e top in finiture o colore differenti.

Materiali e finiture
 Basamento in metallo: verniciato Moka Shine.
 Struttura e frontali: Nobilitati, Fashion wood, Rovere laccati opachi, Laccati opachi e lucidi, Laccati micallizzati.

Kendo is a sideboard with unusual geometric doors: each one has a 30° cut that divides it into two parts that are not on exactly the same plane but instead slightly off -centre, lending the surface a refined light and shade effect. Kendo is available in a surfaced, Fashion Wood or lacquer finish. It is also available with the doors, frame and top in different finishes or colours.

Materials and finishes
 Metal base: Painted Moka Shine.
 Framework and fronts: Surfaced, Fashion Wood, Matt lacquer oak, Matt and high-gloss lacquers, Micalised lacquered.



Credenza / Sideboard



Musa

Volumi arrotondati e linee diagonali, caratterizzano Musa creando una sensazione di inconfondibile eleganza. La scocca appare come una superficie unica, senza giunture, mentre le prese delle ante sono nascoste dai profili inclinati: l'essenziale è invisibile agli occhi.

Rounded forms and diagonal lines characterise Musa at first sight, for unmistakable elegance. The structure appears to be a single surface, without joints, while the handles on the doors are concealed with slanted profiles: minimalist and hidden from view.

design Marelli & Molteni



Musa credenza / sideboard
Ante Nickel spazzolato, scocca Fashion
wood Rovere Fossile, basamento Moka
Shine e interno laccato Piombo / Brushed

Nickel doors, Fashion wood Fossile oak
structure, Moka Shine basement and
lacquer Piombo interior
L/W220 P/D52,7 H75



Musa credenza / sideboard
Ante Piombo spazzolato, scocca Fashion wood Rovere Fossile, basamento Moka Shine e interno laccato Piombo / Brushed Piombo doors, Fashion wood Fossile oak structure, Moka Shine basement and lacquer Piombo interior
L/W220 P/D52,7 H75

Disco specchiera / mirror
Cornice Moka shine / Moka shine frame
L/W99,5 P/D4 H99,5





Musa credenza / sideboard
Ante Nickel spazzolato, scocca Fashion wood Rovere Fossile, basamento Moka Shine e interno laccato Piombo / Brushed Nickel doors, Fashion wood Fossile oak structure, Moka Shine basement and lacquer Piombo interior
L/W220 P/D52,7 H75



Musa credenza / sideboard
Ante Piombo spazzolato, scocca Fashion wood Rovere Fossile, basamento Moka Shine e interno laccato Piombo / Brushed Piombo doors, Fashion wood Fossile oak structure, Moka Shine basement and lacquer Piombo interior
L/W220 P/D52,7 H75



Musa

Credenze e madie / Sideboards and cabinets



Musa credenza / sideboard
Laccato opaco Cuoio naturale e basamento
Moka shine / Cuoio naturale matte lacquer
and Moka shine basement
L/W220 P/D52,7 H75

Adamo tavolo / table
Fashion wood Rovere Carbone / Fashion
wood Carbone oak
L/W200 P/D100 H76,4

Corium sedia / chair
Cuoio naturale / Natural leather
L/W50,5 P/D55 H80





Musa madia / cabinet
Fashion wood Rovere Fossile, vano Laccato
Nude opaco / Fossile oak Fashion wood,
glass compartment Matt Nude lacquer
L/W130 P/D52,7 H145

Musa base TV / TV base
Fashion wood Rovere Fossile / Fossile oak
Fashion wood
L/W175 P/D52,7 H50



Musa madia / cabinet
 Laccato opaco Arena, interno laccato opaco Cuoio naturale e basamento Moka shine/ Matt lacquer Arena, matt lacquer interior Cuoio naturale and Moka shine basement
 L/W130 P/D52,7 H145

MUSA

design Marelli & Molteni

Musa è disponibile in versione credenza, madia o vetrina e si distingue per le forme arrotondate della scocca e per il taglio inclinato delle ante che celano la maniglia e proseguono nelle linee dei piedi in metallo verniciato. L'interno può essere laccato e dotato, nel caso della credenza, di una pratica cassettera.

Materiali e finiture

Struttura: Fashion wood, Roveri laccati opachi, Laccati opachi e lucidi, Laccati micalizzati.
 Frontali: Fashion wood, Roveri laccati opachi, Laccati opachi e lucidi, Laccati micalizzati, Laccati spazzolati.
 Scocca interna: Nobilitato pelle crema, Laccati opachi, Laccati micalizzati.

Musa is available in the sideboard, cabinet or display cabinet version and it stands out for the rounded shapes of the body and the inclined cut made on the doors that conceal the handle and continue in the silhouette of the painted metal feet. The interior can be lacquer and fitted - in the sideboard version - with a practical drawer unit.

Materials and finishes

Structure: Fashion wood, Matt lacquered oak, Matt or high gloss lacquer, Micalised lacquer.
 Fronts: Fashion wood, Matt lacquered oak, Matt or high gloss lacquer, Micalised lacquer, Brushed lacquer.
 Internal structure: Crema leather surfaced, matt lacquered, Micalised lacquer.

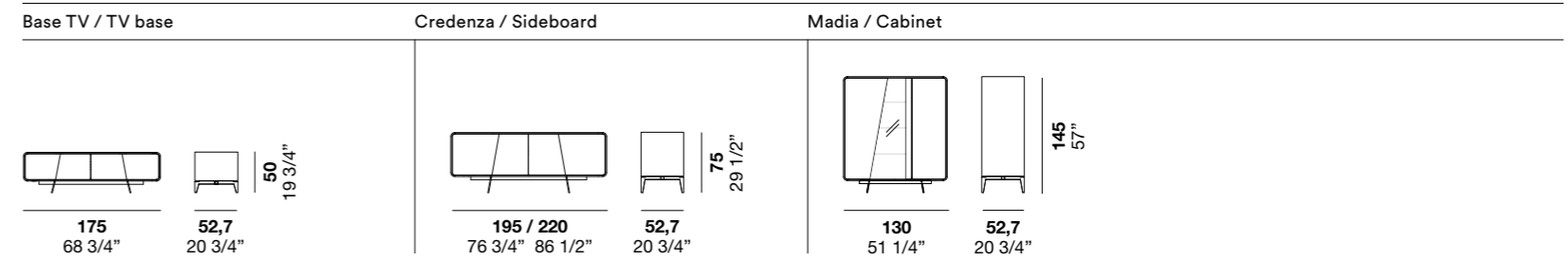

Recta

Forma e funzione trovano una sintesi totale in Recta: i pannelli divisori fra gli elementi assolvono il compito di sostenere il suo volume essenziale, diventando essi stessi degli elementi di design. Una vasta scelta di moduli e finiture, permette di comporre innumerevoli soluzioni.

Form and function find complete synthesis in Recta. Partition panels between elements offer support to the minimalist structure, becoming design elements in their own right. A vast selection of units and finishes enable limitless solutions.

design Marelli & Molteni





Recta credenza / sideboard
Laccato lucido Curcuma, interno nobilitato
pelle Crema / High gloss Curcuma lacquer
and Surfaced Crema lacquer interior
L/W186,8 P/D55 H78,2

Alf DaFrè



Recta

Credenze e madie / Sideboards and cabinets



Sobi divano / sofa
Tessuto Made F19/ Made F19 fabric
L/W258 P/D91 H71

Recta composizione / composition
Laccato fango lucido/ High gloss Fango
lacquer
L/W441,2 P/D49 H43

Tsuki tavolini / occasional tables
Struttura verniciato Moka shine e piano
vetro bronzo satinato / Structure Moka
shine painted and satin finish bronze
glass top

L/W101,7 P/D99,8 H28
L/W104,5 P/D76,8 H35
L/W60 P/D54,3 H42



Recta credenza / sideboard
Laccato opaco Anfora/ Matt lacquer
Anfora
L/W216,8 P/D55 H78,2

Olivia poltrona / armchair
Tessuto Nina 06 / Nina 06 fabric
L/W106 P/D93 H89
L/W68 P/D49 H41

Tsuki tavolino / occasional tables
Struttura verniciato Moka shine e piano
vetro bronzo satinato/ Structure Moka shine
painted and satin finish bronze glass top
L/W60 P/D54,3 H42





Recta credenza / sideboard
Fashion wood rovere Carbone e interno laccato
opaco Sahara / Fashion wood Carbone oak and
matte Sahara lacquer interior
L/W246,8 P/D55 H78,2





RECTA

design Marelli & Molteni

Recta è disponibile in versione credenza, madia e libreria. Recta crea contrasti cromatici tra i frontali di ante e cassetti e la sua struttura in cui le divisioni fungono anche da basamento. Le ante centrali di madie e credenze hanno un'apertura totale a 180°. Ampia la modularità e le conformazioni con la possibilità della laccatura interna.

Materiali e finiture
 Struttura e frontali: Fashion wood, Roveri laccati opachi, Laccati opachi e lucidi, Laccati micalizzati.
 Scocca interna: Nobilitato pelle crema, Laccati opachi.

Recta is available in the sideboard, cabinet and bookcase version. Recta creates colour contrasts between the door and drawer fronts and its structure, where the partitions also act as a base. The central doors of the cabinet and sideboard have a total aperture of 180°. Excellent modularity and configuration possibilities, with internal lacquering available.

Materials and finishes
 Structure and fronts: Fashion wood, Matt lacquered oak, Matt or high gloss lacquer, Micalised lacquer.
 Internal structure: Crema leather surfaced, matt lacquered.

Base TV / TV base

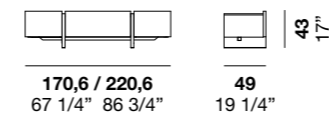

Credenza / Sideboard

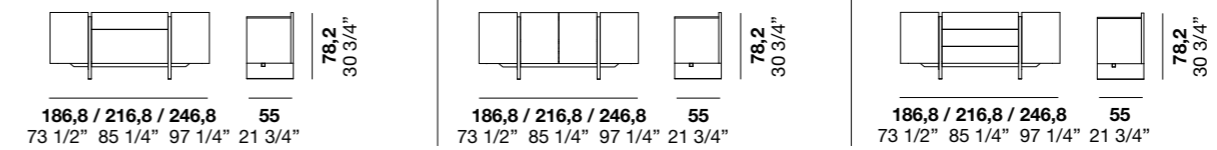

Madia / Cabinet

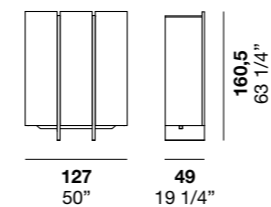

Diko

Versatilità, indipendenza, funzionalità: questi sono i valori espressi dalla madia Diko, con uno stile unico che si presta a infinite variazioni e soluzioni. Proposta con ante, cassetti o cesti, anche con ripiano in vetro, può cambiare stile e personalità a seconda delle finiture.

Versatility, independence and functionality: these are the values captured by the Diko sideboard, with its unique style that is perfect for limitless variations and solutions. Available with doors, drawers or compartments, also with a glass shelf, it alters style and personality based on the selected finishes.

design R&D Alf DaFrè





Diko credenza / sideboard
 Fashion wood Rovere Carbone con
 basamento Moka shine / Fashion wood
 Carbone oak and Moka shine basement
 L/W194,8 P/D45,4 H67



Jag tavolo / table
 Piano Fashion wood Rovere Carbone
 e struttura Moka shine/ Fashion wood
 Carbone oak top and Moka shine structure
 L/W181 P/D95 H74,7

Corium sedia / chair
 Cuoio 1031/ Leather 1031
 L/W50,5 P/D55 H80

Diko credenza / sideboard
Laccato Modica lucido con basamento
Moka shine / High gloss Modica and Moka
shine basement
L/W194,8 P/D45,4 H67

Denny pouf
Ecopelle Time 800 / Eco-leather Time 800
L/W85 P/D85 H37

Ladigue divano / sofa
Tessuto Taiga 0190-03 / Taiga 0190-03
fabric





Diko credenza / sideboard
 Fashion wood Rovere Fossile con
 basamento Moka shine / Fashion wood
 Fossile oak and Moka shine basement
 L/W256 P/D53,8 H83





Diko credenza / sideboard
Laccato opaco Petrolio con basamento
verniciato Moka Shine, Pensili laccato
opaco Petrolio e Fashion wood rovere
Carbone / Lacquer in matt Petrolio and

basement Moka Shine painted
Wall units lacquer in matt Petrolio and
Carbone oak Fashion wood
L/W389,6 P/D54,1 H179



Diko madia / cabinet
 Fashion wood Rovere Fossile, interno
 laccato Amaranto e basamento Nickel
 / Fossile oak fashion wood, Amaranth
 lacquer interior and Nickel basement
 L/W98,8 P/D45,7 H131

Raku sedia / chair
 Tessuto Nodone A1304 e struttura Moka
 shine/ Nodone A1304 fabric and Moka
 shine structure
 L/W55,5 P/D55 H80

Yukio scrittoio / desk
 Fashion wood Rovere Carbone e struttura
 Anfora opaco/ Fashion wood Carbone
 Oak and matt Anfora structure
 L/W142,3 P/D62,5 H79,8



Diko madia / cabinet
Laccato opaco Amaranto e basamento
Moka shine/ Amaranto matte lacquer and
Moka shine basement
L/W98,8 P/D45,7 H131

Lisa poltrona / armchair
Tessuto Iris 406/ Iris 406 fabric
L/W89 P/D94,5 H92

Wok tavolini / occasionale tables
Laccato Platino opaco, Laccato opaco
Amaranto / Matt Platino lacquer, Amaranto
matt lacquer
L/W27,5 P/D27,5 H50



Diko madia / cabinet
Ante groove noce naturale, fianchi e top
laccato opaco Moka shine e basamento
Moka shine Interno laccato opaco Moka
shine / Natural walnut groove doors, Moka



shine matte lacquer sides and top, and
Moka shine basement, Moka shine matte
lacquer interior
L/W98,8 P/D45,7 H131





DIKO

design R&D Alf DaFrè

Il sistema si arricchisce del nuovo modulo contenitore indipendente Diko: una madia funzionale che può avere tante espressività e tante vite. Proposta nella versione a 2 o 4 ante, anche con l'aggiunta di un ripiano in vetro. L'ampia scelta di colori e finiture: rovere laccato opaco, fashion wood, laccati lucidi e laccati micalizzati la rende adatta ad ogni interno e stile.

The collection has been enhanced with the new Diko free-standing storage unit, a functional sideboard that can add a huge amount of expression and life. It is available with 2 or 4 doors, and also with the addition of a glass shelf. The wide range of colours and finishes, including matt lacquer oak, Fashion Wood, high-gloss lacquers and micalised lacquers, make it ideal for any interior or style.

Materiali e finiture

Struttura: Nobilitati, Fashion wood, Roveri laccati opachi, Laccati opachi e lucidi.
Frontali: Nobilitati, Fashion wood, Roveri laccati opachi, Laccati opachi e lucidi, Laccati micalizzati, Groove.
Scocca interna: Decor Tortora, Laccati opachi.

Materials and finishes

Structure: Surfaced, Fashion wood, Matt lacquered oak, Matt or high gloss lacquer.
Fronts: Surfaced, Fashion wood, Matt lacquered oak, Matt or high gloss lacquer, Micalised lacquer, Groove.
Internal structure: Tortora Decor, matt lacquered.

Base TV / TV base

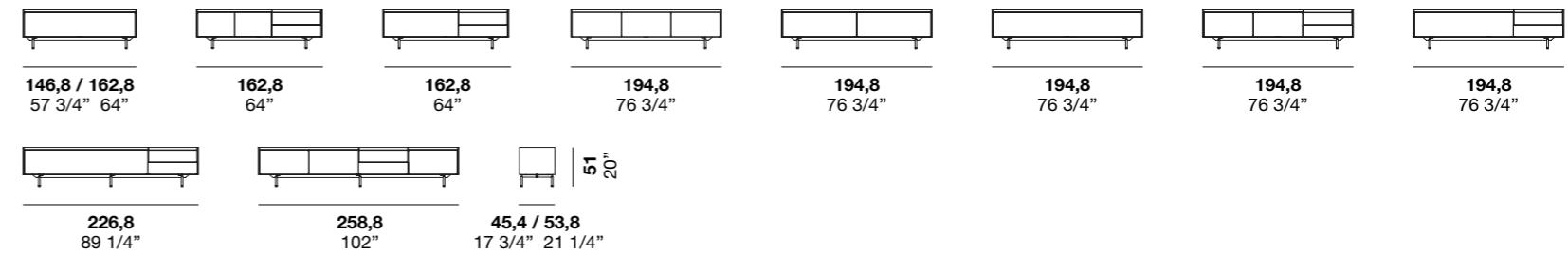

Credenze / Sideboards

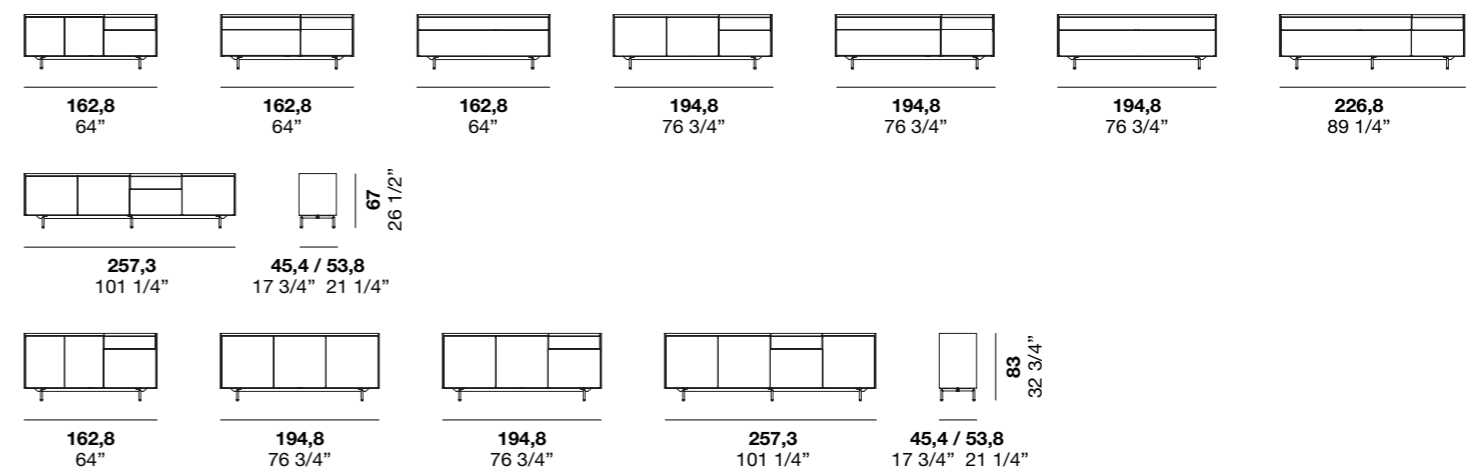

Madie / Cabinets

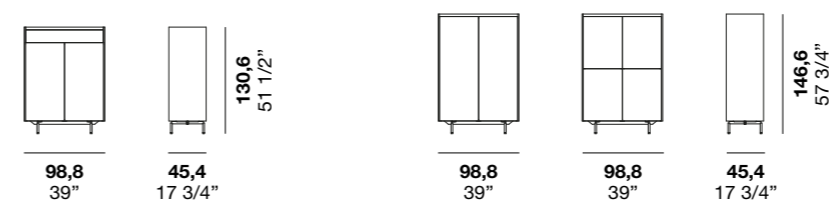

Metropolis

Contenere, esporre, arredare: Metropolis è un progetto che soddisfa tutte le esigenze nel panorama dell'abitare contemporaneo. Le sue forme lineari disegnano delle vere e proprie architetture d'arredo, in perfetta armonia con lo stile e le dinamiche dell'ambiente domestico.

Store, display and furnish: Metropolis is a design that meets all the requirements of contemporary living. Its linear shapes form truly architectural elements, in perfect harmony with the style and dynamics of the domestic environment.

design R&D Alf DaFrè





Metropolis
Fashion wood Rovere Naturale e Decato
Tricollorato in laccatura Palladio
Decorata in laccatura Palladio
L/W128 P/D52,2 H136
L/W128 P/D52,2 H136



Metropolis credenza / sideboard
Laccato lucido Piombo e vano a giorno
laccato opaco Cuoio / Piombo gloss
lacquer and open unit matte lacquer Cuoio
L/W256 P/D52,2 H88

Adamo tavolo / table
tavolo / table
Fashion wood Rovere Ghiro/ Fashion wood
Ghiro oak
L/W200 P/D100 H76,4

Karol sedia / chair
Tessuto Nodone A1311/ Nodone A1311
fabric
L/W50 P/D62 H80









Metropolis porta TV / TV base
 Laccato Tè verde lucido, vano a giorno
 Decor laccato Piombo / High gloss Tè
 verde lacquer, open compartment in Decor
 Piombo lacquer
 L/W192 P/D52,2 H50,2

Metropolis credenza / sideboard
 Laccato Blu notte opaco / Matt Blu notte
 lacquer
 L/W192 P/D52,2 H72



Metropolis credenza / sideboard
Laccato lucido Cuoio e vano a giorno
laccato opaco Cuoio/ Cuoio gloss lacquer
and open unit matte lacquer Cuoio
L/W256 P/D52,2 H88



METROPOLIS

design R&D Alf DaFrè

Metropolis è un programma di credenze, madie, vetrine e porta TV vasto e articolato in grado di soddisfare le più svariate esigenze. Dotato di ante e cassetti con chiusura assistita dispone di versioni con vani a giorno o con vetrina, top in vetro o in finitura.

Metropolis is an extensive and diversified range of sideboards, cabinets, display cabinets and TV units devised to accommodate the most multifarious requirements. Featuring doors and drawers with assisted closing, some versions come with open compartments or glass doors, and with a glass or matching finish top.

Materiali e finiture

Struttura: Fashion wood, Roveri laccati opachi, Laccati opachi e lucidi, Laccati micalizzati.

Struttura interna: Decor Tortora.

Materials and finishes

Structure: Fashion wood, Matt lacquered oak, Matt or high gloss lacquer, micalised lacquer.

Internal structure: Tortora Decor.

Base TV / TV base

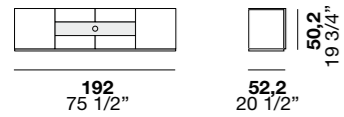

Credenze / Sideboards

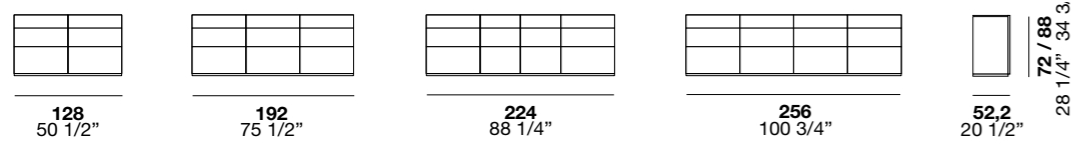

Credenze ante vetro / Sideboards with glass doors

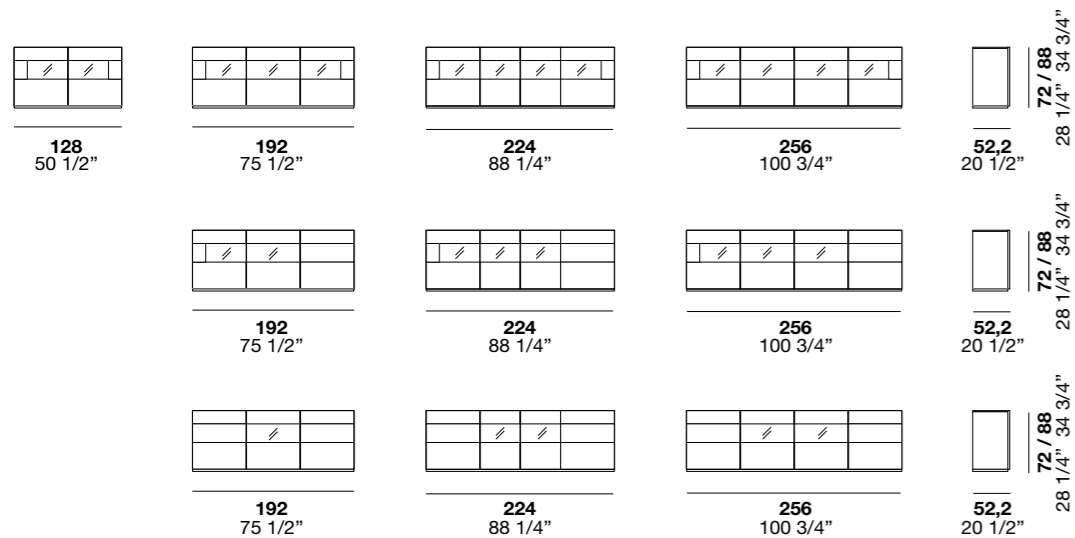

Credenze vani a giorno / Sideboards with open compartments

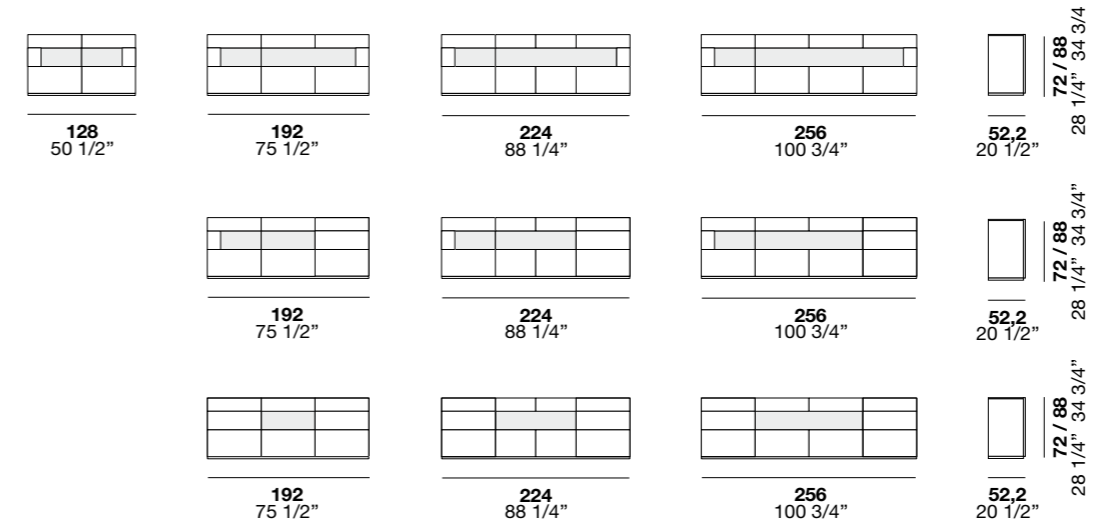

Madie / Cabinets

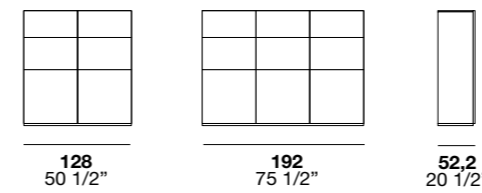

Madie ante vetro / Cabinets with glass doors

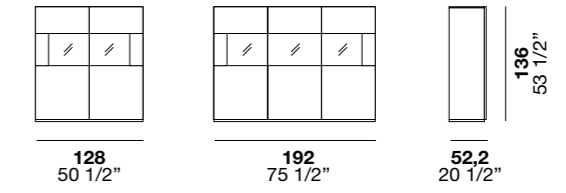

Madie vani a giorno / Cabinets with open compartments

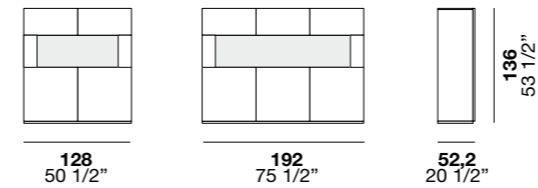

Vetrina / Display cabinet

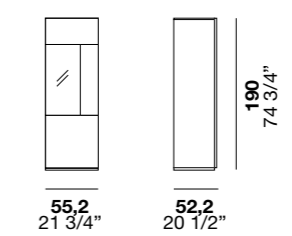

Da-Do^{giorno}

In Da-Do^{giorno} la scelta di linee geometriche corrisponde al desiderio di offrire molteplici combinazioni: con appoggio a terra oppure pensile, in diversi abbinamenti cromatici fra l'esterno e l'interno, per offrire risultati estetici ogni volta unici per ogni stile d'interno.

With the Da-Do^{giorno}, the choice of geometric lines is rooted in a desire to offer multiple combinations: floor-standing or wall-mounted, with various colourways for the interior and exterior, offering unique aesthetic results for any furnishing style.

design R&D Alf DaFrè

Da-Do^{giorno} credenza / sideboard
Struttura esterna Laccato Piombo lucido,
top, gola e vano a giorno Laccato Piombo
opaco / External structure in high gloss
Piombo lacquer, Top, groove and open
compartment in matt Piombo lacquer
L/W179,1 P/D47 H52,7





Da-Do^{giorno} porta TV / TV base
Nobilitato Metal smoke /
Metal smoke surfaced
L/W234,8 P/D47 H56

Kobe tavolino /occasional table
Struttura laccato opaco Moka shine, piano
Laminam Fokos Sale / Structure in matte
Moka shine lacquer and top in Laminam
Fokos Sale
L/W120 P/D70 H33



Da-Do^{giorno} credenza / sideboard
Struttura esterna nobilitato Rasato, top,
gola e vano a giorno nobilitato Olmo scuro /
External structure in Stucco look surfaced,
Top, groove and open compartment in
Scuro elm surfaced
L/W120,7 P/D47 H107

Corium sedia / chair
Cuio 1031 / 1031 leather
L/W50,5 P/D55 H80

Da-Do^{giorno}

Credenze e madie / Sideboards and cabinets



Da-Do^{giorno} madia / cabinet
 Fashion wood rovere Fossile e interno
 laccato opaco Nude / Fashion wood Fossile
 oak and Nude matte lacquer interior
 L/W120,7 P/D47 H137,7

Malmo tavolino/ occasional table
 Laccato opaco Nude/ nude matte lacquer
 L/W42 P/D42 H50

Nobu pouf
 Tessuto Made F 21 piano Moka shine /
 Made F 21 fabric and Moka shine top
 L/W42,6 P/D38,6 H38



Da-Do^{giorno} madia / cabinet
Fashion wood rovere Fossile e interno
laccato opaco Nude / Fashion wood Fossile
oak and Nude matte lacquer interior
L/W120,7 P/D47 H137,7





Da-do credenza / sideboard
 Struttura esterna laccato opaco Platino,
 top e gola laccato opaco Modica /
 External structure in Platino matt lacquer,

Top and groove in Modica matt lacquer
 L/W234,8 P/D47 H52,7

DA-DO giorno

design R&D Alf DaFrè

Da-Do ^{giorno} è un programma giorno composto da Porta TV, Credenze e Madie posizionabili a terra con piedini o piedi in metallo o appesi a parete. Da-Do giorno è altamente personalizzabile grazie all'abbinamento di due finiture, una per l'esterno e una per top e gola che funge da presa per l'apertura. Disponibile inoltre vano a giorno con finitura a contrasto.

Materiali e finiture

Struttura esterna: Nobilitati, Nobilitati roveri laccati opachi, Fashion wood, Roveri laccati opachi, Laccati opachi e lucidi, Laccati micallizzati.
 Top e gola: Nobilitati, Nobilitati roveri laccati opachi, Fashion wood, Roveri laccati opachi, Laccati opachi.
 Struttura interna: Nobilitato Piombo.

Da-Do ^{giorno} is a living room range which includes TV units, cabinets and sideboards, which can be free-standing with feet or metal legs, or wall-mounted. Da-Do giorno is highly customisable thanks to the two matching finishes: one for the exterior and one for the top and groove, which acts as a handle grip. An open-fronted compartment with a contrasting finish is also available.

Materials and finishes

External structure: Surfaced, matt lacquered oak surfaced, Fashion wood, Matt lacquered oak, Matt or high gloss lacquer, Micalised lacquer.
 Fronts: Surfaced, matt lacquered oak surfaced, Fashion wood, Matt lacquered oak, Matt lacquer.
 Internal structure: Piombo surfaced.

Porta TV sospeso / Hanging TV unit

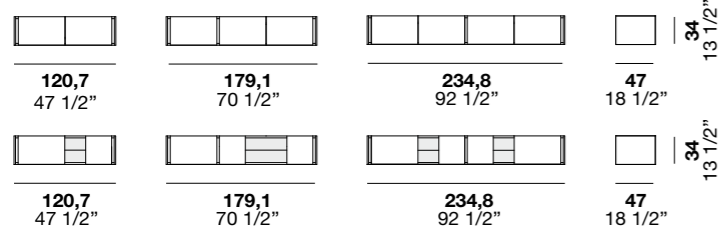

Porta TV con piedini / TV unit with feet

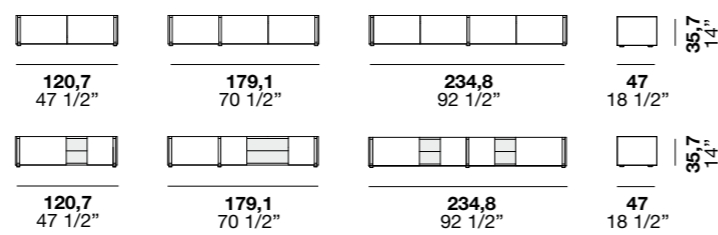

Porta TV con piedi in metallo / TV unit with metal feet

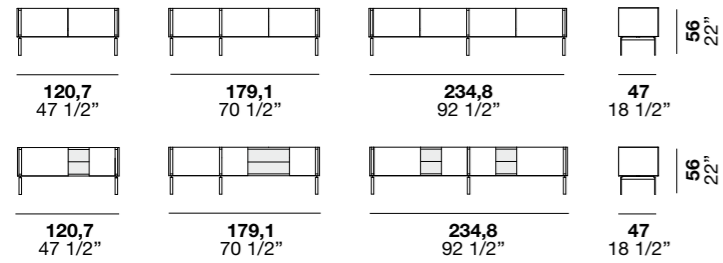

Credenze sospese / Hanging sideboard

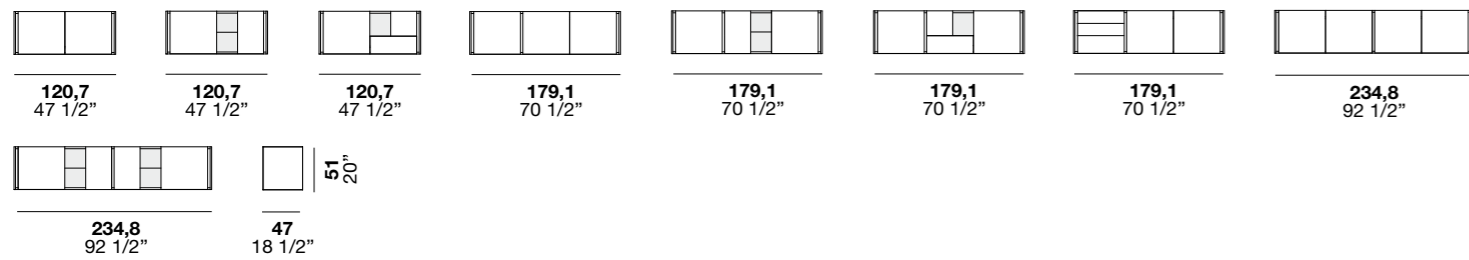

Credenze con piedini / Sideboard with feet

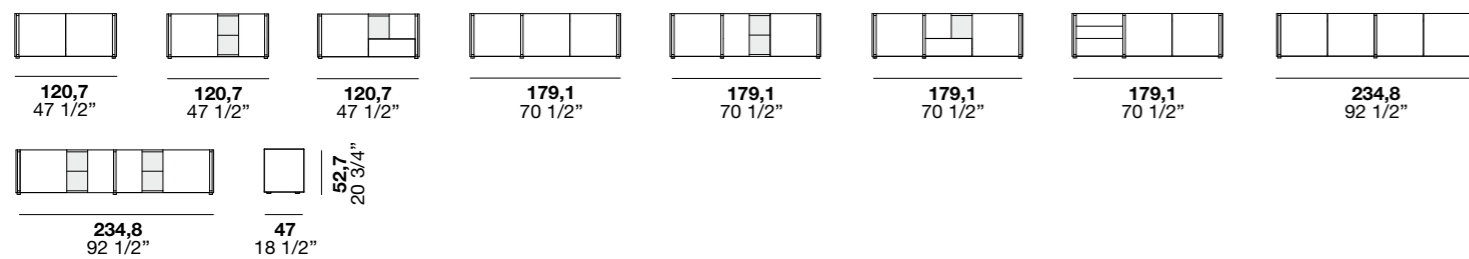

Credenze con piedi in metallo / Sideboard with metal feet

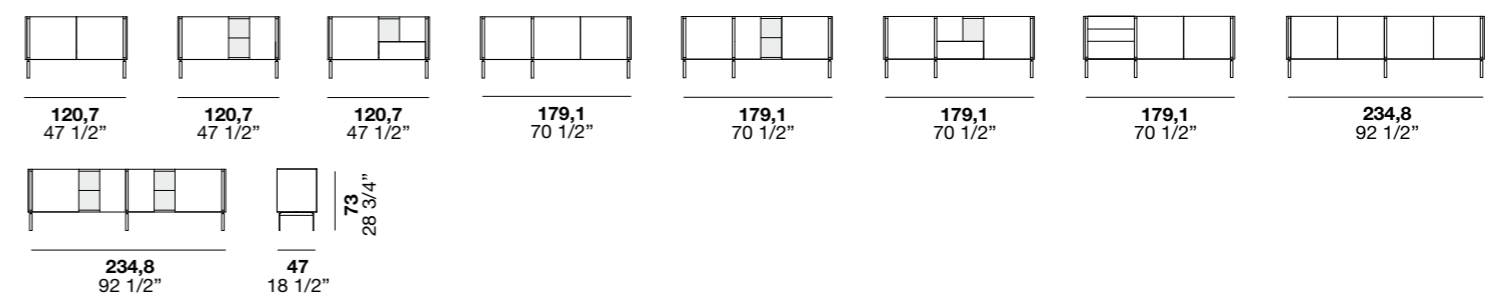

Credenze con piedini / Sideboard with feet

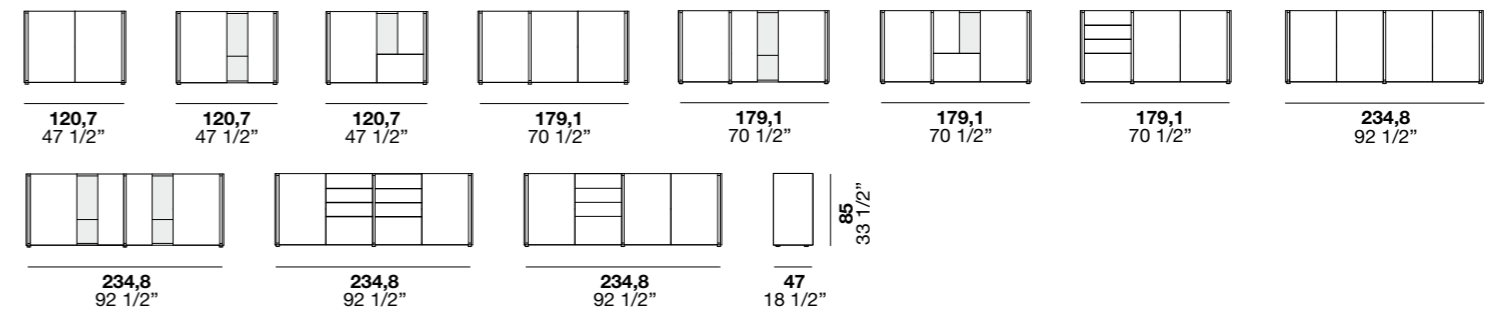

Credenze con piedi in metallo / Sideboard with metal feet

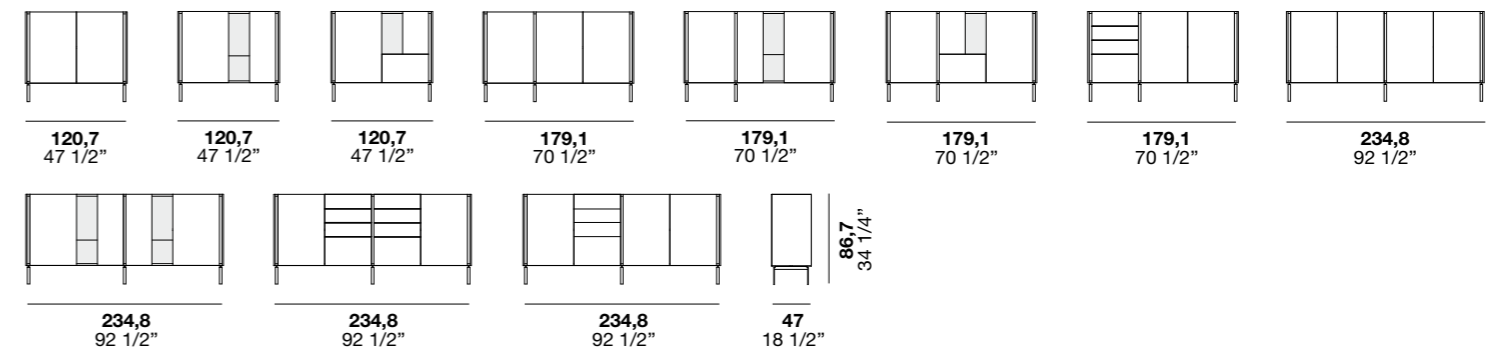

Madie con piedini / Cabinets with feet



^{IT} Tavoli come protagonisti di uno spazio fatto di emozioni, attorno ai quali ritrovare il piacere del calore domestico e i valori della cultura dell'abitare. Tradizioni che prendono forme contemporanee, materiali che parlano linguaggi senza tempo né confini, emozioni da assaporare e condividere.

^{EN} Tables as centrepieces in spaces infused with emotion, around which to enjoy the pleasure of domestic warmth and the values of homelife. Traditions take contemporary forms, materials speak timeless languages without boundaries, offering emotions to savour and share.

- 142 Esse
- 160 Pols
- 168 Gubia tavolo
- 176 Adamo
- 190 Jag
- 200 Fyra
- 212 Rigadin
- 222 Fusello
- 232 Cartesio



Esse

Emerge nello spazio con la forza scultorea della sua base, composta da due elementi curvi e simmetrici che sostengono il piano in legno, vetro o ceramica, in un gioco seducente di forme, ombre, riflessi e matericità.

Esse emerges from the space with the sculptural impact of its base unit, composed of two symmetrical curved elements supporting a wooden, glass or ceramic top, in a seductive interplay of shapes, shadows, reflections and textures.

design R&D Alf DaFrè





Esse tavolo / table
Nickel spazzolato e Fashion wood Rovere
Fossile / Brushed Nickel and Fashion wood
Fossile oak
L/W280 P/D120 H75,4

Tina sedia / chair
Tessuto Fenkè Unito 301 e gambe Fashion
wood Rovere fossile / Fenkè Unito 301 fabric
and Fashion wood Fossile oak legs
L/W60,8 P/D57,1 H81





Esse tavolo / table
 Top Fashion wood Rovere Fossile e
 basamento Spazzolato Nickel / Fashion
 wood Fossile Oak top and Brushed Nickel
 basement
 L/W280 P/D120 H75,4

Karol wood sedia / chair
 Gambe Noce naturale e tessuto Nodone
 A1304 / Natural walnut legs and Nodone
 A1304 fabric
 L/W50 P/D62 H80

Gioberg credenza / sideboard
 Laccato lucido Anfora e top laccato
 Azalea/ High gloss lacquer Anfora and
 Azalea lacquer top
 L/W200,2 P/D51,8 H78,3





Esse tavolo / table
Top vetro trasparente grigio e basamento
Nickel spazzolato/ Transparent gray glass
top and brushed Nickel basement
L/W280 P/D120 H74,1

Raku sedia / chair
Tessuto Nodone A1304 / Nodone
A1304 fabric
L/W55,5 P/D55 H80

Dama credenza / sideboard
Noce naturale e basamento Nickel / Natural
walnut and Nickel basement
L/W207,8 P/D52,2 H78





ESSE

design R&D Alf DaFrè

Un tavolo essenziale eppure espressivo. La base è costituita da due elementi simmetrici curvi in poliuretano ad alta densità che sostengono il piano in vetro, Fashion Wood o ceramica.

A simple yet expressive table. The base is made up of two symmetrical curved elements made of high-density polyurethane which support the glass, Fashion Wood or ceramic top.

Materiali e finiture

Basamento: Nickel spazzolato, Piombo spazzolato.

Piano: Vetro trasparente, Vetro trasparente grigio, Rovere laccato opaco, Fashion wood, Ceramiche.

Materials and finishes

Base: Brushed Nickel, brushed Piombo.

Top: Transparent glass, Grigio transparent glass, matt lacquer oak, Fashion Wood, Ceramic.

Piano legno (H75,4 cm) o ceramica (H74,5 cm) / Wood (H29 3/4") or ceramic (H29 1/4") top

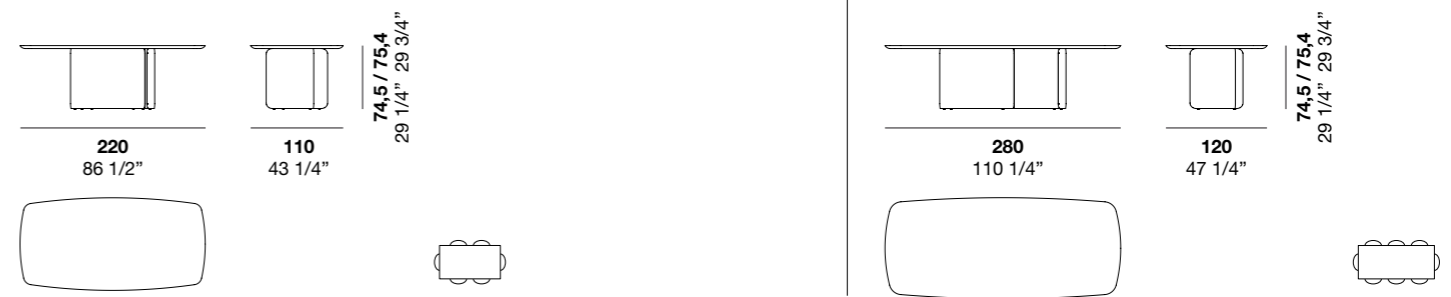

Piano vetro / Glass top

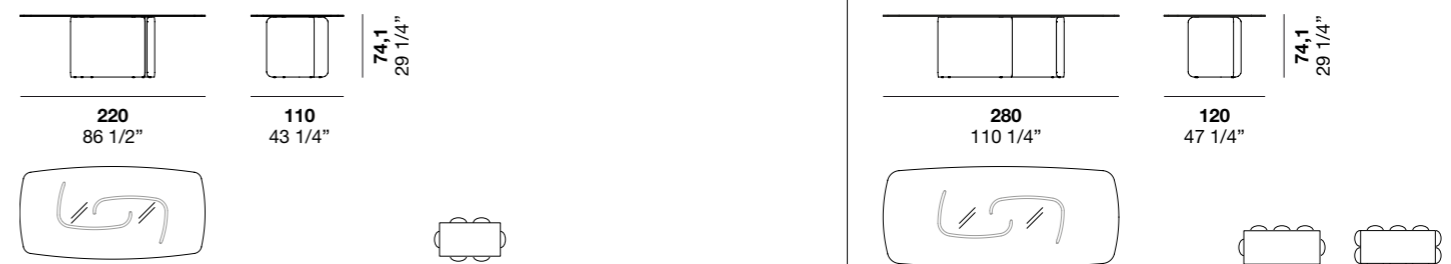

Ceramiche per piano / Top ceramics

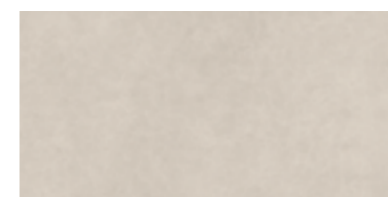

Laminam Fokos Sale

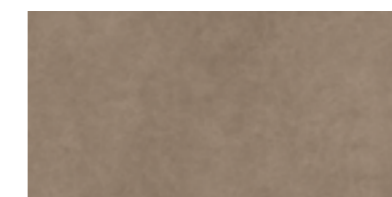

Laminam Fokos Terra

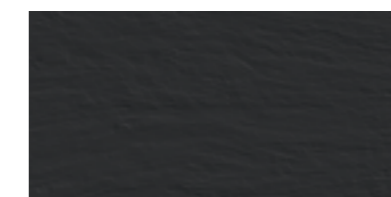

Laminam Ardesia a Spacco



Laminam bianco Statuario Venato Lucidato



Laminam Sahara Noir Extra Lucidato



Neolith Himalaya Crystal Ultrasoft



Neolith Amazonico Polished

Pols

Rigoroso ed espressivo, il tavolo Pols ha un'essenzialità contemporanea e una dimensione materica e artigianale che guarda alla tradizione. La sua superficie in vetro ricotto ambra o bronzo, delicatamente sfumata, lascia intravedere la raffinata semplicità della struttura e la combinazione tra vetro e legno massello.

Austere and expressive, the Pols table is contemporary in its simplicity and has a textured, artisanal quality that looks back to tradition. The delicately shaded Ambra or Bronzo annealed glass surface offers a glimpse of the refined simplicity of the frame and the harmonious combination of glass and solid wood.

design Gordon Guillaumier







Pols tavolo / table
 Struttura Fashion wood rovere Biscotto,
 piano vetro ricotto Ambra / Structure in
 Fashion wood Biscotto oak, top in Ambra
 annealed glass
 L/W235 P/D102 H73,4

Stiks sedia / chair
 Struttura Fashion wood rovere Biscotto,
 seduta e schienale tessuto Taiga 01 colore
 32/1 / Structure in Fashion wood Biscotto
 oak, seat and back in Taiga 01 fabric colour
 31/1
 L/W59,4 P/D50,6 H72,9





POLS

design Gordon Guillaumier

design depositato

La composizione è caratterizzata dal particolare "incastro" tra le gambe tubolari e gli elementi orizzontali della struttura che sporgono leggermente dalla geometria del tavolo. Il piano è in vetro ricotto Ambra o Bronzo. Struttura in legno massello disponibile in tutte le finiture di Fashion wood.

The composition stands out for the unusual join between the tubular legs and the horizontal elements of the frame, which extend slightly beyond the table's geometric form. The top is made of Ambra or Bronzo annealed glass. The solid wood frame is available in all Fashion Wood finishes.

Materiali e finiture

Struttura: Fashion wood.

Piano: Vetro ricotto Bronzo, Vetro ricotto Ambra.

Materials and finishes

Structure: Fashion wood.

Top: Bronzo annealed glass, Ambra annealed glass.

Tavolo / Table

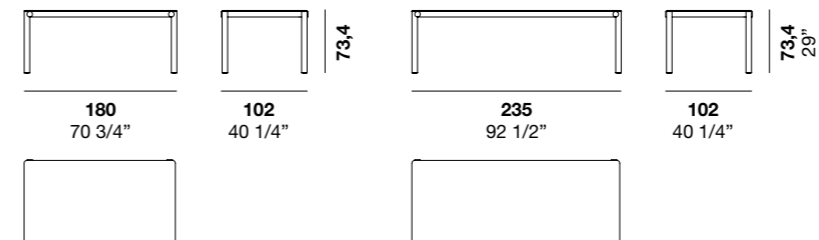

Top vetro ricotto / Annealed glass top



Bronzo



Ambra

Gubia tavolo

Ha uno spirito contemporaneo e una singolare affinità con la tradizione artigianale della lavorazione del legno. Il suo nome si ispira al classico scalpello a sezione curva, utilizzato in falegnameria per scavare artigianalmente solchi arrotondati nel legno. La lavorazione tattile dà un aspetto raffinato: la sottrazione di materia come elemento di decoro.

The Gubia table exudes a contemporary spirit while embodying a unique connection to the artisanal tradition of woodworking. Its name is inspired by the classic gouge chisel, traditionally used in carpentry to carve rounded grooves into wood. The tactile craftsmanship imbues a refined aesthetic: material subtraction becomes a decorative element.

design Gordon Guillaumier





Gubia tavolo / table
Fashion wood rovere Terra / Fashion
wood Terra oak
L/W240 P/D100 H74

Raku sedia / chair
Pelle Lord 9130 / Leather Lord 9130
L/W55,5 P/D55 H80





GUBIA

design Gordon Guillaumier

design depositato

La struttura – disponibile in Fashion wood Rovere terra – ha una superficie tattile che rimanda alla lavorazione del legno con lo scalpello a sezione curva.

The structure, available in Terra oak Fashion Wood, features a tactile surface reminiscent of woodworking with a gouge chisel.

Materiali e finiture
Struttura e frontali: Fashion wood Terra.

Materials and finishes
Structure and top: Terra Fashion Wood.

Tavolo / Table

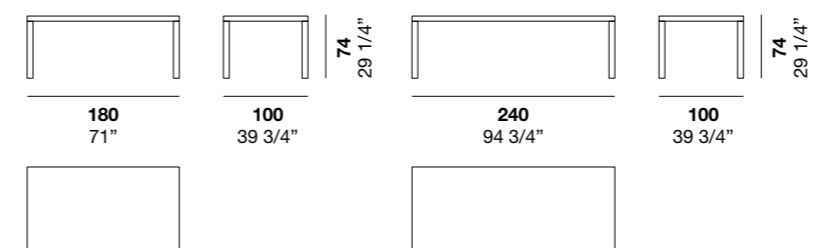

Gubia

Tavoli / Tables

Adamo

Adamo è stile e funzionalità allo stato puro: le sue linee arrotondate, con snelle gambe affusolate che si inseriscono armoniosamente nello spessore del piano, definiscono la sua leggerezza estetica e funzionale al tempo stesso.

Adamo is style and functionality in its purest form: rounded lines, with slender tapered legs that run harmoniously into the volume of the top, define its aesthetic and functional lightness.

design Bruna Vaccher





Adamo tavolo / table
Fashion wood Rovere Naturale e top
ceramica neolith Himalaya Crystal ultrasoft
/ Fashion wood Naturale oak and neolith

Himalaya Crystal ultrasoft ceramic top
L/W200 P/D100 H75,6

Karol sedia / chair
Tessuto Made F19/ Made F19 Fabric
L/W50 P/D62 H80





Adamo tavolo / table
Fashion wood Rovere Carbone / Fashion
wood Carbone oak
L/W200 P/D100 H76,4

Musa credenza / sideboard
Laccato opaco Cuoio naturale e basamento
Moka shine / Cuoio naturale matte lacquer
and Moka shine basement
L/W220 P/D52,7 H75

Corium sedia / chair
Cuoio naturale / Natural leather
L/W50,5 P/D55 H80/93





Adamo tavolo / table
Fashion wood Ghiro/ Fashion wood Ghiro
L/W200 P/D100 H76,4

Karol sedia / chair
Tessuto Nodone A1311/ Nodone A1311 fabric
L/W50 P/D62 H80

Disco specchiera / mirror
Cornice Moka shine / Moka shine frame
L/W99,5 P/D4 H99,5
L/W49,7 P/D4 H49,7



ADAMO

design Bruna Vaccher

Funzionale, leggero e contemporaneo: Adamo è il protagonista dello spazio living contemporaneo. Particolare per proporzioni equilibrate e per le linee arrotondate che definiscono tutti gli elementi compositivi. Le gambe affusolate si inseriscono nella cornice sottopiano dal profilo curvilineo. Il piano sottile è caratterizzato da angoli arrotondati con un effetto equilibrio e di armonia classica. La struttura è realizzata in fashion wood. Il piano è proposto in Fashion wood / ceramiche.

Light, functional and contemporary: Adamo is the protagonist of the contemporary living room. It is unusual in its balanced proportions and the rounded lines that define each element. The tapered legs are inserted into the frame under the top of the curvilinear profile. The slim top has rounded corners to give an effect of balance and classic harmony. The structure is made of Fashion Wood. The top comes in Fashion Wood or ceramic versions.

Materiali e finiture
Struttura: Fashion wood.
Piano: Fashion wood, Ceramiche.

Materials and finishes
Structure: Fashion wood.
Top: Fashion wood, Ceramic.

Piano legno / Wooden top

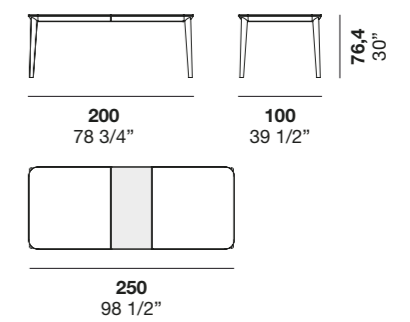
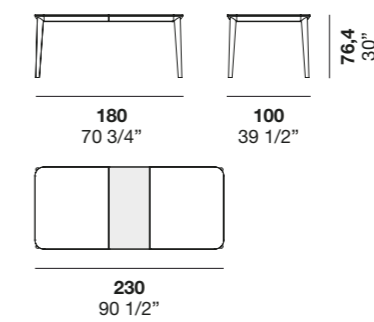
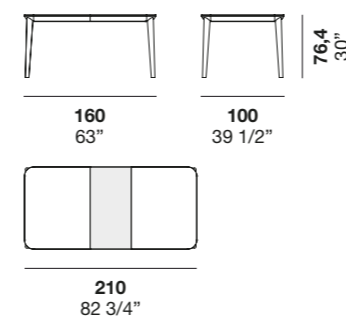

Piano ceramica / Ceramic top

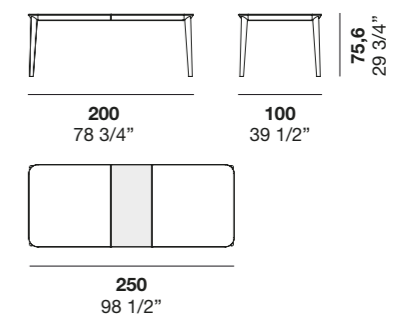
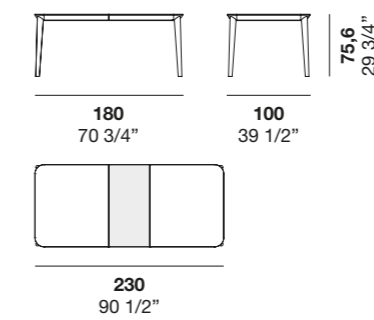
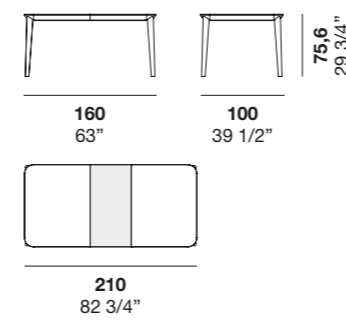

Ceramiche per piano / Top ceramics

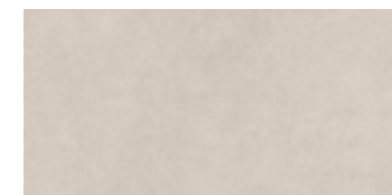

Laminam Fokos Sale

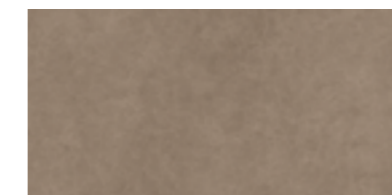

Laminam Fokos Terra

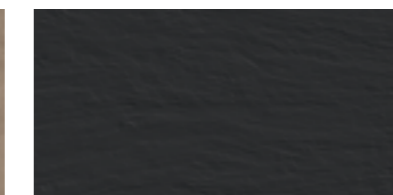

Laminam Ardesia a Spacco



Laminam bianco Statuario Venato Lucidato



Laminam Sahara Noir Extra Lucidato



Neolith Himalaya Crystal Ultrasoft



Neolith Amazonico Polished

Jag

Jag è un tavolo che unisce tradizione e modernità, attraverso l'abbinamento dei due materiali che meglio rappresentano questi concetti: il legno e il metallo. Viene proposto in versione allungabile, per soddisfare ogni esigenza d'arredo e di convivio.

Jag is a table that marries tradition and modernity through the pairing of the two materials that best represent these concepts: wood and metal. It is available in extensible version, to meet any interior-design or hosting needs.

design Haften studio





Jag tavolo / table
Piano Fashion wood Rovere Carbone e
struttura Moka shine / Fashion wood
Carbone oak top and Moka shine structure
L/W181 P/D95 H74,7

Diko credenza / sideboard
Fashion wood Rovere Carbone e basamento
Moka shine / Fashion wood Carbone oak
and Moka shine basement
L/W194,8 P/D45,4 H67

Corium sedia / chair
Cuio 1031/ 1031 leather
L/W50,5 P/D55 H80



Jag tavolo / table
Top ceramica neolith Himalaya Crystal ultrasoft, struttura Nickel / Neolith Crystal ultrasoft ceramic top, nickel structure
L/W181 P/D95 H74,8

Corium sedia / chair
Cuoio naturale / Natural leather
L/W50,5 P/D55 H80

Dama credenza / sideboard
Noce naturale, Top ceramica neolith Himalaya Crystal ultrasoft e basamento Nickel / Natural walnut, Neolith Crystal ultrasoft ceramic top and Nickel basement
L/W207,8 P/D52,2 H78





JAG

design Haften studio

Jag è un tavolo con struttura in metallo verniciato e piano in legno o ceramica, disponibile in versione allungabile.

The Jag table has a painted metal structure and a wooden or ceramic table top, and it is available in the fixed or extending version.

Materiali e finiture

Piano: Nobilitati, Nobilitati roveri laccati opachi, Fashion wood, Roveri laccati opachi, Laccati opachi, Laccati micalizzati, Noce, Ceramiche.

Struttura: Verniciato bianco, Verniciato Moka shine, Verniciato Nickel.

Materials and finishes

Top: Surfaced, matt lacquered oak surfaced, Fashion wood, Matt lacquered oak, Matt lacquer, Micalised lacquer, Walnut, Ceramics.

Structure: Bianco painted, Moka shine painted, Nickel painted.

Tavolo allungabile / Extendable table

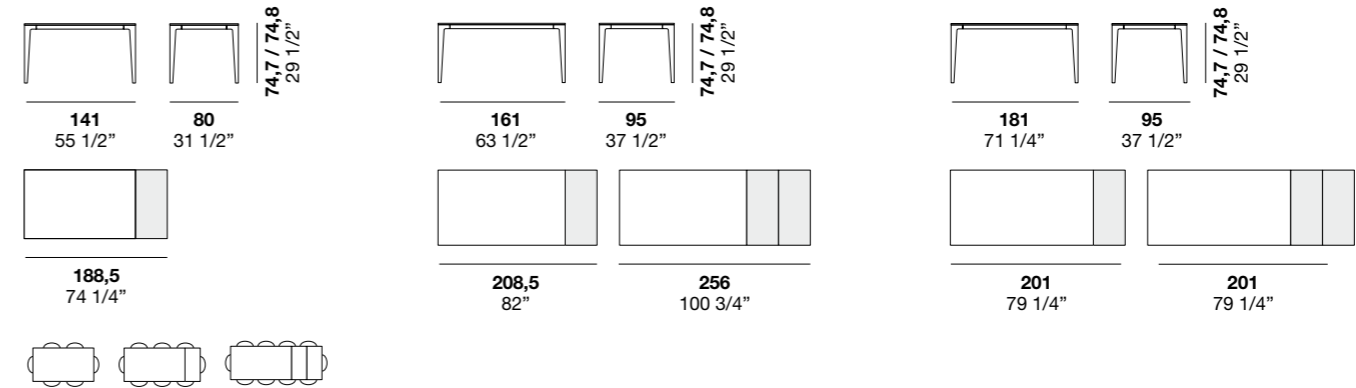

Ceramiche per piano / Top ceramics

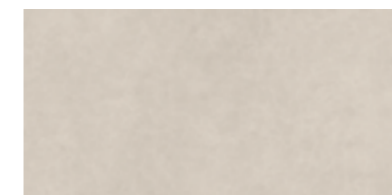

Laminam Fokos Sale

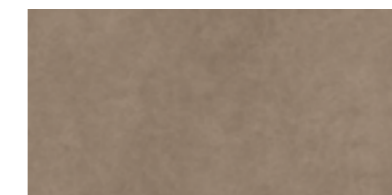

Laminam Fokos Terra

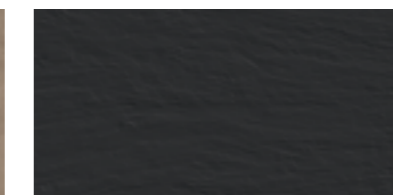

Laminam Ardesia a Spacco



Laminam bianco Statuario Venato Lucidato



Laminam Sahara Noir Extra Lucidato



Neolith Himalaya Crystal Ultrasoft



Neolith Amazonico Polished

Fyra

L'antica arte dell'ebanisteria italiana, rivive in forma contemporanea con Fyra: un tavolo caratterizzato da una particolare geometria, con un piano diviso in quadranti che creano affascinanti incontri di venature, frutto di una profonda esperienza e passione artigianale.

The ancient art of Italian cabinet-making is revived in a contemporary form with Fyra: a table with a unique shape, featuring a top divided into quadrants that create captivating effects with the grain, thanks to true expertise and artisan passion.

design R&D Alf DaFrè





Fyra tavolo / table
Fashion wood Rovere Naturale e Moka shine / Fashion wood Naturale oak and Moka shine
L/W278,5 P/D104,5 H75,4

Corium sedia / chair
Tessuto Fado 26 / Fado 26 fabric
L/W50,5 P/D55 H80



Antis sistema giorno / living system
Struttura Moka Shine, Mensole Fashion wood rovere Ghiro, Contenitori Fashion wood rovere Ghiro e maniglia T16 Moka shine / Moka Shine structure, Shelves in

Ghiro oak Fashion wood, Box units in Ghiro oak Fashion wood and T16 handle in Moka shine
L498 P41,6 H300
→ Cat. Day collection / Antis

Fyra tavolo / table
Fashion wood Rovere Naturale e Moka shine / Fashion wood Naturale oak and Moka shine
L/W278,5 P/D104,5 H75,4

Corium sedia / chair
Tessuto Fado 26 / Fado 26 fabric
L/W50,5 P/D55 H80



Fyra tavolo / table
Noce Naturale e Nickel / Natural walnut
and Nickel
L/W180 P/D95 H75,4

Karol wood sedia / chair
Gambe noce naturale e tessuto Nodone
A1304 / Natural walnut legs and Nodone
A1304 fabric
L/W50 P/D62 H80

Diko credenza / sideboard
Fashion wood Rovere Carbone e
basamento Nickel / Fashion wood
Carbone oak and Nickel basement
L/W194,8 P/D45,4 H67





FYRA

design R&D Alf DaFrè

Il tavolo è caratterizzato da geometrie sofisticate e da "stacchi" tra gli elementi che rendono la composizione molto espressiva. Il piano, definito da una linea mista a metà tra retta e curvilinea, è diviso in 4 quadranti che creano con le venature del legno un motivo tipico della tradizione ebanista. Una piastra di ferro collega e contemporaneamente separa visivamente il piano dalle 4 gambe a sezione conica irregolare, più rotonda alla base e più ovalizzata all'estremità superiore. Fyra è proposto in tutte le finiture di Fashion wood, Noce e Roveri laccati.

Materiali e finiture

Gambe e piano: Fashion wood, Roveri laccati opachi, Noce.
Staffe di collegamento in metallo: Verniciato Moka shine, Verniciato Nickel.

The table features sophisticated geometry and intervals between the elements that make the composition very expressive. The top, defined by a line that is a mixture of half straight and half curvilinear, is divided into 4 quadrants which create a typical design from traditional carpentry with the wood grain. An iron plate connects and, at the same time, visually separates the top from the 4 legs which have an irregular conical cross-section, rounder at the base and more oval at the top end. Fyra comes in all the Fashion Wood, Walnut and matt lacquer oak finishes.

Materials and finishes

Legs and top: Fashion wood, Matt lacquered oak, Walnut.
Metal brackets: Painted Moka shine, painted Nickel.

Tavolo fisso / Fixed table

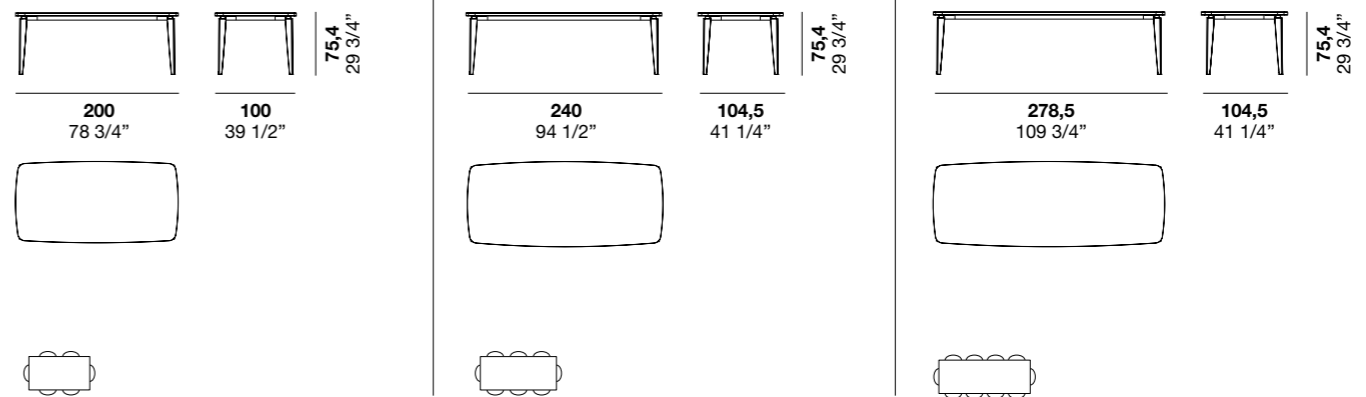

Tavolo allungabile / Extendable table

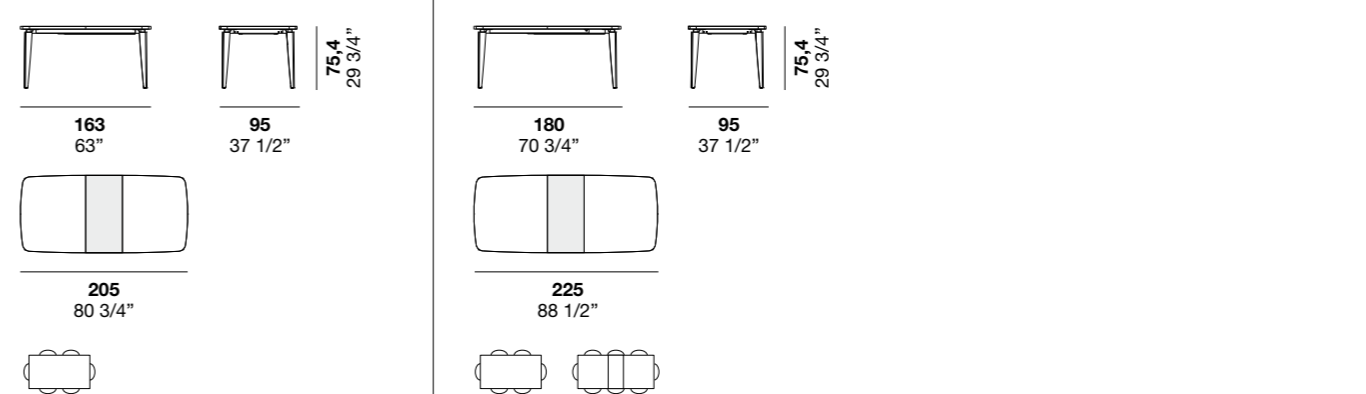

Rigadin

Il tavolo Rigadin parla il linguaggio della natura ed esprime un prestigio autentico, oltre il tempo e le mode. La base in legno, con il suo ritmico susseguirsi di linee verticali, si unisce a un piano in metallo o pietra, in un perfetto equilibrio di forme e sensazioni materiche che trovano massima esaltazione nell'abbinamento con la credenza della collezione.

The Rigadin table speaks the language of nature and expresses its authentic prestige, beyond time and trends. The wooden base, with its rhythmic use of vertical lines, is combined with a metal or stone top, achieving a perfect balance of forms and textural effects, which reach their zenith when paired with the sideboard in the collection.

design Gordon Guillaumier





Rigadin tavolo / table
Struttura Frassino tinto Noce, top metallo
/ Structure Walnut painted Frassino,
Metal top
L/W250 P/D105 H74

Rigadin credenza / sideboard
Struttura Frassino tinto Noce, top metallo
/ Structure Walnut painted Frassino,
Metal top
L/W192 P/D47,6 H72,7

Karol sedia / chair
Pelle Alfa 4190 / 4190 Alfa leather
L/W50 P/D62 H80



Rigadin tavolo / table
Struttura Frassino tinto Noce, top metallo
/ Structure Walnut painted Frassino,
Metal top
L/W250 P/D105 H74



Rigadin tavolo / table
Struttura Frassino tinto Noce, top metallo
/ Structure Walnut painted Frassino,
Metal top
L/W250 P/D105 H74

Corium sedia / chair
Cuoio 1031 / 1031 leather
L/W50 P/D62 H80



Rigadin tavolo / table
 Piano Pietra Camouflage e basamento
 Noce / Camouflage stone top and
 Walnut basement
 L/W250 P/D105 H75,7

Raku sedia/chair
 Tessuto Nodone 1304/ Nodone fabric 1304
 L/W55,5 P/D55 H80

RIGADIN

design Gordon Guillaumier

Il legno massello è l'essenza di Rigadin. Una collezione preziosa e vera, dove la bellezza è forma ma anche sostanza. Pregio ed essenzialità sono plasmati in modo personale, connessi da ispirazione e artigianalità. Disponibile in versione con top metallo o marmo / pietra.

Materiali e finiture
 Piano: Marmo, Pietra, Metallo verniciato elettrocol raggrinzante.
 Basamento: Frassino tinta noce.

Solid wood is the essence of Rigadin. A fine, authentic collection, where beauty is substance as well as form. Quality and simplicity are moulded to measure, at one in their inspiration and craftsmanship. Available with metal or marble / stone top.

Materials and finishes
 Top: textured "Elettrocol" painted metal, marble or stone.
 Base: Walnut tinted ash.

Piano in metallo / Metal top

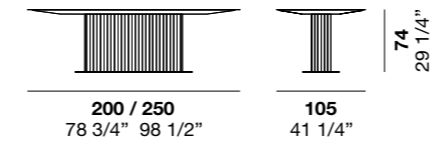

Top marbles-stones

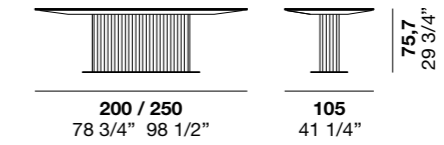

Marmi-Pietre per piani / Top marbles-stones



Emperador Lucido



Emperador Spazzolato



Pietra Lavica Spazzolata



Infinity



Camouflage

Fusello

Fusello prende il nome dal volume delle gambe, ispirate all'antico attrezzo in legno che veniva utilizzato per la lavorazione del pizzo. Una citazione formale che esprime un'idea di morbidezza, grazia e organicità, ripresa anche dal perimetro arrotondato del piano in legno, marmo o vetro.

Fusello takes its name from the design of its legs, inspired by the traditional wooden tool used for lacework. This formal reference expresses an idea of softness, grace and organicity, also featured in the rounded edge of the wooden, marble or glass top.

design Molteni Baron associati

Fusello tavolo / table
Struttura e piano Fashion wood Rovere
Carbone /Structure and top in Carbone
oak Fashion wood
L/W280 P/D105 H75,2

Corium sedia / chair
Cuio 1031 / 1031 leather
L/W50,5 P/D55 H80





Fusello tavolo / table
Struttura Fashion wood Rovere Carbone,
piano Marmo Nero Marquinia lucido /
Structure in Carbone oak Fashion wood,
top in gloss Nero Marquinia marble
L/W280 P/D105 H76



Fusello tavolo / table
Struttura Rovere colore opaco Amaranto,
piano vetro trasparente / Structure
in matt Amaranto lacquer oak, top in
transparent glass
L/W280 P/D105 H74

Shift sedia / chair
Struttura Fashion wood Rovere Carbone,
seduta e schienale tessuto Doble 28 /
Structure in Carbone oak Fashion wood,
seat and back in Doble 28 fabric
L/W49 P/D54,7 H76,8



Fusello tavolo / table
 Struttura Fashion wood Rovere Carbone,
 piano Vetro trasparente grigio /
 Structure in Carbone oak Fashion wood,
 top in Grey transparent glass
 L/W280 P/D105 H74

Shift sedia / chair
 Cuoio 1031 / 1031 leather
 L/W50,5 P/D55 H80





Shift sedia / chair
Struttura Fashion wood Rovere Carbone, seduta e schienale tessuto Doble 28 / Structure in Carbone oak Fashion wood, seat and back in Doble 28 fabric
L/W49 P/D54,7 H76,8

Fusello tavolo / table
Struttura Rovere colore opaco Amaranto e piano Fashion wood Rovere Carbone / Structure in matt Amaranto lacquered oak, top in Fashion wood Carbone oak
L/W280 P/D105 H76

FUSELLO

design Molteni Baron associati

Fusello è un tavolo che nasce dalla nostra tradizione. Il basamento è realizzato con gambe dalla forma del Fusello, il rocchetto con avvolto il filo per la lavorazione del pizzo di Cantù. La morbidezza, caratteristica insita nel tavolo, è data non solo dalle gambe, ma anche dalle diverse forme organiche che può avere il piano e dall'utilizzo del legno, materiale che offre la migliore espressione di plasticità.

Materiali e finiture

Struttura: Fashion wood, Roveri laccati opachi.
Piano: Fashion wood, Roveri laccati opachi, Vetro trasparente, Vetro trasparente grigio, Marmi, Pietre.

Fusello is a table born out of tradition. The base is made up of spindle legs, evoking the spool for winding thread used to make Cantu lace. The table's innately soft look is given not only by these legs but also by the different physical forms the top can take on, and the use of wood, a material offering the very best sculptural qualities.

Materials and finishes

Structure: Fashion wood, Matt lacqued oak.
Top: Fashion wood, Matt lacqued oak, Transparent glass, Grigio transparent glass, Marbles, Stones.

Piano legno / Wooden top

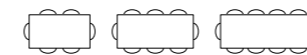
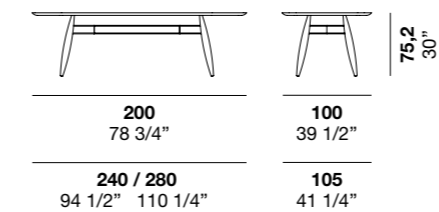

Piano marmo / Marble top

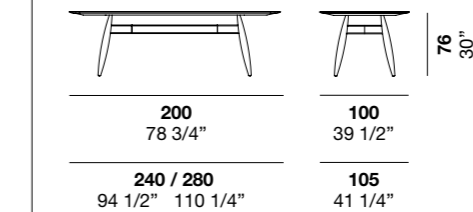

Piano vetro / Glass top

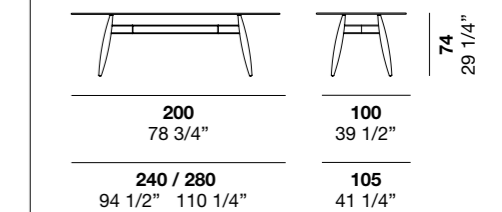

Marmi-Pietre per top / Top marbles-stones



Nero Marquina Lucido



Nero Marquina Leather



Atlantic White



Infinity



Rosso Levanto



Camouflage

Cartesio

Cartesio è caratterizzato dal razionalismo della struttura in legno, realizzata con elementi squadrati che compongono un'originale geometria. Il piano di forte spessore contribuisce a renderlo un protagonista dell'ambiente, mentre le allunghe si prestano a soddisfare ogni esigenza d'uso.

Cartesio is characterised by its rationalised wooden structure, created with square elements that compose an original form. The thick top helps to make this a centrepiece, while extensions mean that any usage requirement can be met.

design Haften studio





Cartesio tavolo / table
Fashion wood rovere Carbone /
Carbone oak Fashion wood
L/W220 P/D100 H74

Corium sedia / chair
Cuoio naturale / Natural leather
L/W50,5 P/D55 H80



CARTESIO

design Haften Studio

Cartesio è un tavolo con struttura in legno, rettangolare e allungabile. Cartesio si distingue per il piano e le allunghe di forte spessore e per la particolare conformazione del basamento in cui le gambe inclinate si collegano nella parte inferiore creando una "struttura chiusa".

Materiali e finiture
Struttura: Fashion wood, Rovere colori opachi.

The Cartesio table has a wooden structure, and it is either square or rectangular. Cartesio 2.0 stands out for the extra thick table top and extensions and for the particular shape of the base, with tilted legs that join at the bottom to form a "closed structure".

Materials and finishes
Structure: Fashion wood, Oak matt colours.

Tavolo allungabile / Extendable table

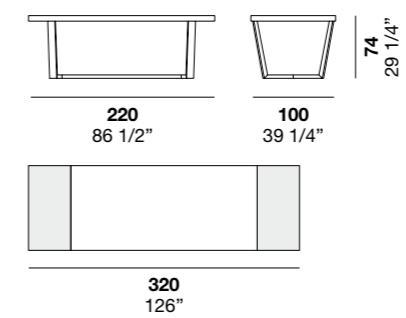
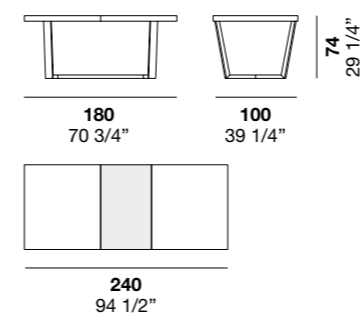

^{IT} Lo scrittoio come concetto di spazio e tempo personale. Uno spazio funzionale dove il design ricercato e i dettagli lo rendono un gioiello raffinato per le più diverse ambientazioni. Un tempo in cui dedicarsi a se stessi in armonia con l'ambiente e dove ritrovare concentrazione o piacere a seconda delle necessità.

^{EN} The desk as a concept of personal space and time. A functional space where refined design and details create a real gem for a whole range of different environments. Time dedicated to oneself, in harmony with the surroundings and a place for concentration or enjoyment, as needed.



Yukio

Yukio esprime una raffinata filosofia dell'abitare, in un elemento che offre diverse funzioni e si presta a molteplici ambientazioni. Quando è chiuso si può utilizzare come un elegante scrittoio, mentre sollevando il piano si accede a un capiente vano nascosto, attrezzato con un tappetino in cuoio e dotato di uno specchio rotondo adatto all'ambiente notte.

Yukio encapsulates a refined philosophy of living, in a multifunctional piece that suits a whole range of settings. When closed, it can be used as an elegant desk. Then, lifting the top provides access to a spacious hidden storage compartment, equipped with a leather liner and round mirror suitable for the bedroom.

design Gordon Guillaumier







Yukio scrittoio / desk
Noce naturale e struttura Nickel / Natural
walnut and Nickel structure
L/W142,3 P/D62,5 H79,8





Yukio scrittoio / desk
 Fashion wood Rovere Carbone e struttura
 Anfora opaco/ Fashion wood Carbone Oak
 and matt Anfora structure
 L/W142,3 P/D62,5 H79,8

Raku sedia / chair
 Tessto Nodone 1304 / Nodone fabric 1304
 L/W55,5 P/D55 H80





YUKIO

design Gordon Guillaumier

Registered design

Yukio è uno scrittoio con struttura in metallo e piano in legno apribile con vano porta oggetti.

Yukio is a desk with a metal frame and wooden top that opens with a storage compartment beneath.

Materiali e finiture
Struttura verniciato Moka Shine, Anfora o Nickel. Piano Noce naturale, Noce classico e Fashion wood.

Materials and finishes
Frame painted in Moka Shine, Anfora or Nickel. Natural and Classic walnut top and Fashion Wood.

Tappetino in Cuio 1004 di serie e specchio opzionale.

Leather 1004 mat as standard and optional mirror.

Yukio scrittoio / desk
Struttura verniciato Moka Shine,
Piano Fashion wood rovere Fossile /
Structure painted in Moka Shine /
Fashion Wood Fossile oak top
L/W142,3 P/D62,5 H79,8

Raku sedia / chair
Tessuto Nodone A1300 / Fabric Nodone A1300
L/W55,5 P/D55 H80

Scrittoio / Desks

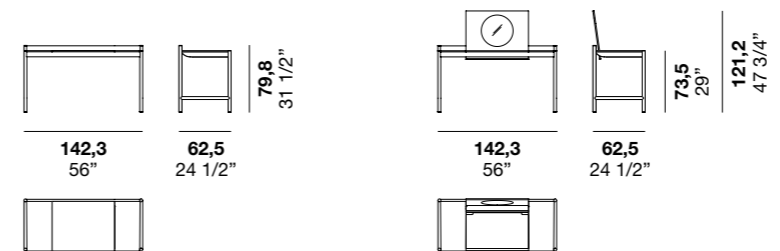

^{IT} Sedute che arricchiscono lo spazio introducendo bellezza, estetica e comfort, creando molteplici abbinamenti con gli altri elementi d'arredo. Interpretazioni originali di temi storici e di nuove tendenze del design, realizzazioni sartoriali che esprimono una raffinata e sapiente cura di ogni dettaglio.

^{EN} Seating that enhances the space, introducing beauty, design and comfort, creating plural combinations with other furniture. Original interpretations of historic themes and new design trends, sartorial creations that express a refined and skilful touch in every detail.

- 254 Stiks
- 260 Tina
- 266 Corium
- 274 Karol
- 280 Raku
- 286 Shift



Stiks

Pensata per affiancare il tavolo Pols e ispirata dalla stessa idea costruttiva. Il legno massello come una struttura che si combina perfettamente con l'imbottito in un'immagine leggera e confortevole grazie alla forma avvolgente dello schienale che abbraccia il volume della sedia. Particolare per rapporto tra i diversi elementi compositivi, si definisce in un naturale e confortevole equilibrio.

Designed to complement the Pols table, it is inspired by the same construction concept. Solid wood is used for the frame, pairing perfectly with the upholstery to create a light and comfortable look, thanks to the wrap-around shape of the back that embraces the chair's volume. The distinctive relationship between its various compositional elements offers a natural and soothing balance.

design Gordon Guillaumier





Stiks sedia / chair
Struttura Fashion wood rovere Biscotto,
seduta e schienale tessuto Taiga 01 colore
32/1 / Structure in Fashion wood Biscotto
oak, seat and back in Taiga 01 fabric colour
31/1
L/W59,4 P/D50,6 H72,9



STIKS

design Gordon Guillaumier

design depositato

Stiks è composta da un telaio in legno massello disponibile in tutte le finiture Fashion wood. La seduta e lo schienale sono imbottiti e rivestiti in tutti i tessuti e pelli della gamma Alf DaFrè.

Stiks features a solid wood frame available in all Fashion wood finishes. The seat and backrest are upholstered and covered in all fabrics and leathers from the Alf DaFrè range.

Materiali e finiture
Struttura: Fashion wood.
Rivestimento: Tessuti, Pelle.

Materials and finishes
Frame: Fashion Wood.
Upholstery: Fabric, leather.

Sedia / Chair

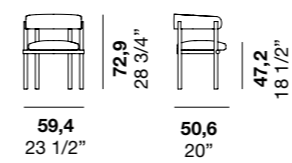

Tina

Morbida e seducente, Tina ha un design sagomato che genera un'irresistibile sensazione di comfort. Può indossare tanti diversi rivestimenti in pelle o tessuto, per intonarsi a ogni stile personale e situazione d'arredo.

Soft and seductive, Tina has a shaped design offering an irresistible sensation of comfort. Many different leather or fabric upholstery options are available, to match any personal style or interior project.

design R&D Alf DaFrè



Tina sedia / chair
Pelle 9340 e gambe Fashion wood Rovere
Naturale / 9340 leather and Fashion wood
Naturale oak legs
L/W60,8 P/D57 H81



Tina sedia / chair
Tessuto Made F16 e gambe Fashion wood
Rovere Fossile / Made F16 fabric and
Fashion wood Fossile oak legs
L/W60,8 P/D57 H81





Tina sedia / chair
 Tessuto Fenkè Unito 301 e gambe Fashion
 wood Roverè Fossile / Fenkè Unito 301
 fabric and Fashion wood Fossile oak legs
 L/W60,8 P/D57 H81

TINA

design R&D Alf DaFrè

Le linee morbide e confortevoli di Tina la rendono un'icona di eleganza e stile che si abbina ai tavoli della collezione Alf DaFrè. I rivestimenti in pelle o tessuto proposti in un'ampia gamma di finiture, consentono la massima personalizzazione per una sedia versatile per l'abitare contemporaneo.

Materiali e finiture
 Struttura: Fashion wood.
 Seduta e schienale: Tessuto, Pelle,
 Ecopelle.

Soft, comfortable lines make Tina an icon of elegance and style, to match the tables in the Alf DaFrè collection. Personalise the design in a wide range of leather or fabric upholstery finishes to create a versatile chair for contemporary living.

Materials and finishes
 Structure: Fashion wood.
 Seat and back: Fabric, Leather, Ecoleather.

Sedia / Chair

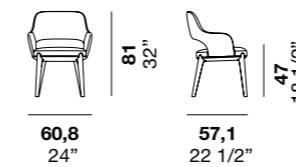

Corium

Completamente vestita in cuoio, tessuto o ecopelle, con una scelta fra moltissime finiture diverse, Corium abbina una grande eleganza a dimensioni compatte che la rendono ideale in qualsiasi spazio e situazione. Lo schienale, proposto in due altezze diverse, accoglie il corpo offrendo un confortevole supporto.

Dressed entirely in leather, fabric or fabric or ecoleather, with various finishes to choose from, Corium pairs great elegance with compact dimensions that make it ideal for any space or setting. The backrest, available in two different heights, accommodates the body with comfortable support.

design R&D Alf DaFrè



Corium sedia/chair
Cuoio 1031/ Leather 1031
L/W50,5 P/D55 H80



Corium sedia / chair
Cuoio naturale/ Natural leather
L/W50,5 P/D55 H93
L/W50,5 P/D55 H80



Corium sedia / chair
Tessuto Disco 26 / Disco 26 fabric
L/W50,5 P/D55 H80



Corium sedia / chair
Tessuto Fado 26 / Fado 26 fabric
L/W50,5 P/D55 H80

Fyra tavolo / table
Fashion wood rovere Naturale / Fashion
wood Naturale oak
L/W280 P/D104,5 H75,4

CORIUM

design R&D Alf DaFrè

Corium è una sedia dalla forma molto contenuta, disponibile con un rivestimento in cuoio, tessuto, pelle ed ecopelle e con uno schienale alto 93 cm o più contenuto, 80 cm.

Materiali e finiture
Rivestimento: Tessuto, Pelle, Ecopelle, Cuoio.

Corium is a chair with a very contained form, available with a leather, fabric, leather and eco-leather cover and with a 93 cm high or lower backrest, 80 cm.

Materials and finishes
Covering: Fabric, Leather, Ecoleather.

Schienale alto / High back

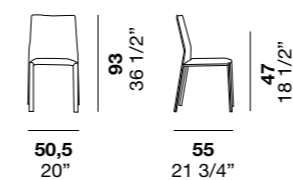

Schienale basso / Low back

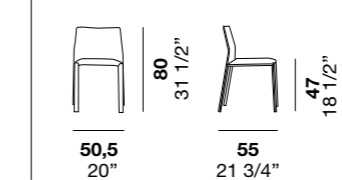

Karol / Karol wood

Con il suo schienale avvolgente, Karol rilassa il corpo ed i pensieri in una curva che continua lungo la linea della seduta e delle gambe, disponibili anche in legno massello. Il rivestimento aggiunge un ulteriore tocco di eleganza.

With its embracing backrest, Karol relaxes the body and calms the mind in an unbroken curve through the line of the seat and legs. This piece is also available in solid wood. The upholstery adds a further touch of elegance.

design R&D Alf DaFrè





Karol sedia / chair
Tessuto Nodone A1311/ Nodone A1311 fabric
L/W50 P/D62 H80





Karol wood sedia / chair
 Gambe noce naturale e tessuto Nodone
 A1304 / Natural walnut legs and Nodone
 A1304 fabric
 L/W50 P/D62 H80

KAROL / KAROL WOOD

design R&D Alf DaFrè

Karol e Karol wood sono sedie imbottite e non sfoderabili. Karol wood abbina gambe in legno ai rivestimenti di seduta e schienale.

Materiali e finiture
 Rivestimento: Tessuto, Pelle, Ecopelle.
 Gambe (Karol wood): Fashion wood, Rovere colori opachi, Colori opachi, Fassino tinto noce.

Karol and Karol wood are padded chairs with not removable covers. Karol wood combines wooden legs with upholstered seat and back.

Materials and finishes
 Covering: Fabric, Leather, Ecoleather.
 Legs (Karol wood): Fashion wood, Oak matt colours, Matt colours, Walnut tinted ash.

Sedia tessuto / Fabric chair

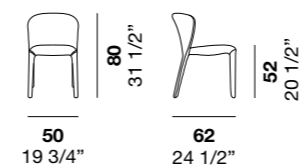

Sedia tessuto e legno / Fabric and wooden chair

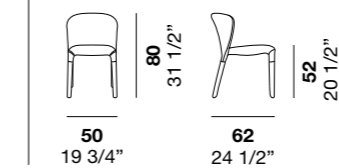

Raku

Raku è una seduta essenziale e accogliente, con schienale e seduta dalle forme arrotondate, sostenute da tubolari metallici che sembrano solo appoggiati sui loro volumi. L'ampia scelta di rivestimenti, in pelle o tessuto, permette un ideale inserimento in ogni contesto d'arredo.

Raku is a welcoming chair with a minimalist design. Backrest and seat with rounded lines are supported by tubular metal legs that appear to be simply resting in place. The wide range of leather or fabric upholstery means this piece can fit perfectly into any interior setting.

design Gordon Guillaumier





Raku sedia / chair
Pelle Lord 9100 / Lord 9100 leather
L/W54,3 P/D55 H78

Raku sedia / chair
Tessuto Nodone A1304/ Nodone
A1304 fabric
L/W55,5 P/D55 H80

Fyra tavolo / table
Fashion wood rovere Carbone / Fashion
wood Carbone oak
L/W200 P/D100 H75,4



RAKU

design Gordon Guillaumier

La collezione di sedute imbottite Raku – che comprende poltrona + pouf, divanetto, sedia e panca – ha un'immagine contemporanea ed essenziale. Seduta e schienale sono definiti da volumi semplici e arrotondati. Il piede, altrettanto essenziale, è formato da un tubo verticale che sembra solo appoggiato all'esterno dei volumi. La panca imbottita prevede anche un bracciolo in legno che la divide trasversalmente creando un funzionale piano di appoggio. Disponibile con rivestimento in pelle e in tessuto, RAKU è perfetta per regalare un tocco di comfort alla zona giorno, come alla zona notte.

Materiali e finiture
 Rivestimento: Tessuti, Pelle, Ecopelle.
 Gambe in metallo: Verniciato Moka Shine.

The Raku collection of upholstered seats – which includes an armchair + footstool, small sofa, chair and bench – has a simple, contemporary look. The seat and back are defined by simple, rounded volumes. The equally simple leg is formed of a vertical bar that looks like it is resting against the outer edge of the chair back. The upholstered bench also has a wooden armrest that divides it widthways, creating a functional surface for resting things on. Available with leather and fabric upholstery, RAKU is perfect for adding a touch of comfort to the lounge and bedroom.

Materials and finishes
 Covering: Fabric, Leather, Ecoleather.
 Metal legs: Painted Moka Shine.

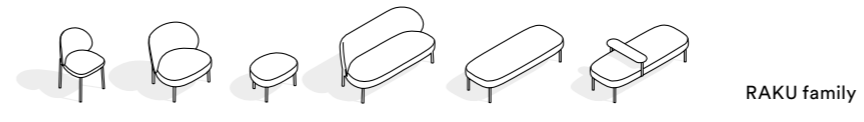

Sedia / Chair

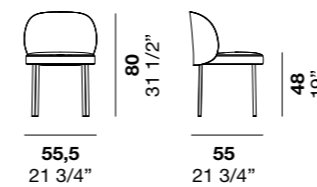

Shift

Telaio, sedile, schienale: il progetto di Shift punta a scomporre la seduta nei suoi elementi fondamentali, evidenziando la loro forma caratteristica e ricercando un innovativo rapporto fra essi. Il risultato è una composizione dinamica, contemporanea e raffinatamente inusuale.

Frame, seat and backrest: the Shift design aims to deconstruct the chair into its fundamental elements, highlighting their characteristic forms and exploring innovative relationships between components. The result is a dynamic, contemporary and elegantly unfamiliar composition.

design Marcello Ziliani



Shift sedia / chair
Fashion wood Rovere Carbone,
tessuto Antibes 802 / Fashion
wood Carbone oak, Antibes
802 fabric
L/W49 P/D54,7 H76,8





Shift sedia / chair
Fashion wood Rovere Fossile e tessuto
Regal E008/ Fossile oak fashion wood and
Regal E008 fabric
L/W49 P/D54,7 H76,8

SHIFT

design Marcello Ziliani

Con Shift ho esplorato la sottile sovversione della regola: l'architettura di un classico modello di sedia viene infatti riconfigurata attraverso la leggera traslazione e rotazione degli elementi lineari del telaio a ritrovare un nuovo equilibrio più dinamico, raffinato, contemporaneo.

Materiali e finiture

Struttura: Roveri laccati opachi, Fashion wood.

Rivestimento: Tessuti, Pelle, Ecopelle.

With Shift I explored a subtle subversion of the rulebook: the architecture of a classic chair model has been reconfigured by gently translating and rotating the linear elements of the frame to find a new more dynamic, elegant and contemporary harmony.

Materials and finishes

Frame: Matt wlacquered oak, Fashion Wood.

Upholstery: Fabric, Leather, Ecological leather.

Sedia / Chair

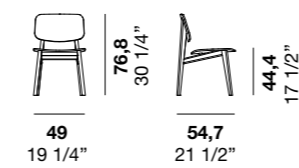

The Italian Home

Una casa dove sistemi, complementi e persone vivono in armonia. Questo è il pensiero chiave di ricerca e sviluppo dei nuovi cataloghi complementi in cui Alf DaFrè ha definito i temi indispensabili del nuovo progettare l'arredo contemporaneo. Personalizzazione, produzione rispettosa dell'ambiente, design ricercato dal punto di vista estetico e funzionale in linea con i nuovi stili e tendenze dell'abitare contemporaneo.

A home where interiors, furniture and people are in harmony. This is the key logic behind research and development for the new catalogues of interiors, in which Alf DaFrè has clearly set out the fundamentals of a new path for contemporary furniture design. Customisation, manufacturing with respect for the environment, refined design in terms of form and function, aligned with new styles and trends in contemporary living.



Alf DaFrè: due nomi che narrano le vite di due giovani italiani cresciuti nel secondo dopoguerra. Alf è Oliviero, carismatico e solare, non ancora maggiorenne quando nel 1957 diventa socio della cooperativa Artigiana Legno Francenigo (Alf). Viaggiando prima per l'Italia e poi nel mondo, in 50 anni renderà Alf uno dei principali produttori di mobili in Italia. DaFrè è Rovilio, severo e ambizioso, appena ventunenne quando nel 1955 fonda il mobilificio DaFrè. Maniaco del dettaglio e amante del design, porterà DaFrè ad essere un marchio riconosciuto per qualità e design. Nel 2008 nasce Alf DaFrè: il talento imprenditoriale di Oliviero si unisce alla ricerca senza compromessi di Rovilio, il sapere industriale Alf si unisce all'anima sartoriale DaFrè per creare sistemi e complementi in armonia con gli ambienti e le persone che li vivono.

Due nomi, due volti



TWO NAMES, TWO FACES

Alf DaFrè: two names telling the stories of two young Italians growing up in the wake of the Second World War. Alf is Oliviero, cheerful and charismatic, and still just a teenager in 1957 when he became a member of the Artigiana Legno Francenigo (Alf) cooperative. Travelling first in Italy and then around the world, over 50 years he made Alf one of Italy's leading furniture producers.

DaFrè is Rovilio, a serious and ambitious character, who founded the DaFrè furniture business in 1955, aged just 21. Obsessed with detail and passionate about design, he transformed DaFrè from unknown brand to symbol of quality and design.

In 2008 Alf DaFrè was born, as the entrepreneurial talent of Oliviero met the uncompromising innovation of Rovilio, and the industrial expertise of Alf met the sartorial spirit of DaFrè, creating interiors and furniture truly in harmony with their surroundings and the people who live in them.



Le persone

Maria Cristina Piovesana, Piero Piovesana e Flavio Da Frè guidano oggi Alf DaFrè, un'azienda nella quale la tradizione familiare ed i valori umani sono i veri patrimoni. In Alf DaFrè ogni mattina inizia con un buongiorno, a prescindere dagli attriti della sera precedente o dalle discussioni a venire. Una tradizione iniziata da Oliviero Piovesana e che prosegue tuttora, simbolo di un approccio affabile e gentile, per ricreare un senso di comunità che trascenda i rapporti professionali.

PEOPLE

Maria Cristina Piovesana, Piero Piovesana and Flavio Da Frè are now at the helm of Alf DaFrè, a company where family tradition and human values are considered the true assets. Every morning at Alf DaFrè must start with a "Good Morning", whatever quibbles there may have been the evening before or disagreements may be to come. This is a tradition introduced by Oliviero Piovesana that continues today; symbolic of a kind and pleasant approach, nurturing a sense of community that transcends professional relationships.

Il territorio

Alf DaFrè ha da oltre 70 anni sede nella provincia di Treviso, al confine tra Friuli e Veneto. Un territorio dove l'abbondante legno, trasportato via acqua e lavorato grazie alla forza motrice delle rogge, ha creato i presupposti per la nascita di una tradizione ebanista che prosegue oggi in Alf DaFrè. Un legame indissolubile con un territorio fatto da persone, scandito dall'alternarsi di Ville Venete, casali di campagna e centri abitati dai tratti veneziani. Un microcosmo di bellezza ed eleganza da cui Alf DaFrè trae continuamente ispirazione e che traspare in ogni suo prodotto e dettaglio.



THE LOCAL AREA

Alf DaFrè has been based in the province of Treviso (Italy), on the border between the Friuli and Veneto regions, for more than 70 years. Wood supplies are plentiful in this area, with the material being transported by water and worked thanks to the driving force of the man-made waterways, which has created the prerequisites for a cabinetmaking tradition that continues today at Alf DaFrè. There's an unbreakable bond between the company and the local area, made up of people, Palladian Veneto villas, country farmhouses, and residential areas with a Venetian flavour. It's a microcosm of beauty and elegance, from which Alf DaFrè draws continuous inspiration, and which permeates every product design and detail.



PRODUCTION

Over 150,000 square metres of production space, where artisan expertise and the combined efforts of a close-knit and highly motivated team come together to create unique interiors and furniture, made by people for people. Investment in people and innovative manufacturing technology. For over a decade, Alf DaFrè has implemented a policy of investment in 4.0 manufacturing systems, combining the productivity and flexibility of a modern company with the care and skilful touch of artisan expertise.

La produzione

Oltre 150.000 mq di spazi produttivi dove, dall'esperienza artigianale e dal lavoro di gruppo delle persone unite e motivate, nascono sistemi e complementi unici, fatti da persone per le persone. Investimenti nelle persone e nell'innovazione tecnologica produttiva. Da oltre un decennio Alf DaFrè promuove una politica d'investimento in impianti produttivi 4.0, coniugando produttività e flessibilità di un'azienda moderna con la cura e la mano invisibile del saper fare artigianale.

Sustainability

Impresa come valorizzazione del territorio



Alf DaFrè ha ampliato i suoi stabilimenti e continua il suo piano di sviluppo nel rispetto dell'ambiente, valutando i suoi impatti ambientali, realizzando un progetto sostenibile con la consapevolezza di essere attore in un sistema in cui capitale naturale e capitale umano devono essere preservati e valorizzati per le generazioni future e per l'intera comunità. Nei piani di sviluppo viene sempre messo in sicurezza idrogeologica il territorio in cui Alf DaFrè opera, proteggendolo dagli allagamenti e tutelando l'ecosistema locale.

A COMPANY WORKING WITH ITS SURROUNDINGS
Alf DaFrè has expanded its production sites and is moving forward with its development plan with respect for the environment, establishing a sustainable project, aware of its role in a system where natural capital and human capital must be safeguarded and promoted for future generations and the community as a whole. Development plans all include attention to the hydrogeological stability of the area in which Alf DaFrè operates, protecting it from flooding and preserving the local ecosystem.

La sostenibilità come un insieme di azioni che Alf DaFrè realizza attraverso una costante razionalizzazione dei processi e delle utenze, incrementando l'efficienza degli impianti che si traduce in un aumento della produttività a parità di consumo energetico. Oltre a controllare le emissioni in atmosfera, Alf DaFrè limita e riduce costantemente le esternalità attraverso azioni chiare e mirate. Vengono internalizzate le lavorazioni per ridurre il traffico su strada e si ottimizza la viabilità per l'accesso ai propri stabilimenti.

Sostenibilità come razionalizzazione



SUSTAINABILITY AS RATIONALISATION
Sustainability is managed as a set of actions implemented by Alf DaFrè through continuous rationalisation of processes and utilities, increasing the efficiency of systems, which translates into increased productivity with equal energy consumption. In addition to controlling atmospheric emissions, Alf DaFrè constantly limits and reduces outsourcing through clear and targeted measures. Processing is performed inhouse to reduce road transport and the road network leading to its sites has been optimised.

Alf DaFrè opera una costante ricerca per fornire materiali di altissima qualità, prediligendo l'uso di finiture all'acqua e materiali ecologici. I pannelli impiegati sono a bassa emissione di VOC e formaldeide secondo le normative EPA e CARB. Una qualità che mira a fornire prodotti che rispettino un principio cardine della sostenibilità, ovvero la durabilità nel tempo. L'attenzione verso i materiali è anche posta alla fase di raccolta differenziata, recupero e riutilizzo di questi, riciclandoli e ottimizzando gli imballaggi.



Costante ricerca nei materiali

CONSTANT RESEARCH INTO MATERIALS

Alf DaFrè carries out constant research in order to offer extremely high-quality materials, prioritising the use of water-based finishes and eco-friendly materials. The panels used have low VOC and formaldehyde emissions as per EPA and CARB regulations. The company strives for quality, enabling products aligned with a core principle of sustainability: durability. Focus is also placed on materials with a view to their separate processing on disposal, enabling their recovery and reuse, and the recycling and optimisation of packaging.

Benessere e valorizzazione delle persone



Per Alf DaFrè il benessere e la valorizzazione delle persone sono principi fondamentali verso il capitale umano. Per questo è stato stilato un Codice Etico che stabilisce i valori e i comportamenti sui quali si fondano le attività e i rapporti con dipendenti e collaboratori: per lavorare bene, in un mondo migliore.

WELLBEING AND PROMOTION OF HUMAN RESOURCES

At Alf DaFrè, ensuring the wellbeing of employees and promoting professional development are key principles in our approach to human capital. This is why a Code of Ethics has been established, setting out the values and conduct which forms the basis of the business and relationships with employees and partners: working well together, for a better world.

Alf DaFre®

ALF UNO Spa
Via S. Pio X 17
31018 Francenigo di Gaiarine
Treviso, Italy
Tel. +39 0438 997111
Fax Italia +39 0438 997245
Fax estero +39 0438 997246
www.alfdafre.it alf@alf.it



ALF UNO Spa
è certificata ISO 9001:2015
ALF UNO Spa
is certified by the ISO 9001:2015

Verifica le finiture disponibili sul nostro sito internet / Check the finishes available on our website www.alfdafre.it

ALF UNO s.p.a. si riserva di apportare in qualsiasi momento modifiche a prodotti, misure e materiali, che ritenesse utili per esigenze di carattere produttivo e commerciale. Per essere sempre aggiornati vi invitiamo a consultare il nostro sito internet www.alfdafre.it. LE FINITURE: I materiali utilizzati dalla nostra azienda sono selezionati tra i più affidabili per applicazione e resa estetica. Nonostante questo devono considerarsi tollerabili alcune differenze dovute alle caratteristiche stesse di materiali come essenze naturali, vetri, laccature e all'artigianalità di alcune fasi del processo produttivo che da sempre è un nostro valore aggiunto. Inoltre alcune finiture possono subire nel tempo maturazioni dovute all'azione della luce e del tempo. È importante quindi specificare se nell'ordine vi sono sostituzioni o completamenti per valutare insieme il miglior modo di procedere. Le tonalità di colore e le finiture illustrate vanno considerate puramente indicative. Verificare sempre la fattibilità dell'abbinamento finiture consultando l'interno del listino.

ALF UNO s.p.a. reserves the right to make any changes to products, measurements and materials at any time deemed useful for manufacturing and sales purposes. To stay up to date at all times, please visit our website www.alfdafre.it. FINISHES: The materials we use are selected among the most reliable products in terms of application and aesthetic rendering. Despite this, certain differences due to the very characteristics of materials such as natural wood finishes, glass and lacquers must be considered tolerable, as well as the hand-crafted nature of certain phases of the production process, which has always been one of our added values. In addition, some finishes may change over time, due to the effects of light and time. It is therefore important to specify whether there are replacements or completions in the order to assess the best way to proceed together. The finishes featured in this sample collection are purely indicative and are not available for all products. Please check in the price list if the finish is available for the chosen item. Orders will not be accepted for products with finishes not included in the price list. The colour shades and finishes illustrated herein are to be considered purely indicative. Always check the feasibility of finish combinations by consulting the price list contents.

art direction **Bruna Vaccher, Genny Canton** / graphic design **Genny Canton Studio** / photo **Paolo Contratti, Paolo Burato, Riccardo Munarin** / styling **Rosanna Bignucolo, Claudia Barberi** / digital image **Nudesign** / separations **Luce srl** / print **Sincromia**

thanks to **G.T.Design, Panzeri**