



*italian
artisan
beauty*

Tonin

CASA

italian artisan beauty

La collezione Italian Artisan Beauty di Tonin Casa mette in luce e valorizza le eccellenze del territorio per qualità dei materiali, creatività e artigianalità.

Una maestria artigianale da valorizzare e far conoscere a tutti i clienti Tonin Casa.

Tonin Casa's Italian Artisan Beauty collection highlights and enhances the area's excellence in material quality, creativity and craftsmanship.

A craftsmanship to be enhanced and made known to all Tonin Casa customers.

INDICE - INDEX



ABLOS 8



ARCO EXT 14



ARCO MAXI 18



MILLERIGHE 24



OLIVER 28



SIMPOSIO 34



SIPARIO 38



SIPARIO EXT 42



STYLE ROUND EXT 46



THUNDER SILK WOOD 52



TRAVERTINO COLLECTION 56



ASTRA 68



BUSTIER 72



CAMILA 74

SEDUTE/ CHAIRS
SGABELLI/ STOOLS



GAIA 80



BUSTIER STOOL 84



ADONE PLISSÉ 130



ARCO 132



REVERSE 134

MADIE/ SIDEBARDS



APOGEO 86



BONNIE 90

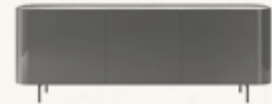

CLYDE 94

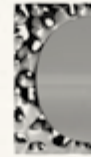

AFRODITE 136



AFRODITE MAXI 140



ARKÉ 144



CLYDE PORTA TV 98

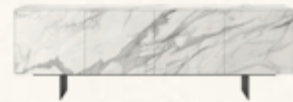

CRISTALIA 100



LUCE 104



EDEN 146



EOS 150



GALILEO 154



MONOLITE EMPERADOR 108



OFF 112



PATSY 116



PITTI 156



VOX 160

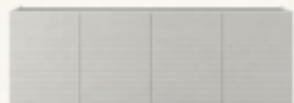

PATSY ÉLITE 118



SAFFIRA 122



SELENE 126



ARTURO ARTISTIC GLASS 162



ATOLLO 166



GIUDECCA 170

CONSOLLE/ CONSOLE

SPECCHI/ MIRRORS

TAVOLINI/ COFFEE TABLES



IDDU 172

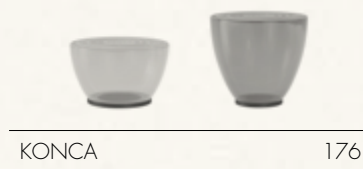

KONCA 176



SOFFIO 178



SOFFIO ÉLITE 180



CHECKER 184

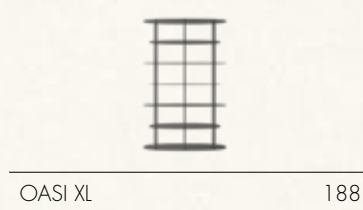

OASI XL 188



AGATA LOUNGE 192



DOMUS 196



MONTECARLO 202



ALIANTE 206



BULL 210

INDICE - INDEX



CRISTALLIA NIGHT 214



PATSY NIGHT 218



ANDROMEDA 222



CORTINA 224

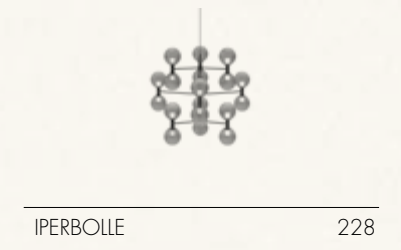

IPERBOLLE 228



LANTERNA 232



MOOD 236



PETALO 238



VENICE MOON 240



VASI SOFFIO 244



ROMEO 246

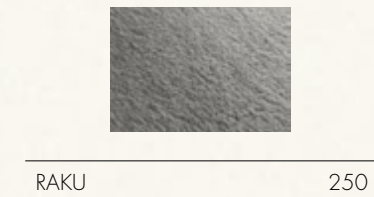

RAKU 250



RILA 252

ablos

Andrea Andretta Studio

Ablos è un'espressione di leggerezza e movimento, un equilibrio perfetto tra forza e delicatezza. La sua base, formata da due lastre in vetro curvato martellato trasparente, sostiene un piano asimmetrico, sempre dello stesso materiale. I giochi di riflessi che si creano all'incontro della luce con il vetro danno vita ad un'atmosfera vibrante ed eterea. Adatto anche per l'uso outdoor.

Ablos is an expression of lightness and movement, a perfect balance between strength and delicacy. Its base, formed by two curved sheets of transparent hammered glass, supports an asymmetrical top in the same materials. The play of reflections when light hits the glass creates a vibrant, ethereal atmosphere. Suitable also for outdoor.

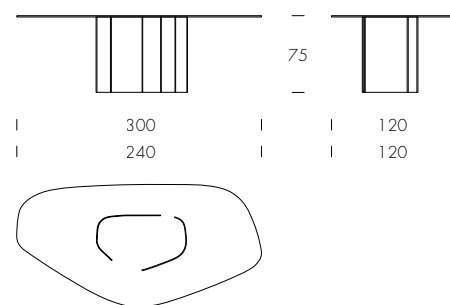

Ablos_tavolo/table
struttura vetro trasparente martellato fumé/
fumé hammered transparent glass structure (MVO3)

Altri elementi:
sedie Bustier, sedia Saffira, specchio Vox,
tappeto Raku, lampade Lanterna/
Other items:
Bustier chairs, Saffira sideboard,
Vox mirror, Raku rug, Lanterna lamps



Ablos_tavolo/table
 struttura vetro trasparente martellato fumé/
 fumé hammered transparent glass structure (MVO3)

Altri elementi:
 sedie Bustier, sedia Saffira, tappeto Raku,
 lampade Lanterna/
 Other items:
 Bustier chairs, Saffira sideboard, Raku rug,
 Lanterna lamps



Ablos tavolo/table
struttura vetro trasparente martellato bronzo/
bronze hammered transparent glass structure (MV04)

Altri elementi:
sedie Camila, tappeto Raku,
lampade Etoile, carrello Oblò/
Other items:
Camila chairs, Raku rug,
Etoile lamps, Oblò trolley

arco ext

Angelo Tomaiuolo | Ernesto Barbieri

Il tavolo Arco reinterpreta l'architettura classica con una base in legno termocurvato ispirata all'arco a tutto sesto. Unisce tradizione e modernità, coniugando solidità e leggerezza in un design elegante. Il piano, disponibile in ceramica effetto marmo e altre finiture pregiate, esalta il suo prestigio. Dotato di un sistema di allungamento, Arco si adatta con versatilità, diventando il fulcro di momenti di condivisione senza tempo.

Arco table reinterprets classical architecture with a thermo-curved wooden base inspired by the round arch. It combines tradition and modernity, solidity and lightness in an elegant design. The top, available in marble effect ceramics and other fine finishes, enhances its prestige. Equipped with an extension system, Arco adapts with versatility, becoming the centre of timeless moments of sharing.

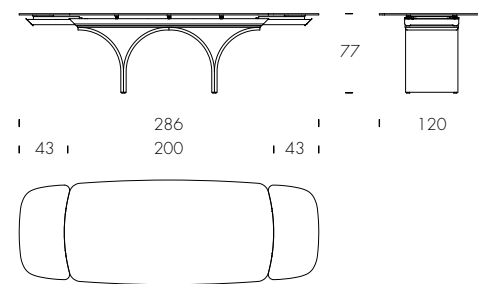

Arco Ext_tavolo/table
struttura in frassino nero, top in gres Calacatta Vena Vecchia/
structure in black ash (25),
top in Calacatta Vena Vecchia porcelain stoneware (V_62P)



Arco Ext tavolo/table
struttura in frassino nero, top in gres Calacatta Vena Vecchia/
structure in black ash (25),
top in Calacatta Vena Vecchia porcelain stoneware (V_62P)

Altri elementi:
sedie Gaia, tappeto Rila,
lampade Etoile, sedia Clyde /
Other items:
Gaia chairs, Rila rug,
Etoile lamps, Clyde sideboard

arco maxi

Angelo Tomaiuolo | Ernesto Barbieri

Il tavolo Arco rinasce nella sua versione Maxi. Due eleganti archi rivestiti in legno sorreggono l'ampio piano in vetro stampato, che mette in risalto le venature delle preziose finiture Crystal Calacatta e Calacatta Black.

The Arco table is reborn in its Maxi version. Two elegant wood-covered arches support the wide printed glass top, which highlights the veining of the precious Crystal Calacatta and Black Calacatta finishes.

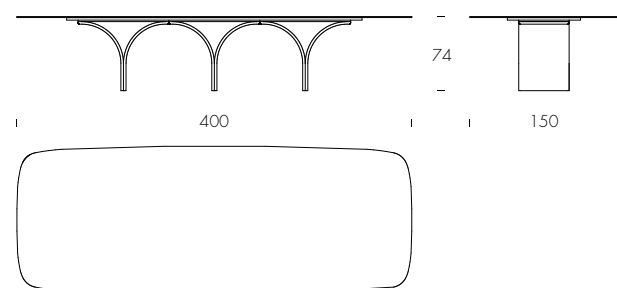

Arco Maxi tavolo/table
base in noce canaletto,
top in vetro con stampa digitale Crystal Calacatta/
canaletto walnut base (14),
Crystal Calacatta digitally printed glass top (ST02)

Arco Maxi _tavolo/table
base in noce canaletto,
top in vetro con stampa digitale Crystal Calacatta/
canaletto walnut base (14),
Crystal Calacatta digitally printed glass top (ST02)

Altri elementi:
sedie Mivida, lampade Venice Moon, vasi Soffio, tappeto Pixel/
Other items:
Mivida chairs, Venice Moon ceiling lamps, Soffio vases, Pixel rug





Arco Maxi _tavolo/table
base in noce canaletto,
top in vetro con stampa digitale Crystal Calacatta/
canaletto walnut base (14),
Crystal Calacatta digitally printed glass top (ST02)

Altri elementi:
sedie Mivida, vasi Soffio, tappeto Pixel/
Other items:
Mivida chairs, Soffio vases, Pixel rug

millerighe

Ernesto Barbieri

Il tavolo Millerighe è una sintesi equilibrata ed armonica tra forza e leggerezza, che dialoga con luce e spazio grazie alla sua struttura in vetro fuso rigato. Le basi simmetriche, curvate con eleganza, sostengono un piano a botte, esaltando la solidità del vetro e la fluidità della forma. La particolare finitura del vetro crea giochi di riflessi con la luce che rendono ogni spazio raffinato e dinamico.

Millerighe table is a balanced and harmonious synthesis of strength and lightness that creates a dialogue with light and space, thanks to its ribbed structure in cast glass. The symmetrical, elegantly curved legs support a barrel-shaped top that enhances the solidity of the glass and the fluidity of the shapes. The special finish of the glass creates reflections that make any space both refined and dynamic.

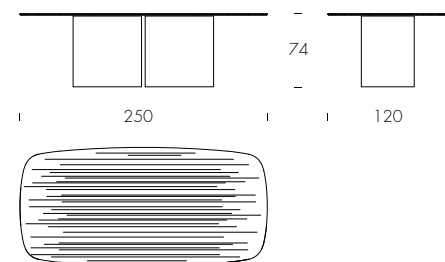

Millerighe tavolo/table
struttura vetro trasparente
fumé effetto rigato/
fumé transparent glass structure
with a ribbed effect (V_86)

Altri elementi:
sedie Olympia, tappeto Raku/
Other items:
Olympia chairs, Raku rug



Millerighe tavolo/table
struttura vetro trasparente fumé effetto rigato/
fumé transparent glass structure with a ribbed effect (V_86)

Altri elementi:
sedie Olympia, madia Cristallo, specchio Afrodite Maxi,
lampade Mood, tappeto Raku/
Other items:
Olympia chairs, Cristallo sideboard, Afrodite Maxi mirror,
Mood lamps, Raku rug

oliver

Maurizio Varsi

Il tavolo Oliver rappresenta la perfetta fusione architettonica tra materiali: il basamento, costituito da metallo verniciato e legno massello, sostiene un piano rettangolare in vetro o a botte in ceramica.

The Oliver table represents the perfect architectural fusion of materials: the powder-coated metal and solid wood base supports a rectangular glass or a barrel top in porcelain stoneware.

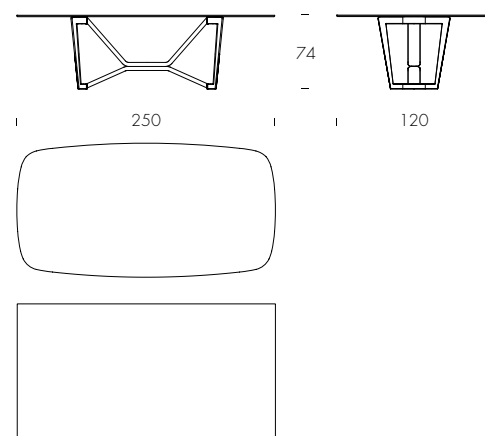

Oliver_tavolo/table
base in metallo grigio carbone e noce canaletto,
top in vetro extrachiaro trasparente bisellato/
Carbon grey powder coated metal and canaletto walnut base (14),
Transparent extra clear beveled glass top (V_100B)

Altri elementi:
sedie Camila, lampade a sospensione Lanterna, tappeto Rila/
Other items:
Camila chairs, Lanterna ceiling lamps, Rila rug



Oliver_tavolo/table

Base in metallo grigio carbone e noce canaletto,
top in vetro extrachiaro trasparente bisellato/
Carbon grey powder coated metal (10) and canaletto walnut base (14),
Transparent extra clear beveled glass top (V100B)

Altri elementi:

sedie Camila, lampade a sospensione Lanterna, tappeto Rila, vetrina Dot/
Other items:
Camila chairs, Lanterna ceiling lamps, Rila rug, Dot showcase



^ Oliver_tavolo/table

Dettaglio base in metallo bronzo pietra e noce canaletto;
 dettaglio top a botte in gres porcellanato Macchiavecchia lucido/
 Detail of stone bronze powder coated metal (83) and canaletto walnut base (14);
 detail of glossy Macchiavecchia barrel porcelain stoneware top (V_87P)

< Oliver_tavolo/table

Dettaglio base in metallo grigio carbone e noce canaletto;
 dettaglio top in vetro extrachiaro trasparente bisellato/
 Detail of carbon grey powder coated metal (10) and canaletto walnut base (14);
 detail of transparent extra clear beveled glass top (V100B)

simposio

Angelo Tomaiuolo | Ernesto Barbieri

Simposio è un tavolo che unisce rigore geometrico e leggerezza visiva, ispirandosi all'antica tradizione del convivio. Il basamento in metallo, dalle linee decise e simmetriche, sostiene con eleganza un piano personalizzabile in ceramica o altre finiture pregiate. Pensato per ambienti moderni e sofisticati, rappresenta un equilibrio perfetto tra estetica e funzionalità, diventando un'icona di design senza tempo.

Simposio is a table that combines geometric rigour and visual lightness, inspired by the ancient tradition of conviviality. The metal base, with its solid, symmetrical lines, elegantly supports a customisable top in ceramic or other fine finishes. Designed for modern and sophisticated interiors, it represents a perfect balance between aesthetics and functionality, becoming a timeless design icon.

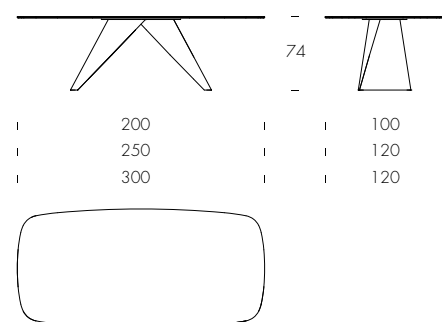

Simposio_tavolo/table
base in metallo bronzo pietra,
top in gres porcellanato Taj Mahal/
stone bronze powder coated metal base (83),
Taj Mahal porcelain stoneware top (V_61P)

Altri elementi:
sedie Agata, lampada Andromeda, tappeto Vintage,
madia Luce, carrello Venanzio/
Other items:
Agata chairs, Andromeda lamp, Vintage rug,
Luce sideboard, Venanzio trolley



Simposio_tavola/table

base in metallo bronzo pietra,
top in gres porcellanato Taj Mahal/
stone bronze powder coated metal base (83),
Taj Mahal porcelain stoneware top (V_61P)

Altri elementi:
sedie Agata, lampada Andromeda, tappeto Vintage,
madia Luce, libreria Sintesi/
Other items:
Agata chairs, Andromeda lamp, Vintage rug,
Luce sideboard, Sintesi bookshelf

sipario

Angelo Tomaiuolo

Il tavolo Sipario unisce stabilità e raffinatezza con un design scenografico ispirato al palcoscenico. Il basamento in metallo, dalla forma scultorea e dinamica, sostiene con eleganza un piano in ceramica o altre finiture pregiate. Perfetto per ambienti sofisticati, è un'icona di stile che trasforma ogni momento in un'esperienza memorabile.

Sipario table combines stability and refinement with a stage-inspired design. The metal base, with its sculptural and dynamic shape, elegantly supports a ceramic or other fine finish top. Perfect for sophisticated settings, it is a style icon that turns every moment into an unforgettable experience.

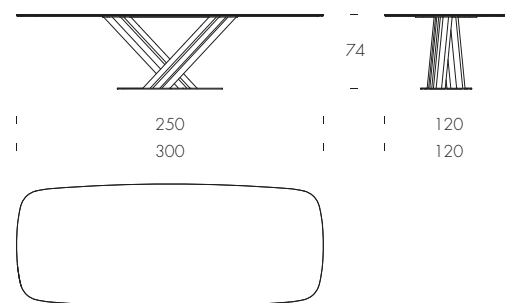

Sipario_tavolo/table
struttura basalto opaco,
top gres porcellanato Aubisque/
Matt basalt structure (87),
Aubisque porcelain stoneware top [V_60P]

Altri elementi:
sedie Camila, lampade Venice Moon, tappeto Raku/
Other items:
Camila chairs, Venice Moon lamps, Raku rug



Sipario_tavolo/table
 struttura basalto opaco,
 top gres porcellanato Aubisque/
 Matt basalt structure (87),
 Aubisque porcelain stoneware top (V_60P)

Altri elementi:
 sedie Camila, lampade Venice Moon,
 tappeto Raku/
 Other items:
 Camila chairs, Venice Moon lamps, Raku rug

sipario ext

Angelo Tomaiuolo | Ernesto Barbieri

Anche nella versione allungabile il tavolo Sipario unisce stabilità e raffinatezza con un design scenografico ispirato al palcoscenico. Il basamento in metallo, dalla forma scultorea e dinamica, sostiene con eleganza un piano in ceramica. Perfetto per ambienti sofisticati, è un'icona di stile che trasforma ogni momento in un'esperienza memorabile.

Also for the extendable version Sipario table combines stability and refinement with a stage-inspired design. The metal base, with its sculptural and dynamic shape, elegantly supports a ceramic top. Perfect for sophisticated settings, it is a style icon that turns every moment into an unforgettable experience.

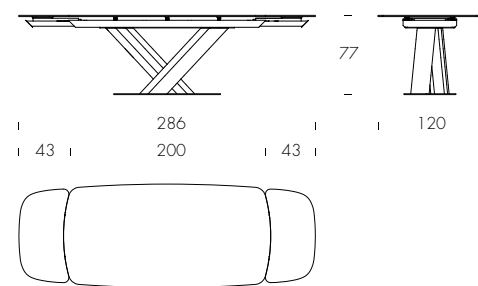

Sipario tavolo/table
struttura grigio carbone,
top travertino silver/
Carbon Grey structure (10),
travertino silver top (V_22P)

Altri elementi:
sedie Astra, lampade Venice Moon, vetrine Venus/
Other items:
Astra chairs, Venice Moon lamps, Venus showcases



Sipario tavolo/table
struttura grigio carbone, top travertino Silver/
Carbon Grey structure (10), travertino Silver top (V_22P)

Altri elementi:
sedie Astra, lampade Venice Moon, vetrine Venus/
Other items:
Astra chairs, Venice Moon lamps, Venus showcases

style round ext

Ernesto Barbieri

Il tavolo Style Round Ext completa la famiglia Style con la versione tonda allungabile; la base in acciaio verniciato è caratterizzata da incroci e sovrapposizioni, il top tondo in ceramica si contraddistingue grazie all'allunga rivestita in legno, perfettamente integrata al resto del piano.

The Style family of tables is enriched with Style Round Ext, the first extensible round table; the painted steel base features crisscrossing and overlapping, and the round porcelain stoneware top stands out thanks to the wood-covered extension, perfectly integrated with the rest of the top.

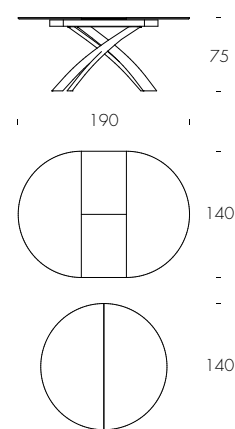

Style Round Ext tavolo/table
base metallo verniciato grigio carbone,
top in gres Alaska White, inserti in frassino nero/
Carbon grey powder coated base (10),
Alaska White porcelain stoneware top (V_17P),
black ash wooden covered extension (25)

Altri elementi:
sedie Gaia, lampade Venice Moon, tappeto Gea/
Other items:
Gaia chairs, Venice Moon lamps, Gea rug



Style Round Ext_tavolo/table
 base metallo verniciato grigio carbone,
 top in gres Alaska White, inserti in frassino nero/
 Carbon grey powder coated base (10),
 Alaska White porcelain stoneware top (V_17P),
 black ash wooden covered extension (25)

Altri elementi:
 sedie Gaia, madia Monolite, tappeto Gea/
 Other items:
 Gaia chairs, Monolite sideboard, Gea rug



Style Round tavolo/table
base metallo verniciato bronzo pietra,
top in gres Tundra, inserti in noce canaletto/
Stone bronze powder coated base (83),
Tundra porcelain stoneware top (V_19P), canaletto
walnut covered extension (14)

Altri elementi:
sedie Gaia, lampade Andromeda, tappeto Raku/
Other items:
Gaia chairs, Andromeda lamps, Raku rug

thunder silk wood

Maurizio Varsi

La serie dei tavoli Thunder si arricchisce della versione con top in legno Silk Wood, finitura dall'effetto setoso che sorprende al tatto, resa ancora più particolare dal bisello perimetrale a sezione diamantata.

The Thunder table series is enriched by the version with a top in Silk Wood, a finish with a silky effect that is surprising to the touch, made even more special by the perimeter bevel with diamond profile.

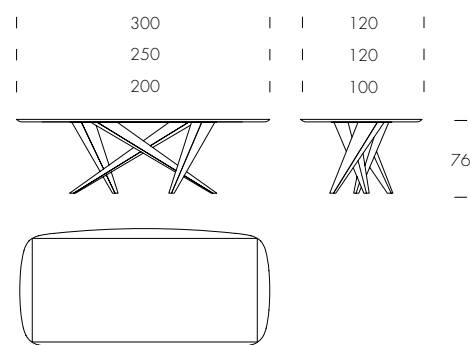

Thunder Silk Wood tavolo/table
base metallo verniciato grigio carbone,
top in noce canaletto/
Carbon grey powder coated base (10),
canaletto walnut top (14)

Altri elementi:
sedie Bustier, lampade Andromeda,
tappeto Vintage, vasi Botanika, libreria Honeybook/
Other items:
Bustier chairs, Andromeda lamps, Vintage rug,
Botanika vases, Honeybook bookshelf



Thunder Silk Wood tavolo/table
base metallo verniciato grigio carbone/
top in noce canaletto/
Carbon grey powder coated base (10),
canaletto walnut top (14)

Altri elementi:
sedie Bustier, lampade Andromeda,
tappeto Vintage, vasi Botanika, libreria Honeybook/
Other items:
Bustier chairs, Andromeda lamps, Vintage rug,
Botanika vases, Honeybook bookshelf

travertino collection

La collezione di piani in travertino si caratterizza per l'effetto naturale di grande bellezza e la resistenza che dona ai tavoli. I piani sono disponibili in una gamma di quattro tonalità e venature, che consente di creare elementi d'arredo unici e distintivi; la loro superficie liscia e levigata aggiunge un tocco di raffinatezza ed eleganza a qualsiasi ambiente. I piani in travertino sono disponibili per i tavoli Arco, Blade, Reverse, Tenso, Brooklyn, Butterfly, Cube, Still.

Travertino tables collection is characterised by its beautiful natural effect and the strength it gives to tables. The table tops are available in a range of 4 tones and veins, allowing the design of unique and distinctive furnishings; the smooth and honed surface adds a touch of refinement and elegance to any space. Travertino tops are available for Arco, Blade, Reverse, Tenso, Brooklyn, Butterfly, Cube, Still tables.



V_20P Travertino Bianco
White Travertino



V_21P Travertino Beige
Beige Travertino



V_23P Travertino Noce
Walnut Travertino



V_22P Travertino Silver
Silver Travertino



Tenso travertino_tavolo/table
Base metallo verniciato oro opaco,
top in travertino bianco/
Gold powder coated base (85),
white travertino top (V_20P)

Altri elementi:
sedie Olympia, libreria Tweet, lampade Mandala/
Other items:
Olympia chairs, Tweet bookshelf, Mandala lamps



Tenso travertino_tavolo/table
 Base metallo verniciato oro opaco,
 top in travertino bianco/
 Gold powder coated base (85),
 white travertino top (V_20P)

Altri elementi:
 sedie Olympia, libreria Tweet, lampade Mandala/
 Other items:
 Olympia chairs. Tweet bookshelf, Mandala lamps



Arco travertino_tavolo/table
Base noce canaletto,
top in travertino beige/
canaletto walnut base (14),
beige travertino top (V_21P)

Altri elementi:
sedie Mivida, lampade Etoile, tappeto Gea, vasi Botanika/
Other items:
Mivida chairs, Etoile lamps, Gea rug, Botanika vases



Arco travertino_tavola/table

Base noce canaletto,
top in travertino beige/
canaletto walnut base (14),
beige travertino top (V_21P)

Altri elementi:

sedie Mivida, lampade Etoile, tappeto Gea, vasi Botanika/
Other items:
Mivida chairs, Etoile lamps, Gea rug, Botanika vases



Reverse travertino_tavolo/table
 Base metallo grigio carbone,
 top in travertino silver/
*Carbon grey powder coated base (10),
 Silver travertino top (V_22P)*

Altri elementi:
 sedie Agata, madia Patsy, specchio Eden, libreria Oasi, tappeto Gea/
Other items:
Agata chairs, Patsy sideboard, Eden mirror, Oasi bookshelf, Gea rug



Butterfly travertino_tavolo/table
 Base in frassino nero,
 top in travertino noce/
 Black ash base (25),
 Walnut travertino top (V_23P)

Altri elementi:
 sedie Malva, lampade Atomo, tappeto Vintage, carrello Oblò/
 Other items:
 Malva chairs, Atomo lamps, Vintage rug, Oblò trolley

astra

Cristian Dal Bianco

Una linea curva accoglie il corpo con naturalezza, disegnando uno spazio intimo, rassicurante. Questa poltroncina nasce dall'incontro tra forma e funzione: la struttura snella si accompagna a un'imbottitura generosa, che invita alla sosta. Una presenza silenziosa, ma decisa fatta per durare, pensata per essere vissuta.

A curved line naturally embraces the body, creating an intimate, reassuring space. This small armchair is the result of a synthesis of form and function: the slender structure is accompanied by generous upholstery, inviting you to linger. A silent but decisive presence, made to last, designed to be experienced.

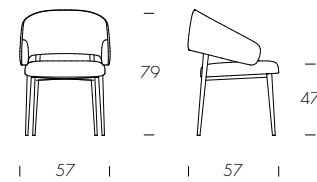

Astra_sedia/chair
base grigio carbone,
rivestimento in tessuto Kimono Ottanio/
carbon grey base (10),
Octane Kimono fabric upholstery (KM801)



Astra_sedia/chair
base grigio carbone,
rivestimento in tessuto Kimono Ottanio/
carbon grey base (10),
Octane Kimono fabric upholstery (KM801)

bustier

Ernesto Barbieri

La sedia Bustier con struttura in metallo verniciato è disponibile con rivestimento in tessuto, pelle, ecopelle o velluto. Il retroschienale con trapuntatura "bustier" richiama il corpino, simbolo di grazia e sensualità femminile.

Bustier chair with a powder coated metal frame, is available with fabric, leather, ecoleather or velvet upholstery. The backrest's 'bustier' quilting is reminiscent of the bodice - a symbol of feminine grace and sexuality.

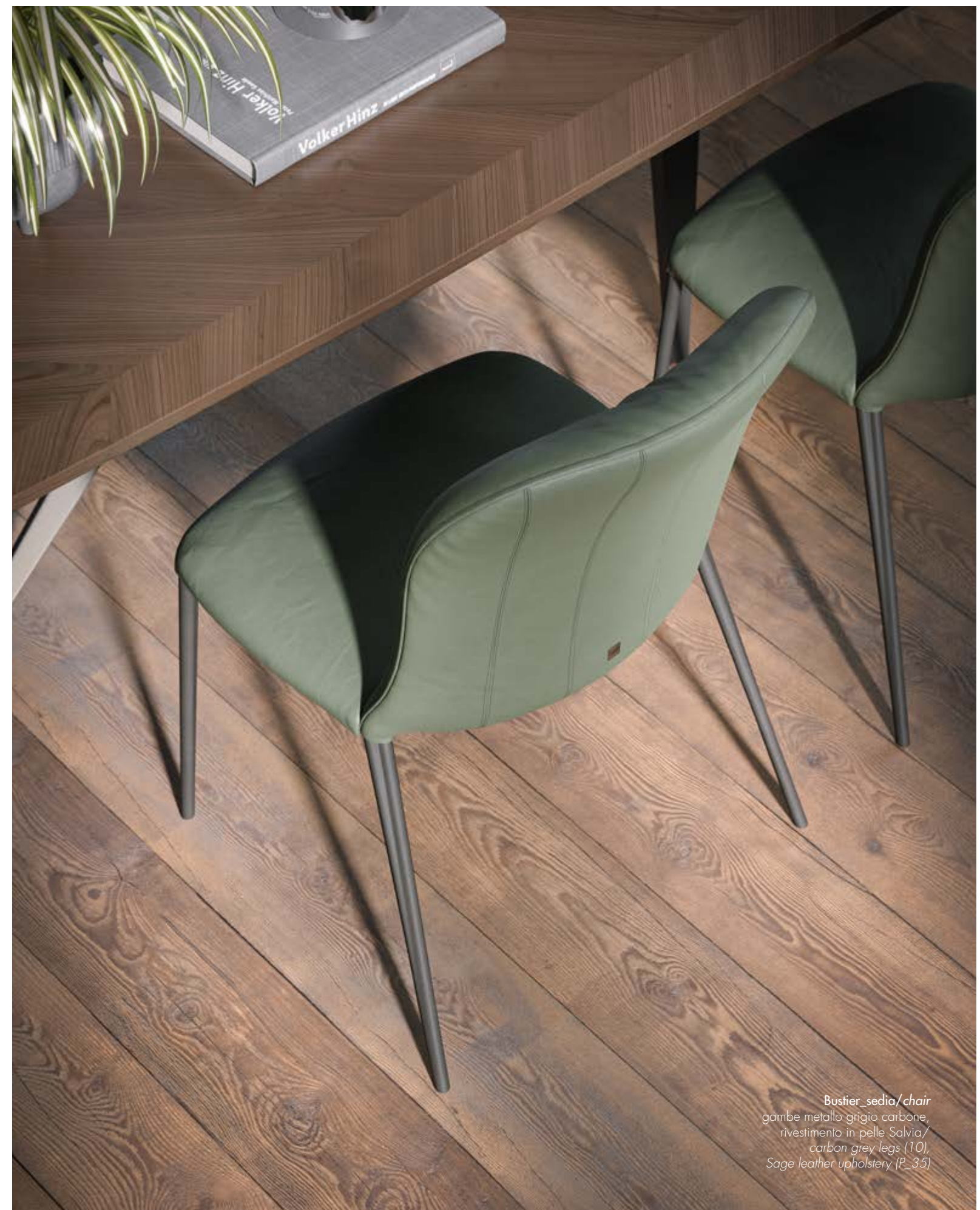
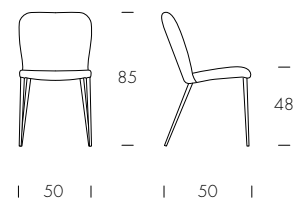

Bustier_sedia/chair
gambe metallo grigio carbone,
rivestimento in pelle Salvia/
carbon grey legs (10),
Sage leather upholstery (P_35)

camila

Luca Roccadadria

La sedia Camila si distingue per il suo equilibrio tra forme essenziali e comfort raffinato. La seduta imbottita, soffice e accogliente, è valorizzata dal contrasto con la solida struttura in legno massello, che ne sottolinea la silhouette. Lo schienale, leggero e deciso, interrompe visivamente le linee delle gambe posteriori, creando un dinamico gioco di volumi e proporzioni.

Camila chair is characterised by its balance of essential lines and refined comfort. The upholstered seat, soft and cosy, is enhanced by the contrast with the solid wooden frame, which emphasises its silhouette. The light and firm back, breaks the lines of the rear legs, creating a dynamic play of volumes and proportions.

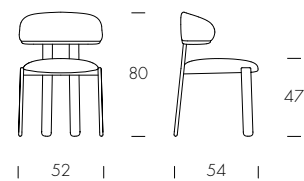

Camila_sedia/chair
struttura in frassino nero,
rivestimento in tessuto Vega Caramello/
black ash structure (25),
Caramel Vega fabric upholstery (T23V)



Camila_sedia/chair
struttura in frassino nero,
rivestimento in tessuto Vega Caramello/
black ash structure (25),
Caramel Vega fabric upholstery (T23V)



Camila_sedia/chair
 struttura noce canaletto, rivestimento in pelle beige/
 canaletto walnut structure (14), beige leather upholstery (P_36)

Altri elementi:
 tavolo Oliver, lampade Andromeda/
 Other items:
 Oliver table, Andromeda lamps

gaia

Ernesto Barbieri

Comfort e naturalezza sono le caratteristiche peculiari della seduta Gaia, resa avvolgente ed accogliente grazie alla generosa imbottitura e ai braccioli ergonomici. Le gambe in metallo conferiscono leggerezza ed eleganza.

Comfort and naturalness are the hallmarks of the Gaia seat, made enveloping and cosy by the generous upholstery and the ergonomic armrests. The metal legs add lightness and elegance.

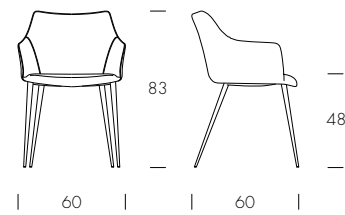

Gaia sedia/chair
gambe metallo grigio carbone,
rivestimento in tessuto Bouclé bianco grigio/
carbon grey legs (10),
white grey Bouclé fabric upholstery (TB900)



Gaia_sedia/chair
gambe metallo grigio carbone,
rivestimento in pelle terra di Siena/
carbon grey legs (10),
terra di Siena leather upholstery (P_37)

bustier stool

Ernesto Barbieri

Ispirato all'omonima sedia, lo sgabello Bustier unisce eleganza e comfort. La struttura in metallo verniciato si abbina a rivestimenti in tessuto, pelle, ecopelle o velluto. Il retroschienale, con l'iconica trappuntatura "bustier", richiama il corpetto femminile, simbolo di grazia e sensualità.

The Bustier stool combines elegance and comfort, and was inspired by the chair of the same name. It has a powder-coated metal frame and is upholstered in fabric, leather, eco-leather or velvet. The backrest's iconic 'bustier' quilting recalls the bodice of a woman's dress, a symbol of grace and sensuality.

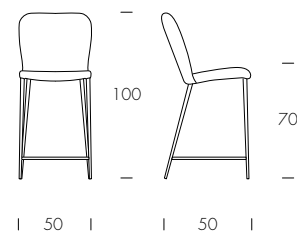

Bustier_sgabello/stool
struttura bronzo pietra,
rivestimento in pelle beige/
stone bronze structure (83),
beige leather upholstery (P_36)

apogeo

Massimo Mottin | Ernesto Barbieri

Realizzata con materiali di alta qualità e con una minuziosa cura artigianale, la madia Apogeo combina la struttura in frassino con la solidità e l'eleganza delle ante in marmo lavorato su disegno geometrico, rappresentando il connubio perfetto tra natura e design.

Made with high-quality materials and meticulous craftsmanship, the Apogeo sideboard combines an ash frame with the solidity and elegance of geometrically worked marble doors, representing the perfect marriage of nature and design.

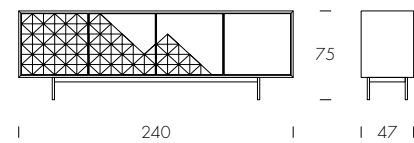

Apogeo_madia/sideboard
base verniciato grigio carbone, struttura in frassino nero,
frontali in marmo Grigio Carnico/
Carbon grey powder coated base (10),
black ash structure (25) Carnic Grey marble doors



Apogeo_madia/sideboard
base verniciato grigio carbone, struttura in frassino nero,
frontali in marmo Grigio Carnico/
Carbon grey powder coated base (10),
black ash structure (25) Carnic Grey marble doors

Altri elementi: panca Ginger/
Other items: Ginger bench

bonnie

Massimo Mottin | Ernesto Barbieri

Perfetta da ogni prospettiva, grazie alle sue rifiniture impeccabili su tutti i lati, Bonnie diventa protagonista assoluta dello spazio, libera di esprimere la sua bellezza anche al centro della stanza.

Perfect from every viewpoint, thanks to its impeccable finish on all sides, Bonnie becomes the absolute highlight of the space, free to express its beauty even in the centre of the room.

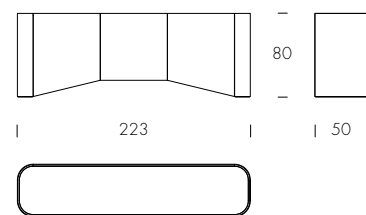

Bonnie_madia/sideboard
struttura laccato cipria 100 gloss, top in specchio bronzo/
100 gloss Cipria structure (92), bronze mirror top (VS_83)

Altri elementi: specchio Pitti, portafiori Romeo/
Other items: Pitti Mirror, Romeo flower stand



Bonnie_madia/sideboard
 Struttura cipria 100 gloss,
 top in specchio bronzo/
 100 gloss cipria structure (92),
 bronze mirror top (VS_83)

Altri elementi:
 specchio Pitti, portafiori Romeo/
 Other items:
 Pitti mirror, Romeo flower stand

clyde

Massimo Mottin | Ernesto Barbieri

Le linee smussate di Clyde avvolgono lo spazio con dolcezza, mentre la laccatura su tutti i lati la rende perfetta per essere ammirata da ogni prospettiva. I sottili piedini in metallo verniciato la sollevano da terra, donandole un senso di leggerezza e sospensione.

Clyde's bevelled lines gently envelop the space, while the lacquering on all sides makes it perfect to admire from all angles. The narrow powder coated metal legs lift it off the floor, giving it a sense of lightness and suspension.

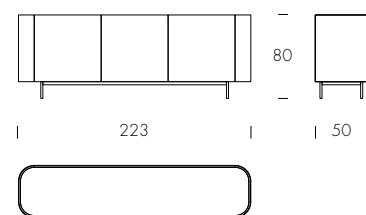

Clyde_madia/sideboard
struttura laccato basalto 100 gloss,
top in gres Calacatta Vena Vecchia/
100 gloss basalt structure (93),
Vena Vecchia Calacatta porcelain top (V_62P)

Altri elementi: specchio Eos/
Other items: Eos Mirror



Clyde_madia/sideboard
 Struttura basalto 100 gloss,
 top in gres Calacatta Vena Vecchia/
 100 gloss basalt structure (93),
 Vena Vecchia Calacatta porcelain top (V_62P)

Altri elementi: specchio Eos/
 Other items: Eos mirror

clyde porta tv

Massimo Mottin | Ernesto Barbieri

Anche nella versione porta tv, le linee smussate di Clyde avvolgono lo spazio con dolcezza, mentre la laccatura su tutti i lati la rende perfetta per essere ammirata da ogni prospettiva, regalando una silhouette con dettagli raffinati e morbide linee.

Even the TV stand version features Clyde's rounded lines, which gently envelop the space. The lacquer finish on all sides makes it perfect for admiring from every angle, and it boasts a silhouette with refined details and soft lines.

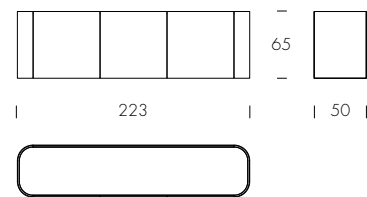

Clyde_porta tv/tv stand
struttura laccato basalto 100 gloss,
top in gres Calacatta Vena Vecchia/
100 gloss basalt structure (93),
Vena Vecchia Calacatta porcelain top (V_62P)

cristalia

Massimo Mottin | Ernesto Barbieri

La madia Cristalia, rivestita in vetro stampato Crystal Calacatta o Calacatta Black, richiama la bellezza senza tempo del marmo, con venature delicate che danzano sulla superficie, creando un gioco di luce e profondità unico. Il basamento in metallo verniciato ne esalta la leggerezza.

Cristalia sideboard, with painted glass Crystal Calacatta or Black Calacatta finishes, evokes the timeless beauty of marble, with delicate veins dancing on the surface, creating a unique play of light and depth. The lacquered metal base enhances its lightness.

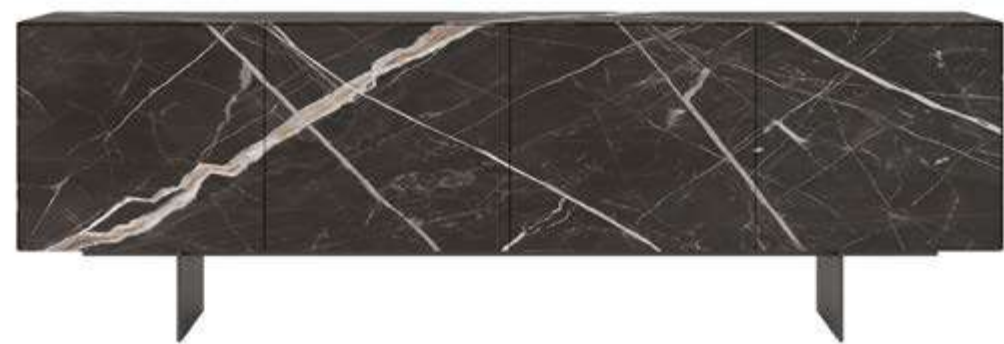
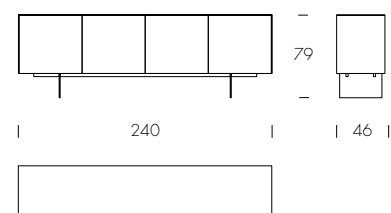

Cristalia_madia/sideboard
Base bronzo pietra,
struttura in vetro stampato Crystal Calacatta/
stone bronze base (83),
Crystal Calacatta printed glass structure (ST02)



Cristalia_madia/sideboard
Base bronzo pietra,
struttura in vetro stampato Crystal Calacatta/
stone bronze base (83),
Crystal Calacatta printed glass structure (ST02)

Altri elementi:
specchio Pitti, lampada Klimt/
Other items:
Pitti mirror, Klimt table lamp

luce

Ernesto Barbieri

La madia Luce si distingue per la struttura in pregiato legno laccato, esaltata da ante in vetro specchio, lavorate con un elegante motivo geometrico. La brillantezza del vetro crea un sofisticato gioco di riflessi che dona luminosità e carattere all'ambiente. Ideale per spazi living dallo stile ricercato.

Luce sideboard stands out for its refined lacquered wood structure, enhanced by mirror glass doors featuring an elegant geometric pattern. The brilliance of the glass creates a sophisticated play of reflections, bringing light and character to the space. Perfect for living areas with a refined and contemporary style.

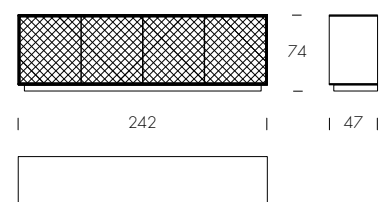

Luce_madia/sideboard
Struttura champagne opaco,
ante in specchio bronzo/
matt champagne structure (60),
bronze mirror doors (VS_83)

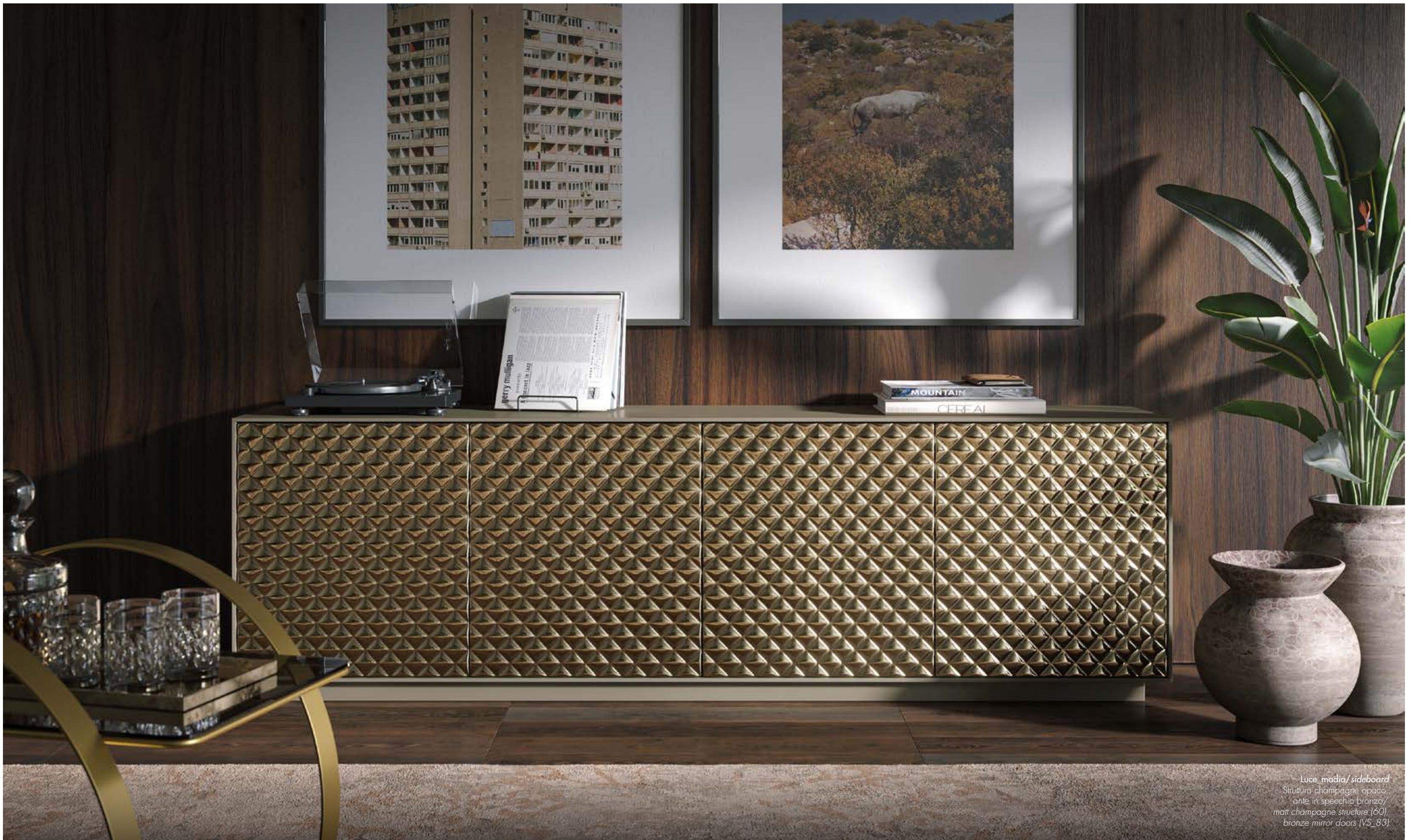

Luce_madia/sideboard
Struttura champagne opaco,
ante in specchio bronzo/
matt champagne structure (60),
bronze mirror doors (VS_83)

monolite emperador

Massimo Mottin | Ernesto Barbieri

Madia contenitore a quattro ante completamente rivestita esternamente con pellicola di riproduzione marmorea Emperador 100 gloss, applicata con tecnologia post-forming.

Four-door storage unit, completely covered on the outside with a 100 gloss Emperador marble reproduction film, applied using the post-forming technique.

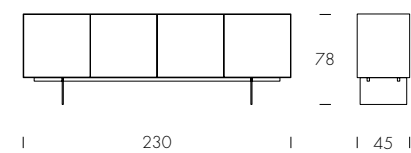

Monolite emperador_madia/sideboard
base verniciato bronzo pietra,
struttura e frontali riproduzione marmorea applicata Emperador/
Stone bronze powder coated base (83),
Emperador marble effect applied structure and doors



Monolite emperador_madia/sideboard
base verniciato bronzo pietra,
struttura e frontali riproduzione marmorea applicata Emperador/
Stone bronze powder coated base (83),
Emperador marble effect applied structure and doors

Altri elementi: specchio Pitti/
Other items: Pitti Mirror

off

Massimo Mottin | Ernesto Barbieri

Grazie alla combinazione di legno laccato e vetro, la madia Off conferisce all'ambiente luminosità ed eleganza; il vetro a specchio crea un gioco di luci e riflessi che esaltano la preziosità del materiale e delle lavorazioni.

Thanks to the combination of lacquered wood and glass, the Off sideboard gives the room brightness and elegance; the mirror glass creates a play of light and reflections that enhance the preciousness of the material and workmanship.

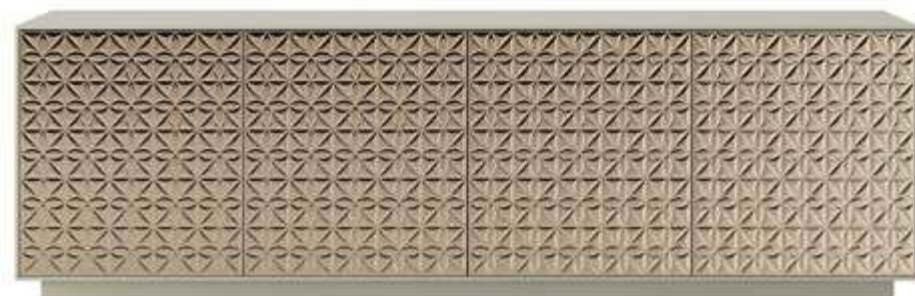
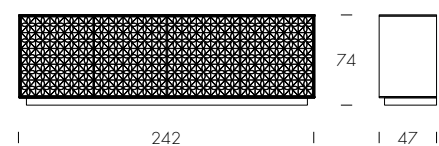

Off_madia/sideboard
struttura laccato champagne opaco, frontali in specchio bronzo/
matt champagne lacquered structure (60), bronze mirror (V_184) doors

Altri elementi:
vaso e centrotavola Futurism/
Other items:
Futurism vase and centrepiece



Off_madia/sideboard
 struttura laccato champagne opaco, frontali in specchio bronzo/
 matt champagne lacquered structure (60), bronze mirror (V_184) doors.

Altri elementi:
 poltrona Mama, tavolino Remind, vaso e centrotavola Futurism/
 Other items:
 Mama armchair, Remind coffee table, Futurism vase and centerpiece

patsy

Massimo Mottin | Ernesto Barbieri

Patsy è un'elegante madia in legno laccato, caratterizzata da fresature orizzontali che si ripetono su fianchi ed ante. Il top è disponibile anche in specchio bronzato.

Patsy is an elegant lacquered wood sideboard, characterized by horizontal millings that are repeated on the sides and doors. The top is also available in bronzed mirror.

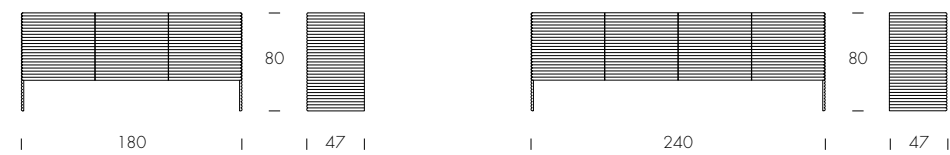

Patsy_madia/sideboard
struttura laccato fango opaco/
matt mud lacquered structure (51)

Altri elementi: specchio Eden, lampade Lanterna, tavolini Iddu/
Other items: Eden mirror, Lanterna lamps, Iddu coffee tables

patsy élite

Massimo Mottin | Ernesto Barbieri

Patsy Élite è un'elegante madia in legno laccato, caratterizzata da fessure orizzontali che si ripetono su fianchi ed ante. Il top è disponibile anche in specchio bronzato.

Patsy Élite is an elegant lacquered wood sideboard, characterized by horizontal millings that are repeated on the sides and doors. The top is also available in bronzed mirror.

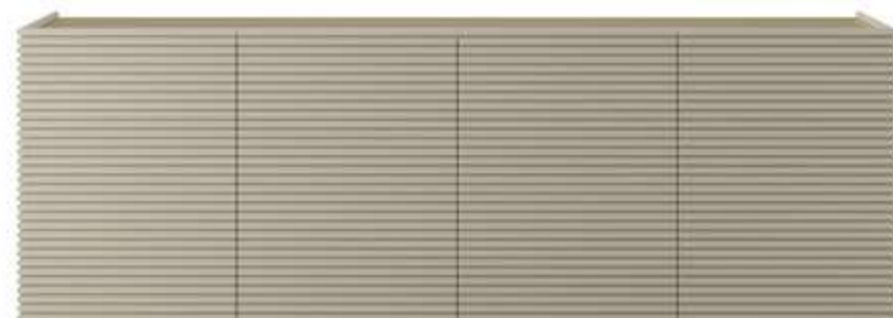
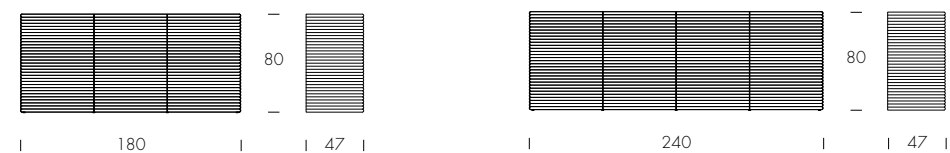

Patsy Élite_madia/ sideboard
struttura laccato beige opaco, top in specchio bronzo/
matt beige lacquered structure (36), top in bronze mirror (V_184)



Patsy Élite_madia/sideboard
 struttura laccato beige opaco, top in specchio bronzo/
 matt beige lacquered structure (36), top in bronze mirror (V_184)

Altri elementi: specchi Arké, tappeto Gea, tavolini Giudecca/
 Other items: Arké mirrors, Gea rug, Giudecca coffee tables

saffira

Luca Roccadadria

È una danza di riflessi e materia. Le ante in vetro a specchio della madia Saffira si curvano e si avvolgono l'una nell'altra, creando un movimento sinuoso che ricorda la trama di una treccia, un segno di continuità e fluidità. Ogni curva è un riflesso di luce che scorre lungo la superficie, dando vita a un gioco dinamico tra solidità e leggerezza.

It is a dance of reflections and matter. Saffira sideboard's mirror glass doors fold and wrap around each other, creating a sinuous movement reminiscent of the weave of a braid, a sign of continuity and fluidity. Each fold is a reflection of the light flowing along the surface, creating a dynamic interplay between solidity and lightness.

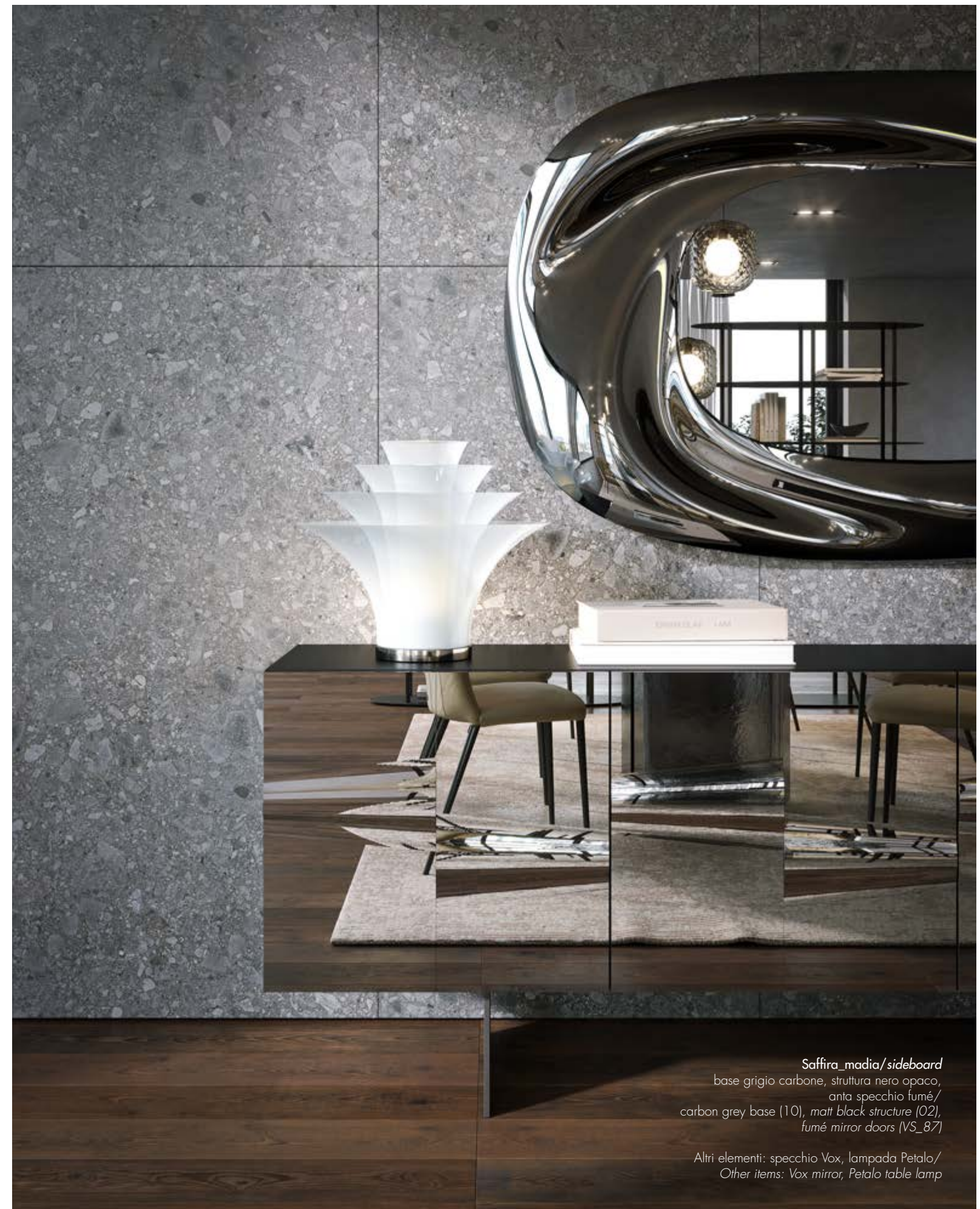
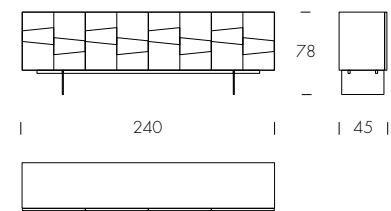

Saffira_madia/sideboard
base grigio carbone, struttura nero opaco,
anta specchio fumé/
carbon grey base (10), matt black structure (02),
fumé mirror doors (VS_87)

Altri elementi: specchio Vox, lampada Petalo/
Other items: Vox mirror, Petalo table lamp



Saffira_madia/sideboard
 base grigio carbone, struttura nero opaco,
 anta specchio fumé/
 carbon grey base (10), matt black structure (02),
 fumé mirror doors (VS_87)

Altri elementi: specchio Vox, lampada Petalo/
 Other items: Vox mirror, Petalo table lamp

selene

Roberto Semprini

Le ante a specchio della madia Selene catturano l'ambiente e moltiplicano lo spazio con giochi di riflessi in continuo movimento. Il motivo geometrico ad arco incide la superficie con eleganza, creando un ritmo visivo che richiama l'architettura classica, reinterpretata in chiave moderna.

The mirrored doors of Selene sideboard catch the space and multiply it with ever-changing plays of reflections. The arched geometric pattern engraves the surface with elegance, creating a visual rhythm reminiscent of classical architecture, reinterpreted in a modern key.

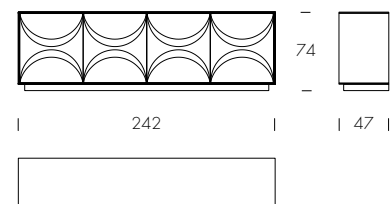

Selene_madia/sideboard
struttura champagne opaco, anta specchio bronzo/
matt champagne structure (60), bronze mirror doors (VS_83)



Selene_madia/ sideboard
struttura champagne opaco, anta specchio bronzo/
matt champagne structure (60), bronze mirror doors (VS_83)

Altri elementi: lampada Petalo/
Other items: Petalo table lamp

adone plissé

Luca Roccadadria | Ernesto Barbieri

Il basamento in vetro finemente lavorato con trama plissettata crea riverberi di luce che, insieme al top leggero in ceramica o al top in legno a sezione diamantata per la versione Silk Wood, rendono la consolle Adone Plissé un elemento d'arredo elegante e dinamico.

The finely crafted, pleated glass base, together with the light porcelain stoneware top or the diamond-cut wood top for the Silk Wood version, create an elegant and dynamic piece of furniture.

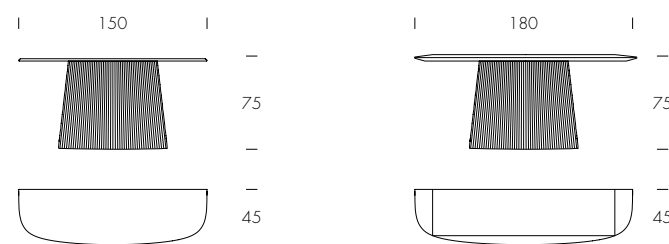

Adone Plissé_console/console
base specchio argento, top in frassino nero/
silver mirror base (V_45), black ash top (25)

arco

Angelo Tomaiuolo

La consolle Arco è caratterizzata da una leggera struttura curvata rivestita in legno e da un top incassato in gres. Perfetta per essere utilizzata come piano d'appoggio per oggetti decorativi o come base per una lampada, è abbinabile all'omonimo tavolo.

The Arco console features a light curved wood-covered frame and a stoneware recessed top. Perfect for use as a tabletop for decorative objects or as a base for a lamp, it can be combined with the table of the same name.

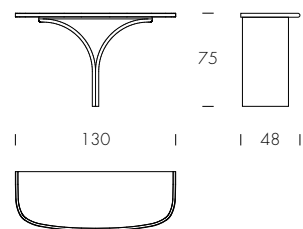

Arco_console/console
base noce canaletto, top in gres
porcellanato Macchiavvecchia lucido/
canaletto walnut base (14),
glossy Macchiavvecchia porcelain stoneware top (V_87P)

Altri elementi: specchio Galileo/
Other items: Galileo mirror

reverse

Massimo Mottin | Ernesto Barbieri

La consolle Reverse completa l'omonima famiglia di tavoli. L'iconica base in metallo verniciato sostiene un piano sagomato disponibile in innumerevoli varianti di gres porcellanato.

Reverse console completes the Reverse table family. The iconic powder coated metal base supports a shaped top available in various porcelain stoneware finishes.

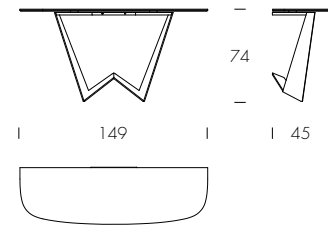

Reverse_console/console
base basalto opaco, top in gres
porcellanato Taj Mahal/
matte basalt base (87),
Taj Mahal porcelain stoneware top (V_61P)

Altri elementi: specchio Pitti, lampade Etoile/
Other items: Pitti mirror, Etoile lamps

afrodite

Luca Roccadadria

La cornice in vetro fuso si muove come onde sulla superficie, segni organici che sembrano catturare il movimento dell'acqua. È un oggetto mutevole, capace di adattarsi allo spazio e di dialogare con chi lo osserva. L'insero a mezzaluna taglia la geometria, permettendo di creare composizioni con due specchi.

The melted glass frame moves like waves on the surface, organic marks that seem to capture the movement of water. It is a mutable object, able to match the space and enter into a dialogue with the viewer. The half-moon insert cuts through the geometry, allowing the creation of compositions with two mirrors.

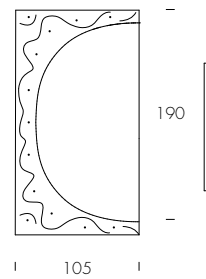

Afrodite specchio/mirror
struttura specchio fumé/
fumé mirror structure (VS_87)

Altri elementi: vetrina Venus/
Other items: Venus showcase



Afrodite_specchio/mirror
struttura specchio fumé/
fumé mirror structure (VS_87)

Altri elementi: vetrina Venus/
Other items: Venus showcase

afrodite maxi

Ernesto Barbieri

In questa versione, il cerchio completo al centro diventa un simbolo di armonia e totalità; la cornice in vetro fuso si muove come onde sulla superficie. Afrodite Maxi è presenza scenica, equilibrio tra materia e riflesso. Un oggetto che muta con la luce e con lo sguardo, capace di amplificare lo spazio, creando un senso di continuità fluida e avvolgente.

In this version, the complete circle at the centre becomes a symbol of harmony and wholeness, while the cast glass frame ripples across the surface like waves. Aphrodite Maxi has a strong stage presence, striking a balance between matter and reflection. It is an object that changes with the light and the gaze, capable of amplifying space by creating a sense of fluid, enveloping continuity.

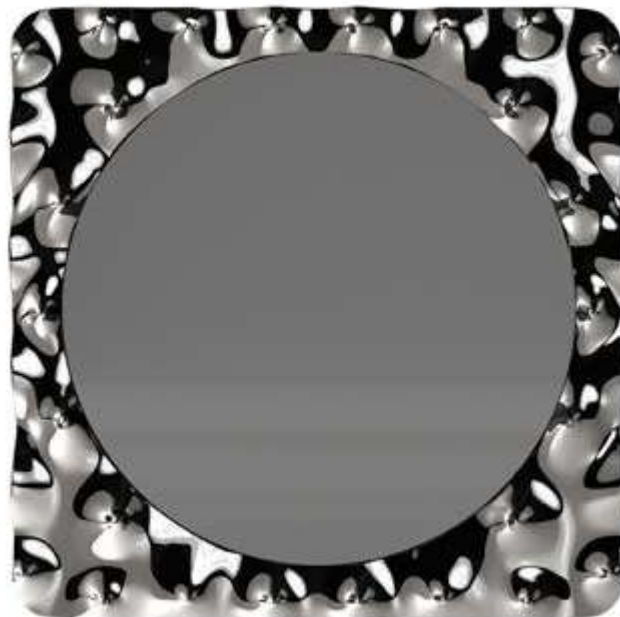
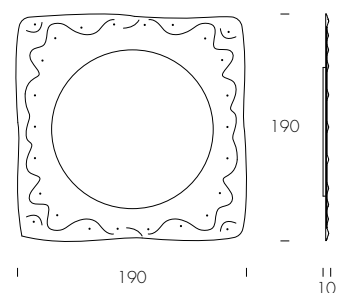

Afrodite Maxi_specchio/mirror
struttura specchio bronzo/
bronze mirror structure (VS_83)

Afrodite Maxi_specchio/mirror
struttura specchio bronzo/
bronze mirror structure (VS_83)

Altri elementi:
lampade Miss, lampade
Mood, madia Cristalia/
Other items:
Miss floor lamps, Mood ceiling
lamps, Cristalia sideboard



arké

Angelo Tomaiuolo

Il design moderno e raffinato della specchiera da parete Arké, con inserto laterale in vetro stampato, offre personalità e stile all'ambiente, oltre che donare luce ed allargare otticamente gli spazi.

The modern and refined design of the Arké wall mirror, with printed glass side insert, offers personality and style to the room, as well as giving light and optically enlarging the space.

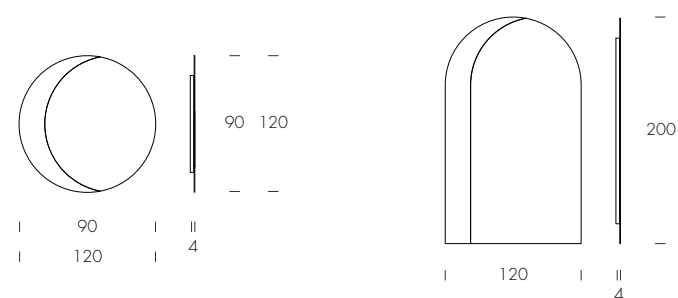

Arké specchio/mirror
specchio argento, inserto stampa Crystal Calacatta/
silver mirror (V_45), Crystal Calacatta digital print (ST02)

Altri elementi: tavolino Giudecca, appendiabiti Libellula/
Other items: Giudecca coffee table, Libellula coathanger

eden

Luca Roccadadria

Il gioco di riflessi delle forme curve caratterizzano l'elegante sagoma dello specchio Eden, disponibile in due diverse forme e tre dimensioni, nelle finiture bronzo e fumé.

Available in three sizes, two different shapes and finishes - bronze and fumé - , the elegant outline of the Eden mirror is characterised by a play of reflections and curved shapes.

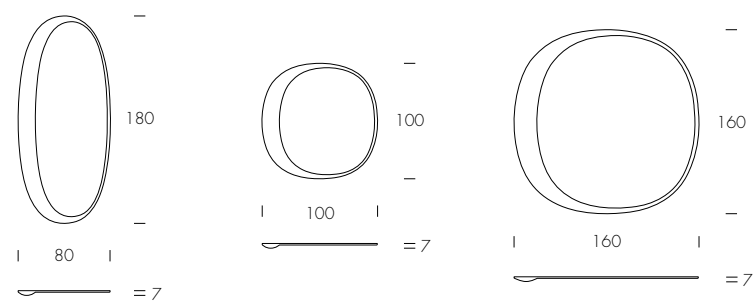

Eden_specchio/mirror
specchio fumé/
fumé mirror (VS_87)



Eden_specchio/mirror
specchio bronzo/
bronze mirror (V_184)

Altri elementi: lampade Lanterna/
Other items: Lanterna lamps

eos

Luca Roccadadria

Uno specchio che unisce arte e design, caratterizzato da una cornice in vetro fuso dalle superfici mosse, che crea un raffinato contrasto con il vetro specchiato centrale. Le due forme interagiscono armoniosamente, completandosi a vicenda per dar vita a un oggetto dalle proporzioni visive perfette, capace di valorizzare qualsiasi ambiente. Le geometrie, tra fluidità e rigore, instaurano un dialogo visivo in cui ogni linea trova il suo equilibrio nell'insieme.

A mirror that combines art and design, characterised by a fused glass frame with undulating surfaces that contrast with the central mirrored glass. The two forms interact harmoniously, complementing each other to create an object with perfect visual proportions, capable of enhancing any environment. The geometries, between fluidity and rigour, create a visual dialogue in which each line finds its balance within the whole.

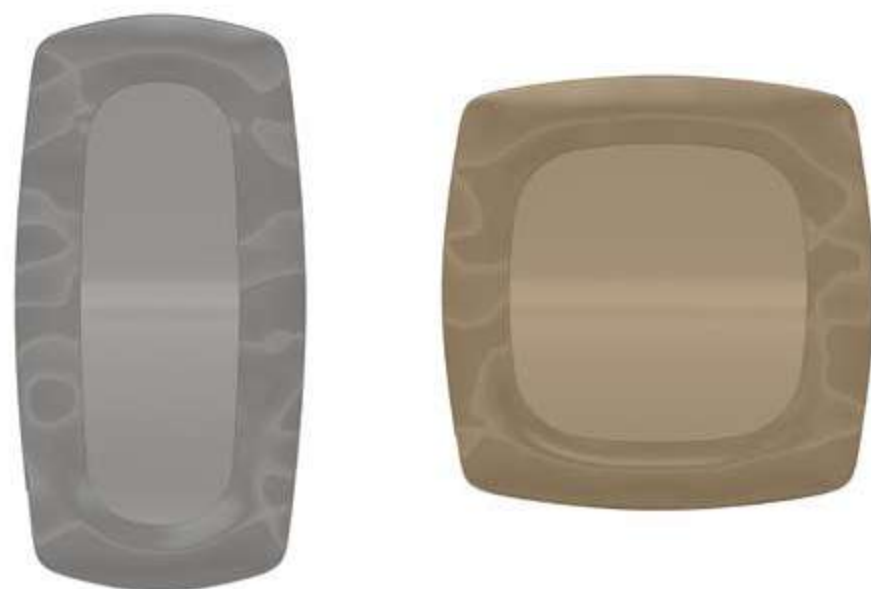
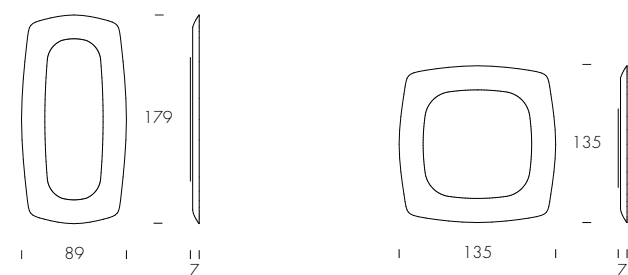

Eos_specchio/mirror
specchio fumé/tumé mirror (VS_87)

Altri elementi/Other items:
tavolini Dot/Dot coffee tables





Eos_specchio/mirror
specchio bronzo/
bronze mirror (V_184)

galileo

Luca Roccadadria | Ernesto Barbieri

Galileo è una specchiera curvata con stampa digitale e specchio centrale che, grazie al suo particolare design, può essere il punto focale di qualsiasi ambiente.

Galileo is a curved mirror with a digital print and a central mirror that, thanks to its special design, can be the focal point of any room.

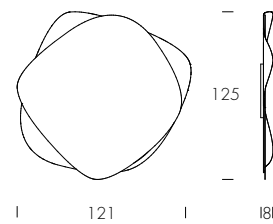

Galileo_specchio/mirror
specchio bronzo, inserto stampa Crystal Calacatta/
bronze mirror (V_184), Crystal Calacatta digital print (ST02)



pitti

Ernesto Barbieri

Specchio tondo, quadrato o rettangolare con cornice in fusione goccia: con le sue delicate linee dai motivi geometrici, Pitti dona un fascino raffinato ad ogni tipo di spazio living.

Round, square or rectangular mirror with a droplet cast frame: with its delicate lines with geometric patterns, Pitti gives refined charm to any type of living space.

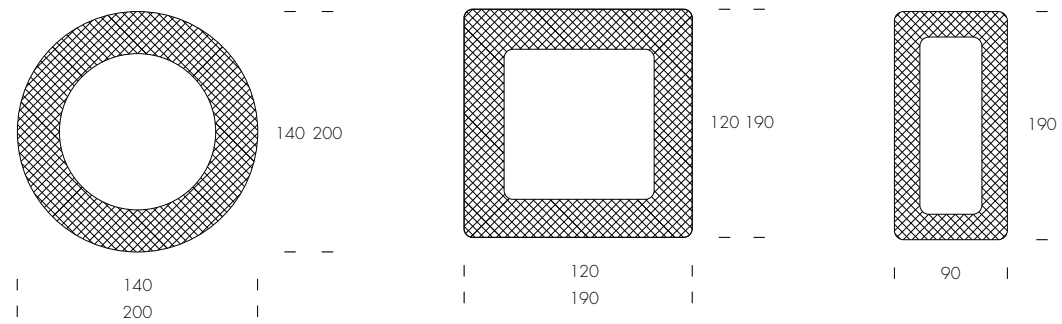

Pitti_specchio/mirror
specchio bronzo/bronze mirror (V_184)

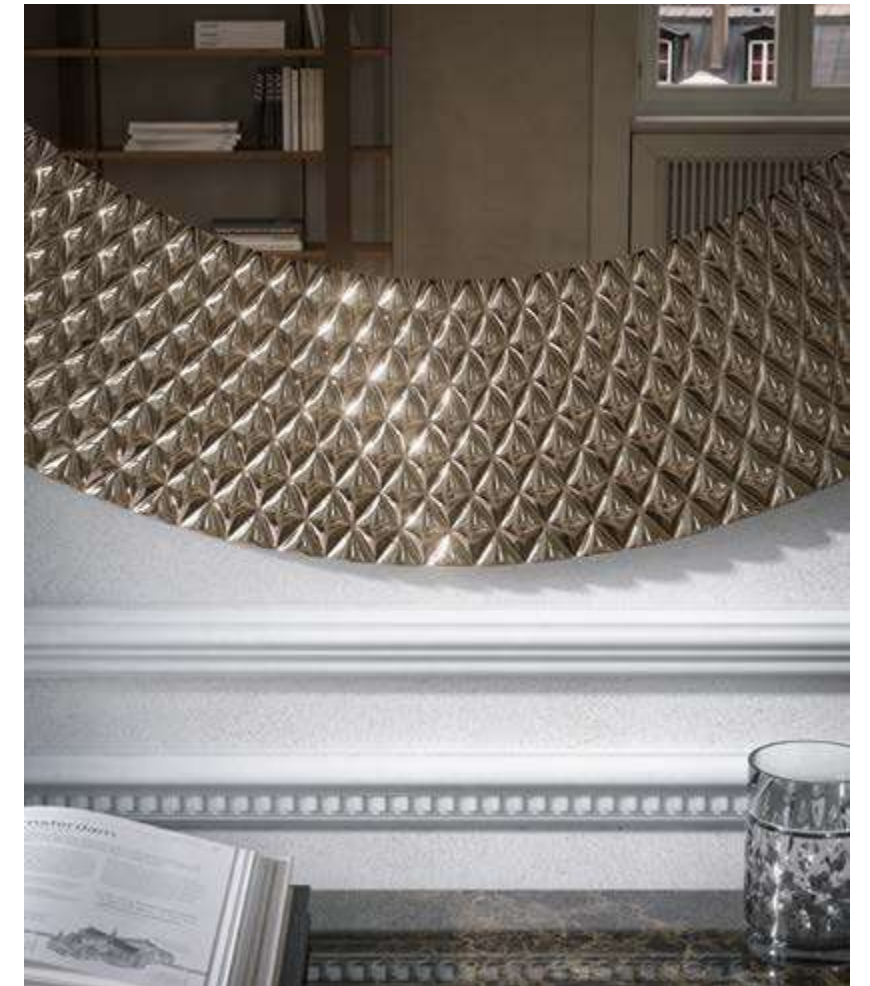

Pitti_specchio/mirror
specchio bronzo/bronze mirror (V_184)

VOX

Studio GBS

Vox è uno specchio dalla forte personalità, un complemento d'arredo che si distingue per la sua cornice scolpita da delicate increspature, che si rincorrono in un vortice di morbidi riflessi. Ogni curva cattura e diffonde la luce con eleganza, dando vita a un gioco di luci e riflessi che avvolge lo specchio centrale.

Vox is a mirror with a strong identity, a furnishing accessory that stands out for its frame sculpted by delicate waves that chase each other in a swirl of soft reflections. Each curve delicately captures and diffuses the light, creating a play of light and reflections that envelops the central mirror.

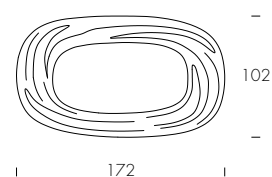

Vox_specchio/mirror
struttura specchio fumé/
fumé mirror structure (VS_87)

arturo artistic glass

Luca Roccadadria | Ernesto Barbieri

Ottenuti da un unico pezzo di vetro curvato, questi complementi d'arredo si trasformano in vere e proprie opere scultoree, esaltate dalle esclusive finiture Calacatta e Calacatta Black. Un inno alla raffinatezza che regala una sensazione di lusso discreto e moderno.

Made from a single piece of moulded glass, these coffee tables become true sculptural pieces, enhanced by the exclusive Calacatta and Calacatta Black finishes. An ode to refinement that conveys a sense of discreet, modern luxury.

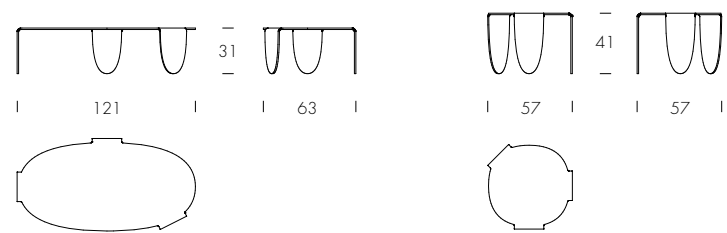

Arturo artistic glass_tavolini/ coffee tables
strutture in vetro stampato
Crystal Calacatta e Calacatta Black/
Crystal Calacatta (ST02) and Black Calacatta (ST03)
printed glass structures



Arturo artistic glass_tavolini/coffee tables
strutture in vetro stampato
Crystal Calacatta ea Calacatta Black/
Crystal Calacatta (ST02) and Black Calacatta (ST03)
printed glass structures.

Altri elementi: divano Domus/
Other items: Domus sofa

atollo

Andrea Andretta Studio

Coppia di tavolini in vetro verniciato. Realizzati con materiali di alta qualità, i tavolini Atollo si caratterizzano per la particolare superficie martellata disponibile in verde acqua, ambra e fumé. La superficie lucida del vetro riflette la luce ambientale, amplificandola e creando un'atmosfera luminosa e accogliente.

Pair of coffee tables in lacquered glass. Made from high quality materials, the Atollo coffee tables feature a special hammered finish, available in water green, amber and fumé. The polished surface of the glass reflects and amplifies ambient light, creating a bright and welcoming atmosphere.

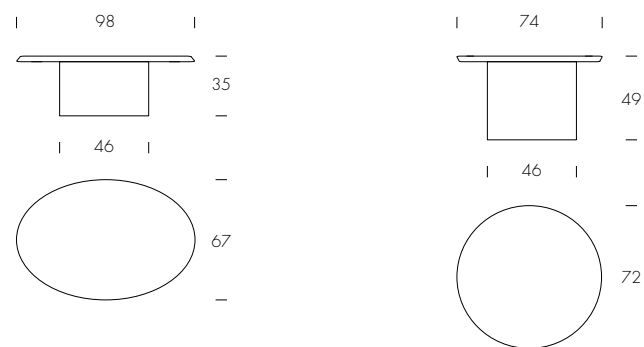

Atollo_tavolini/coffee tables
vetro verde acqua e vetro fumé/
water green (MVO1) and fumé (MVO3) glass



Atollo tavolini/coffee tables
vetro verde acqua e vetro fumé/
water green (MV01) and fumé (MV03) glass

giudecca

Massimo Mottin | Ernesto Barbieri

Dall'aspetto leggero e delicato, i tavolini Giudecca sono complementi d'arredo in vetro soffiato artistico veneziano, ideali per uno stile moderno ed elegante; disponibili in colorazione ambra e fumé, sono declinabili sia come tavolini che come servetti. Il vetro colorato rende possibili innumerevoli giochi di luce grazie a trasparenze e riflessi. Il basamento è in legno laccato nero opaco.

With a light and delicate design, Giudecca side tables in venice artistic blown glass are ideal furnishing complements for a modern and elegant style; available in amber and fumé glass, they can be declined both as side tables and as servants. The colored glass makes possible countless plays of light thanks to transparencies and reflections. The base is in matt black lacquered wood.

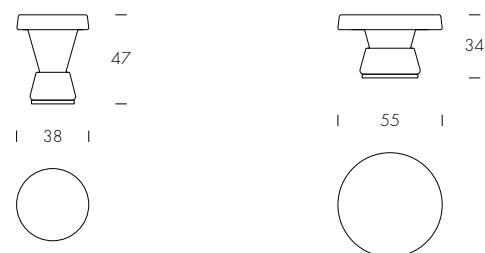

Giudecca_tavolini/coffee tables
vetro ambra e vetro fumé/
amber (V_55) and fumé (V_85) glass

Altri elementi: poltrone Mama/
Other items: Mama armchairs

iddu

Massimo Mottin | Ernesto Barbieri

Dallo stile lineare ed essenziale, i tavolini Iddu sono costituiti da due forme semplici sovrapposte: la base a tronco di cono in metallo verniciato a supporto del vassoio tondo in finitura. Il piano può essere impreziosito con dei top opzionali ad incasso in gres.

Linear and essential in style, Iddu coffee tables are made of two simple shapes placed one on top of the other: the truncated cone base in powder-coated metal, supports the round tray in the same finish. The top can be enhanced with optional recessed stoneware tops.

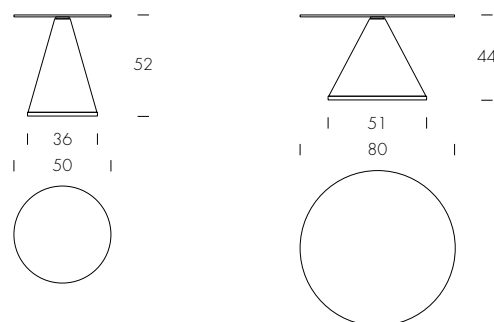

Iddu_tavolini/coffee tables
struttura grigio carbone, top in gres
Alaska White e gres Orobico Chic/
Carbon grey structure (10), Alaska White (V_17P)
and Orobico Chic (V_18P) porcelain stoneware



Iddu_tavolini/coffee tables
 struttura bronzo pietra e grigio carbone,
 top in gres Alaska White e gres Orobico Chic/
 Stone bronze (83) and carbon grey (10) structure,
 Alaska White (V_17P) and Orobico Chic (V_18P) porcelain stoneware

Altri elementi: divano Montecarlo, tappeto Pixel/
 Other items: Montecarlo sofa, Pixel rug

konca

Massimo Mottin | Ernesto Barbieri

Konca è un tavolino dalle forme morbide, realizzato in vetro soffiato artistico veneziano; il piano riproduce l'effetto delle increspature dell'acqua. Disponibile in due dimensioni e due colorazioni differenti (verde pavone e ambra) per creare il perfetto mix adattabile ad ogni contesto domestico. Il basamento è in legno laccato nero opaco.

Konca is a softly shaped coffee table made of artistic venetian blown glass; the top reminds of water ripples effect. Available in two different sizes and colors - peacock green and amber - to create the perfect mix adaptable to any home setting. The base is in matt black lacquered wood.

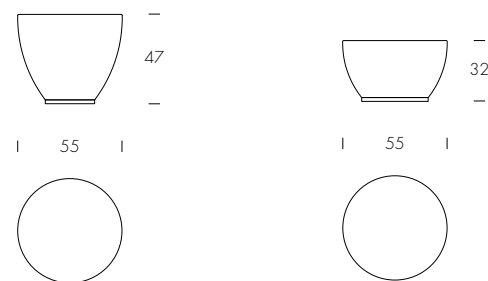

Konca tavolini / coffee tables
vetro verde pavone e ambra /
peacock green (V. 57) and amber (V. 55) glass

soffio

Massimo Mottin | Ernesto Barbieri

Soffio è una coppia di tavolini in vetro soffiato artistico veneziano plissettato in due varianti di colore, verde oliva e fumé, con base in legno laccato nero opaco.

Soffio is a pair of Venetian blown glass coffee tables in two different colors - olive green and fumé - with a matt black lacquered wooden base.

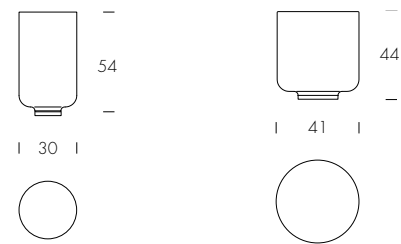

Soffio_tavolini/coffee tables
vetro verde oliva e fumé/
olive green (V_15) and fumé (V_85) glass

soffio élite

Massimo Mottin | Ernesto Barbieri

Tavolini in vetro soffiato artistico veneziano, con effetto plissettato sulla superficie, in due varianti di colore, verde oliva e fumé; arricchiti da eleganti top rotondi con bordo inclinato, rivestiti in frassino spazzolato o noce canaletto.

Coffee tables in venetian artistic blown glass in two different colors - olive green and fumé - with a pleated effect on the surface, enriched with elegant round tops with bevelled edges, covered with brushed ash or canaletto walnut.

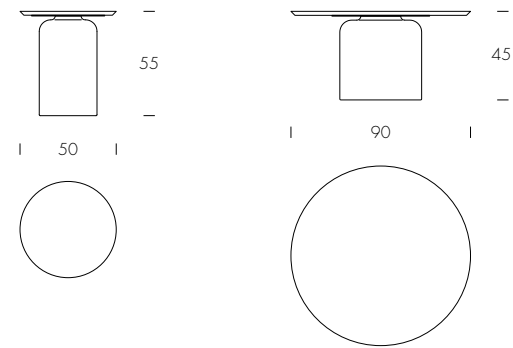

Soffio Élite tavolini/coffee tables
vetro verde oliva e top frassino nero,
vetro fumé e top noce canaletto/
olive green (V_15) glass and black ash top (25),
fumé (V_85) glass and canaletto walnut top (14)



Soffio Élite, tavolini/coffee tables
vetro verde oliva e top frassino nero,
vetro fumé e top noce canaletto/
olive green [V_15] glass and black ash top [25],
fumé [V_85] glass and canaletto walnut top [14]

Altri elementi:
poltrona Ricciolo, tappeto Pixel/
Other items:
Ricciolo armchair, Pixel rug

checker

Kazuko Okamoto

Libreria dalle forme geometriche, che trasmette un senso di dinamismo, rendendo lo spazio più divertente. Per rendere la struttura più solida, i pannelli laterali sono disposti in diagonale per conferire ritmo e la parte anteriore dei pannelli e dei ripiani è tagliata in diagonale per aggiungere ulteriore dinamicità. L'effetto è amplificato quando i pannelli vengono collegati tra loro. Visivamente la struttura si integra con gli oggetti posizionati su di essa.

A shelf with a simple structure but with a sense of dynamism that would add fun to the space. To make the structure stronger, the side panels are arranged diagonally to add tempo, and the front of the side panels and shelves is cut diagonally to add rhythm; connecting them will expand more fun. The statement will complement the items placed.

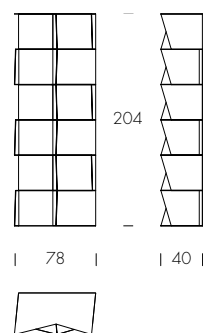

Checker_libreria/bookshelf
struttura in bronzo pietra/
stone bronze structure (83)



Checker libreria/bookshelf
struttura in bronzo pietra/
stone bronze structure (83)

Altri elementi: tavolini Atollo,
lampada Cortina, divano Domus/
Other items: Atollo coffee tables,
Cortina floor lamp, Domus sofa

oasi xl

Luca Roccadadria

Questa libreria realizzata in lamiera e tubo di metallo nasce dall'immagine di sassi smussati dalla natura, che si adagiano su una struttura in metallo essenziale, quasi invisibile. Un equilibrio tra leggerezza e forza, tra geometria e casualità organica, per dare vita a un elemento non solo funzionale, ma che racconta una storia di natura e design.

This bookcase in sheet metal and tubular metal was born from the image of stones smoothed by nature, resting on an essential, almost invisible metal structure. A balance between lightness and strength, between geometry and organic randomness, to create an element that is not only functional but also tells a story of nature and design.

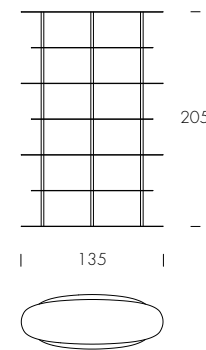

Oasi XL libreria/bookshelf
struttura bronzo pietra/
stone bronze structure (83)



Oasi XL libreria/bookshelf
struttura bronzo pietra/
stone bronze structure (83)

Altri elementi: tavolino Arturo artistic glass, divano Domus/
Other items: Arturo artistic glass coffee table, Domus sofa

agata lounge

Tonin Casa Creatives

Concepita con un imbottito più largo e accogliente, Agata Lounge riprende l'eleganza e il linguaggio formale delle sedute della stessa collezione, reinterpretandoli in chiave lounge. La struttura in metallo, sottile ma solida, conferisce leggerezza visiva e un tocco contemporaneo di design, rendendola perfetta per ambienti contract e residenziali dallo stile ricercato.

With its wider, more welcoming padding, Agata Lounge reinterprets the elegance and formal language of the Agata collection chairs in a lounge version. Slim yet sturdy metal structure add a touch of contemporary lightness to the design, making it ideal for refined contract and residential spaces alike.

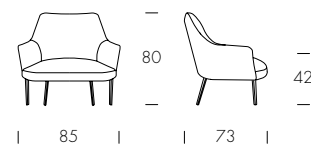

Agata Lounge_poltrona/armchair
struttura grigio carbone, rivestimento in pelle Nero/
carbon grey structure (10), Black leather upholstery (P_2)



Agata Lounge poltrona/armchair
struttura grigio carbone,
rivestimento in pelle fiore Giallo,
rivestimento in pelle Nero/
carbon grey struttura (10),
Yellow Grain leather upholstery (PF_4),
Black leather upholstery (P_2)

Altri elementi:
tavolini Atollo, tavolini Dot, tappeto Gea,
lampada da terra Iperbolle/
Other items:
Atollo coffee tables, Dot coffee tables,
Gea rug, Iperbolle floor lamp

domus

Borgonovo + Valsecchi

Domus incarna nella propria essenza di divano modulare il concetto di versatilità. Si pone al servizio dello spazio che lo circonda, configurandosi come un'isola silenziosa e confortevole, un'architettura di volumi in costante relazione con ciò che accade intorno. I suoi schienali si ispirano per forma e concetto ad una tradizionale merenda giapponese (onigiri), espressione iconica di semplicità, che riproposta sulla scala dell'abitare contemporaneo genera un microcosmo dove vivere ed esprimere i propri gesti quotidiani in uno spazio che si fa al tempo intimo e di relazione.

As a modular sofa, Domus embodies the concept of versatility. It places itself at the service of the space around it, configuring itself as a quiet and comfortable island, an architecture of volumes in constant relationship with what is happening around it. Its backs are inspired by the shape and concept of a traditional Japanese snack (onigiri), an iconic expression of simplicity that, re-proposed on the scale of contemporary living, creates a microcosm in which to live and express daily gestures in a space that becomes both intimate and relational.

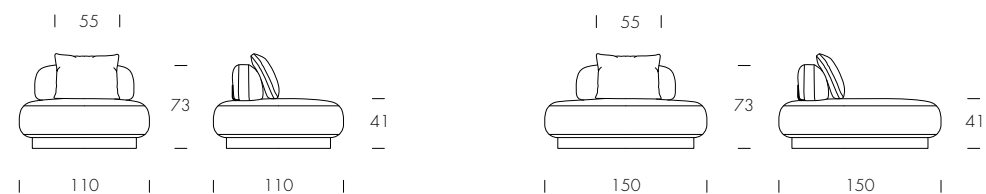

Domus_divano/sofa

base e inserto schienale in noce canaletto, rivestimento in tessuto Kimono Beige, cuscini in tessuto Kimono Grigio Gabbiano/
base and back insert in canaletto walnut (14), Beige Kimono fabric upholstery (KM401), back cushions in Gull grey Kimono fabric (KM601)

Altri elementi: tavolini Atollo, tappeto Raku,
porta tv Clyde, lampada Odissea/
Other items: Atollo coffee tables, Raku rug,
Clyde tv stand, Odissea floor lamp

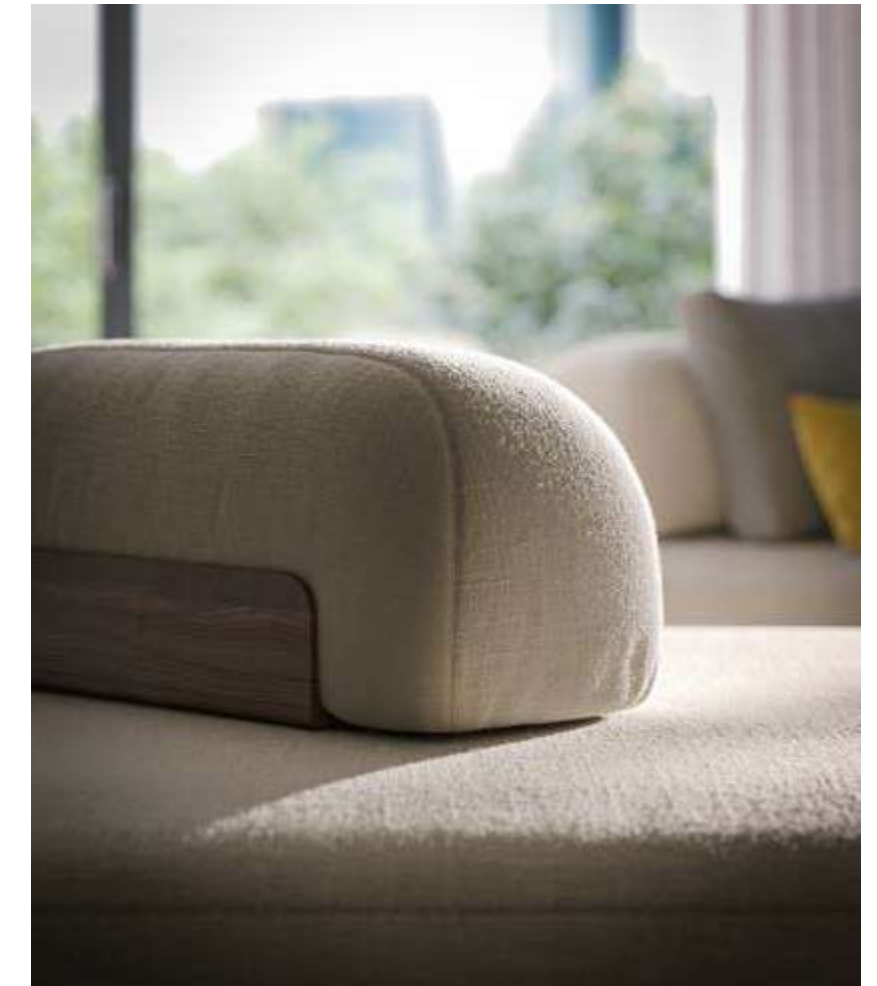

Domus_divano/sofa

base e inserto schienale in noce canaletto, rivestimento in tessuto Kimono Beige,
cuscini in tessuto Kimono Grigio Gabbiano/
base and back insert in canaletto walnut (14), Beige Kimono fabric upholstery (KM401),
back cushions in Gull grey Kimono fabric (KM601)

Altri elementi: tavolini Atollo, tappeto Raku,
porta tv Clyde, lampada Odissea, libreria Checker/
Other items: Atollo coffee tables, Raku rug,
Clyde tv stand, Odissea floor lamp, Checker bookshelf



montecarlo

Maurizio Varsi

Montecarlo è un divano componibile, rivestito in tessuto o pelle, che si adatta ad ogni living dallo stile moderno, aggiungendo un tocco di dinamismo grazie alle linee inclinate della base.

Montecarlo is a modular sofa, upholstered in fabric or leather, that fits into any living room with a modern style, adding a touch of dynamism thanks to the sloping lines of the base.

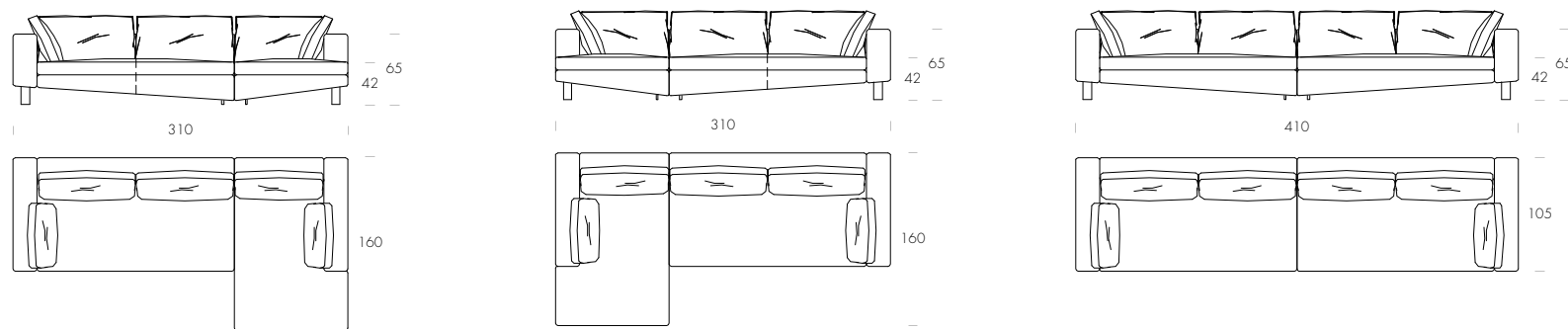

Montecarlo divano/sofa
rivestimento in tessuto Kimono verde Lichene,
base in metallo bronzo pietra/
Lichen green (KM409) Kimono fabric upholstery,
stone bronze (S83) base

Altri elementi: tavolini Dot
Other items: Dot coffee tables



Montecarlo divano/sofa
rivestimento in tessuto Bouclé bianco avana,
base in metallo bronzo pietra/
White avana (TB908) Bouclé fabric upholstery,
stone bronze (83) base

Altri elementi: tavolini Soffio Élite, specchio Pitti, lampade Venice Moon/
Other items: Soffio Élite coffee tables, Pitti mirror, Venice Moon lamps

aliente

Maurizio Varsi

Realizzato con materiali di alta qualità e design ergonomico, questo letto è perfetto per chi cerca comfort e stile contemporaneo. Caratterizzato dalla testiera formata da cuscini strutturali, presenta anche una pratica mensola in legno massello che permette di tenere a portata di mano libri, sveglie o qualsiasi altro oggetto.

Made of high-quality materials and ergonomic design, this bed is perfect for those seeking comfort and contemporary style. Featuring a headboard formed of structural pillows, it also has a practical shelf in solid wood that allows to keep books, alarm clocks or any other items within easy reach.

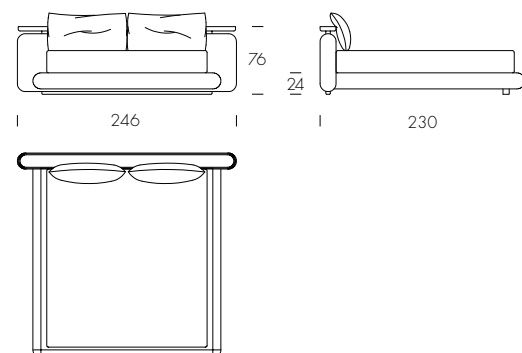

Aliante letto/bed
rivestimento in tessuto Bouclé bianco avana,
mensola in frassino nero/
White avana (TB908) Bouclé fabric upholstery,
black ash (25) shelf

Altri elementi:
tavolini Cora, lampada Andromeda/
Other items:
Cora coffee tables, Andromeda lamps



Aliante_letto/bed
 rivestimento in tessuto Bouclé bianco avana,
 mensola in frassino nero/
 White avana (TB908) Bouclé fabric upholstery,
 black ash (25) shelf

Altri elementi:
 tavolini Cora, lampada Andromeda/
 Other items:
 Cora coffee tables, Andromeda lamps

bull

Andrea Lucatello

Il letto matrimoniale Bull, interamente foderato in morbida pelle, è un'icona di design contemporaneo dal carattere deciso e audace, grazie alle sue forme scultoree. Il giroletto e la testiera sembrano fondersi in un morbido e caldo abbraccio, dando vita ad un elemento d'arredo in cui sapienti lavorazioni e scelta dei materiali, raggiungono una sintesi perfetta.

Bull double bed, fully upholstered in soft leather, is an icon of contemporary design with a bold and decisive character, thanks to its sculptural forms. The bed frame and headboard seem to merge into a soft and warm embrace, creating a piece of furniture in which skilful workmanship and choice of materials achieve a perfect synthesis.

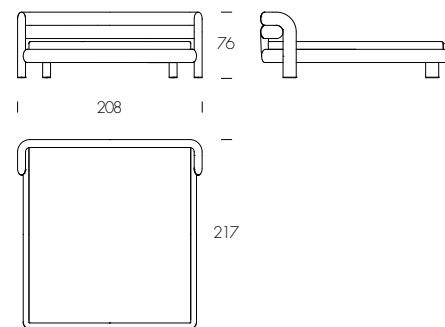

Bull_letto/bed
rivestimento in pelle Grigio Gabbiano/
Gull grey leather upholstery (P_29)



Bull letto/bed
rivestimenti in pelle Grigio Gabbiano/
Gull grey leather upholstery (P_29)

Altri elementi:
comodini Patsy, tappeto Raku, poltrona
Agata Lounge, lampade Klimt/
Other items:
Patsy night stand, Raku rug,
Agata Lounge armchair, Klimt lamps

cristalia night

Mattimo Mottin | Ernesto Barbieri

I comò e i comodini della collezione Cristalia riprendono l'eleganza della madia omonima, con superfici in vetro stampato Crystal Calacatta o Calacatta Black, dove la trama delle venature si intreccia alla luce, creando profondità e raffinatezza. Il basamento in metallo verniciato dona leggerezza e slancio. Una collezione che porta nella zona notte la bellezza senza tempo del Calacatta e la purezza del design contemporaneo.

The dressers and nightstands of the Cristalia collection echo the elegance of the namesake sideboard, featuring printed glass surfaces in Crystal Calacatta or Calacatta Black finish, where the vein texture interplays with the light to create depth and refinement. The powder coated metal base adds a sense of lightness and dynamism. A collection that brings the timeless beauty of Calacatta finish and the purity of contemporary design to the bedroom.

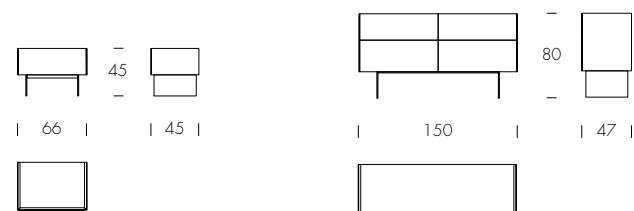

Cristalia_comodino/night stand
base bronzo pietra, struttura in vetro stampato
Crystal Calacatta, top in specchio bronzo/
stone bronze base (83), Crystal Calacatta
printed glass (ST02), bronze mirror top (V_184)

Altri elementi: lampada lanterna, letto Bull/
Other items: Lanterna table lamp, Bull bed



Cristalia_comò/dresser
base bronzo pietra, struttura in vetro stampato
Crystal Calacatta, top in specchio bronzo/
stone bronze base (83), Crystal Calacatta
printed glass (ST02), bronze mirror top (V_184)

Altri elementi: tavolini Soffio, specchio Arké/
Other items: Soffio coffee table, Arké mirror

patsy night

Massimo Mottin | Ernesto Barbieri

Il gruppo notte Patsy è caratterizzato da fresature orizzontali sulla superficie in legno laccato, che si ripetono su fianchi e ante, donando movimento e profondità alla materia. Il top in specchio aggiunge un tocco di luminosità a comò e comodini.

The Patsy night stand features horizontal milling on the lacquered wood surface, repeated on the sides and doors, giving movement and depth to the material. The mirrored top adds a touch of brightness to the chest of drawers and bedside tables.

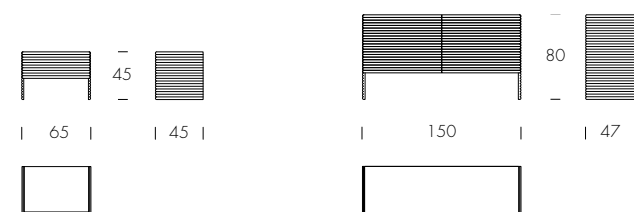

Patsy night_comodino/bedside table
struttura fango opaco, top in specchio bronzo/
matt mud structure (51), bronze mirror top (V_184)



Patsy night_comò/dresser
struttura fango opaco, top in specchio bronzo/
matt mud structure (51), top in bronze mirror (V_184)

Altri elementi: lampada Klimt/
Other items: Klimt lamp

andromeda

Tonin Casa Creatives

La lampada a sospensione Andromeda, con configurazioni da 3, 9 o 15 sfere ellittiche in vetro fumé, conferisce unicità volumetrica e dinamicità allo spazio che illumina.

Andromeda ceiling lamp, with configurations of 3, 9 or 15 fumé glass elliptical bulbs, adds volumetric uniqueness and dynamism to the space it illuminates.

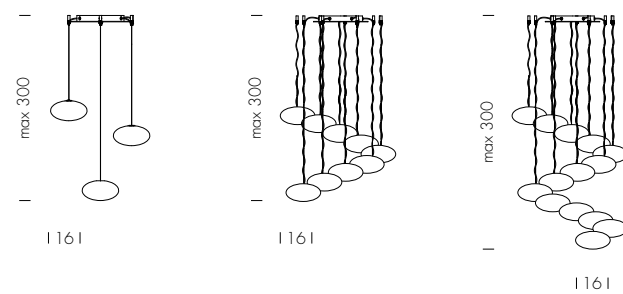

Andromeda_lampada/lamp
vetro fumé/
fumé glass (V_85)

cortina

Ernesto Barbieri

La lampada Cortina è costituita da tre steli in metallo verniciato che si slanciano con grazia, creando una silhouette che arricchisce ogni spazio con un tocco di sobria bellezza. La luce LED, discreta e avvolgente, si diffonde con delicatezza dal profilo sottile, creando atmosfere intime e accoglienti. Che sia in un angolo lettura, in soggiorno o nello studio, Cortina trasforma ogni ambiente in un luogo di bellezza silenziosa e luce perfetta.

Cortina lamp is made up of three powder coated metal stems that swing gracefully, creating a silhouette that adds a touch of quiet beauty to any space. The gentle and enveloping LED light diffuses delicately from the slender profile, creating an intimate and cosy atmosphere. Whether in a reading corner, living room or study, Cortina transforms any space into a place of calm beauty and perfect light.

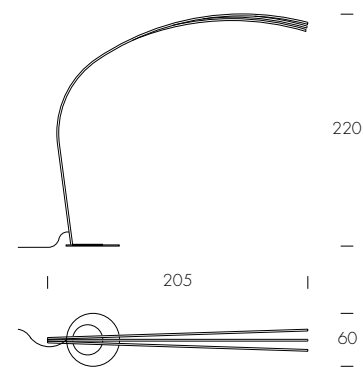

Cortina lampada/floor lamp
struttura in cromo nero/
black chrome structure

Altri elementi: tavolini Atollo,
tappeto Raku, divano Domus/
Other items: Atollo coffee tables,
Raku rug, Domus sofa



Cortina_lampada/floor lamp
struttura in cromo nero/
black chrome structure

Altri elementi: tavolini Atollo,
tappeto Raku, divano Domus/
Other items: Atollo coffee tables,
Raku rug, Domus sofa

iperbolle

Ernesto Barbieri

Iperbolle è una famiglia di lampade eleganti e leggere, caratterizzate da bolle che, grazie alla particolare lavorazione del vetro, diffondono e moltiplicano la luce in mille sfumature.

La piantana in metallo verniciato evoca uno stelo sottile a cui sono appese cinque bolle in vetro lavorato che sembrano fluttuare nell'aria, diffondendo una luce morbida e sofisticata.

Nella versione a sospensione, la struttura centrale in metallo cromato diventa una scultura luminosa: nove bracci si aprono come rami eleganti, ognuno impreziosito da due bolle di vetro.

Iperbolle is a family of elegant and delicate lamps characterised by spheres which diffuse and multiply the light in a thousand shades, thanks to the special processing of the glass.

The powder coated metal floor lamp has a slender stem from which hang five worked glass spheres that seem to float in the air, diffusing a soft and elegant light. In the ceiling version, the central chromed metal structure becomes a luminous sculpture: nine arms open like elegant branches, each decorated with two glass spheres.

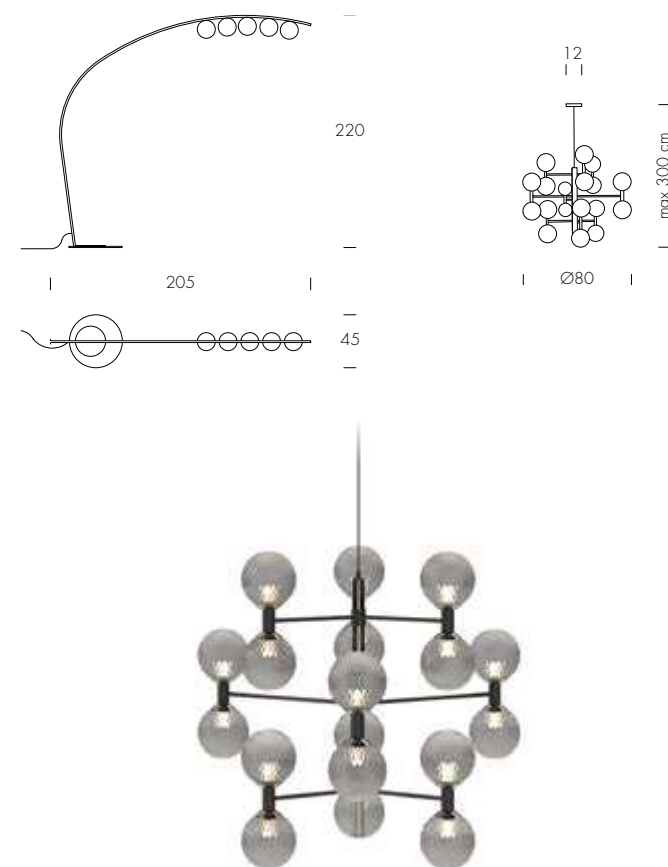

Iperbolle_lampada/floor lamp
struttura verniciato nero opaco,
sfere in vetro fumé/
black powder coated structure (02),
fumé glass spheres (V_85)

Altri elementi: tavolini Giudecca,
poltrona Agata Lounge/
Other items: Giudecca coffee tables,
Agata Lounge armchair



Iperbolle_lampada/ceiling lamp
struttura verniciato nero opaco,
sfere in vetro fumé/
black powder coated structure (02),
fumé glass spheres (V_85)

Lanterna

Ernesto Barbieri

La lampada Lanterna è caratterizzata dalla lavorazione tridimensionale a rombi del vetro soffiato artistico veneziano in finitura fumé; l'effetto trapezzato dà vita a giochi di luci e riflessi, rendendo l'ambiente sofisticato ed affascinante. Disponibile nella versione a sospensione o da tavolo.

Lantern lamp is characterised by the three-dimensional, rhomb-shaped venetian artistic blown glass in fumé finish; the quilted effect creates a play of light and reflections, making the environment sophisticated and fascinating. Available in ceiling and table versions.

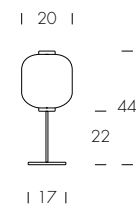
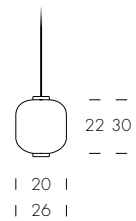

Lanterna_lampada da tavolo/table lamp
vetro fumé/
fumé glass (V_85)



Lantern_lampada a sospensione/ceiling lamp
vetro fumé, base cromata/
fumé glass (V_85), chromed base

mood

Tonin Casa Creatives

Le lampade sospese Mood, dal design raffinato e lineare, si ispirano nelle forme al volo degli uccelli. Le curve eleganti evocano la leggerezza del movimento, trasformando la luce in un'opera d'arte che unisce tradizione, innovazione e maestria artigianale, creando un'atmosfera di sofisticata eleganza.

Mood Ceiling Lights, with their refined and linear design, are inspired by the flight of birds. The elegant curves evoke the fluidity of movement, transforming light into a work of art that combines tradition, innovation and craftsmanship to create an atmosphere of refined elegance.

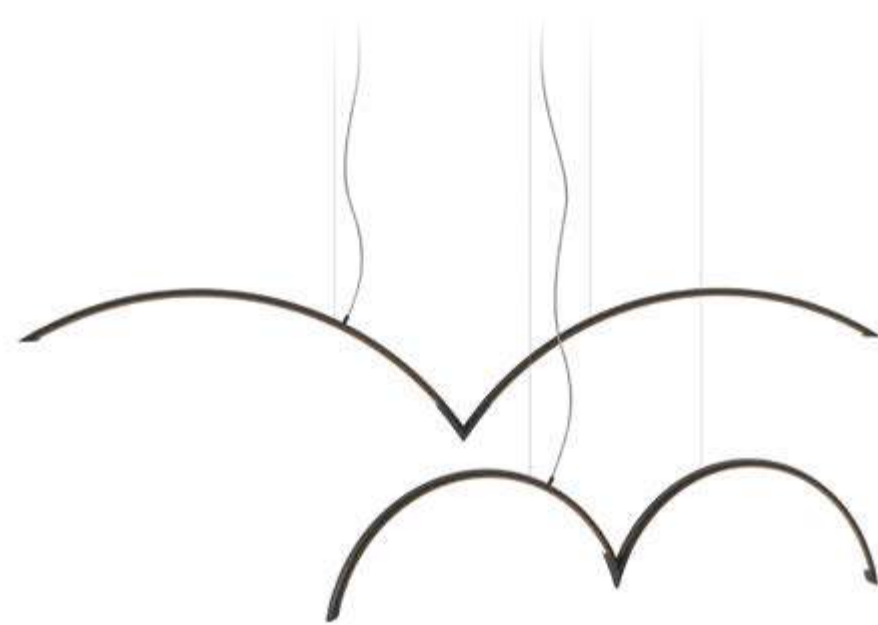
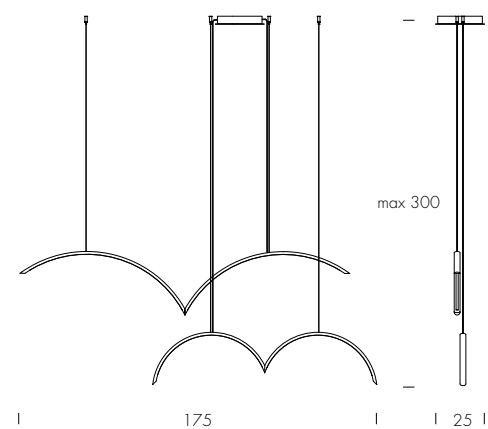

Mood_lampada/ceiling lamp
struttura verniciato nero opaco/
black powder coated structure (02)

petalo

Tonin Casa Creatives

Lampada da tavolo in vetro veneziano, lavorata a mano. La sua forma organica ricorda una fioritura; i suoi elementi inseriti in maniera concentrica, creano insieme alla luce effetti di trasparenze e sfumature, che danno origine ad un'atmosfera soffusa e rilassata.

Handmade Venetian glass table lamp. Its organic shape is suggested by a flower; its concentric elements create effects of transparency and shading with the light, creating a soft, relaxed atmosphere.

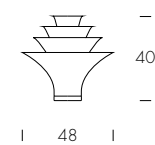

Petalo_lampada/lamp
vetro extrachiaro trasparente opalino/
opaline transparent extra-clear glass (48)

venice moon

Massimo Mottin | Ernesto Barbieri

Come a voler rievocare una luna luminosa che brilla sui canali veneziani, la lampada Venice Moon, con il suo vetro artistico veneziano soffiato bianco opalino o fumé, dona ad ogni ambiente un'atmosfera magica e sognante. Ogni esemplare è il simbolo di quella che è la creatività e l'artigianalità della tradizione veneziana.

Like a bright moon shining over the Venetian canals, the Venice Moon lamp, with its opaline white or fumé venetian artistic blown glass, creates a magical, dreamy atmosphere in any room. Each piece is a symbol of the creativity and craftsmanship of the Venetian tradition.

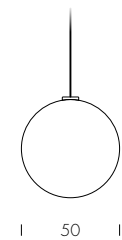

Venice Moon_lampada/lamp
vetro bianco opalino/
opaline white glass (48)



Venice Moon_lampada/lamp
vetro fumé/
fumé glass (V_8.5)

vaso soffio

Massimo Mottin | Ernesto Barbieri

I vasi Soffio, con la caratteristica struttura in vetro artistico veneziano soffiato e plissettato, disponibile in verde oliva e in fumé, vanno a completare la famiglia di tavolini omonimi.

The Soffio coffee table family is completed by the Soffio vases with their characteristic pleated venetian artistic blown glass structure, available in two different colors - olive green and fumé -.

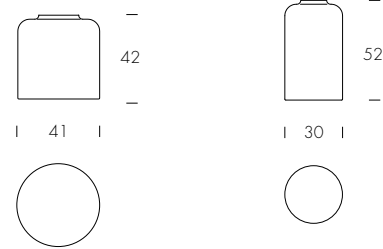

Soffio_vasi/vases
vetro fumé e verde oliva/
Fumé (V_85) and olive green (V_15) glass.

romeo

Tonin Casa Creatives

Il tritico di portafiori Romeo è formato da tre elementi a diverse altezze, pensati per creare composizioni dinamiche. La struttura minimalista è sospesa su sottili piedi in metallo verniciato e zincato rendendolo adatto all'utilizzo sia indoor che outdoor.

Romeo flower stand consists of three elements at different heights, designed to create dynamic compositions. The minimalist structure is supported by slim powder coated galvanized metal legs, making it suitable for both indoor and outdoor use.

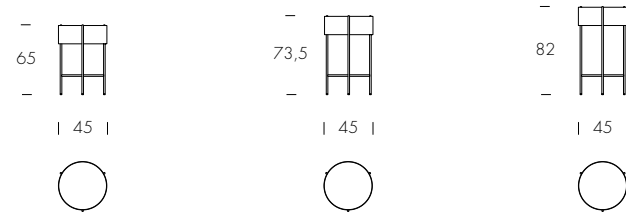

Romeo_porta fiori/flower stand
struttura bronzo pietra/
stone bronze structure (83)



Romeo_porta fiori/flower stand
struttura bronzo pietra/
stone bronze structure (83)

Altri elementi:
tavolino Atollo, tavolino Soffio, poltrone Agata
Lounge, libreria Oasi XL, tappeto Raku/
Other items:
Atollo coffee table, Soffio coffee table, Agata
Lounge armchairs, Oasi XL bookshelf, Raku rug

raku

Tonin Casa Creatives

Raku è un morbido tappeto dalla consistenza avvolgente; soffice al tatto, la sua eleganza si manifesta attraverso una delicata combinazione di colori. Le punte delle fibre, più chiare rispetto al fondo, si fondono armoniosamente creando sfumature leggere e raffinate.

Raku is a soft carpet with an enveloping texture; it is gentle to the touch and its elegance is revealed in a delicate combination of colours. The fibre tips, lighter than the background, blend harmoniously to create light and refined nuances.



mila

Tonin Casa Creatives

Realizzato pensando alla purezza e alla consistenza, il tappeto Rila presenta una fitta trama di lana pregiata, arricchita con poliestere per un tocco di lucentezza. Questa combinazione unica protegge dai segni dei punti di pressione dei mobili, sfruttando i benefici intrinseci della lana.

Crafted with purity and texture in mind, Rila rug features a dense weave of premium wool, subtly enriched with polyester for a touch of luster. This unique combination safeguards against pressure point marks from furniture, harnessing the inherent benefits of wool.

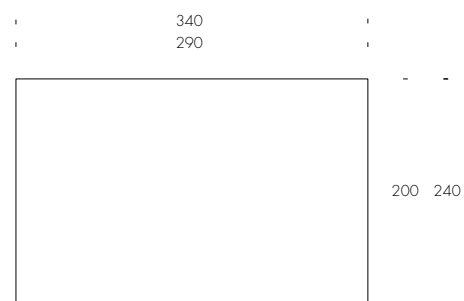

IT

Tonin Casa si riserva di apportare, senza preavviso, modifiche nei materiali, nei rivestimenti, nelle finiture e nei disegni dei prodotti presentati in questo catalogo. Le texture e i colori dei materiali e delle finiture hanno valore indicativo in quanto soggetti alle tolleranze dei processi di stampa.

È vietata ogni riproduzione totale e parziale in Italia e all'estero.

EN

Tonin Casa reserves the right to change, without previous notice, materials, covers, finishes and drawings of the products presented in this catalogue. The textures and colours of materials and finishes are indicative as they are depending on the tolerances of the printing process.

Total or partial reproduction of the products is prohibited in Italy and abroad.

RU

Tonin Casa оставляет за собой право, без каких-либо предупреждений, вносить изменения в используемые материалы, обивки, отделки и изображения продукции, представленной в данном каталоге.

Текстура и цвета материалов и отделок имеют ориентировочный характер, так как могут варьироваться в процессе печати.

ES

Tonin Casa se reserva el derecho de aportar modificaciones de dibujo, materiales, acabados y tapicerías, sin que esté obligada a dar aviso anticipado. Las texturas y los colores de los materiales y de los acabados tienen solo un valor indicativo porque están sujetos a la tolerancia en los procesos de imprenta.

Prohibida la reproducción total o parcial en Italia y en el extranjero.

FR

Tonin Casa se réserve le droit d'apporter, sans préavis, des modifications au niveau des matériaux, des revêtements, des finitions et du design des produits présentés dans ce catalogue. Les textures et les couleurs des matériaux et des finitions sont une valeurs indicative parce que ils changent selon la tolérance aux procédés d'imprimerie.

La reproduction, totale ou partielle, est interdite, que ce soit en Italie ou à l'étranger.

Style, graphic, 3D images:
Tonin Casa Mktg

Print:
CNI Compagnia Nazionale Italiana

Stampato in Italia Settembre 2025/Printed in Italy in September 2025

progetto
design



Tonin Casa is a brand of
Progetto Design International srl

via Guglielmo Marconi, 37
35010 San Pietro in Gu (PD), Italy

t +39 049 9453300
f +39 049 9450725

info@tonincasa.it
c.f. P.iva IT03817150240

COPYRIGHT © Progetto Design International srl
Tutti i diritti riservati - All rights reserved

