

HOME PHILOSOPHY
visionnaire

STARLIGHT

STARLIGHT

Orizzonte di novità, Starlight è la nuova capsule collection presentata da Visionnaire per definire un lifestyle metropolitano ed emozionale.

Sviluppata all'interno della maison, l'ispirazione che guida questa collezione è la natura nella sua traduzione organica e la ricerca di simboli universali. Il moon gate, nella sua accezione di "perfezione" ciclica e di apertura dello spazio abitativo verso il mondo naturale, il nido, simbolo di protezione e della vita che si rinnova. Forme curve ed avvolgenti definiscono una collezione dai volumi morbidi e dalle dimensioni contenute per appartamenti metropolitani, che rifugge da spigoli e sporgenze pronunciate, in favore di un'estetica organica e ricca di dettagli.

Starlight esprime la capacità di Visionnaire di realizzare progetti unici, espressione del proprio DNA, ma anche la capacità di assimilare simboli ed immagini dei paesi in cui opera per tradurli in oggetti dalla singolare identità. Starlight è una capsule che interessa tutti gli ambienti della casa, a partire dalle zone living fino alla definizione di nuovi soggetti artistici realizzati da Michele Astolfi, tra cui l'Araba fenice, figura leggendaria che simboleggia la bellezza, il rinnovamento e la longevità.

Starlight is the new capsule collection presented by Visionnaire to outline a metropolitan and emotional lifestyle.

Developed inside the maison, this collection's inspiration comes from nature in its fullest translation into universal symbols. The moon gate, with its sense of cyclical "perfection" and opening of living spaces to the natural world. The nest, symbol of protection and renewal of life. Curved, enveloping forms for a collection made of soft volumes and compact sizes for metropolitan apartments, avoiding sharp corners and edges in favor of an organic aesthetic packed with details.

Starlight showcases Visionnaire's ability to create unique projects, reflecting the company's DNA, but also a talent for absorbing the symbols and images of the countries in which the firm operates, translating them into objects with a vividly unique identity. Starlight is a capsule collection that touches on all the spaces of the home, starting with the living zones all the way to the definition of new artistic subjects by Michele Astolfi, including the "Araba Fenice", a legendary figure that represents beauty, renewal and longevity.



INDEX

RHAPSODY sofa	8	BONNIE chair	94
FRANKY low table	26	PALACE dining table	104
BLUEMINE armchair	34	MAJESTIC low unit high unit	116 122
MEMPHIS sofa	42	LE COMTE bed bedside table	132 142
KHAMMA armchair	56	AMBASSADOR writing desk	148
TRAPEZE low table	64	SEKTOR office armchair	164
KORVAC low table	74	MILLER sofa sofa unicum low table	172 188 202
MORGAN dining table	80		









RHAPSODY
sofa

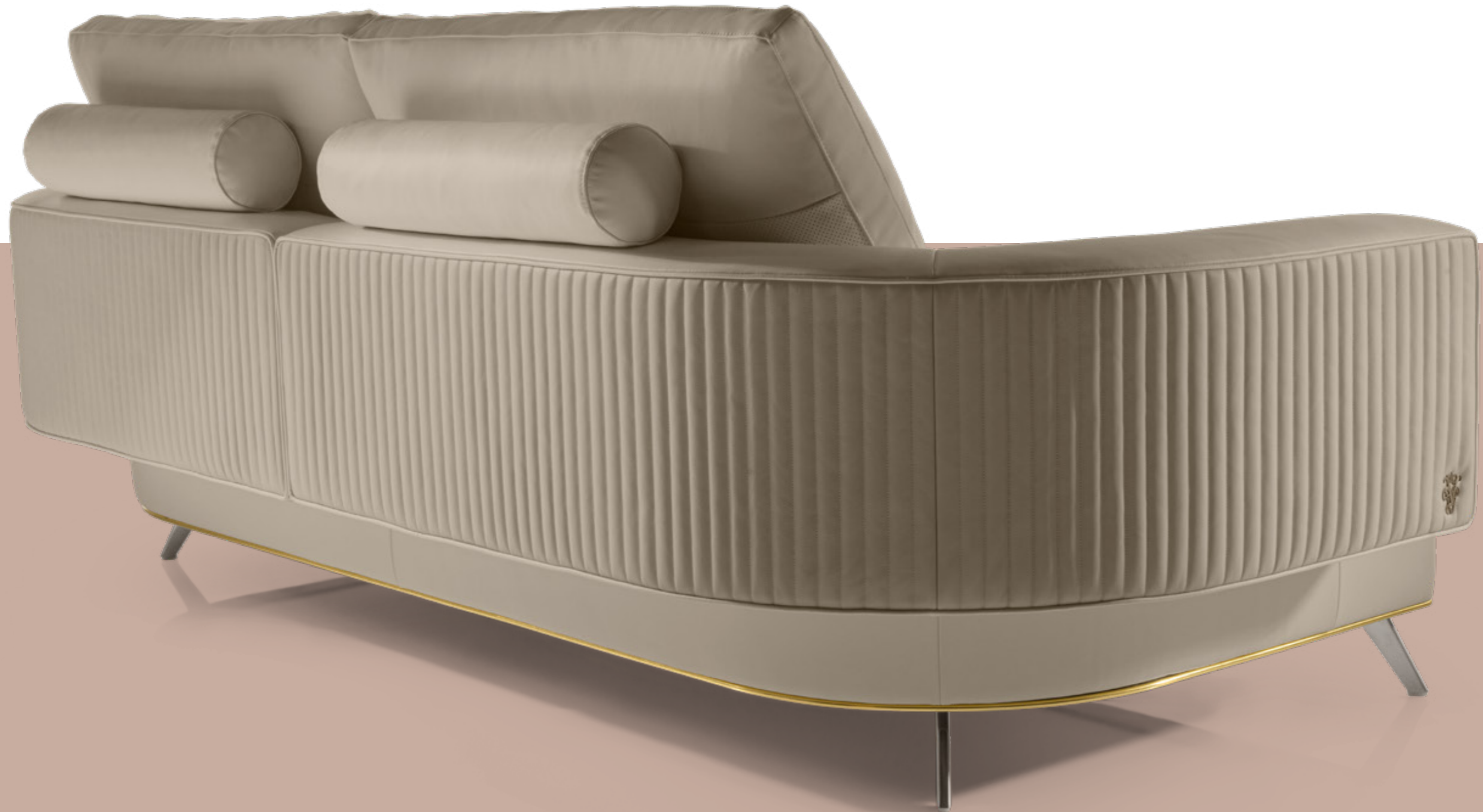

Soft leather 1280 argilla



Satinized champagne



RILAPSODY

238x100 H.87cm

Upholstery in Soft leather 1280 argilla. Backrest upholstered in Soft leather 1280 argilla, with cannettè quilted motif. Base in steel with satinized champagne lacquered finish.

● [click here](#)



Soft leather 1280 argilla



Madras 1153 terra

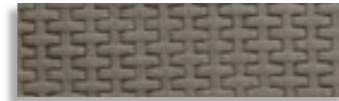

Satinized champagne



RHAPSODY

238x100 H.87cm

Upholstery in Soft leather 1280 argilla. Back in leather Madras 24301/13 terra.
Base in steel with satinized champagne lacquered finish.



RHAPSODY

technical drawings

Divano, poltrona
Sofa, armchair

Design
Fabio Bonfà

Divano in pelle o tessuto, fusto in multistrati e massello di legno con telaio di seduta molleggiato con cinghie elastiche e fusto di braccioli e schienale curvo. Imbottitura della scocca e cuscini di seduta in poliuretano a densità differenziate e falda. Cuscini di schienale e reggireni in piuma. Elementi di sostegno tubolari per gli schienali in poliuretano fissati al retro dei cuscini schienale. Il retro schienale è disponibile in pelle o tessuto a contrasto di colore con trapuntatura cannettata o in pelle stampata con motivo a intreccio. Filetti a contrasto in pelle. Logo Visionnaire in ottone cromato sul bracciolo sinistro. Piedi e profilo inferiore in alluminio. Le parti metalliche sono disponibili nelle finiture metalliche oro e cromo. Nelle misure più grandi il divano è fornito smontato in due metà, con 4 piedi ciascuna. Cuscini reggireni disponibili in contrasto.

Sofa in leather or fabric, structure in plywood and solid wood, seat frame webbed with elastic belts and curved armrest and backrest structure. Padding of external structure and seat cushions in polyurethane with different densities and acrylic fiber. Back cushions and small cushions in feather. Backrest tubular supports in polyurethane foam, fixed to the rear of the back cushions. Rearback available with leather or fabric contrasting upholstery with cannetté quilting or in leather with printed interwoven pattern. Piping in contrasting leather. Visionnaire logo in chromed brass on the left armrest. Feet and lower profiles in aluminium. Metal parts available with gold or chrome lacquered finish. For larger sizes, the sofa is packed disassembled in 2 parts, with 4 feet each. Small back cushions available in contrasting colours.

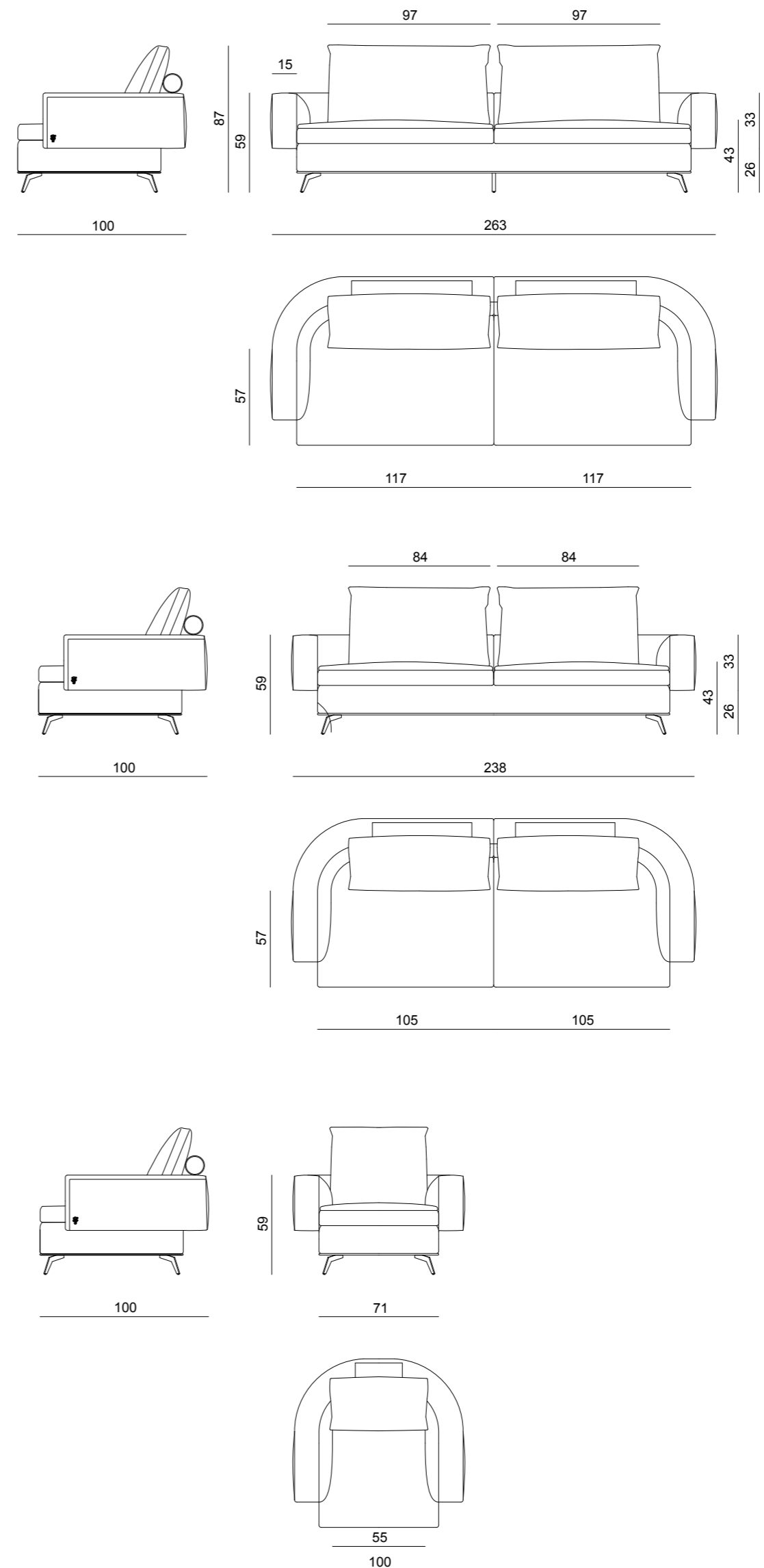
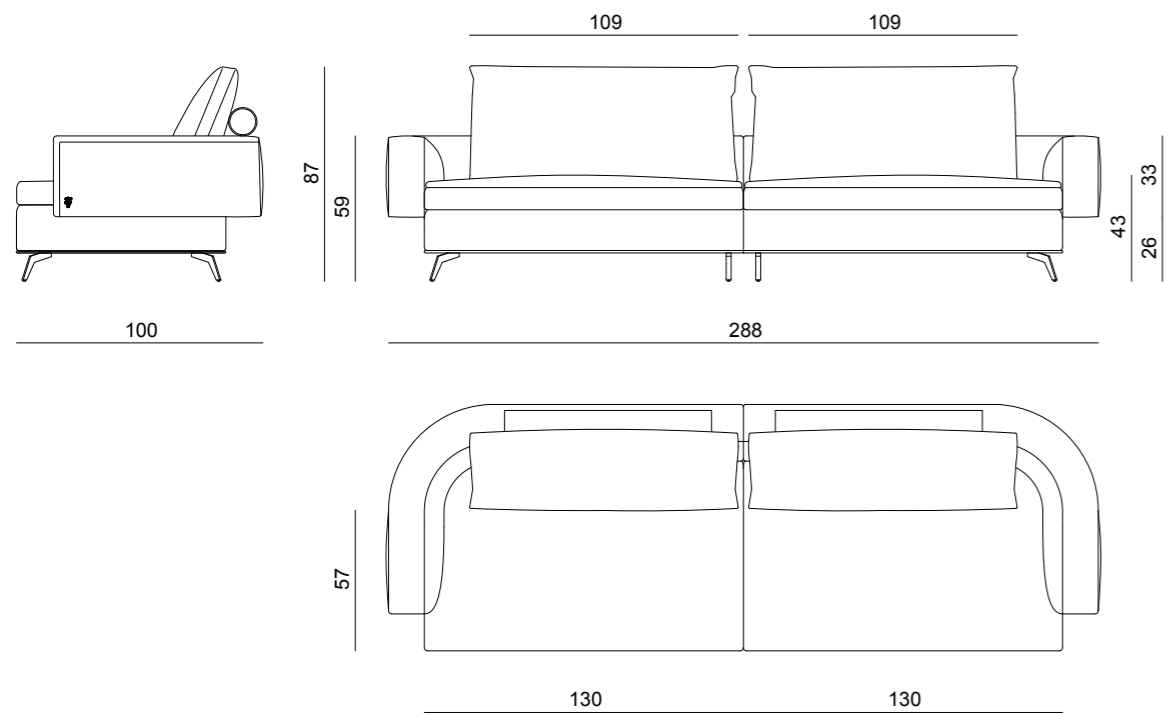

FRANKY
low table





Dover White marble

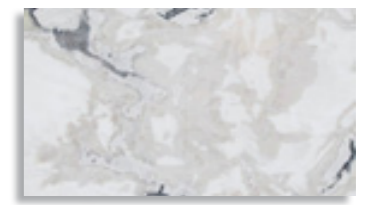

Soft leather 1280 argilla

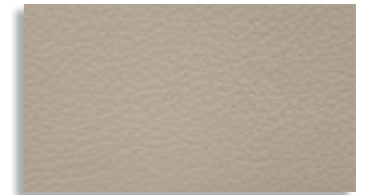

Satinized champagne



FRANKY

Ø120 H.35 cm

Top in Dover White marble. Main structure and profile base upholstered in Soft leather 1280 argilla. Base in steel with satinized champagne lacquered finish.

● [click here](#)



FRANKY

Ø50 H.55 cm

Top in Dover White marble. Main structure and profile base upholstered in Soft leather 1280 argilla. Base in steel with satinized champagne lacquered finish.

● [click here](#)



Dover White marble

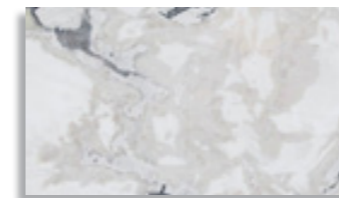

Soft leather 1280 argilla

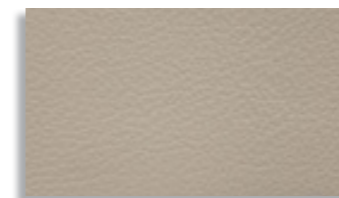

Satinized champagne



FRANKY

technical drawings

Tavolo basso
Low table

Design
Fabio Bonfà

Tavolo basso in acciaio e marmo. Telaio portante e basamento in acciaio inox tubolare di grande diametro e rivestimento in pelle. Sotto-top in legno laccato opaco e bordo sagomato in pelle con cuciture a due aghi ribattute sugli spigoli. Top incassato in marmo lucidato. Le parti metalliche sono disponibili nella selezione finiture metalliche.

Low table in steel and marble. Supporting frame and base in stainless steel with large tubular section and upholstery in leather. Undertop lacquered with mat finish and shaped edge covered in leather with double overlock stitching on the corners. Built-in top in polished marble. Metal parts available with polished and satin metal lacquered finish.

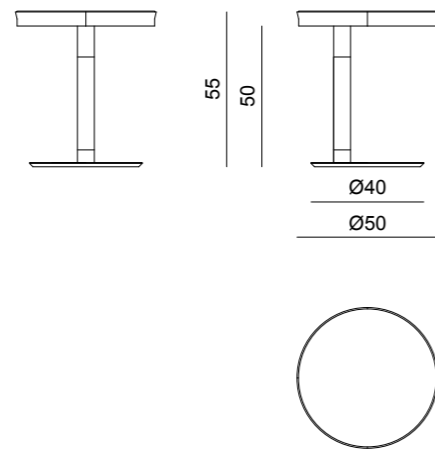
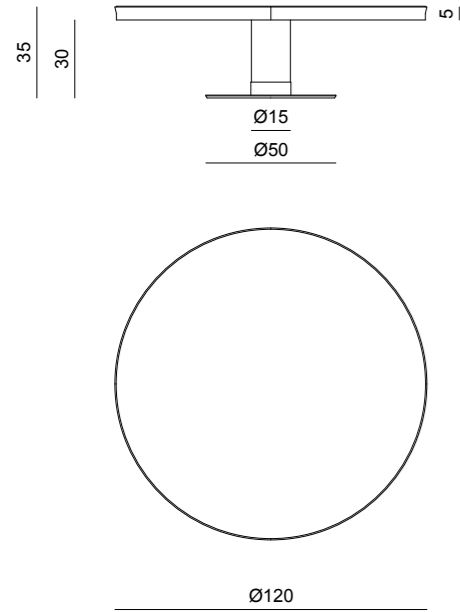





BLUEMINE
armchair



BLUEMINE

94x93 H.74 cm

Upholstery in Prado 24329/02 tortora with pipings and back in Soft leather 1280 argilla. Base in lacquered wood RAL 7039. Legs in steel with satinized champagne lacquered finish.

Upholstery in Prado 24329/06 nocciola with pipings and back in Soft leather 1236 kaki. Base in lacquered wood NCS S4010-Y30R. Legs in steel with satinized champagne lacquered finish.

● [click here](#)

Prado 24329/02 tortora



Soft leather 1280 argilla



RAL 7039



Satinized champagne



Prado 24329/06 nocciola



Soft leather 1236 kaki



NCS S4010-Y30R



Satinized champagne



BLUEMINE

technical drawings

Poltrona
Armchair

Design
Fabio Bonfà

Poltrona in pelle o tessuto con scocca tappezzata in due toni. Fusto e schienale in multistrati e massello in legno con telaio di seduta molleggiato con cinghie elastiche e fusto di braccioli e schienale curvo. Imbottitura e cuscino in poliuretano a densità differenziate, telaio di seduta in legno raccordato con finitura in poliestere lucido (colori RAL/NCS). Piedi e telaio inferiore in acciaio inox conificato disponibili nella selezione finiture metalliche satiniate. Filetti sedile e schienale in pelle a contrasto. Cuscino reggireni con rivestimento a contrasto.

Armchair in leather or fabric with bi-colour upholstered structure. Structure and backrest in plywood and solid wood with seat frame webbed with elastic belts and curved armrest and backrest structure. Padding of external structure and cushion in polyurethane with different densities, seat frame in wood finished with glossy polyester coating (RAL/NCS colours). Feet and lower frame in conic stainless steel available with satin metal lacquered finish. Seat and back piping in contrasting leather. Small back cushions with contrasting upholstery.

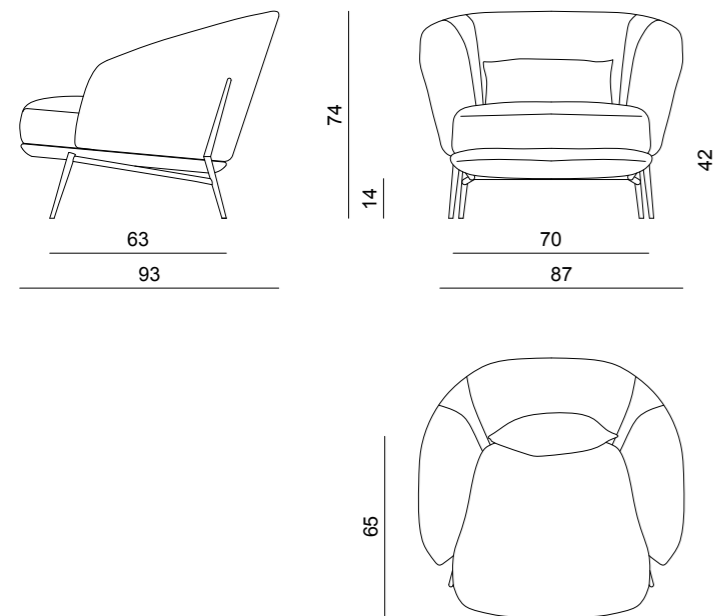







MEMPHIS

sofa



MEMPHIS

278x101 H.72 cm

Upholstery in Sequoia 24314/09 calce. Piping, upper part of the back and armrests in Soft Leather 1131 beola. Side pockets in Tender 24309/28 argento with "Venezia" print. Loose cushions 50x70 cm in Sequoia 24314/09 calce with piping in Soft Leather 1131 beola and "V" embroidered logo. Base in steel with satinized champagne lacquered finish.

Sequoia 24314/09 calce

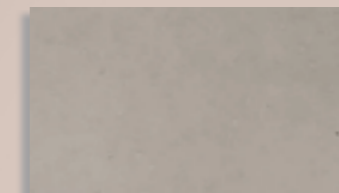

Tender 24309/28 argento
"Venezia" print



Soft Leather 1131 beola

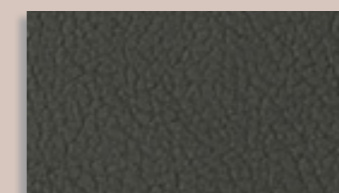

Satinized champagne





MEMPHIS

278x101 H.72 cm

Upholstery in Sequoia 24314/09 calce. Piping, upper part of the back and armrests in Soft Leather 1173 elefante. Side pockets in Soft Leather 1173 elefante with "Venezia" print. Loose cushions 50x70 cm in Sequoia 24314/09 calce with piping in Soft Leather 1173 elefante and "V" embroidered logo. Base in steel with satinized champagne lacquered finish.

● [click here](#)

Sequoia 24314/09 calce

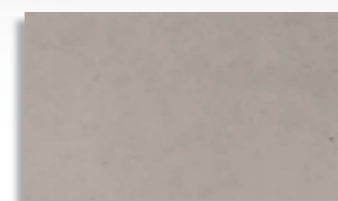

Soft Leather 1139 anemone
"Venezia" print



Soft Leather 1173 elefante

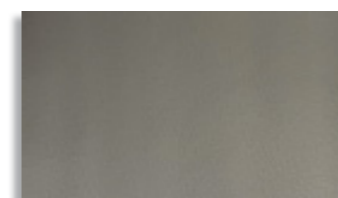

Satinized champagne





MEMPHIS

technical drawings

Divano
Sofa

Design
La Conca

Divano in pelle o tessuto, fusto in multistrati e massello di legno con telaio di seduta molleggiato con cinghie elastiche. Imbottitura della scocca e cuscini di seduta in poliuretano a densità differenziate e falda. I cuscini di schienale, il retro schienale e l'esterno dei braccioli sono decorati con piping in contrasto. In opzione, l'esterno dei braccioli può ospitare una tasca in pelle stampata per piccoli oggetti, con bordo in pelle e logo Visionnaire in ottone cromato. Filetti a contrasto in pelle. Elemento paraspigoli con logo in acciaio inox e ottone cromato sotto il sedile. Piedi in acciaio inox con elementi tubolari sovrapposti. Le parti metalliche sono disponibili nella selezione finiture metalliche satiniate.

Sofa in leather or fabric, structure in plywood and solid wood, seat frame webbed with elastic belts. Padding of external structure and seat cushions in polyurethane with different densities and acrylic fiber. The back cushions, the rear back and the external part of the armrests are decorated with contrasting piping. In option, the external part of the armrest can be equipped with a pocket in printed leather suitable for small items and decorated with leather edge and Visionnaire logo in chromed brass. Contrasting piping in leather. Corner protectors with logo in stainless steel and chromed brass under the seat. Feet in stainless steel with overlying tubular elements. Metal parts available with satin metal lacquered finish.

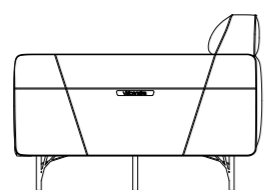
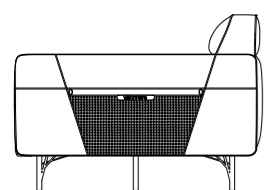

101

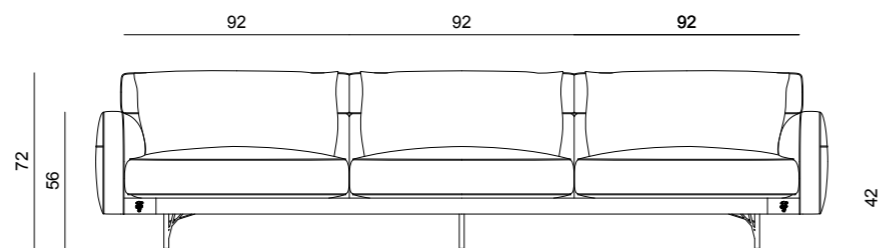

298

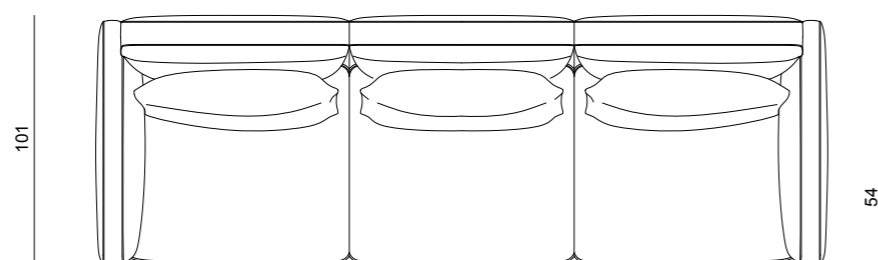

101

54

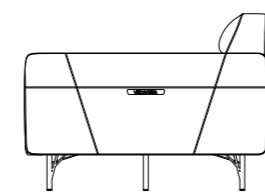
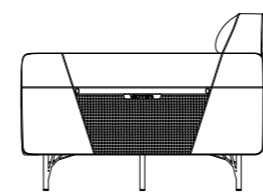

101

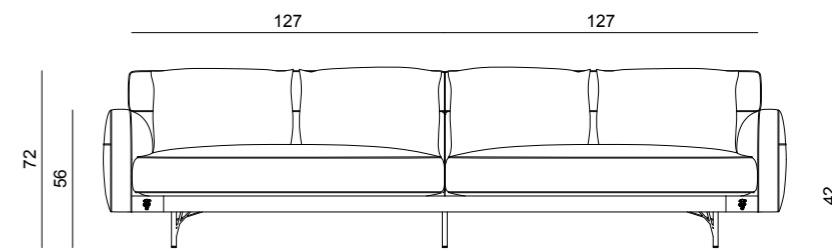

278

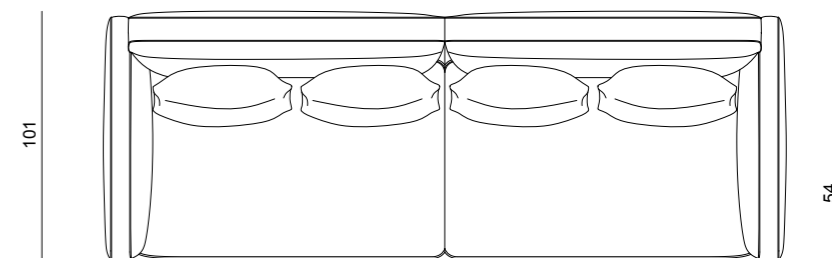

101

54

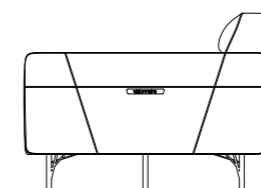
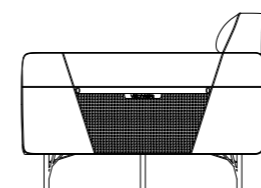

101

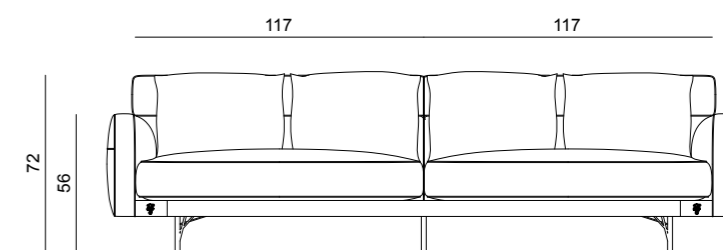

258

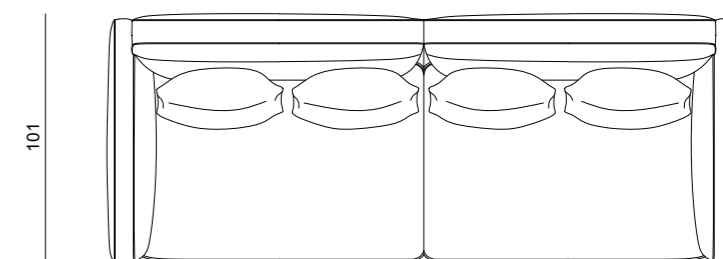

101

54

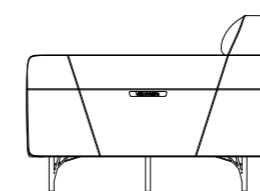
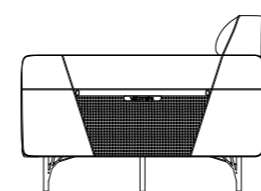

101

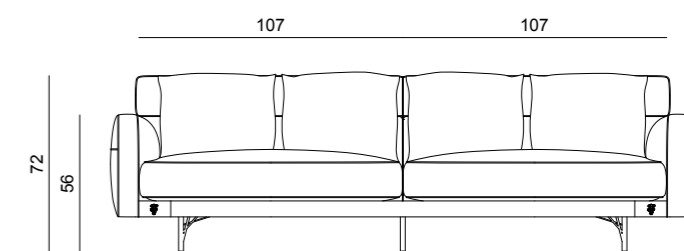

238

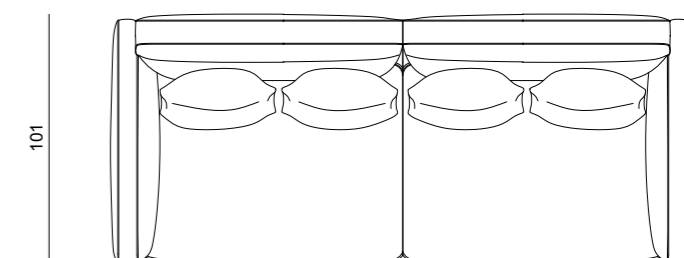

101

54





KHAMMA
armchair



KHAMMA

93x82 H.70 cm

Main upholstery in Prado 24329/01 ostrica with piping in Soft leather 1135 cioccolato. Loose cushion 40x40 cm in Prado 24329/01 ostrica with piping in Soft leather 1135 cioccolato and "V" embroidered logo. Swivel base in steel with satinized champagne lacquered finish.

Main upholstery in Aston 24051/254 alluminio with piping in Sequoia 24314/09 Calce. Loose cushion 40x40 cm in Aston 24051/254 alluminio with piping in Sequoia 24314/09 Calce and "V" embroidered logo. Swivel base in steel with satinized champagne lacquered finish.

● [click here](#)



Prado 24329/01 ostrica

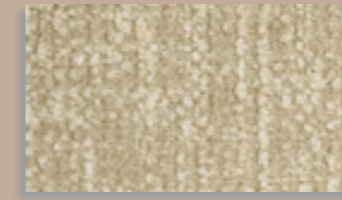

Soft leather 1135 cioccolato

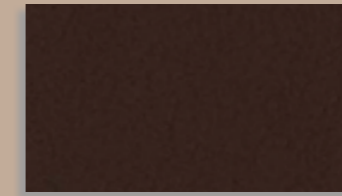

Satinized champagne



Aston 24051/254 alluminio



Sequoia 24314/09 Calce



Satinized champagne



KHAMMA

technical drawings

Poltrona
Armchair

Design
La Conca

Poltrona in pelle o tessuto, fusto in multistrati e massello di legno con telaio di seduta molleggiato con cinghie elastiche e fusto di braccioli e schienale curvo. Imbottitura della scocca e cuscini di seduta in poliuretano a densità differenziate e falda acrilica. Cuscino di schienale in piuma. Filetti a contrasto in pelle e logo Visionnaire ricamato sul cuscino di schienale. Basamento tubolare in acciaio inox disponibile nella selezione finiture metalliche satinare, con attacco centrale e sistema rotante auto allineante.

Armchair in leather or fabric with bi-colour upholstered structure. Structure and backrest in plywood and solid wood with seat frame webbed with elastic belts and curved armrest and backrest structure. Padding of external structure and seat cushion in polyurethane with different densities and acrylic fiber. Back cushion in feather. Piping in contrasting leather and logo embroidered on the small back cushion. Tubular base in stainless steel available with satin metal lacquered finish, fixed to the centre of the underseat structure and equipped with self-aligning rotating system.

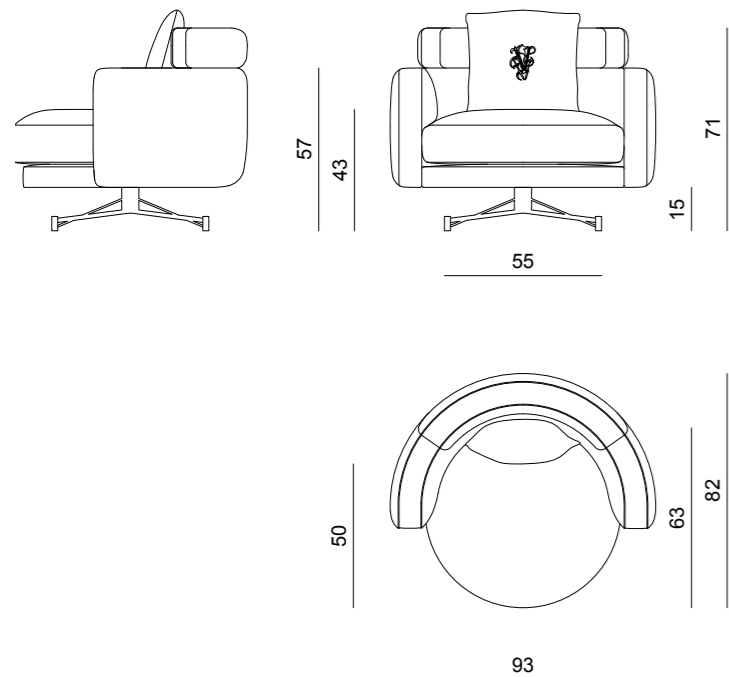





TRAPEZE
low table

Verde Saint Denis marble

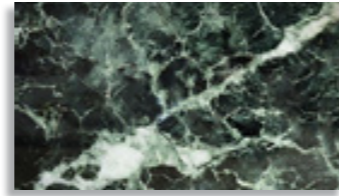

RAL 9005



Polished champagne



TRAPEZE

160x77 H.38 cm

Upper top in Verde Saint Denis marble, lower top in lacquered wood in polished RAL 9005. Legs in steel with champagne lacquered finish.

Upper top in Dover White marble, lower top in lacquered wood in Jolie Grey marble. Legs in steel with champagne lacquered finish.

● [click here](#)

Dover White marble

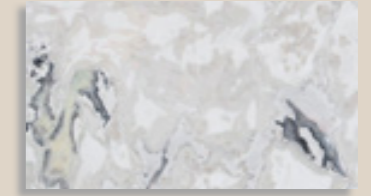

Jolie Grey marble



Polished champagne





TRAPEZE

53x55 H.55 cm

Upper top in Verde Saint Denis marble, lower top in lacquered wood in polished RAL 9005. Legs in steel with champagne lacquered finish.

Upper top in Dover White marble, lower top in lacquered wood in RAL 7039. Legs in steel with champagne lacquered finish.

● [click here](#)

Verde Saint Denis marble



RAL 9005



Polished champagne



Dover White marble

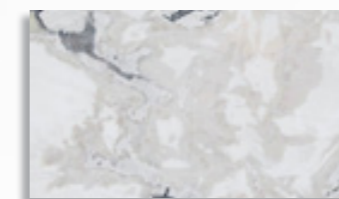

RAL 7039



Polished champagne



TRAPEZE

technical drawings

Tavolo basso
Low table

Design
La Conca

Tavolo basso in marmo e legno laccato. Top in marmo lucido con bordo sagomato a mezzo toro e sotto-top in HPL ad alta resistenza. Top inferiore in legno laccato lucido (colori RAL/NCS), bordo a mezzo toro e logo Visionnaire in ottone cromato leggermente incassato. Quattro piedi in acciaio inox con elementi tubolari sovrapposti. Le parti metalliche sono disponibili nella selezione finiture metalliche. Disponibile anche con top inferiore in marmo a contrasto.

Low table in marble and lacquered wood. Top in polished marble with shaped half bullnose edge and undertop in HPL with high resistance. Lower top in polish lacquered wood (RAL/NCS colours), shaped half bullnose edge and Visionnaire logo in chromed brass slightly embedded in the structure. 4 feet in stainless steel with overlying tubular elements. Metal parts available in polished and satin metal finish. Also available with lower top in contrasting marble.

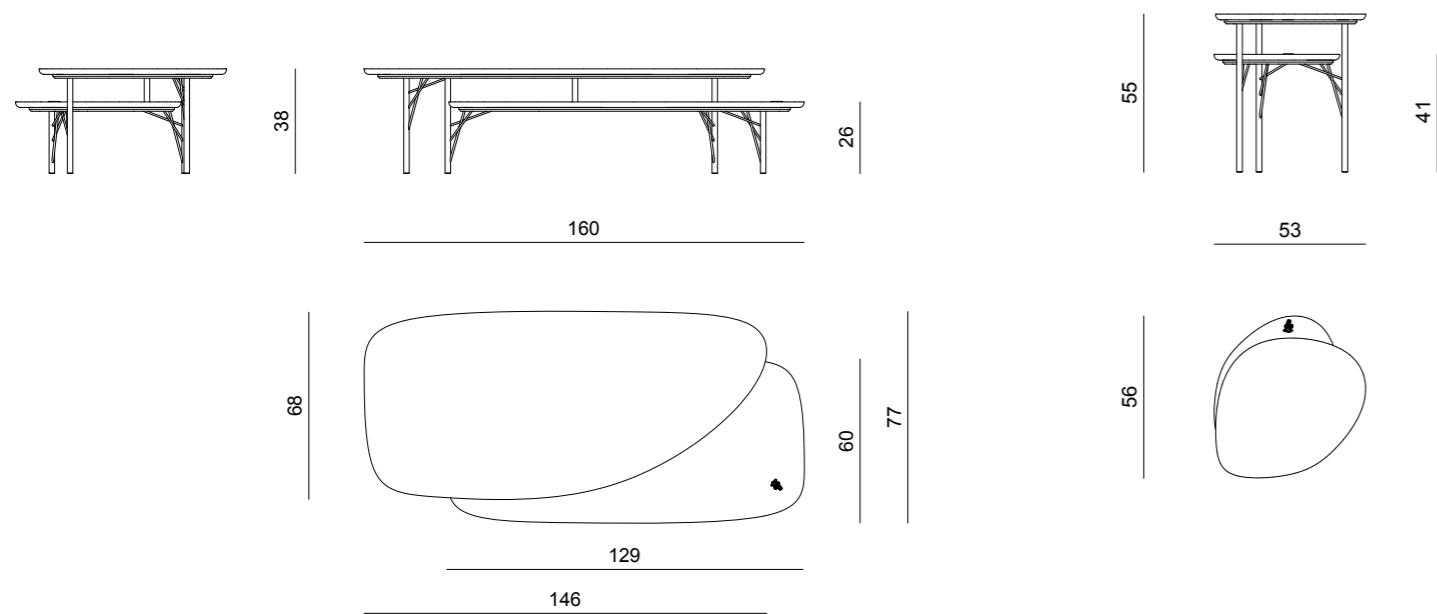



KORVAC
low table



KORVAC

Ø120 H.40cm

Top in Dover White marble. Top profile in lacquered wood in polished RAL 7037. Drawer upholstered in Soft leather 1184 peltro. Leg and base in steel with satinized champagne lacquered finish.

● [click here](#)

Dover White marble

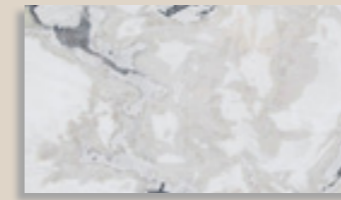

Soft leather 1184 peltro



RAL 7037

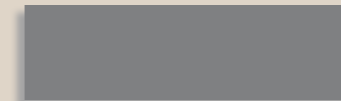

Satinized champagne



KORVAC

technical drawings

Tavolo basso
Low table

Design
Fabio Bonfà

Tavolo basso in acciaio e marmo. Telaio portante e basamento in acciaio inox tubolare di grande diametro. Top in marmo con bordo sagomato a mezzo toro e sotto-top in legno laccato lucido con bordo a mezzo toro con profilo metallico di separazione con fibbie decorative in ottone cromato con logo inciso. Vano sotto-top dotato di due cassetti rivestito in pelle con cuciture sugli spigoli e loghi in ottone cromato. Le parti metalliche sono disponibili nella selezione finiture metalliche.

Low table in steel and marble. Supporting frame and base in stainless steel with large tubular section. Top in marble with shaped half bullnose edge and undertop in polished lacquered wood with half bullnose edge, metal divisory profile equipped with chromed brass buckles with engraved logo. Undertop compartment provided with 2 drawers upholstered in leather with stitching on the edges and chromed brass logos. Metal parts available with polished or satin lacquered finish.

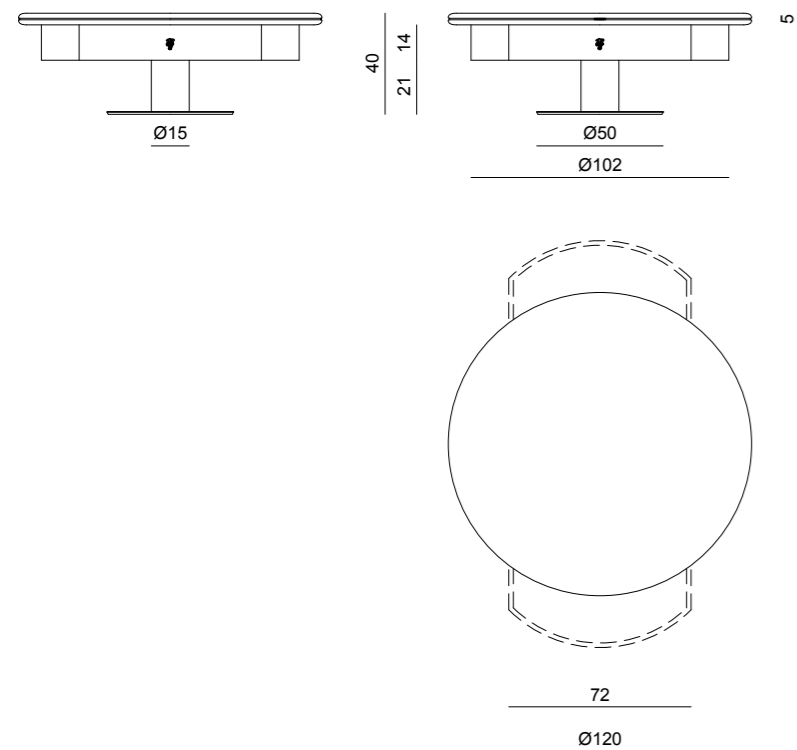









MORGAN
dining table



MORGAN

Ø160 H.75 cm

Top and Lazy Susan in Dover White and Jolie Grey marble. Undertop and profile in lacquered wood RAL 7037. Legs upholstery in Tender 24309/29 grigio. Base in stainless steel with satinized champagne finish.

● [click here](#)

Dover White & Jolie Grey marble

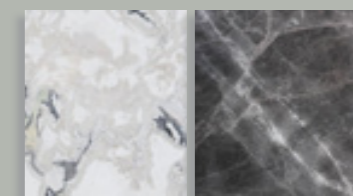

Tender 24309/29 grigio



RAL 7037



Satinized champagne





MORGAN

260x110 H.75 cm

Top in Dover White marble. Undertop and profile in lacquered wood RAL 7037. Legs upholstery in Tender 24309/29 grigio. Base in stainless steel with satinized champagne finish.

Dover White marble

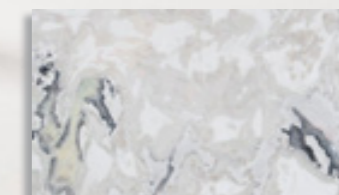

Tender 24309/29 grigio



RAL 7037



Satinized champagne



MORGAN

technical drawings

Tavolo da pranzo
Dining table

Design
Fabio Bonfà

Tavolo da pranzo in marmo. Top in due marmi lucidati con bordo sagomato a mezzo toro e sotto-top in legno laccato lucido con bordo a mezzo toro (colori RAL), con profilo metallico di separazione con fibbie decorative in ottone cromato con logo inciso. Lazy susan in appoggio in due marmi lucidati, asportabile. I due marmi formano un disegno geometrico con grafica complementare. Basamento formato da tre gambe in tubolare metallico a sezione ovale parzialmente rivestite in pelle e unite al centro in un elemento a stella in metallo satinato con logo in ottone cromato. Le parti metalliche sono disponibili nella selezione finiture metalliche satinate.

Dining table in marble. Top in two types of polished marble with shaped half-bullnose edge and undertop in polished lacquered wood with half-bullnose edge (RAL colours), divisory profil with decorative buckles in chromed brass engraved with logo. Lazy Susan on top in two types of marble, polished and removable. The 2 marbles designe a geometric complementary pattern. Base made of 3 tubular metal legs with oval section, partly covered in leather, connected to a central block in satin metal with chromed brass logo, designing a star shape. Metal parts available with satin metal lacquered finish.

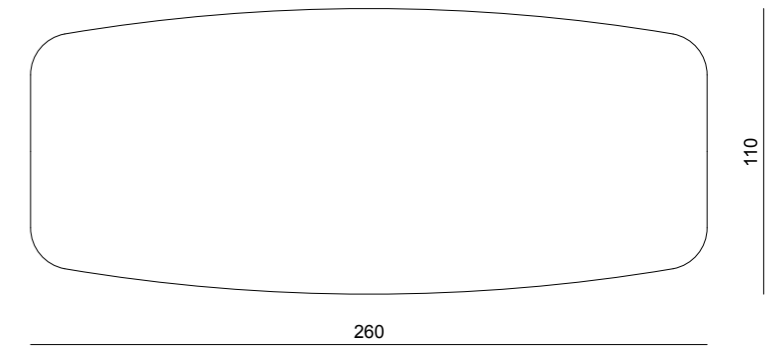
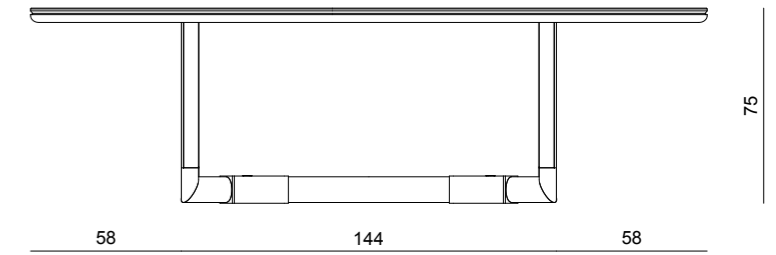
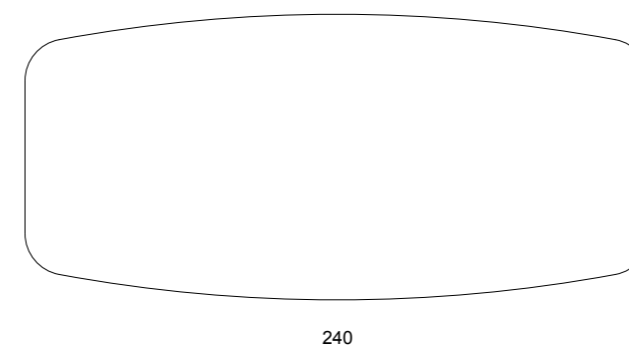
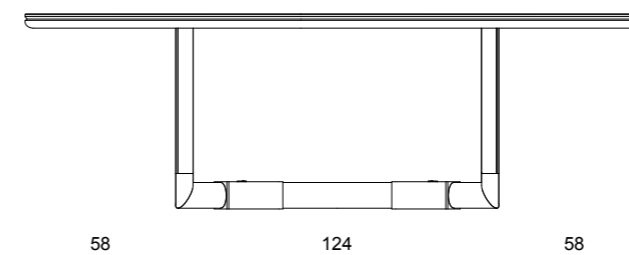
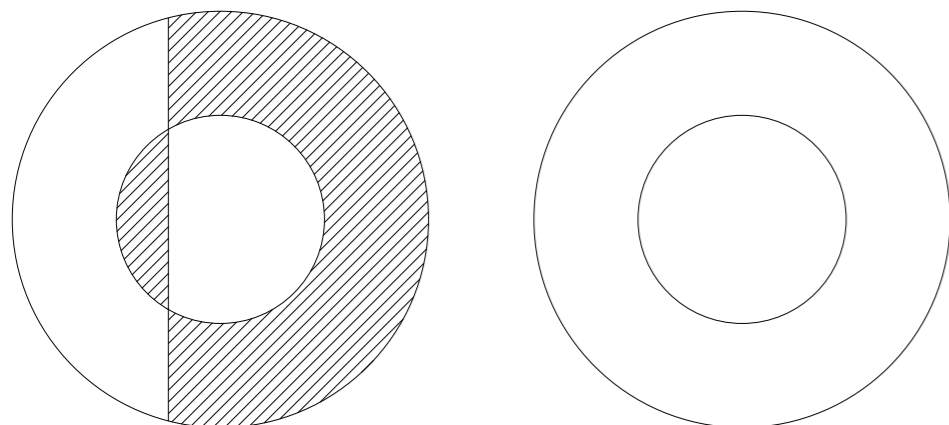
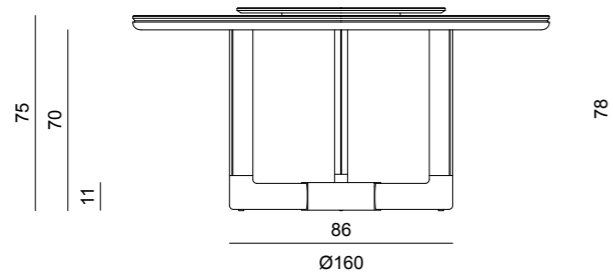
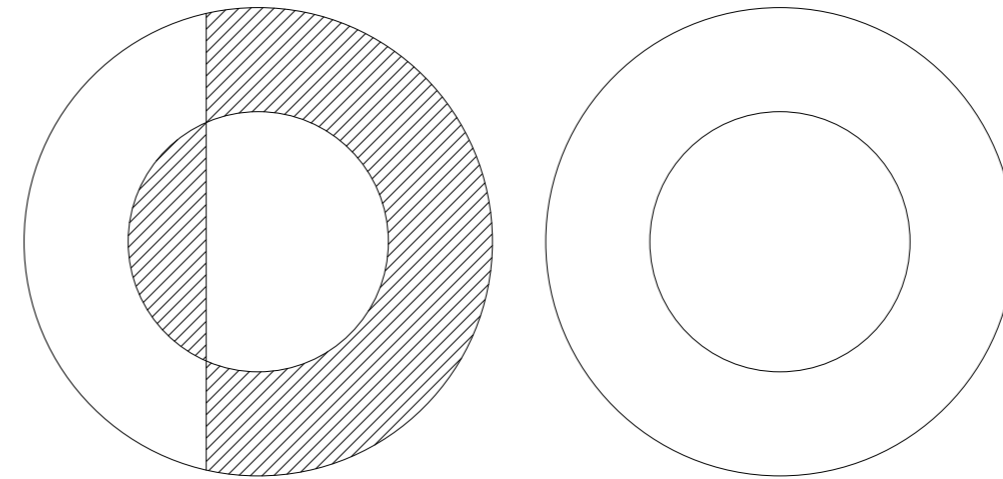
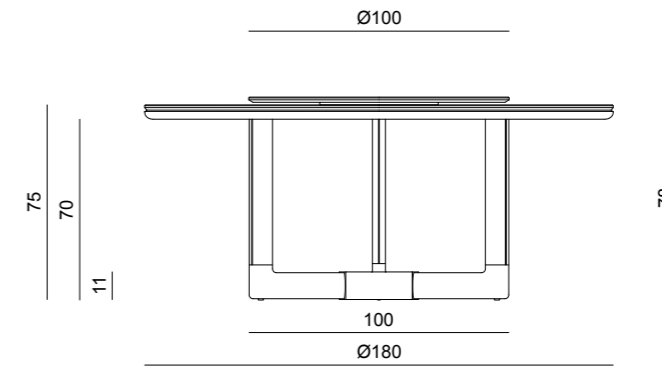







BONNIE
chair



BONNIE

58x57 H.76 cm

Upholstery in Soft leather 1118 canapa with back in leather Taras leather 24296/21 peltro. Structure in stainless steel with satinized champagne finish.

Upholstery in Soft leather 1173 elefante with back in Faber 24229/05 silver. Structure in stainless steel with satinized champagne finish.

● [click here](#)

Soft leather 1118 canapa

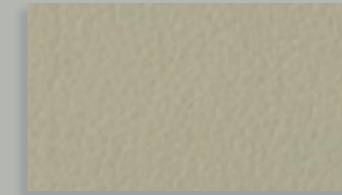

Taras leather 24296/21 peltro

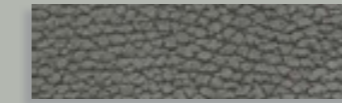

Satinized champagne



Soft leather 1173 elefante



Faber 24229/05 silver



Satinized champagne



BONNIE

technical drawings

Sedia
Chair

Design
La Conca

Sedia imbottita, scocca interna in multistrati di legno curvato, imbottita in poliuretano, con rivestimento in pelle o tessuto a due toni, con filetti a contrasto. Telaio in tubo di acciaio curvato disponibile nella selezione finiture metalliche satinate.

Padded seat, internal frame in curved plywood, padding in polyurethane foam, with dualtone upholstery in leather or fabric, with contrasting piping. Frame in tubular curved steel available with satin metal lacquered finish.

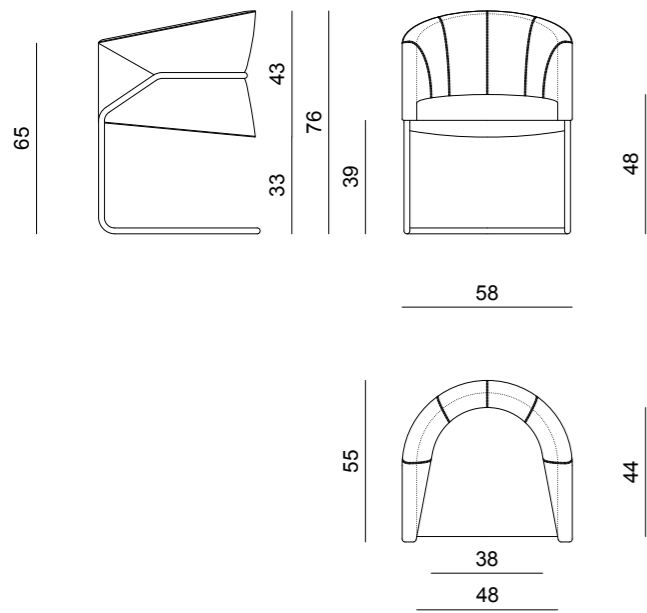



PALACE

dining table



Carrara White & Black
Marquinia marble

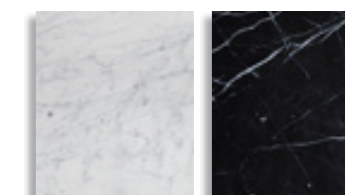

Faber 24229/15 sabbia



RAL 7043



Satinized champagne



PALACE

Ø180 H.75 cm

Top and Lazy Susan in Dover White marble. Undertop and profile in lacquered wood RAL 7043. Legs upholstery in Faber 24229/15 sabbia with internal part and profile in lacquered wood RAL 7043. Metal profiles with satinized champagne finish.



PALACE

Ø180 H.75 cm

Top and Lazy Susan in Dover White marble. Undertop and profile in lacquered wood RAL 7043. Legs upholstery in Faber 24229/15 sabbia with internal part and profile in lacquered wood RAL 7043. Metal profiles with satinized champagne finish.

● [click here](#)

Dover White marble

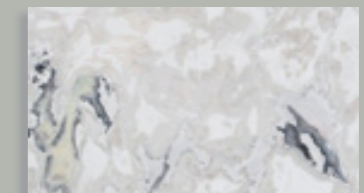

Faber 24229/15 sabbia



RAL 7043



Satinized champagne





MORGAN

260x110 H.75 cm

Top in Dover White marble. Undertop and profile in lacquered wood RAL 7043. Legs upholstery in Faber 24229/15 sabbia with internal part and profile in lacquered wood RAL 7043. Metal profiles with satinized champagne finish.

Dover White marble

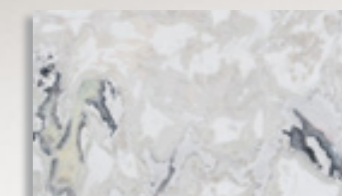

Faber 24229/15 sabbia

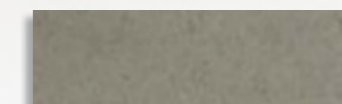

RAL 7043



Satinized champagne





PALACE

technical drawings

Tavolo da pranzo
Dining table

Design
Fabio Bonfà

Tavolo da pranzo in marmo. Top in marmo lucidato con bordo sagomato a mezzo toro e sotto-top in legno laccato lucido con bordo a mezzo toro (colori RAL), con profilo metallico di separazione con fibbie decorative in ottone cromato con logo inciso. Lazy susan in appoggio in marmo lucidato, asportabile. Basamento formato da due plinti sfaccettati in legno laccato lucido e superfici esterne rivestite in pelle o tessuto con lavorazione a trapunta cannettata. Le parti metalliche sono disponibili nella selezione finiture metalliche satinare.

Dining table in marble. Top in polished marble with shaped half-bullnose edge and under-top in polish lacquered wood with half-bullnose edge, metal divisory profil with decorative buckles in chromed brass engraved with logo. Lazy susan on top made in polished marble. Base made of 2 multi-faceted pillars in polished lacquered wood and external surfaces covered in leather or fabric, decorated with cannetté quilted motif. Metal parts available with satin or polished metal lacquered finish.

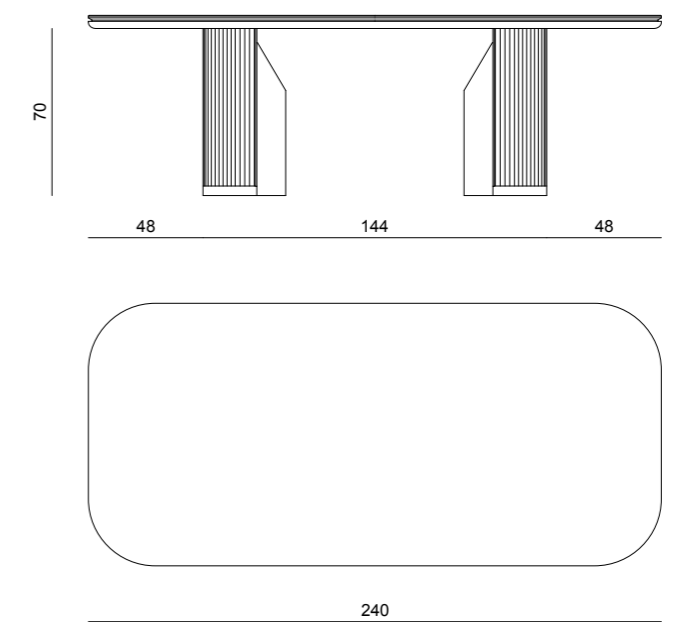
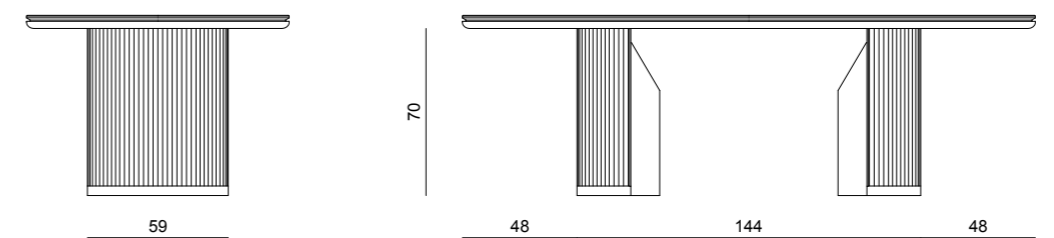
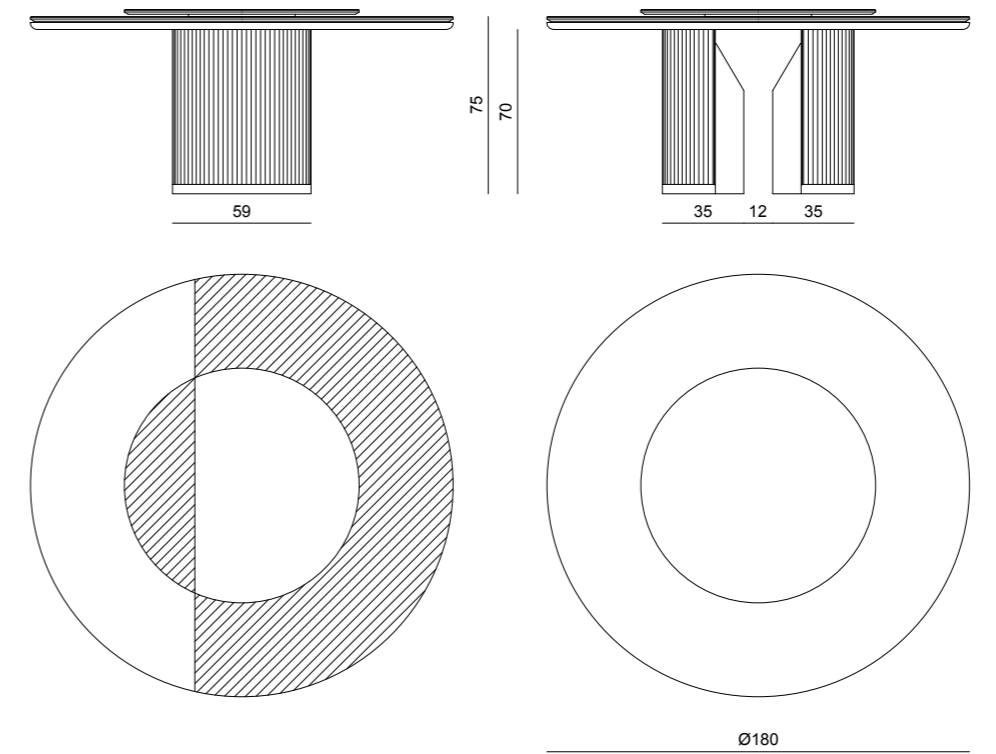
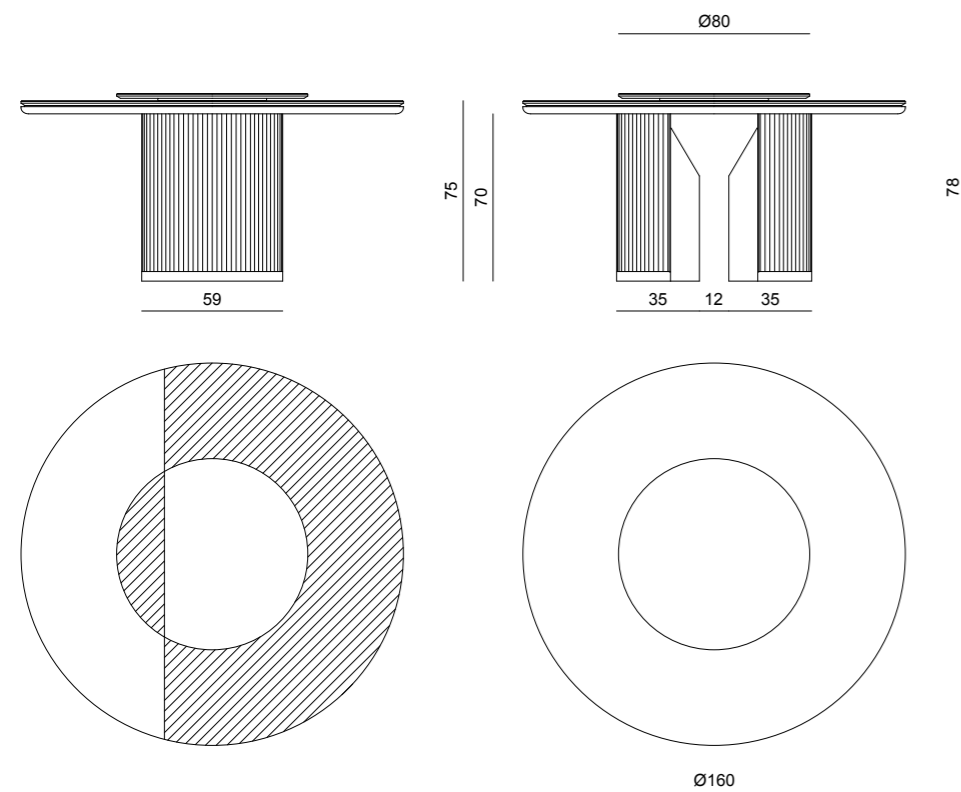











Portoro Silver marble

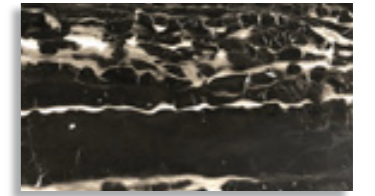

Faber 24229/05 silver
cannetè motif



Metal Anthrax

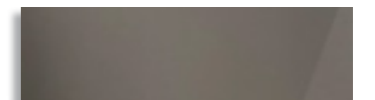

Lacquered champagne



MAJESTIC

240x54 H.85 cm

Main structure in solid wood with upper part in lacquered in Metal Anthrax colour and lower part upholstered in Faber 24229/05 silver with cannetè motif. Top in Portoro Silver marble. Feet and drawers profile in stainless steel with polished champagne finish.

● [click here](#)



MAJESTIC
low unit



MAJESTIC

240x54 H.55 cm

Main structure in solid wood with upper part in lacquered RAL 1013 and lower part upholstered in Faber 24229/05 silver "pixel" print. Top in Calacatta marble. Feet and drawers profile in stainless steel with polished champagne finish.

● [click here](#)

Calacatta marble



Faber 24229/05 silver "pixel" print

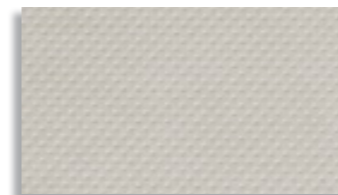

RAL 1013

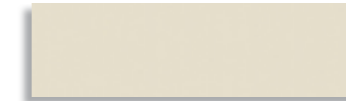

Lacquered champagne



MAJESTIC

technical drawings

Madia, mobile basso
High unit, low unit

Design
La Conca

Mobile basso a 4 ante, scocca in MDF sagomato con fianchi curvi, con superfici laccate (colori RAL) e parte inferiore rivestita in pelle o tessuto, separate da un profilo in acciaio inox lucido con traiettoria inclinata. Top incassato in marmo lucidato. Basamento in legno rivestito in acciaio inox lucido, oppure piedi in acciaio inox lucido con elementi tubolari a disposizione piramidale. Logo Visionnaire in ottone cromato sullo sportello sinistro. Ripiano interno in cristallo extra-chiaro e passacavi per device nel vano centrale. Le parti metalliche sono disponibili nella selezione finiture metalliche. Il rivestimento inferiore esterno è disponibile con lavorazione a trapunta cannettata con cuciture tono su tono.

Low unit with 4 doors, external structure in shaped MDF with curved sides, lacquered surface (RAL colours) and lower part upholstered in leather or fabric, divided by a polish stainless steel sloping profile. Built-in top in polished marble. Wooden base covered in polished stainless steel, or feet in polished stainless steel with tubular elements shaped as a pyramid. Visionnaire logo in chromed brass on the left door. Internal shelf in extra clear crystal glass and cable passage for devices available in the central compartment. Metal parts are available in polished and satin metal lacquered finish. External lower upholstery available with cannetté quilting with tone on tone stitching.

Madia a 4 ante, scocca in MDF sagomato con fianchi curvi, con superfici laccate (colori RAL) e parte inferiore rivestita in pelle o tessuto, separate da un profilo in acciaio inox lucido con traiettoria inclinata. Top incassato in marmo lucidato. Basamento in legno rivestito in acciaio inox lucido, oppure piedi in acciaio inox lucido con elementi tubolari a disposizione piramidale. Logo Visionnaire in ottone cromato sullo sportello sinistro. Cassetti interni nei 3 vani, con ripiani in cristallo extra-chiaro. Le parti metalliche sono disponibili nella selezione finiture metalliche. Il rivestimento inferiore esterno è disponibile con lavorazione a trapunta cannettata con cuciture tono su tono.

High unit with 4 doors, external structure in shaped MDF with curved sides, lacquered surface (RAL colours) and lower part upholstered in leather or fabric, divided by a polish stainless steel sloping profile. Built-in top in polished marble. Wooden base covered in polished stainless steel, or feet in polished stainless steel with tubular elements shaped as a pyramid. Visionnaire logo in chromed brass on the left door. 3 compartments equipped with internal drawers and extra clear glass shelves. Metal parts available with polished and satin metal lacquered finish. Lower external upholstery available with cannetté quilting with tone on tone stitching.

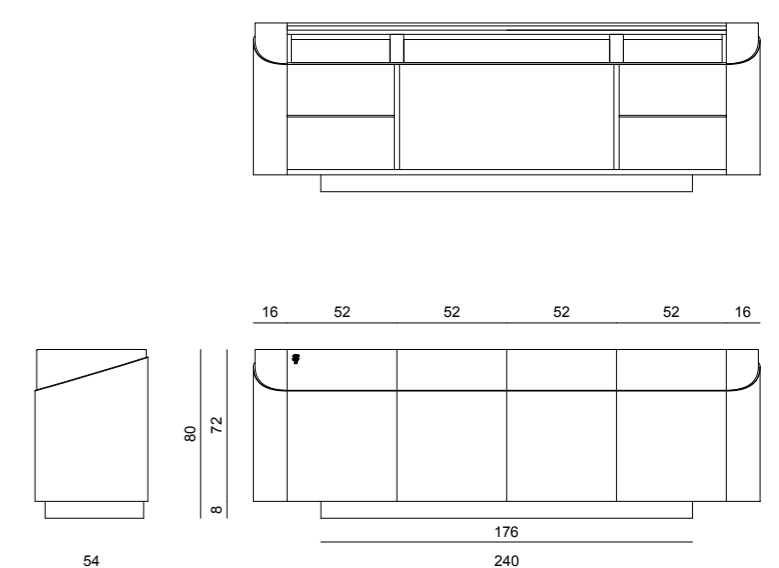
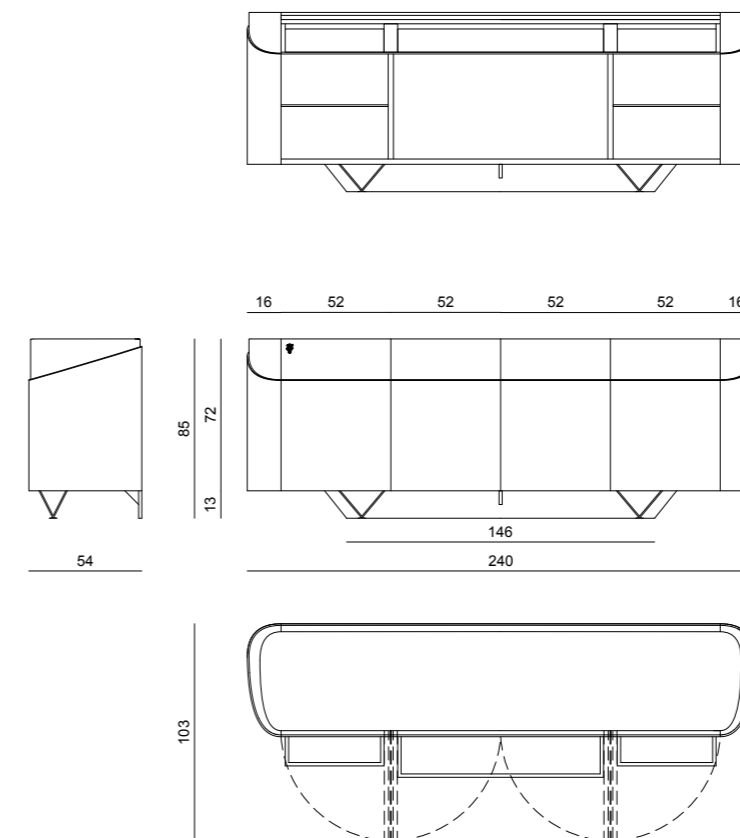
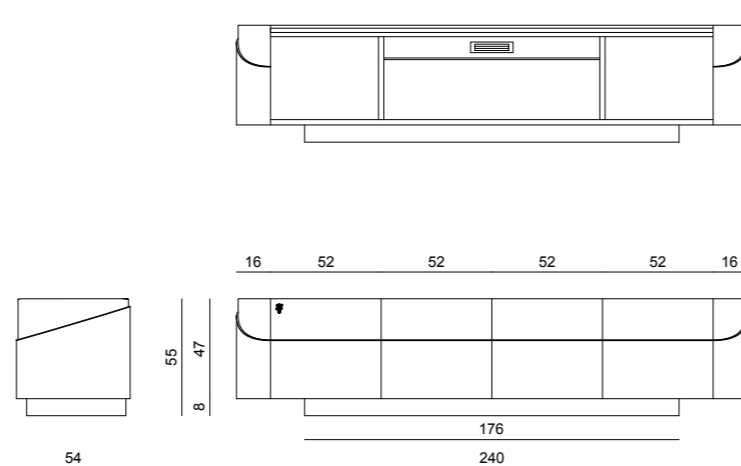
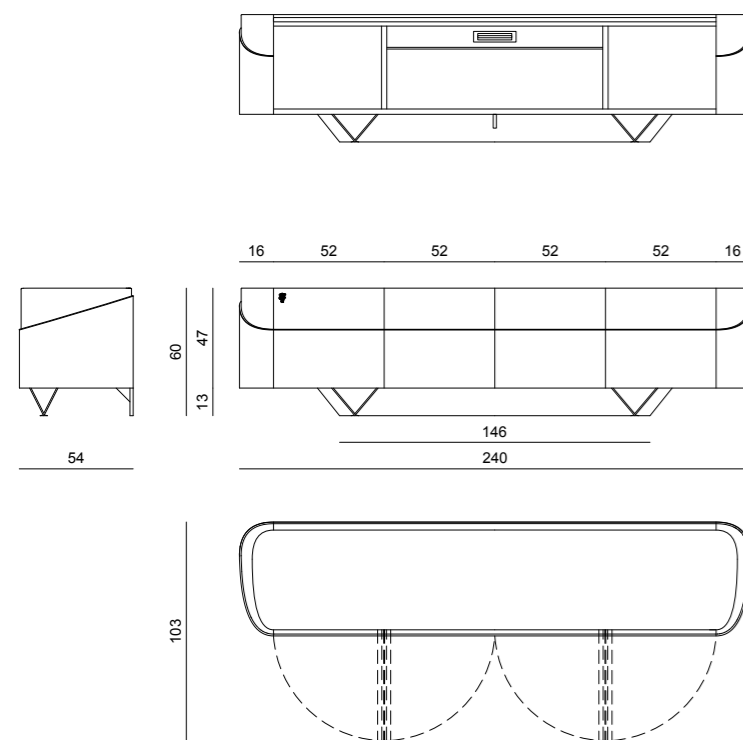







LE COMTE

bed



Classic 24263/23 beige

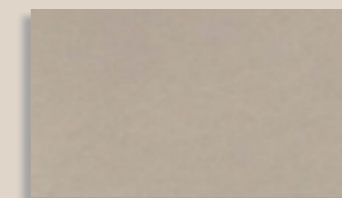

Taras 24296/28 ombra

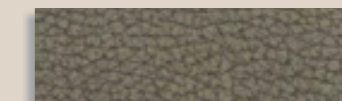

Lacquered gold



LE COMTE

203x237 H.113 cm

Padded bed upholstered in Classic 24263/23 beige with internal part of the headboard and bed frame profile in Taras 24296/28 ombra. Legs in stainless steel with polished gold finish.

● [click here](#)

LE COMTE

technical drawings

Letto
Bed

Design
Fabio Bonfà

Letto imbottito in pelle o tessuto. Testata in multistrati curvato e cuscino poggiatesta imbottito in poliuretano. La testata è rivestita in pelle o tessuto con logo ricamato e cuscino interno poggiatesta rivestito a contrasto. Bordo di finitura della testata in alluminio lucido. Sommier in multistrati di legno diviso in tre parti, rivestito in pelle o tessuto con bordi inferiore e superiore rivestiti a contrasto. Piedi e profilo testata in alluminio. Le parti metalliche sono disponibili nelle finiture metalliche oro e cromo. Abbinabile alle reti a doghe in legno e materassi Visionnaire. Supporti della rete regolabili in altezza.

Padded bed in leather or fabric. Headboard in curved plywood and headrest cushion padded with polyurethane foam. Headrest upholstered in leather or fabric decorated with embroidered logo and pillow inside the headrest provided with contrasting upholstery. Headboard decorative profile in polished aluminium. Bed frame in wood plywood divided in 3 parts, upholstered in leather or fabric, lower and upper edges with contrasting upholstery. Feet and headboard profiles in aluminium. Metal parts available with chrome or gold finish. Suitable for Visionnaire slats and mattresses. Slats supporting brackets with adjustable height.

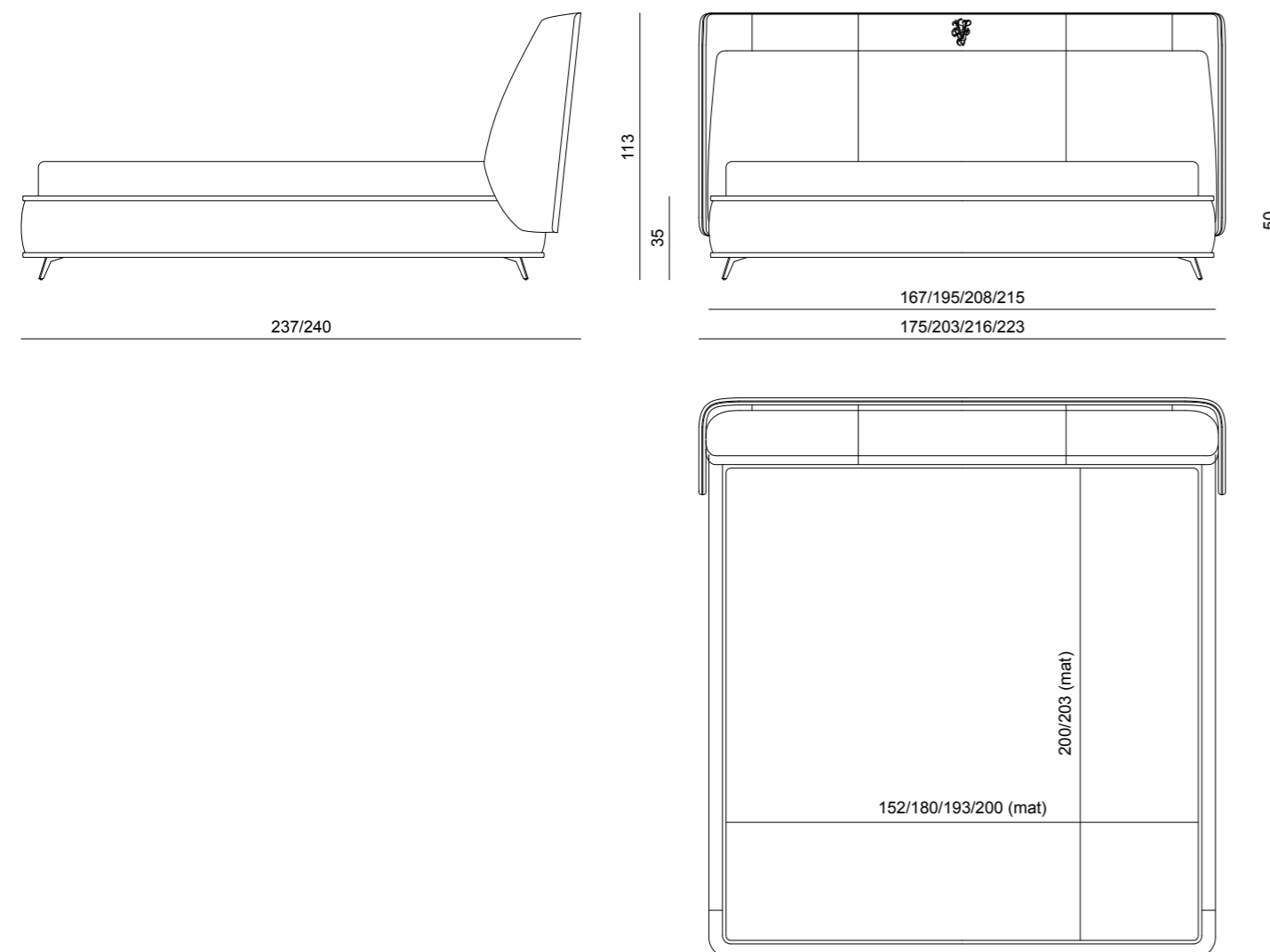



LE COMTE

bedside table



LE COMTE

60x45 H.51 cm

Main structure in wood with upper part upholstered in Soft Leather 1280 argilla, lacquered lower part in RAL 1019. Top in Dover White marble.

Main structure in wood with upper part upholstered in Taras 24296/28 ombra, Drawer upholstered in Classic 24263/23 beige. Lacquered lower part in Metal Anthrax colour. Top in Dover White marble.

● [click here](#)



LE COMTE

technical drawings

Comodino
Bedside table

Design
Fabio Bonfà

Comodino ovale con cassetto. Scocca in MDF sagomato laccato lucido (colori RAL/NCS), cassetto e bordo del top rivestiti in pelle o tessuto a contrasto. Top incassato in marmo lucidato. Il cassetto monta guide a rientro smorzato.

Oval bedside table with drawer. External frame in shaped MDF lacquered with polished finish (RAL/NCS colours), drawer and top edge covered in contrasting leather or fabric. Built-in top in polished marble. Drawer with damped hinges.

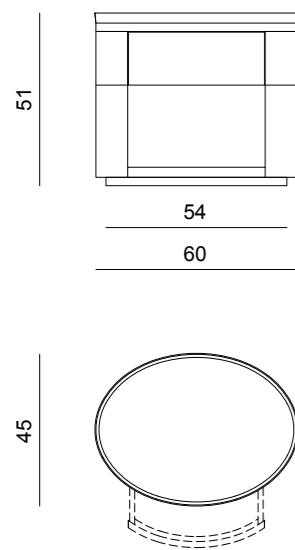

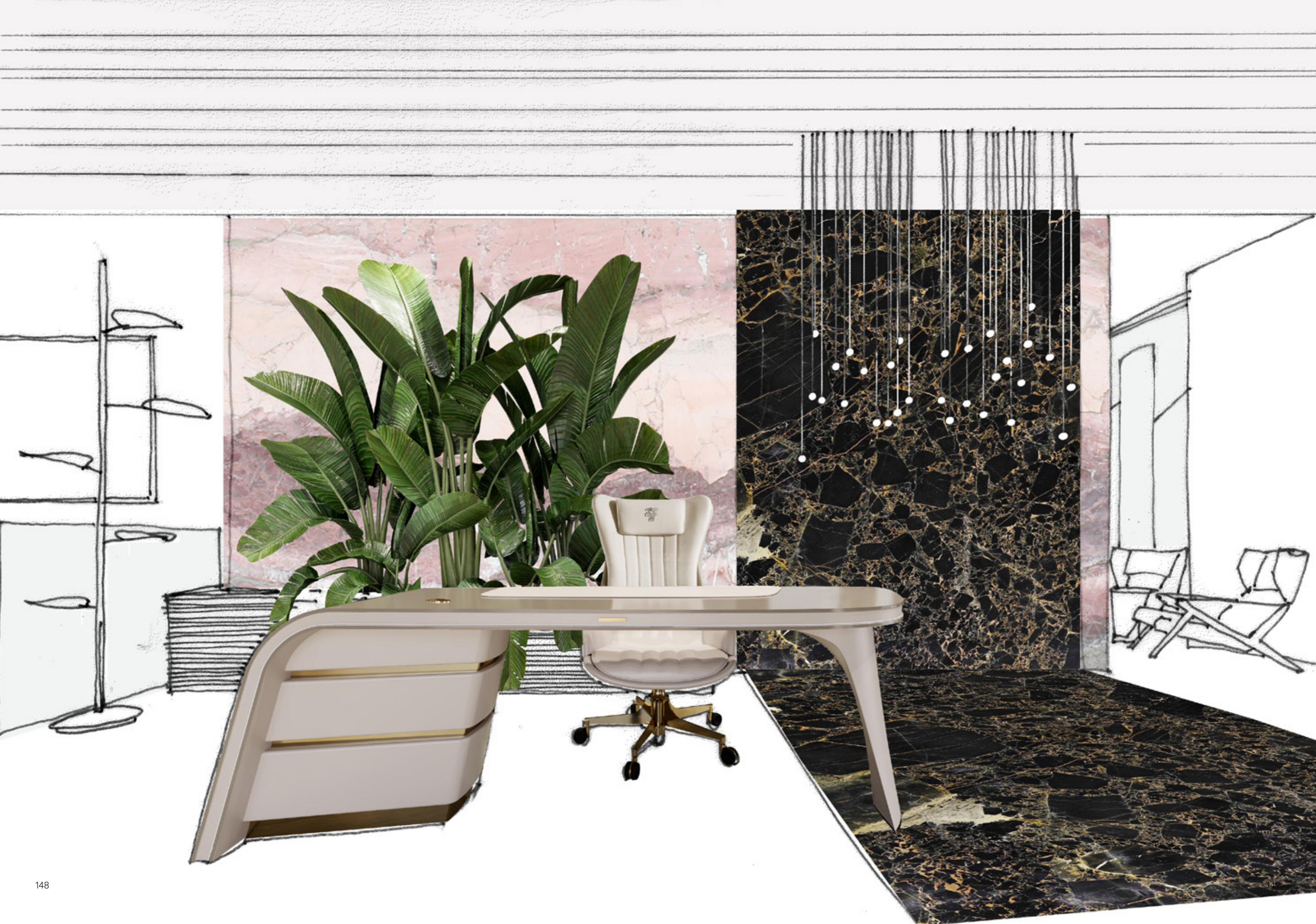









AMBASSADOR
writing desk



Soft leather 1280 argilla



NCS S 5005-Y50R

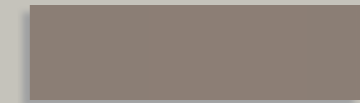

Satinized champagne



AMBASSADOR

229x70 H.75 cm

Main structure in wood upholstered in Soft leather 1280 argilla. Top in lacquered wood in NCS S 5005-Y50R with polished finish. Metal profiles with satinized champagne finish.

● [click here](#)

Soft leather 1280 argilla



Polished lacquer Metal Anthrax

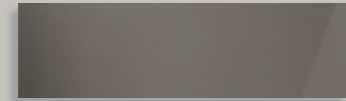

Satinized champagne



AMBASSADOR

229x70 H.75 cm

Main structure in wood upholstered in Soft leather 1280 argilla. Top in lacquered wood in Metal Anthrax colour with polished finish. Metal profiles with satinized champagne finish.

AMBASSADOR

technical drawings

Scrivania
Writing desk

Design
La Conca

Scrivania in legno laccato e pelle. Scocca in multistrati e MDF laccato lucido, top curvato e sagomato laccato lucido (colori RAL), con bordo ad alto spessore e bordo in pelle. Sottomano in pelle con fondo in salpa e velluto, con logo ricamato. Gamba laterale in legno rivestito in pelle e passacavo interno per il passaggio di cavi e cablaggi. Cassettiera integrata con pannelli rivestiti in pelle. Zoccolo di appoggio e profili decorativi in acciaio inox satinato. Le parti metalliche sono disponibili nella selezione finiture metalliche satinato.

Writing desk in lacquered wood and leather. External structure in plywood and MDF with polished lacquer, curved and shaped top with polished lacquer (RAL colours) with thick edge and leather profile. Pad in leather with bottom in salpa bonded leather and velvet and decorated with embroidered logo. Side leg in wood upholstered in leather and internal cable passage for wiring and cables. Integated chest of drawers with panels covered in leather. Plinth and decorative profiles in satin stainless steel. Metal parts available with satin metal lacquered finish.

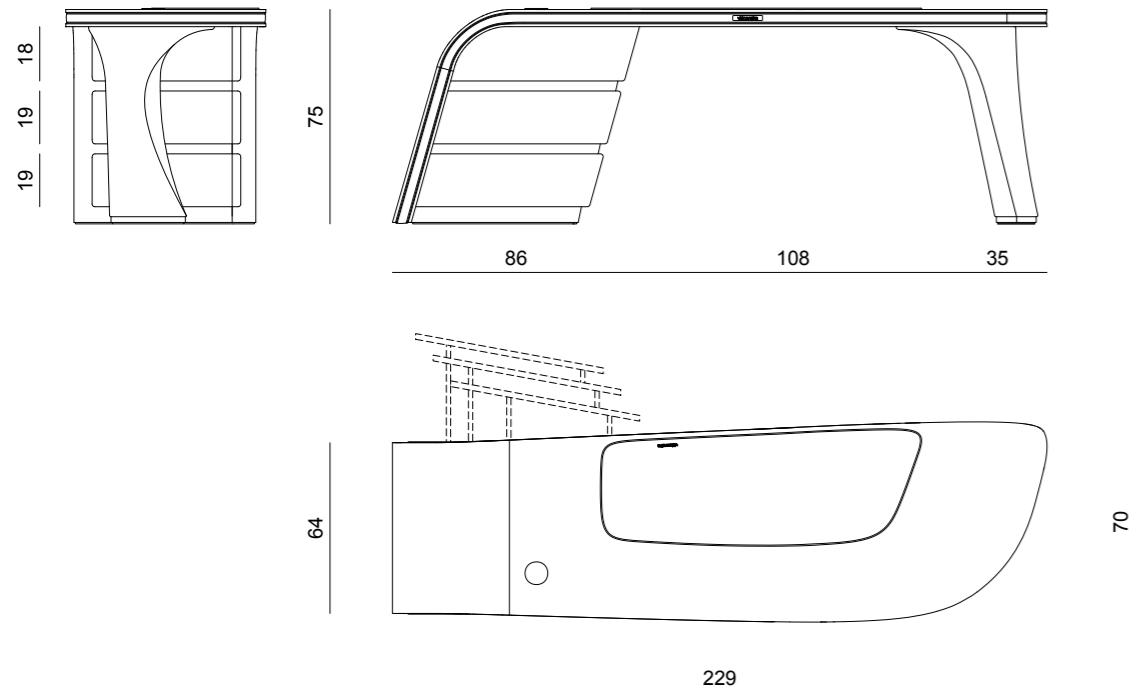





SEKTOR
office armchair



Eco-skin 24327/35 creta



Faber 24229/35 platino



Satinized champagne

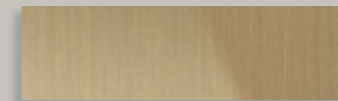

SEKTOR

63x82 H.118 cm

Upholstery in Soft leather 1280 argilla with back in Eco-skin 24327/35 creta. Rotating base in stainless steel with 5-spokes wheels in satinized champagne.

● [click here](#)

SEKTOR

technical drawings

Poltrona girevole
Swivel armchair

Design
La Conca

Poltrona da ufficio in pelle o tessuto. Scocca in multistrati di legno curvato e sagomato a spessore sottile, con rivestimento duotone con possibilità di abbinare pelle e/o tessuto. Nella versione in pelle, la parte interna dello schienale ha una lavorazione trapuntata e traforata a fasce verticali imbottite. Poggiatesta con logo ricamato. Base in acciaio inox girevole a 5 razze con ruote, regolazione in altezza con pistone a gas. Ruote ad alta scorrevolezza con battistrada antigraffio. Le parti metalliche sono disponibili nella selezione finiture metalliche.

Office armchair in leather or fabric. External structure in curved plywood with thin thickness, duotone upholstery available also in matching leather and/or fabric. If upholstered in leather, the internal part of the backrest is quilted in vertical padded strips decorated with a perforated pattern. Headrest with embroidered logo. Rotating base in stainless steel with 5-spokes wheels, adjustable in height. Ergo-glide wheels with antiscratch tread. Metal parts available with polished and satin lacquered finish.

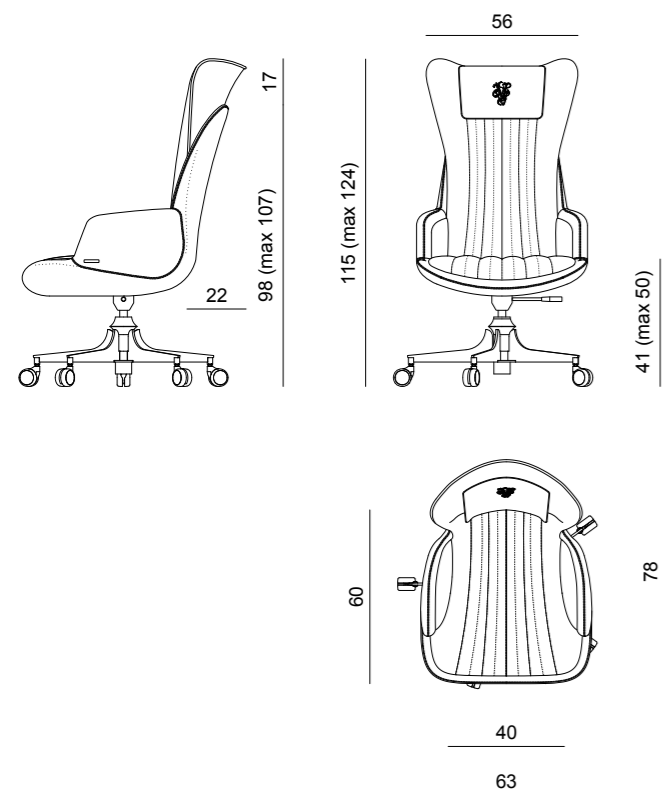







MILLER
sofa







Chamolè 24331/01 Avorio

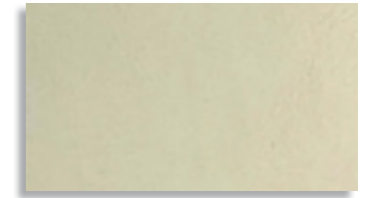

Faber 24229/35 platino



Satinized black nickel



MILLER

253x503 H.85 cm

Main upholstery in leather Chamolè 24331/01 Avorio. Cannetè back structure in fabric Faber 24229/35 platino. Headrest rolls in quilted fabric Faber 24229/35 platino. Loose cushion cm 35x35 in Bansky 24319/15 Foresta. Profiles in black nickel satinized lacquered steel finishing.

● [click here](#)



MILLER

276x105 H.85 cm

Sofa upholstered in fabric Vegas 24316/16 Platino. Back cushions upholstered in velvet Vermeer 24175/17 Ardesia with cannetté quilting. Loose cushions 35x35 cm in velvet Vermeer 24175/111 Peltro. Steel profile with satinized Black nickel satinized finish.

● [click here](#)

Vegas 24316/16 platino



Vermeer 24175/17 ardesia

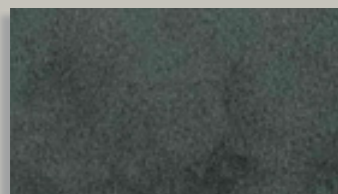

Satinized black nickel



MILLER
unicum sofa



Lawrence 24313/16 beola



Lawrence 24313/17 silver



Gold lacquered steel



MILLER

200x90 H.85 cm

Sofa upholstered in fabric Lawrence 24313/17 Silver. Curved back cushion upholstered in fabric Lawrence 24313/16 Beola with cannetté quilting. Loose cushions 40x40 cm in fabric Lawrence 24313/17 Silver. Steel profile with polished gold-lacquered finish.

● [click here](#)

MILLER

technical drawings

Divano, elementi componibili, poltrona, chaise-longue, pouf
 Sofa, modular elements, armchair, chaise-longue, pouf

Design
 Fabio Bonfà

Divano tappezzato in pelle o tessuto, con fusto in legno massello dotato di cinghie elastiche. Cuscini di seduta in poliuretano a densità differenziate, Memory Foam® e piuma. Cuscini di schienale in poliuretano e piuma, muniti di rullo poggiatesta posteriore. Fianchi e schienale sono rivestiti esternamente in tessuto Gand, Faber o Vermeer trapuntato "canneté". Cuscini volanti in piuma. Versione componibile disponibile con elementi centrali, angolari e laterali. Profilo di base in alluminio disponibile nei colori cromo lucido, oro lucido e nichel nero satinato.

Sofa upholstered in leather or fabric, with base consisting of a frame in wood with elastic spring belts. Seat cushion in polyurethane foam with different densities, Memory Foam® and feather. Back cushions in polyurethane and feather, equipped with headrest rolls. Back and sides in curved wood upholstered in Gand, Faber or Vermeer fabric with quilted canneté motif. Loose cushions in feather. Modular version includes central, corner and lateral elements. Base profile in aluminium available with polish chrome, polish gold or satin black nickel finish.

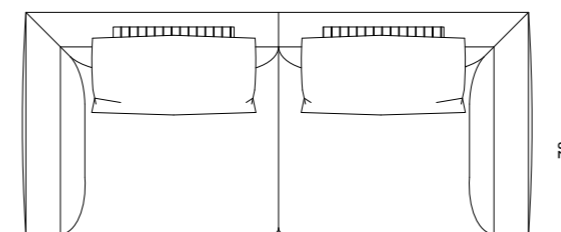
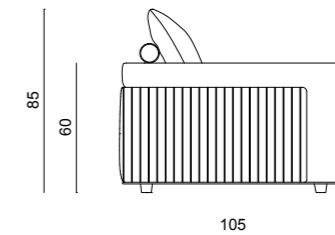
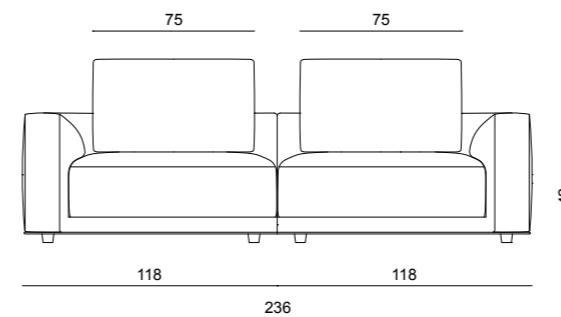
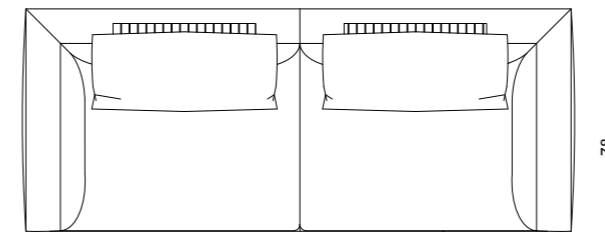
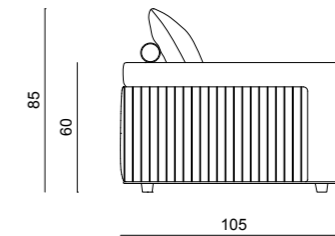
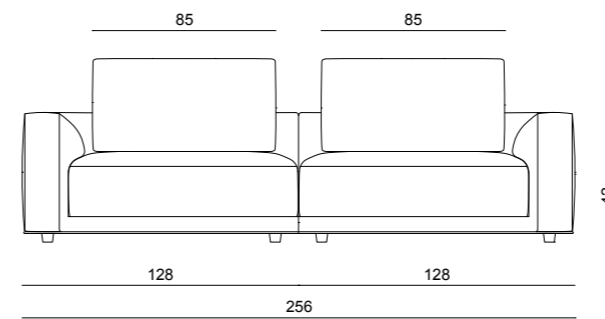
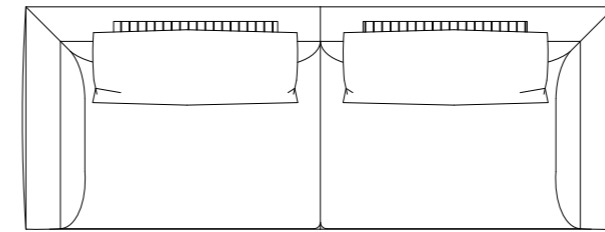
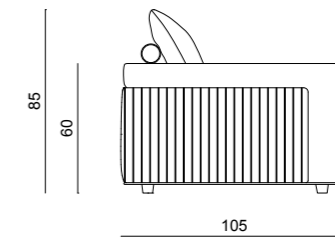
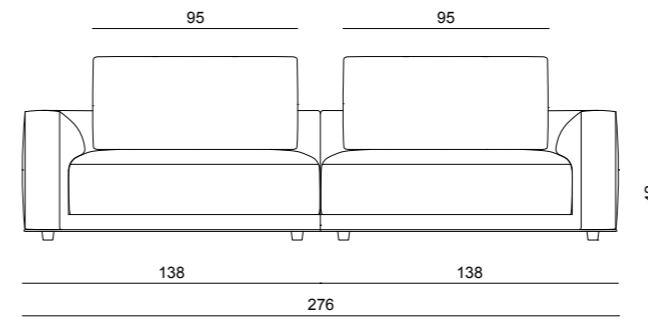
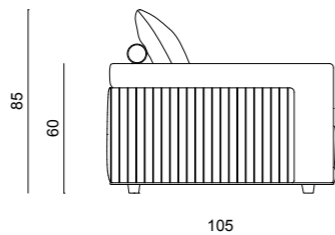
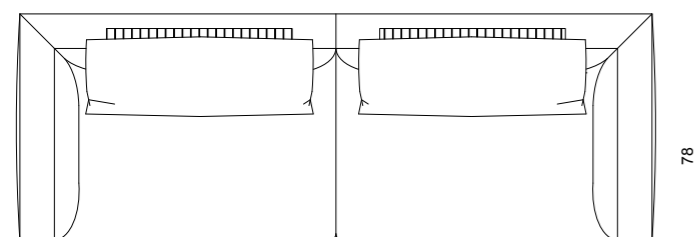
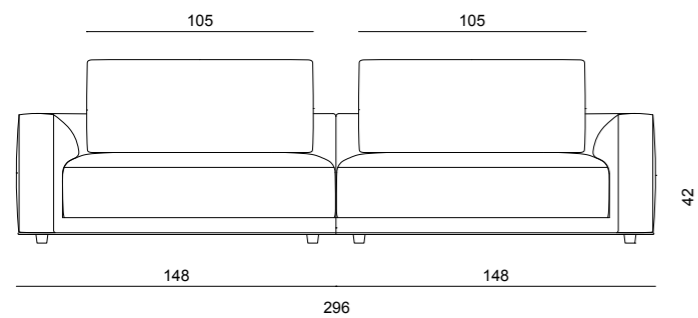
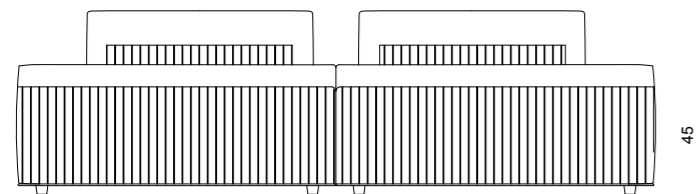

Left lateral element

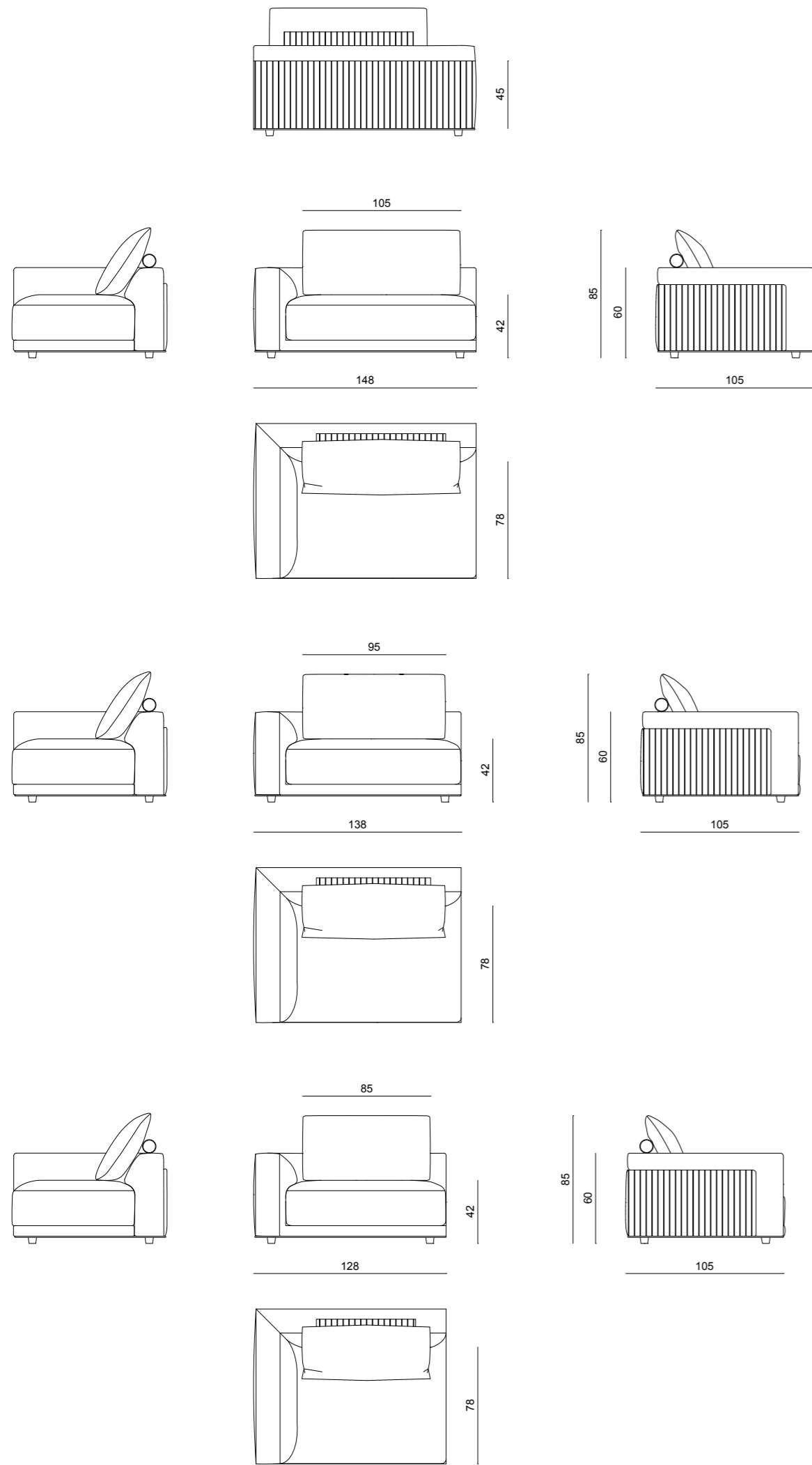

Right lateral element

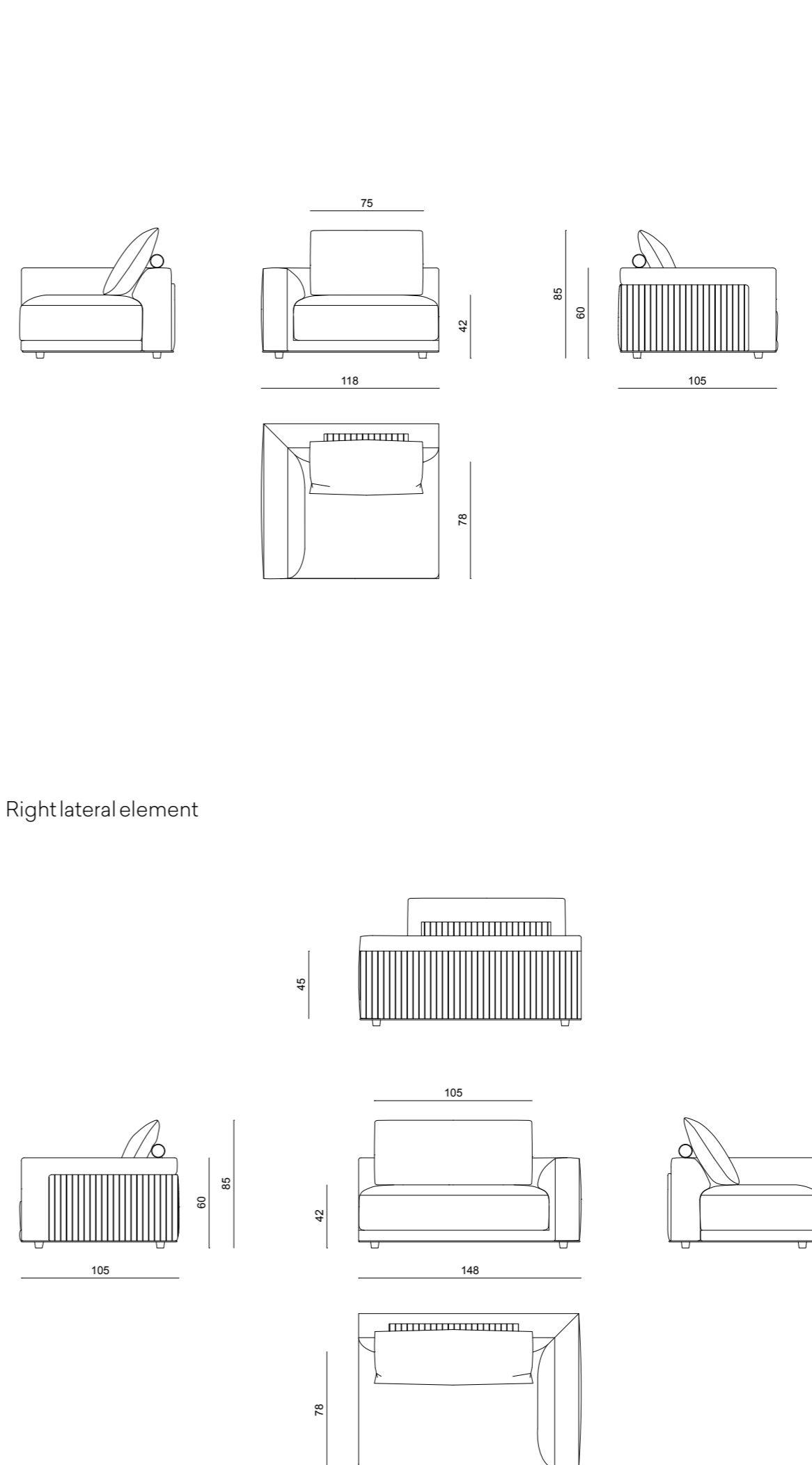

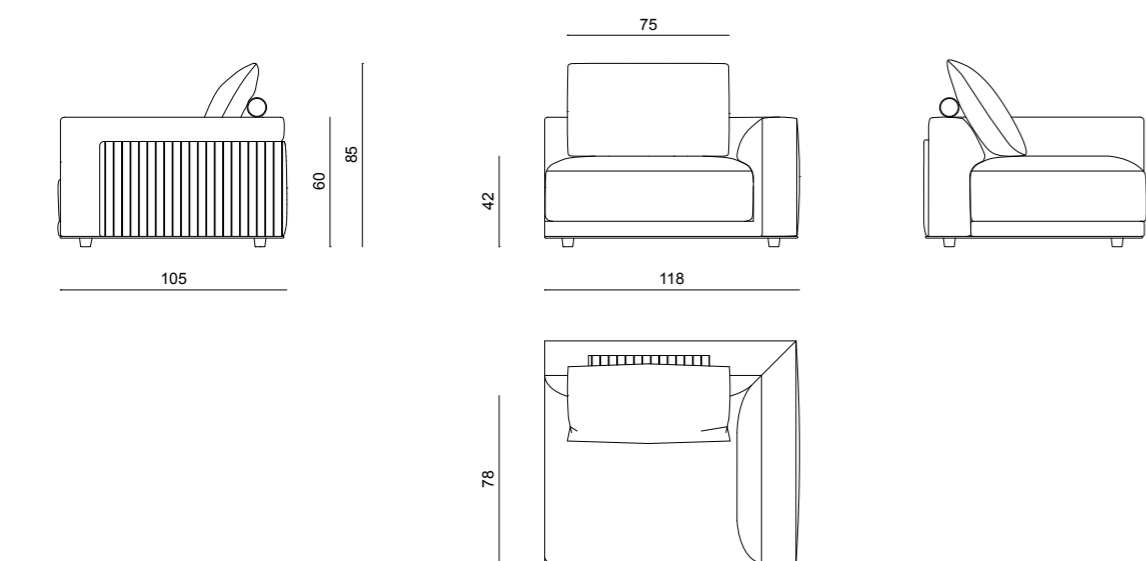
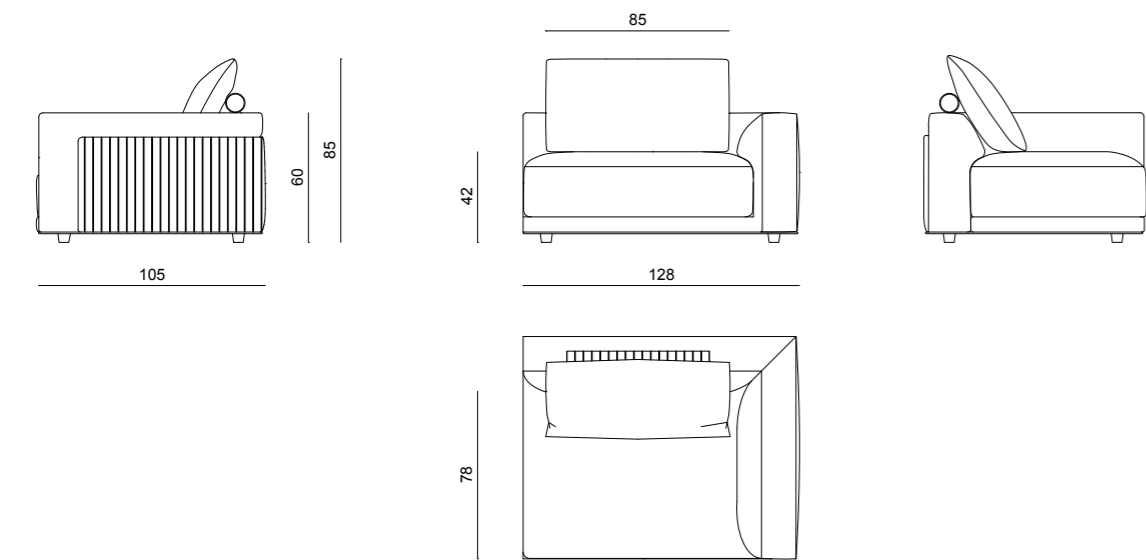
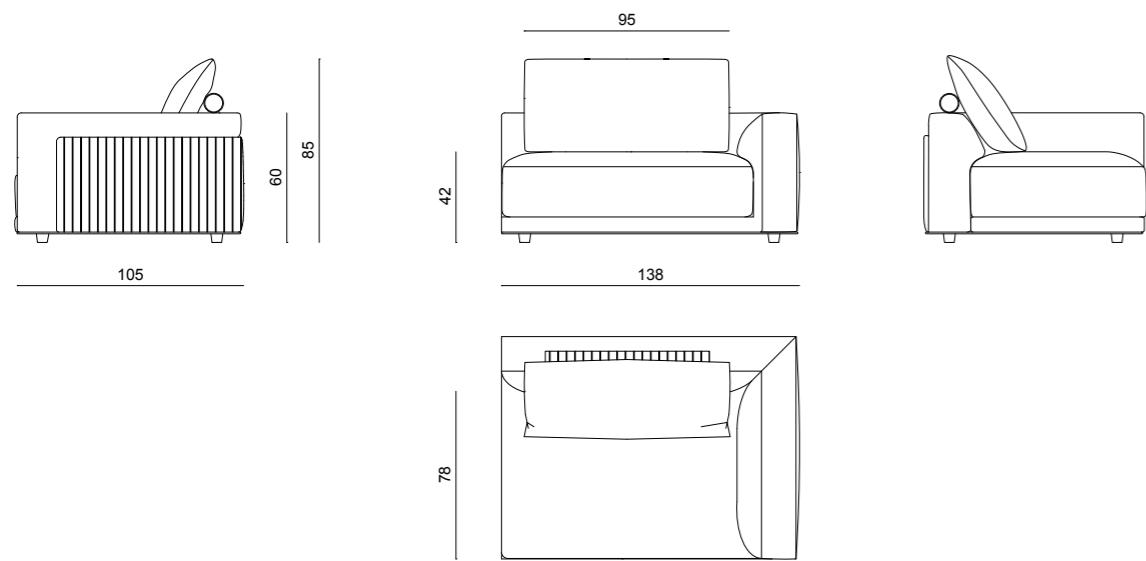

Central element

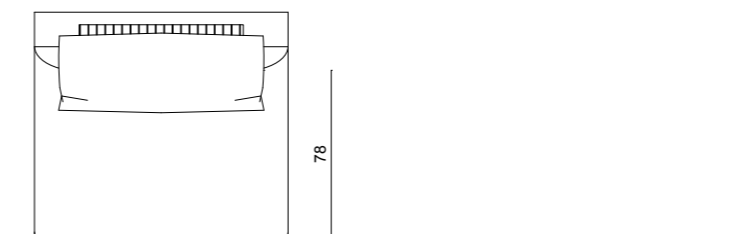
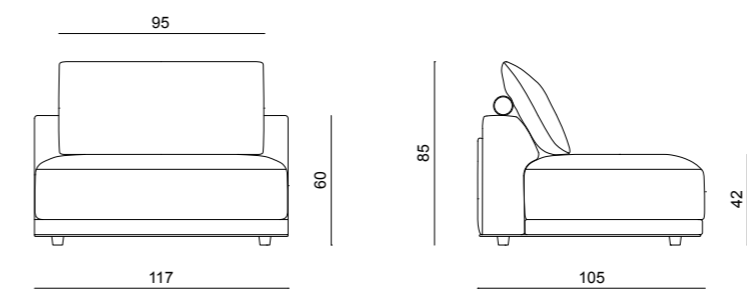
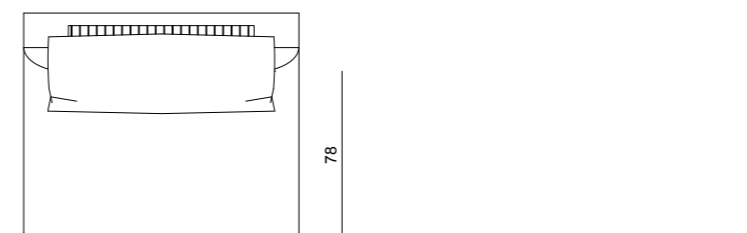
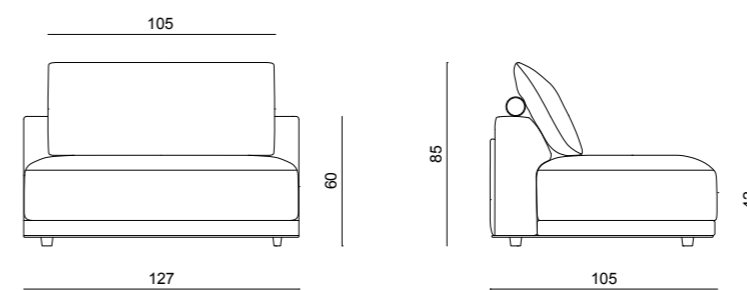
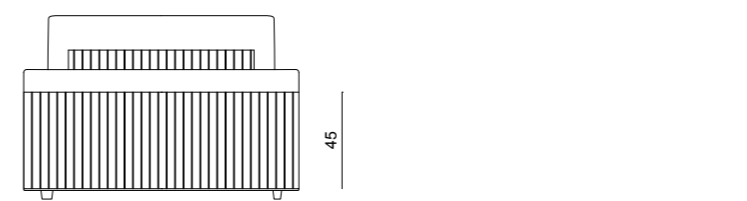

Armrest

Loose cushion

Unicum sofa

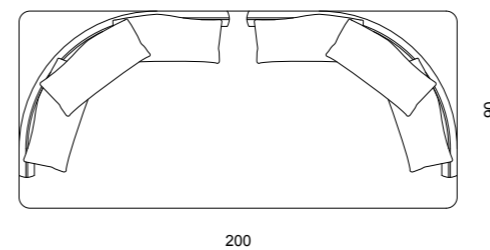
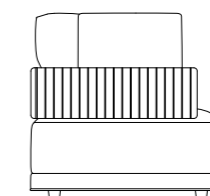
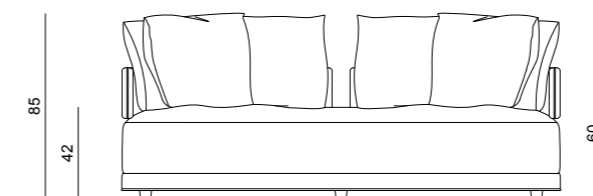
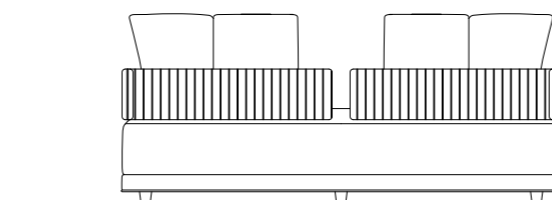
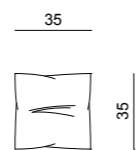
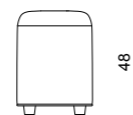
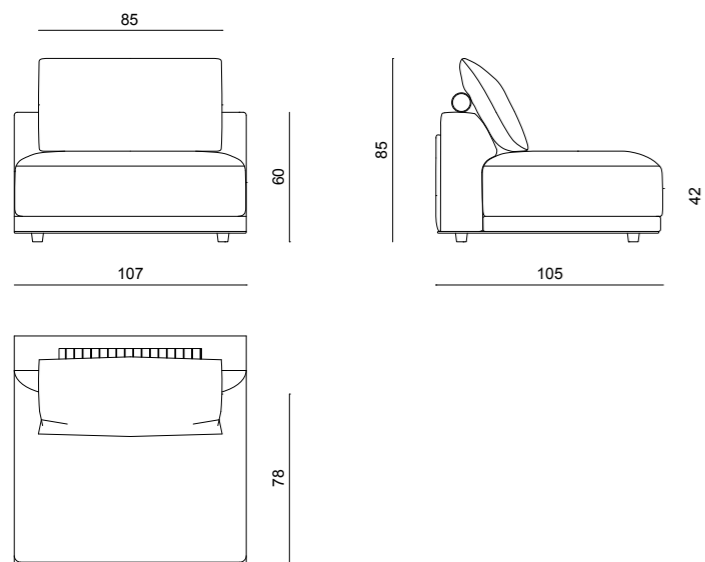

Pouf

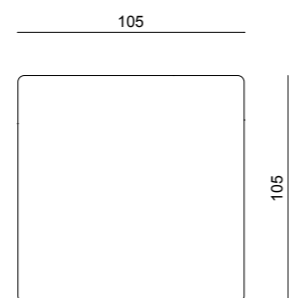
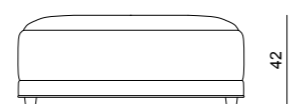
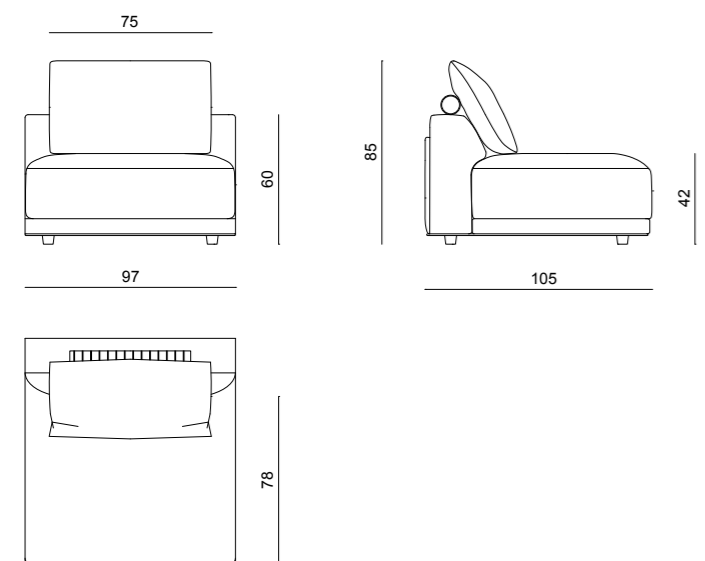

Left chaise-longue

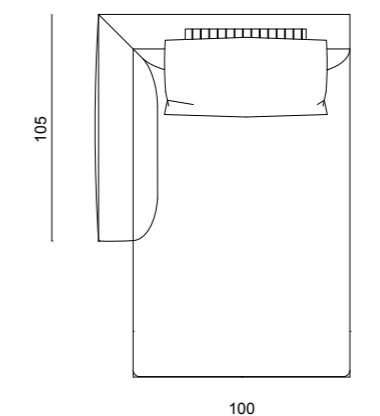
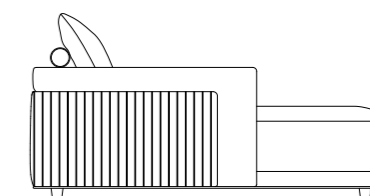
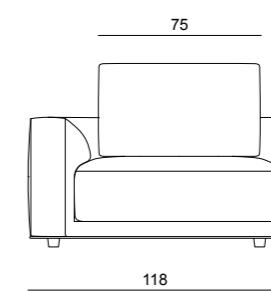
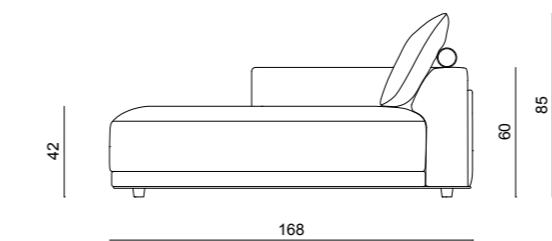
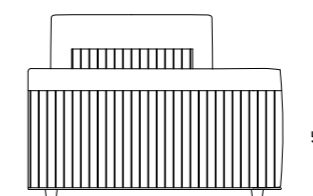
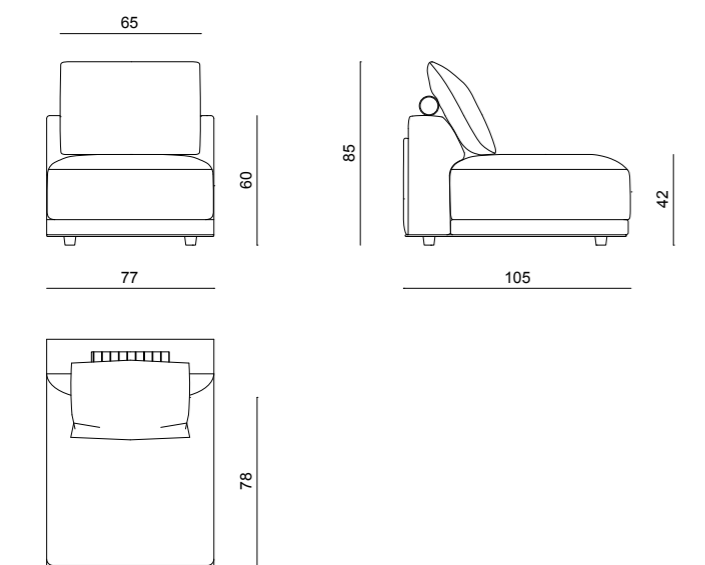

Right chaise-longue

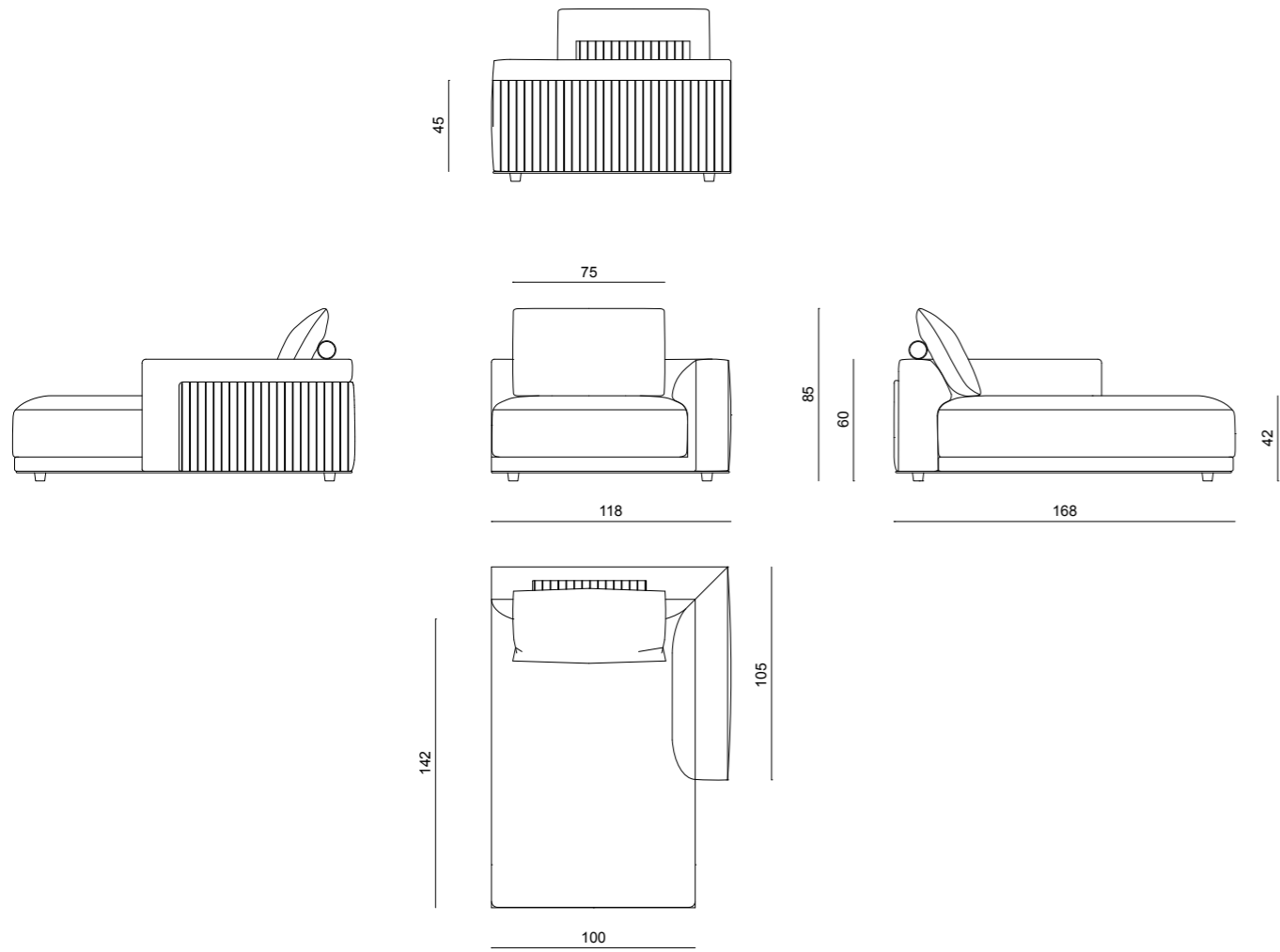

Left lateral curved element

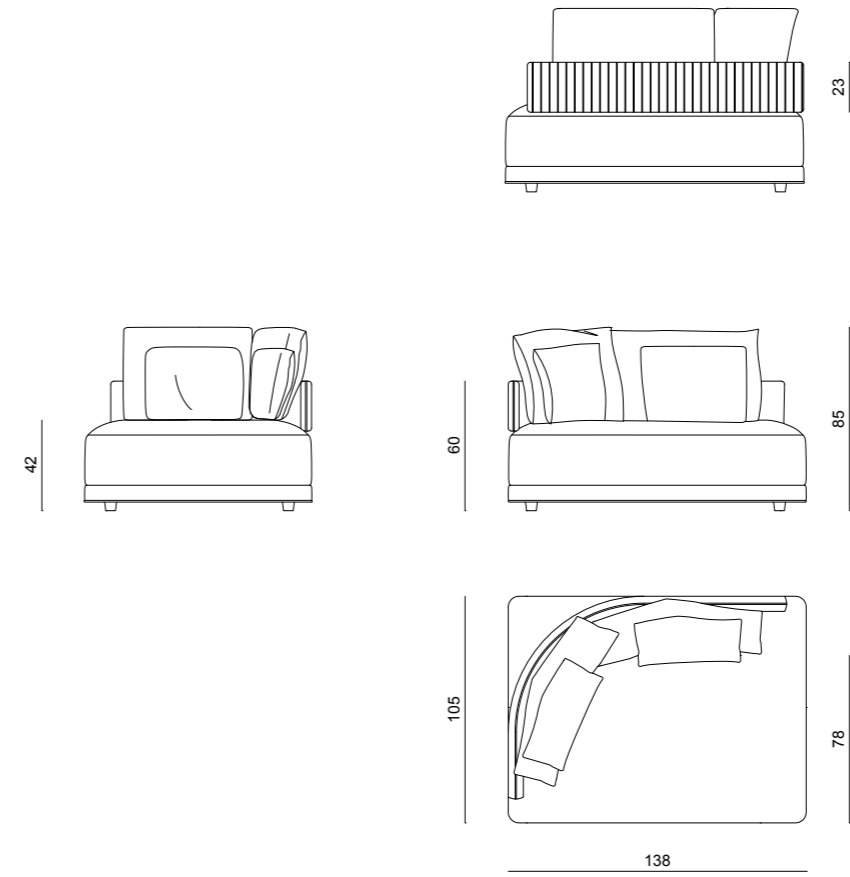

Armchair

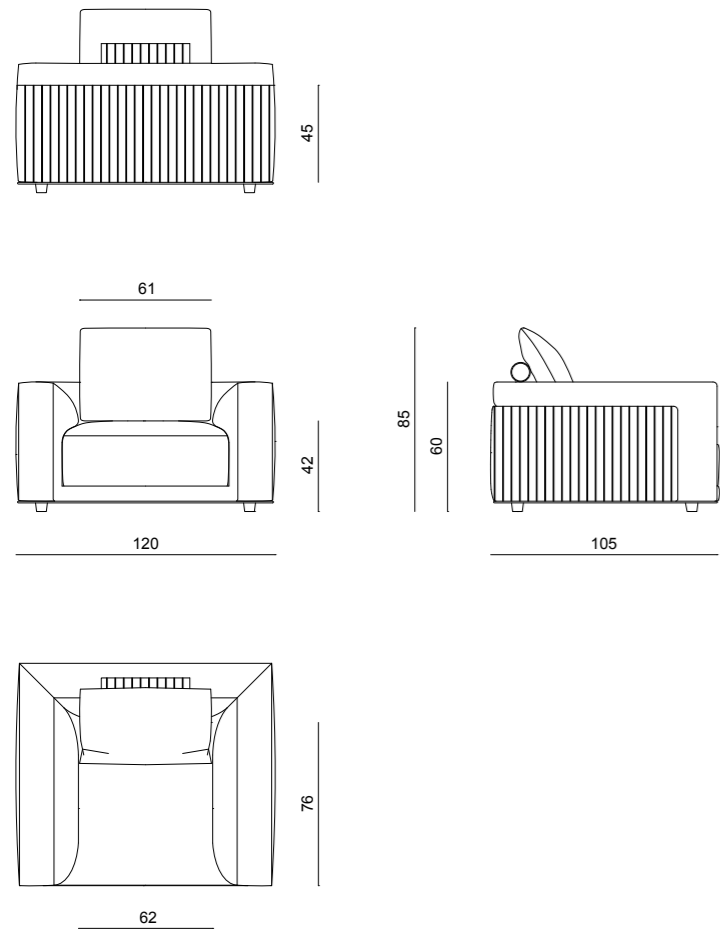

Right lateral curved element

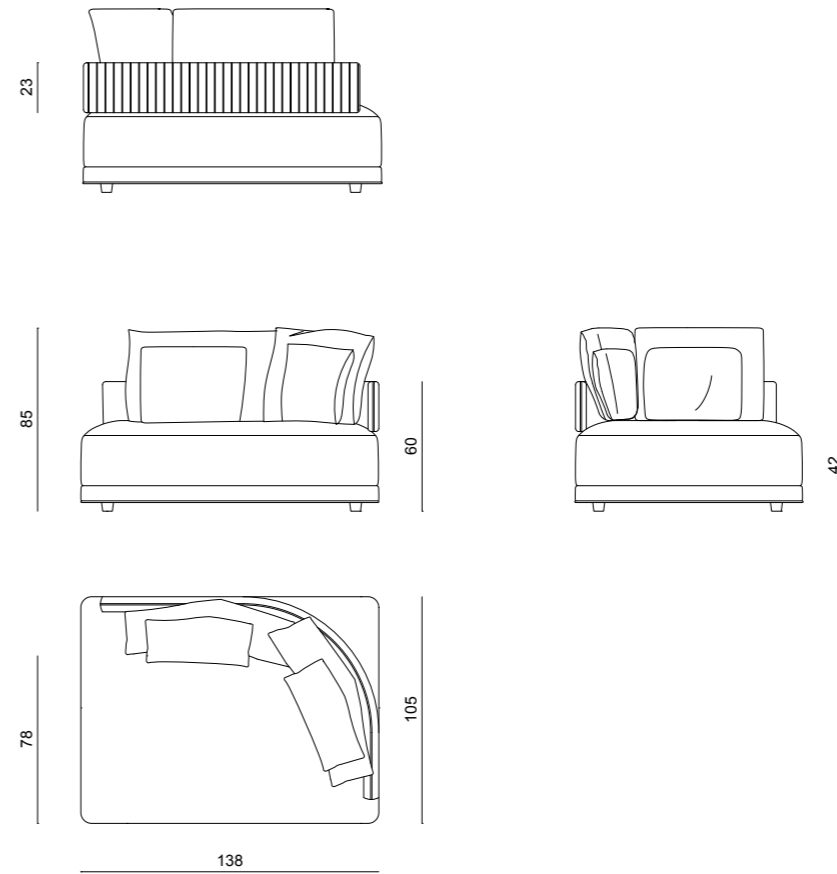



MILLER
low table



MILLER

100x100 H.31 cm - Ø 75 H.37 cm

Top in Calacatta/Verde Saint Denis marble. Wooden structure upholstered in Faber 24229/35 platino. Undertop and plinth in matt black lacquered finishing. Metals and details in black nickel satinized lacquered finishing.

● [click here](#)

Calacatta/Verde Saint Denis marble

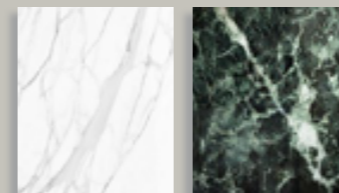

Faber 24229/35 platino



Satinized black nickel



MILLER

technical drawings

Tavolo basso
Low table

Design
Fabio Bonfà

Tavolo basso con top in marmo bicolore e bordo smussato. Base in legno rivestita in tessuto Gand, Faber o Vermeer trapuntato "canneté", profili metallici e fibbia con logo in metallo disponibili nei colori cromo lucido, oro lucido e nichel nero satinato.

Low table with bicolour marble top with rounded edges. Base in wood covered with Gand, Faber or Vermeer fabric quilted with canneté decorative motif. Metal profiles and buckle with metal logo available with polish chrome, polish gold or satin black nickel finish.

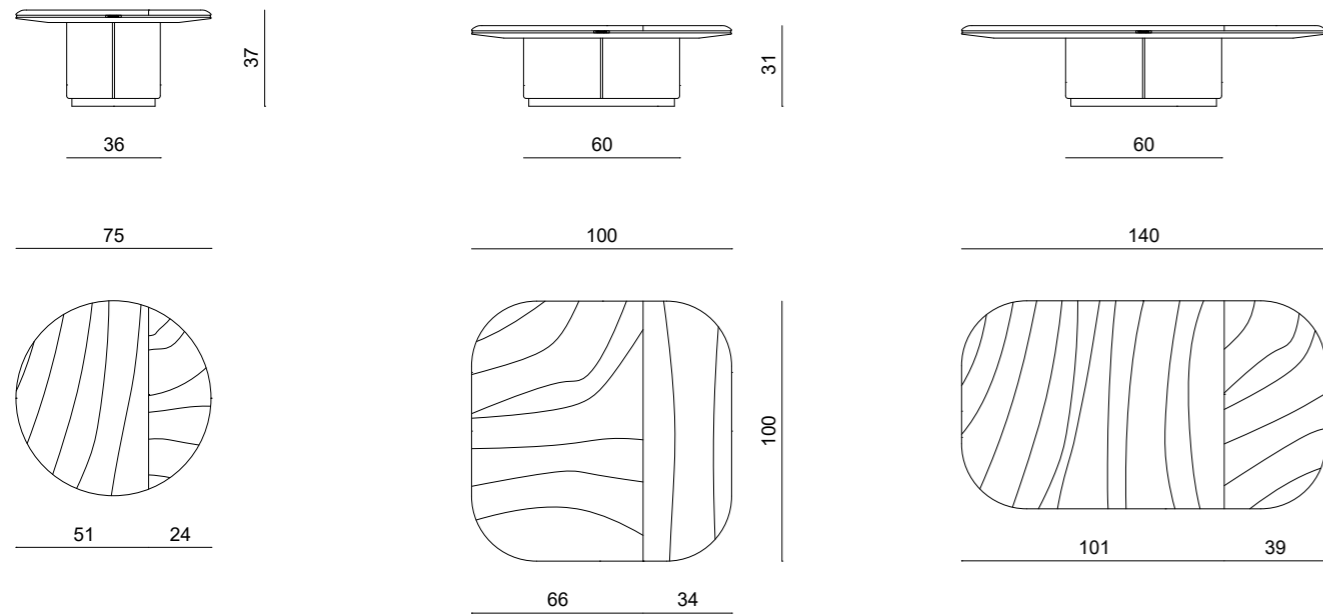



1959-2019
IPE VISIONNAIRE
ANNIVERSARY



Produced by
©IPE SRL
ALL RIGHTS RESERVED

Visionnaire Logo, catalogue and advertising images are sole propriety of IPE srl, henceforth any use of the logo or adaptation of images is strictly forbidden without IPE srl prior approval; nonetheless, in any case the images must be used in such a way that there is no reasonable doubt that those belong to IPE srl and refer to IPE srl products. No part of this publication can be reproduced or transmitted in any form or by any means, both electronic or mechanical, including photocopying and recording, or via any information storage and retrieval system, without written permission of the publisher.

Made in Italy | April 2022

Art Director Eleonore Cavalli

Creatività, sostenibilità e meta-luxury.
La Re-Evolution dal cuore verde di Visionnaire passa anche dalla realizzazione di questo catalogo che unisce il valore storico dell'italianità del brand alla green consciousness. L'intero catalogo è stampato su carte ricavate da fonti gestite in maniera responsabile.

*Creativity, sustainability and meta-luxury.
Visionnaire green-hearted re-evolution hits also the production of this catalogue, in which the long standing value of the company for made-in-Italy melts with the concept of green consciousness. The catalogue is printed on paper obtained from responsibly managed sources.*

AWARDS

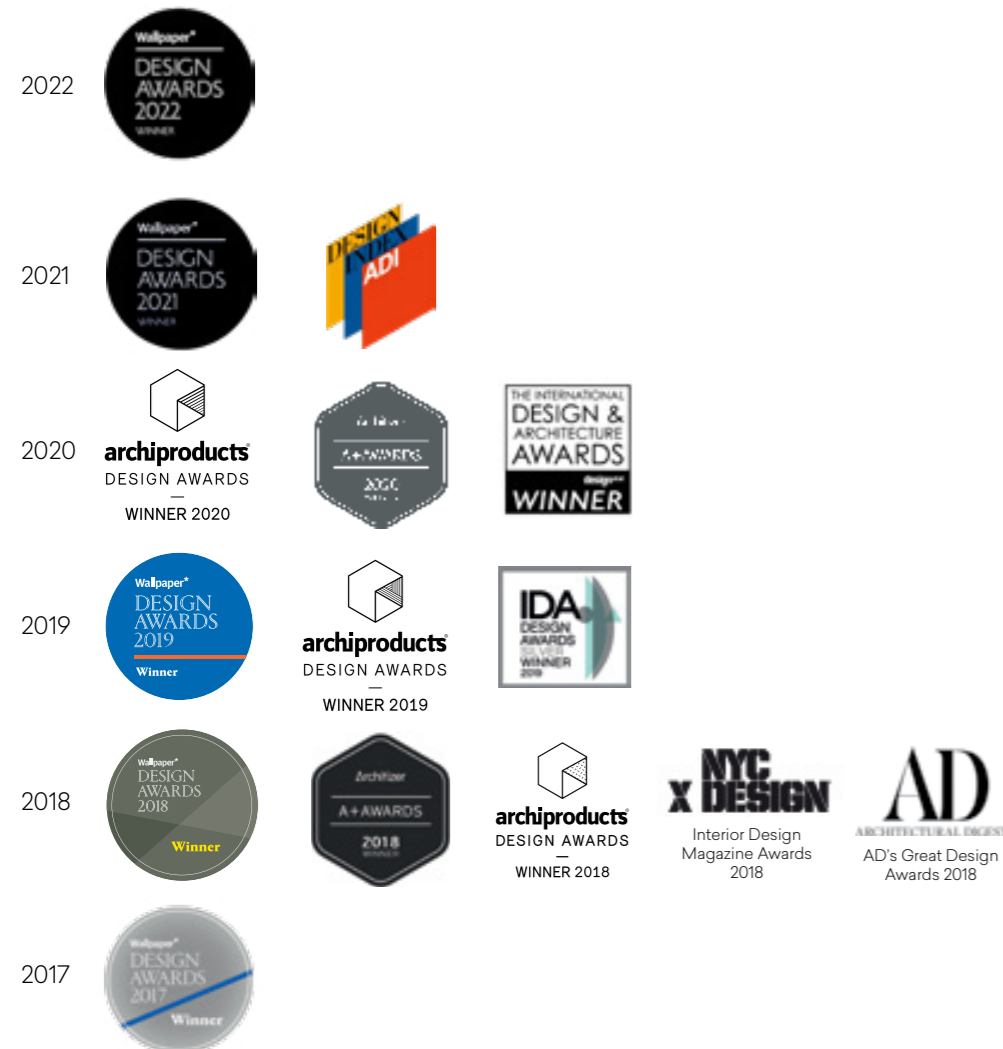

I.P.E. S.r.l.
Via Mattei 1 - 40069 Zola Predosa (Bo) Italy
tel. +39 051 6186311 - fax +39 051 6186310
www.visionnaire-home.com
ipe@ipe.it

Certificazioni relative a I.P.E. S.r.l.



Prodotti certificati FSC® su richiesta

