



HOME PHILOSOPHY
visionnaire

TIMELESS 2022



■ HOME PHILOSOPHY ■
visionnaire



AWARDS

COMPANY PROFILE

Visionnaire, fondato dalla casa madre IPE con sede a Bologna dal 1959, è un brand meta-lusso di riferimento nel settore dell'interior design Made in Italy, amato per la capacità progettuale one-of-a-kind cucita sui desideri dei propri clienti. Il brand opera in più di 55 paesi con una presenza di oltre 30 store monomarca e una rete di department store e multimarca in tutto il mondo. Dal 2004 Visionnaire ha dato vita ad uno stile distintivo, caratterizzato da una vivace sperimentazione sui materiali, volumi dall'equilibrio inaspettato e motivi inconfondibili che celebrano le origini tutte italiane della maison. Grazie alla collaborazione di un team di designer eclettici e visionari, italiani e stranieri, si pone come partner ideale per proposte di bespoke in contesti residenziali e contract, nell'hotellerie di lusso così come nel settore yachting ed aviazione. Il brand basa la propria attività sul valore della conoscenza e la continua ricerca del concetto di bellezza contemporanea, si conferma come artefice di progetti e prodotti di design di altissima sartoria, incentivando e valorizzando le produzioni delle maestranze artigianali locali, presenti sul territorio italiano.

Società Benefit dal 2021, Visionnaire definisce il proprio business come promotore di valore positivo per la comunità ed intende perseguire, nell'esercizio dell'attività economica, uno o più effetti positivi - o ridurre gli effetti negativi - nei confronti di persone, comunità, territori ed ambiente.



Visionnaire, founded by the company IPE, based in Bologna since 1959, is a meta-luxury brand of reference in the sector of interior design Made in Italy, renowned for its one-of-a-kind design prowess tailored to respond to the desires of its clients. The brand operates in over 55 countries, thanks to over 30 exclusive monobrand stores and a network of department store and multibrand showrooms all over the world. Since 2004 Visionnaire has formulated a distinctive style, based on lively experimentation on materials, volumes of unexpected poise and inimitable motifs that reveal the totally Italian background of the company. Thanks to collaboration with a team of eclectic, visionary Italian and foreign designers, the company is an ideal partner for bespoke proposals in residential and contract applications, luxury hotellerie, as well as the yachting and aviation sectors. The brand bases its activity on the value of knowledge and continuing research on the concept of contemporary beauty, confirming its exceptional ability to create design projects and products of outstanding sartorial workmanship, fostering and restoring value to the skills of local artisans located across the Italian territory.

Benefit company from 2021, Visionnaire defines its business as a promoter of positive value for the community and intends to pursue, in the exercise of economic activity, one or more positive effects - or reduce negative effects - towards people, communities, territories and environment.

Il brand, che si pone oggi come manifesto Meta-Luxury, si basa sui valori della conoscenza e la ricerca di atemporalità che vanno a sommarsi per raggiungere un risultato unico nel suo genere. Questo lusso dei contenuti e dei valori trova applicazione nell'uso responsabile dei materiali, in una ricerca tecnologica che l'azienda porta avanti con impegno, in investimenti di efficientamento della catena produttiva e della qualità della vita dei propri artigiani. La convergenza tra benessere del singolo individuo e dell'intero ecosistema che lo ospita si pone al centro della riflessione di Visionnaire all'alba di una nuova decade di necessaria presa di coscienza ambientale e sociale. Benessere e sostenibilità si traducono anche in scelta di tessuti e pelli innovative performanti, che attraverso logiche di riciclo e processo produttivo a basso impatto, rappresentano un nuovo traguardo tecnologico e sostenibile.

Nel 2019 Visionnaire ha ottenuto le certificazioni FSC® Forest Stewardship council® C147146 e PEFC™ Programme for Endorsement of Forest Certification, impegnandosi ad orientare i propri clienti verso una gestione responsabile del patrimonio forestale e la volontà di garantire che i legni utilizzati provengano da tagli legali e da filiere certificate. Visionnaire inoltre certificata ISO 9001 dal 2011, a garanzia del rispetto degli standard qualitativi di gestione, in un più ampio progetto di sviluppo e valorizzazione del saper fare italiano, che si basa sulla scelta di realizzare le produzioni interamente nel nostro territorio, da sessanta anni.

META-LUXURY

The brand, which stands today as a Meta-Luxury manifesto, is based on the values of knowledge and research of timelessness that add up to achieve a unique result of its kind. This luxury of contents and values finds application in the responsible use of materials, in a technological research that the company carries out with commitment, in investments to make the production chain more efficient and the quality of life of its artisans. The convergence between the well-being of the individual and the entire ecosystem that hosts it arises at the center of Visionnaire's reflection at the dawn of a new decade of necessary environmental and social awareness. Wellness and sustainability also translate into the choice of innovative performing fabrics and leathers through recycling logics and a low impact production process, they represent a new technological and sustainable milestone.

In 2019 Visionnaire obtained the FSC® Forest Stewardship council® C147146 certification and the PEFC™ Program for Endorsement of Forest Certification, which demonstrates its commitment to achievement of the global objective of directing the market towards responsible management of forest heritage and the desire to ensure that the woods used come from legal cuts and certified supply chains. Visionnaire has also been ISO 9001 certified since 2011, to guarantee compliance with the quality standards of management, in a wider project of development and enhancement of Italian know-how, which is based on the choice to produce productions entirely in Italy, for sixty years.

Visionnaire prosegue il suo percorso di sviluppo sostenibile, concependo il progetto del catalogo Timeless in un'ottica carbon neutral, tutelando l'ambiente e andando a compensare le emissioni di CO2 prodotte per la sua realizzazione. Le emissioni dirette ed indirette verranno neutralizzate tramite carbon credits (certificati VCS - Verified Carbon Standard) attraverso un progetto rivolto alla tutela della foresta amazzonica brasiliana nell'area di Portel, dentro lo Stato del Parà: è una tipologia di progetto denominato REDD+, acronimo dall'inglese "Reducing emissions from deforestation and forest degradation".

Il Progetto nasce per prevenire la deforestazione delle foreste native, che si è verificata a causa del disboscamento illegale per occupazione abusiva e per tentativi di implementare i pascoli: il coinvolgimento della popolazione locale permette di creare alternative occupazionali legate non alla distruzione quanto alla conservazione del capitale naturale ed alla riqualificazione delle aree forestali degradate.

Visionnaire è seguita in questo percorso da Rete Clima, ente che promuove azioni di Corporate Social Responsibility (CSR), di sostenibilità e di decarbonizzazione, offrendo consulenza alle organizzazioni sensibili alle problematiche ambientali.

CARBON NEUTRALITY

Visionnaire continues along its path of sustainable growth, conceiving the Timeless catalogue in a carbon neutral perspective, protecting the environment and offsetting the CO2 emissions produced by its creation. Direct and indirect emissions will be neutralized with carbon credits (VCS certified - Verified Carbon Standard) through a project aimed at the protection of the Brazilian Amazon forest in the Portel area, within the State of Parà: it is a type of project called REDD +, an acronym from the English "Reducing emissions from deforestation and forest degradation".

The project was created to prevent the deforestation of native forests, which occurred due to illegal deforestation due to illegal occupation and attempts to implement pastures: the involvement of the local population makes it possible to create employment alternatives linked not to destruction but to the conservation of the natural capital natural and the requalification of degraded forest areas.

Visionnaire is followed in this path by Rete Clima, an organization that promotes Corporate Social Responsibility (CSR), sustainability and decarbonisation actions, offering support to companies sensitive to environmental issues.



INDICE

INDEX

| | |
|--|-------|
| DIVANI E POLTRONE <i>SOFAS AND ARMCHAIRS</i> | p.10 |
| POLTRONE SINGOLE <i>SINGLE ARMCHAIRS</i> | p.78 |
| CHAISE-LONGUES, TURCHE <i>CHAISE-LONGUES, OTTOMANS</i> | p.96 |
| PANCHE, POUF <i>BENCHES, POUFFES</i> | p.106 |
| SEDIE, SGABELLI, SEDIE DA UFFICIO <i>CHAIRS, STOOLS, OFFICE CHAIRS</i> | p.122 |
| LETTI <i>BEDS</i> | p.150 |
| COMODINI <i>BEDSIDE TABLES</i> | p.178 |
| TAVOLI DA PRANZO <i>DINING TABLES</i> | p.190 |
| TAVOLI BASSI, TAVOLINI <i>LOW TABLES, SMALL TABLES</i> | p.216 |
| CONSOLLE <i>CONSOLES</i> | p.252 |
| MADIE, MOBILI BASSI <i>CABINETS, LOW UNITS</i> | p.268 |

| | |
|--|-------|
| CASSETTIERE <i>CHEST OF DRAWERS</i> | p.296 |
| MOBILI BAR <i>BAR CABINETS</i> | p.306 |
| MOBILI TRUCCO <i>VANITY UNITS</i> | p.318 |
| SCRIVANIE, MOBILI RECEPTION <i>WRITING DESKS</i> | p.334 |
| LIBRERIE <i>BOOKSHELVES</i> | p.346 |
| ARMADI, PORTABITI <i>WARDROBES, CLOTHES HANGER</i> | p.362 |
| SELEZIONE ESSENZE E FINITURE METALLICHE <i>VENEER AND METAL FINISHES SELECTION</i> ... | p.372 |
| SPECCHI <i>MIRRORS</i> | p.376 |
| LAMPADARI, PLAFONIERE <i>CHANDELIERS, CEILING LAMPS</i> | p.392 |
| APPLIQUES <i>WALL LAMPS</i> | p.414 |
| LAMPADE DA TAVOLO <i>TABLE LAMPS</i> | p.430 |

| | |
|--|-------|
| PIANTANE <i>FLOOR LAMPS</i> | p.448 |
| CACHE-POT <i>CACHE-POT</i> | p.458 |
| TAPPETI <i>CARPETS</i> | p.464 |
| WELLNESS ROOM | p.478 |
| FOODROOM | p.494 |
| DEHORS | p.510 |
| RE-EDITION | p.564 |
| ACCESSORI CONTEMPORARY <i>CONTEMPORARY ACCESSORIES</i> | p.568 |
| ACCESSORI ICONICI <i>ICONIC ACCESSORIES</i> | p.582 |
| ART GALLERY | p.602 |
| ART DESIGN | p.646 |

INFORMAZIONI GENERALI SUI PRODOTTI

I prodotti Visionnaire nascono dalla realizzazione di un'idea tramite tecniche costruttive e di lavorazione derivanti da molteplici settori produttivi strettamente artigianali appartenenti alla tradizione manifatturiera italiana. Le tecnologie impiegate uniscono la tradizione all'avanguardia, conferendo ai nostri prodotti unicità e qualità di livello superiore. L'impiego di materiali e tecniche esclusive, la lavorazione manuale e la filosofia sartoriale della nostra produzione artigianale, conferisce ai prodotti caratteristiche distintive uniche per cui apparenti irregolarità o differenze sono da considerarsi peculiarità che rendono il prodotto unico ed esclusivo.

LEGNO

Le strutture dei mobili sono realizzate a partire da pannelli (multistrati e fibra di legno) finiti con laccature lucide o opache (colori RAL/NCS) oppure impiallacciati in essenza (selezione essenze). Alcune parti di mobili sono in legno massello lavorato e finito con effetto naturale “a poro aperto” o laccato lucido. Per essenze e masselli, l'aspetto ed il colore del legno possono variare leggermente a distanza di tempo e da una fornitura all'altra per via delle differenze naturali del legno stesso.

Gli imbottiti hanno una struttura interna in legno massello e multistrati con molleggio a cinghie elastiche e connessioni in ferramenta.

IL PERCORSO VERSO LO SVILUPPO SOSTENIBILE

Seguendo il proprio impegno verso lo sviluppo sostenibile e una gestione responsabile del patrimonio forestale, Ipe s.r.l - Visionnaire ha ottenuto le certificazioni aziendali FSC™ Forest Stewardship Council™ e PEFC™ Programme for Endorsement of Forest Certification. Per consolidare questo percorso Ipe s.r.l - Visionnaire propone una selezione di prodotti della collezione Anniversary (2019) con certificazione FSC™ e PEFC™ ordinabili su richiesta.

MARMO

Il marmo è un materiale naturale selezionato da Visionnaire per i top di tavoli, tavolini, cucine nonché per parti di mobili in massello di marmo come basamenti, piedistalli, ecc. La finitura superficiale del marmo può essere lucida o lavorata con diverse finiture come “mano leather” e opaca. La lavorazione e la finitura delle parti in marmo unisce l'alta tecnologia alla manualità ed alla cura artigianale sulla finitura di ogni singolo prodotto. L'aspetto ed il colore delle lastre utilizzate possono variare da una fornitura all'altra per via delle differenze naturali nelle venature e nei colori della pietra stessa.

PELLE/CUOIO

Tutte le nostre pelli sono ricavate da bovini accuratamente selezionati. La concia delle nostre pelli enfatizza le qualità dei vari modelli conferendo caratteristiche estetiche, tattili e di comfort uniche. Nel campionario pelli sono presenti materiali uniti, stampati ed intrecciati, ognuno dei quali è lavorato con trattamenti idonei ad enfatizzare le caratteristiche dell'articolo scelto; imperfezioni, cicatrici, diversità di opacità e tonalità sono da considerarsi caratteristiche che rendono unica la pelle.

AZEROCARE zerocare

Azerocare è il primo processo protettivo specifico per il marmo, brevettato da Antolini, ed è la soluzione ideale per gli ambienti bagno e cucina, in quanto garantisce una protezione permanente contro macchie e corrosione dovute al contatto delle superfici con sostanze organiche acide (il cui PH varia da 3 a 8). Questo processo svolge la sua funzione protettiva, mantenendo l'estetica, i colori e la percezione al tatto della pietra naturale. Azerocare è quindi una garanzia contro eventuali danni derivanti dall'utilizzo di prodotti come vino, caffè, olio, aceto, salsa di pomodoro, succhi di frutta, nonché profumi, dentifrici, detersivi, lozioni, rossetti o eau de toilette. Questo processo rende inoltre le superfici non permeabili, evitando la proliferazione di batteri. Questo trattamento è disponibile sui marmi Black & Gold, Dover White e Dalmata per i prodotti: tavolo da pranzo Kerwan, mobile trucco Kobol e consolle lavabo Leonardo, oltre che per produzione di elementi su richiesta.

MANUTENZIONE GENERICA

Tutti i prodotti Visionnaire sono oggetti pregiati e costruiti con materiali esclusivi che vengono rifiniti con vernici, marmi, vetri, essenze caratterizzati da una protezione superficiale che ne preserva le qualità e la durata. Per non danneggiare o deteriorare l'aspetto superficiale dei nostri materiali, si raccomanda una pulizia periodica con panno umido morbido, non abrasivo, evitando in ogni caso l'uso di prodotti aggressivi, solventi, acidi o alcool. In caso di danneggiamento accidentale superficiale, si consiglia di contattare Ipe s.r.l. - Visionnaire per suggerimenti sul ripristino delle superfici. Per i tessuti si rimanda all'etichetta di cura e manutenzione, per le pelli si consiglia di contattare Ipe s.r.l. - Visionnaire per suggerimenti sul ripristino delle superfici tramite appositi kit di pulizia disponibili a richiesta.

ASPETTO DEL PRODOTTO E PROPRIETÀ INTELLETTUALE

Ipe s.r.l. – Visionnaire si riserva il diritto di modificare i propri prodotti senza preavviso. In caso di completamento e combinazione tra prodotti diversi, se non specificato nell'ordine, il prodotto sarà realizzato nella versione attuale alla data dell'ordine. La tonalità e l'aspetto superficiale di pelli, tessuti, essenze lignee, masselli di legno, marmi ed onici possono subire differenze tra una fornitura e l'altra; in caso di abbinamento tra prodotti diversi, è richiesto di specificarlo nell'ordine.

I disegni inclusi nel presente catalogo non definiscono i dettagli del prodotto; le misure mostrate sono indicative e possono subire modifiche senza preavviso.

I diritti di proprietà intellettuale sono di piena ed esclusiva proprietà di Ipe s.r.l. - Visionnaire. Il Cliente si impegna a non compiere alcun atto che possa essere in contrasto con la proprietà industriale di Ipe s.r.l. - Visionnaire, non deve rimuovere o alterare il marchio/logo Visionnaire e deve usarlo esclusivamente in conformità con le istruzioni ricevute da Ipe s.r.l. - Visionnaire.

GENERAL PRODUCT INFORMATION

Our products are the embodiment of ideas realised by using production techniques derived from different sectors of handicraft, belonging to Italian traditional artisanry. These technologies combine tradition with cutting-edge production processes, characterising our products as unique and top-quality. The use of high-end materials and techniques, the craftsmanship and tailor-made philosophy inspiring our handmade production lend on our products those unique features, which make any apparent imperfection or difference an additional distinctive peculiarity.

WOOD

Furniture structures are made from panels (in plywood or wood fibre) finished with a shiny or matt lacquer (RAL/ NCS colours) or with wood veneer (veneered finish selection). Some parts of the furniture are in solid wood, treated and finished with an open-pore natural effect or with a shiny lacquer. Veneer and solid wood may go through subtle colour changes over time and from one consignment of material to another, due to the natural differences characterising wood itself.

Padded furniture has an internal frame in solid wood and plywood with elastic webbing strapsand metal fittings.

A PATH TO SUSTAINABLE DEVELOPMENT

Keeping its commitment to implementation of sustainable development and responsible management of forest heritage, Ipe s.r.l - Visionnaire has obtained the FSC™ Forest Stewardship Council™ certification and PEFC™ Program for Endorsement of Forest Certification. With a view to moving forward on this path, Ipe s.r.l - Visionnaire offers a selection of products from the Anniversary collection (2019) which can be ordered with FSC™ and PEFC™ certificates upon request.

MARBLE

Marble is a natural material selected by Visionnaire for top of tables, low tables, kitchens, other than for parts of furniture made in solid marble, such as ballasts, stands, and so on. Marble can be polished or matt, or it can be treated as to obtain particular finishes, such as “leather-hand” effect. The treatment and finish of marble parts combine high-end technology with craftsmanship and artisan accuracy when finishing each single product. The look and colour of slabs employed may vary from one consignment of material to another, due tot the natural differences in veins and shade of marble itself.

LEATHER/EMERY LEATHER

All our leathers come from carefully selected bovines. The tanning of hides enhances the quality of each model, giving unique aesthetical features, tactile feeling and comfort. The leather sample book includes single-coloured, printed and interwoven materials, which undergo treatment specifically conceived to emphasise the characteristics of the selected product; subtle imperfections, scars, difference in opacity and shade are to be considered signs of the uniqueness of the leather.

AZEROCARE zerocare

Azerocare is the first specific protective process for marble, patented by Antolini, and is the ideal solution for bathroom and kitchen spaces as it guarantees permanent protection against stains and corrosion caused by contact of surfaces with acidic organic substances (whose PH ranges from 3 to 8). This process carries out its protective function, keeping aesthetics, colors and perception to the touch of the natural stone. Azerocare is therefore a guarantee against possible damages deriving from the use of products such as wine, coffee, oil, vinegar, tomato sauce, fruit juices, as well as perfumes, toothpastes, detergents, lotions, lipsticks or eau de toilette. This process also makes surfaces non-permeable, avoiding the proliferation of bacteria. This treatment is available on the Black&Gold, Dover White and Dalmata marbles for the products Kerwan dining table, Kobol wellness unit and Leonardo wellness unit, as well as for the production of elements on request.

GENERAL MAINTENANCE INSTRUCTIONS

All Visionnaire products are valuable items and they are made with high-end materials which are finished with lacquers, marbles, glasses, wood veneers protected by a superficial coating preserving their quality over time. To prevent any damage or deterioration of the look of our materials, we recommend to clean them regularly using a humid soft (no abrasive) cloth, always avoiding the use of aggressive products, solvents, acids or alcohol. In case of accidental damage of a surface, we invite you to contact Ipe s.r.l. - Visionnaire to receive indications of how to restore of the surface. For damaged fabrics, refer to maintenance instructions written on the label; for leather, we invite you to contact Ipe s.r.l - Visionnaire to receive indications of how to restore the leather, using the appropriate cleaning kit available upon request.

PRODUCT LOOK AND INTELLECTUAL PROPERTY

Ipe s.r.l. - Visionnaire reserves the right to change its products without notice. In the event of order completion or combination of different products, unless otherwise specified in the order, products will be made in compliance with the most recent version released at the time of the order. Colour shade and look of leathers, fabrics, wood veneers, solid woods, marbles and onyx stones may change from one consignment of material to another; in the event different products are combined, this information shall be clearly stated in the order.

Drawings included in the catalogue do not represent product details; any dimensions show are indicative only and may be changed without notice.

Intellectual property rights are fully and solely owned by Ipe s.r.l. - Visionnaire. The Client agrees to avoid undertaking any act which may be in contrast with Ipe s.r.l. - Visionnaire intellectual property, he/she shall not remove or change Visionnaire trademark/logo and shall use it solely in compliance with instructions received by Ipe s.r.l - Visionnaire.

- click on the icons -



ANTHEM p.12



ASHTON p.14



BALANCE p.15



BABYLON p.16



BABYLON RACK p.18



BACKSTAGE p.22



BASTIAN DUAL p.24



BASTIAN STILL p.26



BASTIAN LOUNGE p.28



CA' FOSCARI p.30



CAPITOL p.31



CHATAM p.32



CHATAM CURVO p.33



CITIZEN p.34



DENZEL p.35



DEIMOS p.36



DONOVAN ROLL p.38



DONOVAN SQUARE p.40



DOUGLAS p.42



FITZGERALD p.44



FREYR p.45



FOSTER p.46



HAGAL p.48



HEMINGWAY p.49



LEGEND p.50



JAMBOREE p.52



MEMPHIS p.53

- click on the icons -



MONTPARNASSE p.54



MILLER p.56



MILLER UNICUM p.58



PRESENCE p.59



ORLANDO p.60



RHAPSODY p.62



VANITY FAIR p.63



XAVIER p.64

ICONICI - *ICONIC*



AVALON p.66



BERRY p.67



CHESTER DONEY p.68



CHESTER LAURENCE p.69



DIPLOMATE p.70



ENEA p.71



GINEVRA p.72



GINEVRA MODULAR p.73



GINEVRA SHAPED p.74



OBERON p.75



VALANCOURT p.76

RE-EDITION



MERCURY p.566



MERCURY p.567



ANTHEM

DIVANO, ELEMENTI componibili, CHAISE-LONGUE, POLTRONA
SOFA, MODULAR ELEMENTS, CHAISE-LONGUE, ARMCHAIR
Fabio Bonfà

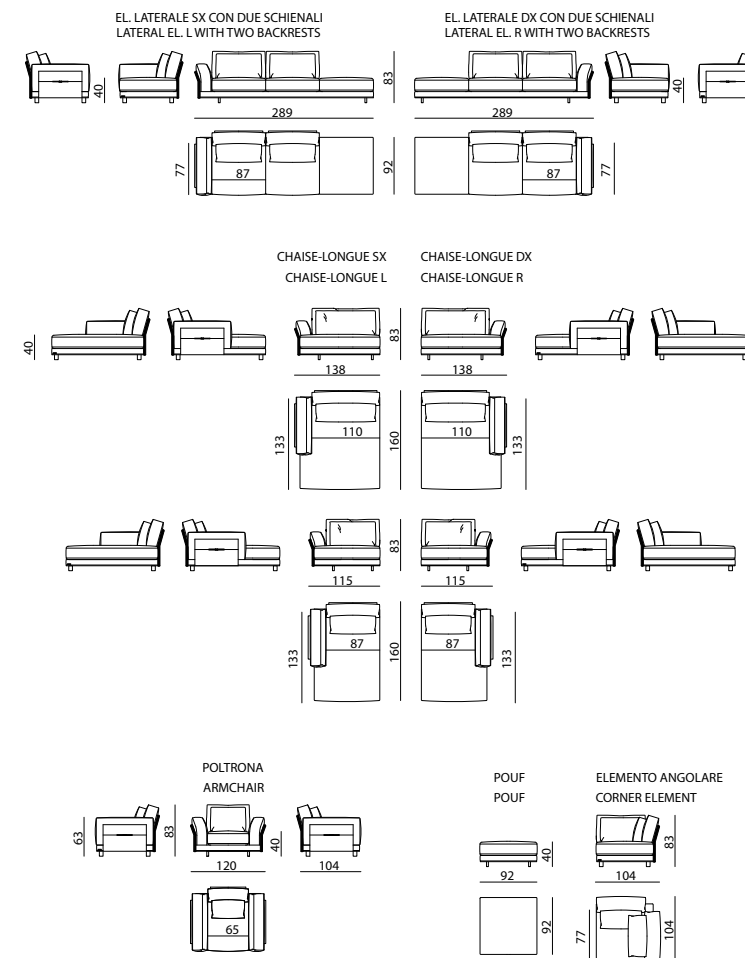
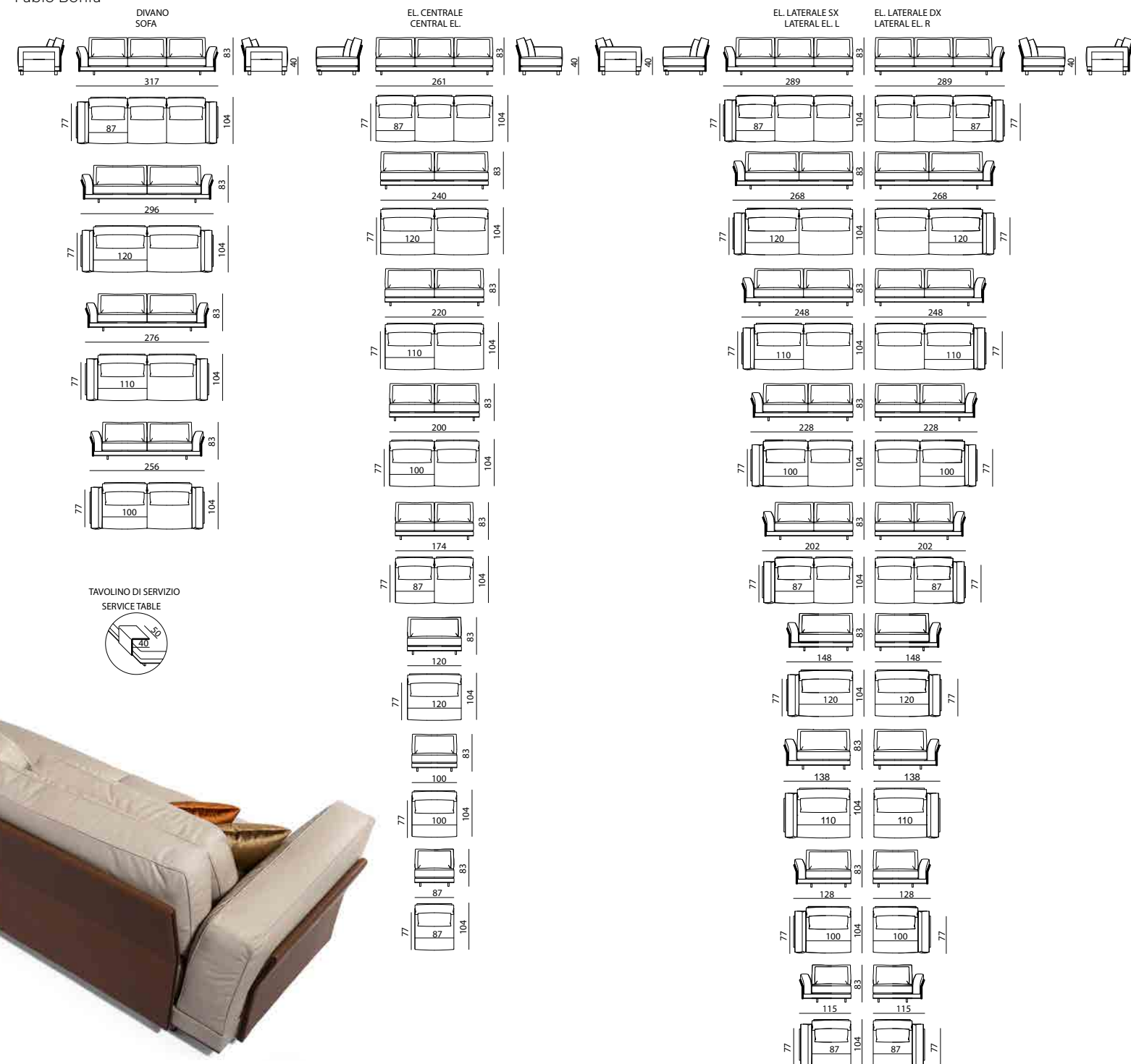

VERSIONE RADICA/ RADICA VERSION

VERSIONE RADICA/ RADICA VERSION

Struttura in legno lamellare e pannelli in mdf con cinghiere elastiche, imbottitura dei cuscini di seduta in poliuretano a diverse densità, Memory Foam® e piuma. Rivestimento in pelle o tessuto. Cuscini volanti di schienale e braccioli in piuma. Supporti di schienali e braccioli in legno sagomato rivestito in pelle o tessuto, con profili decorativi in acciaio. Piedi e profilo della base in acciaio. Le parti in metallo sono disponibili nella selezione finiture metalliche.

Disponibile versione ANTHEM RADICA con supporti di schienale e braccioli rivestiti in radica con finitura lucida 100 gloss.

Structure in laminate and MDF panels with elastic belt spring system. Seat cushions padded in polyurethane with different densities, Memory Foam® and feather. Upholstery in leather or fabric. Loose cushions for back and armrests padded in feather. Back and armrest supports in shaped wood upholstered in leather or fabric, with decorative steel profiles. Feet and base profile in steel. Metal details can be finished with any lacquer of the metal lacquer finish selection.

ANTHEM RADICA version available with backrest and armrest supports upholstered in polished burr walnut with 100 gloss finish.

[click here](#)

MONDRIAN

TAVOLINO, BRACCIOLO - LOW TABLE, ARMREST
Fabio Bonfà

Tavolo basso. Telaio in acciaio satinato a sezione quadrata con saldature invisibili e ripiano in cristallo extra chiaro o fumè. Top e fianco verticale in marmo tagliato in continuità di vena. Le parti in metallo sono disponibili nella selezione finiture metalliche.

Low table. Squared frame in satin steel with invisible welded joints, shelf in extra clear or smoked crystal glass. Top and side panel in vein-cut marble. Metal details can be finished with any lacquer of the metal lacquer finish selection.

vedi anche/see also MONDRIAN tavolo basso-low table, MONDRIAN consolle-console

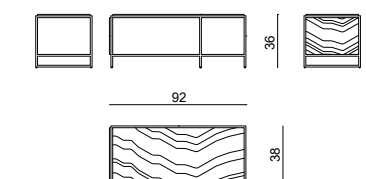



ASHTON

DIVANO - SOFA

Alessandro La Spada - Samuele Mazza

Struttura portante in pannelli multistrati di pioppo e listelli di abete. Molleggio seduta a cinghie elastiche intrecciate. Imbottitura scocca in poliuretano su pannelli in multistrati, predisposti per realizzazione tappezzeria capitonné. Cuscini seduta in poliuretano a quote differenziate e rifascio in piuma incamerata. Cuscini schienale in piuma con supporto interno in poliuretano. Fasce di schienali, braccioli e frontali in vetro bisellato o in MDF bisellato e laccato lucido. Base in MDF laccata. Rivestimento della scocca in pelle o tessuto non sfoderabile. Rivestimento cuscini seduta e schienale sfoderabili.

Main structure in poplar plywood and fir strips. Seat sprung system made of twisted elastic belts. Frame padding in polyurethane on plywood, predisposed for capitonné upholstery. Seat cushions in polyurethane in different densities and cover in feather. Back cushions in feather with polyurethane internal support. Back, arms and front bands in bevelled glass or in polished lacquered bevelled MDF. Base in lacquered MDF. Structure cover in fabric or leather, not removable. Seat and back cushions with removable covers.

● click here

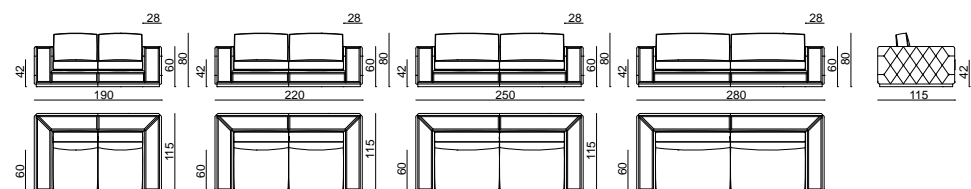

DIVANO / SOFA

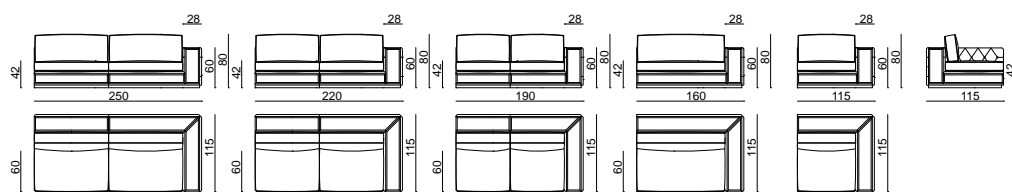

ELEMENTO LATERALE DX / RIGHT LATERAL ELEMENT

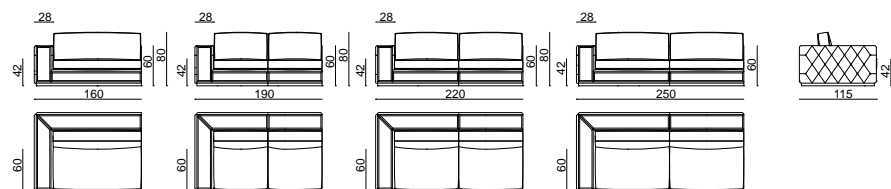

ELEMENTO LATERALE SX / LEFT LATERAL ELEMENT

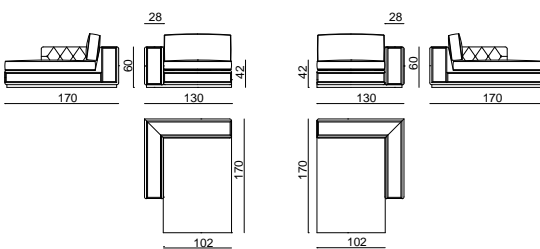

CHAISE-LONGUE SX / LEFT CHAISE-LONGUE

CHAISE-LONGUE DX / RIGHT CHAISE-LONGUE



BALANCE

DIVANO, POLTRONA, CHAISE-LONGUE, POUF
SOFA, ARMCHAIR, CHAISE-LONGUE, POUFFE

Alessandro La Spada

Struttura interna in legno massello e multistrati con molleggio elastico. Scocca sospesa e cuscini di seduta imbottiti con rivestimento fisso, in pelle o tessuto. Schienale alto e fianchi a bergère. Imbottitura in poliuretano a diverse densità, memory foam® e piuma. Cuscini schienale e cuscini volanti in piuma con retro microforato. Base rivestita in acciaio inox satinato. Disponibile pouf quadrato con struttura interna in legno e multistrati, imbottitura in poliuretano a diverse densità. Rivestimento in pelle o tessuto. Le parti metalliche sono disponibili nella selezione finiture metalliche satiniate.

Internal structure in solid wood and plywood with elastic suspension. Suspended shell and upholstered seat cushions with fixed cover, upholster in leather or fabric. High back and bergère sides. Padding in different density polyurethane, memory foam® and feather. Back cushions and down cushions in feather. Base covered in satin stainless steel. Also available pouffe with internal structure in solid wood and plywood, padded in polyurethane with different densities. Upholstery in leather or fabric. Metal parts available in the satinized metal finishing selection.

vedi anche/see also BALANCE letto-bed

● click here

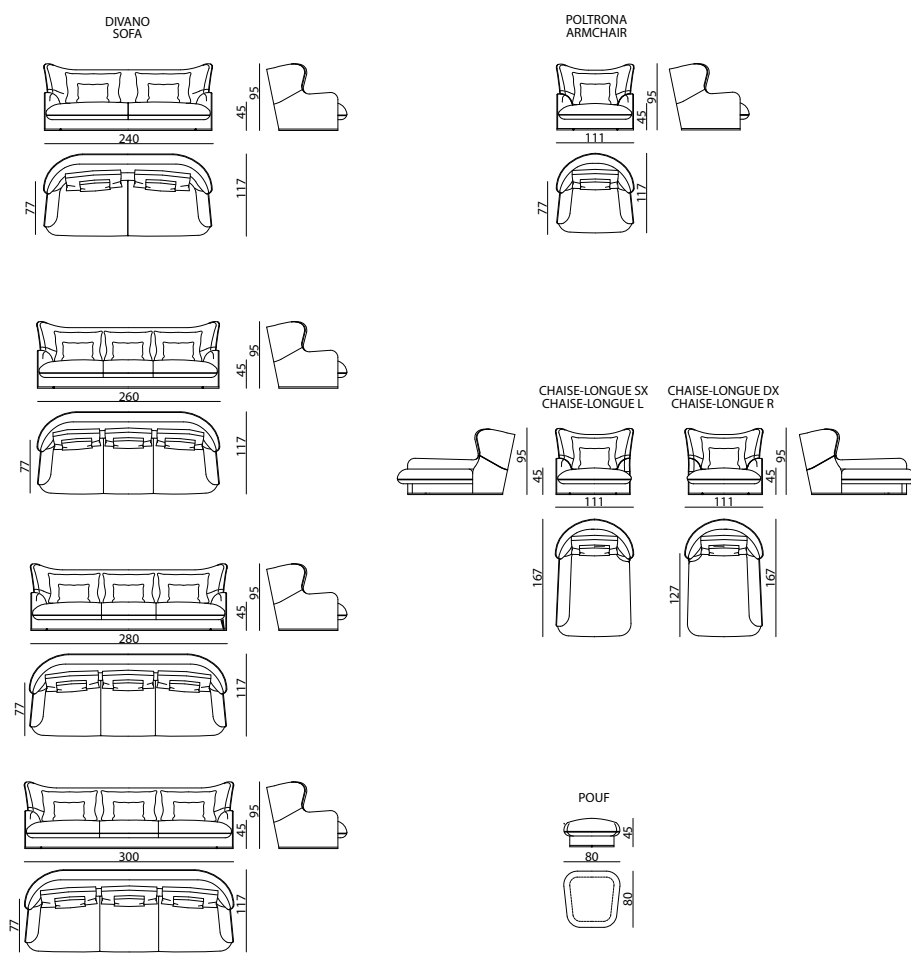



BABYLON

DIVANO, ELEMENTI COMPONENTI, POLTRONA, CHAISE-LONGUE, TAVOLINO
 SOFA, MODULAR ELEMENTS, ARMCHAIR, CHAISE-LONGUE, LOW TABLE

Alessandro La Spada

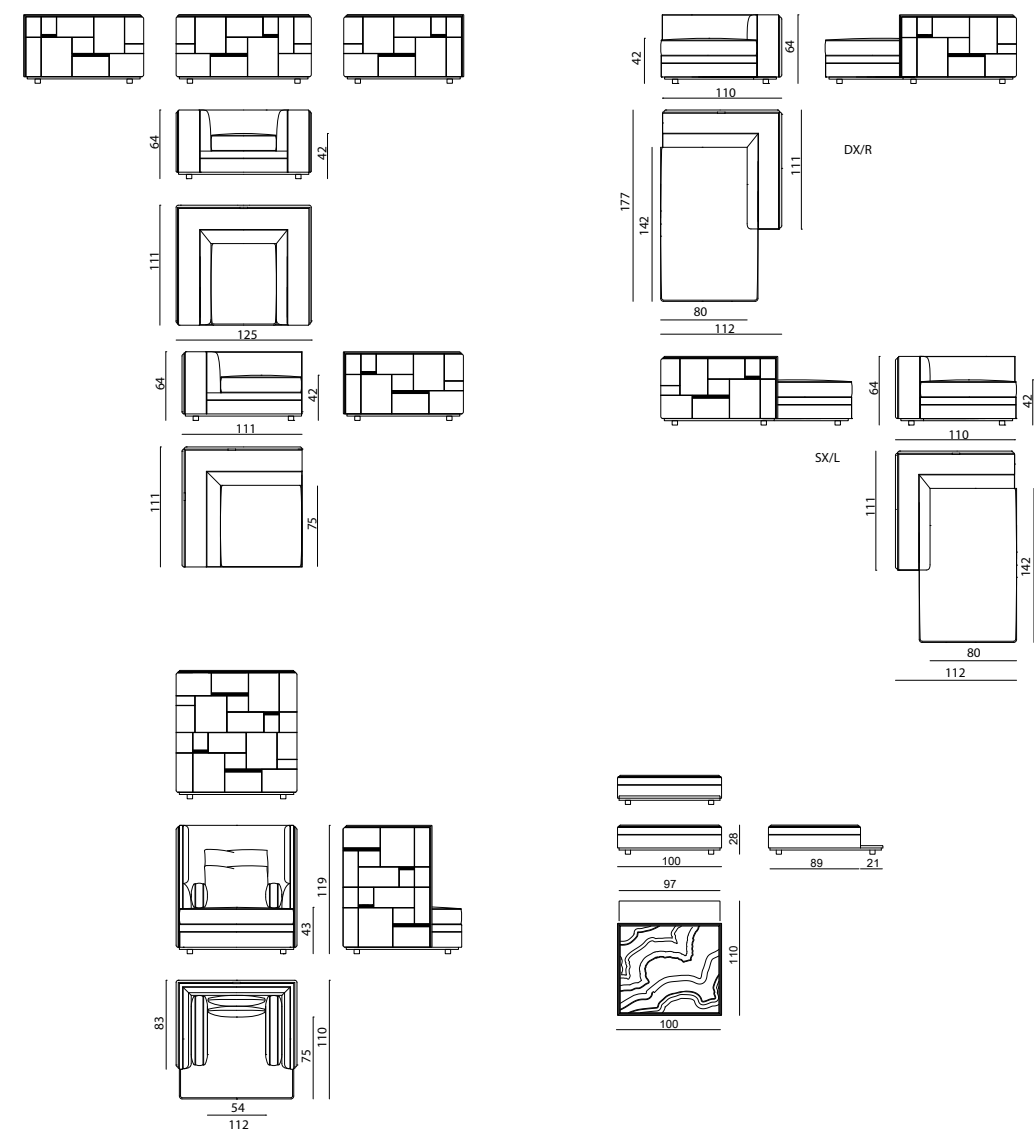
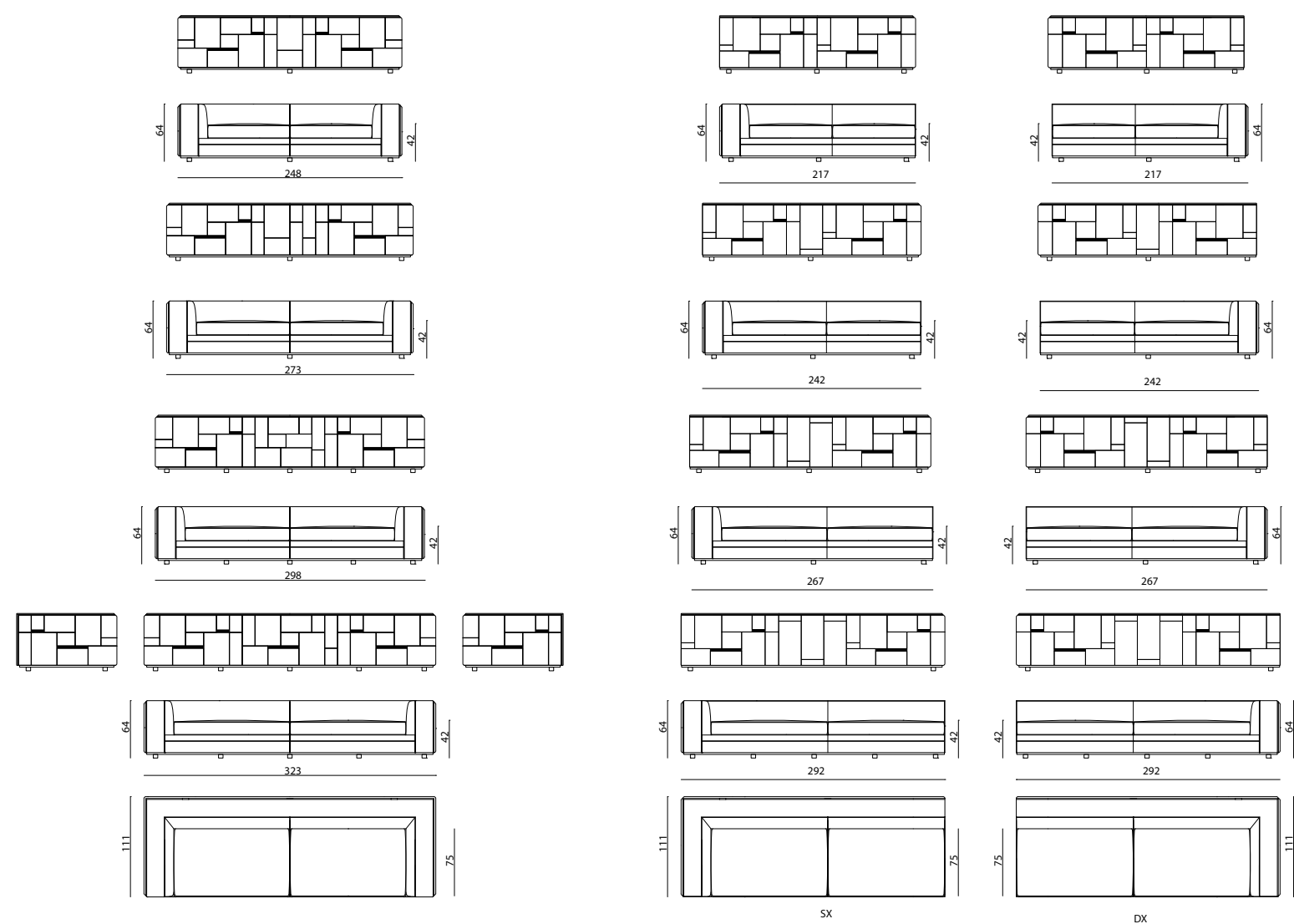

Struttura interna in legno massello e multistrati con molleggio a cinghie elastiche, imbottitura in poliuretano espanso. Schienale e braccioli tappezzati esternamente con pannelli leggermente imbottiti a formare un motivo geometrico astratto e inserti in acciaio satinato con logo, piano superiore dei braccioli liscio, profilo perimetrale in acciaio inox satinato con clips marchiate Visionnaire. Rivestimento in pelle o tessuto. Cuscini di seduta in poliuretano, strato superiore in Memory Foam® e piuma d'oca. Cuscini volanti in piuma d'oca. Le parti metalliche sono disponibili nella selezione finiture metalliche satinato. Disponibile elemento tavolo basso con vano portariviste tappezzato e top in marmo.

Internal structure in solid wood and plywood with elastic strap springing system; padding in polyurethane foam. Backrest and armrests externally upholstered with slightly padded tiles, creating an abstract geometrical motive and inserts in satinized steel with logo; smooth upper surface of the armrests; perimetral profile in satinized stainless steel with clips with engraved Visionnaire logo. Upholstery in leather or fabric. Seat cushions in polyurethane, upper layer in Memory Foam® and goose feathers. Loose cushions in goose feathers. Metal parts available in the satinized metal finishing selection. Optional element available: low table with upholstered magazine-holder shelf and top in marble.

click here



BABYLON RACK

DIVANO, ELEMENTI componibili, POLTRONA, CHAISE-LONGUE
 SOFA, MODULAR ELEMENTS, ARMCHAIR, CHAISE-LONGUE
 Alessandro La Spada

SOFA

CONCAVE ARMREST/BACKREST

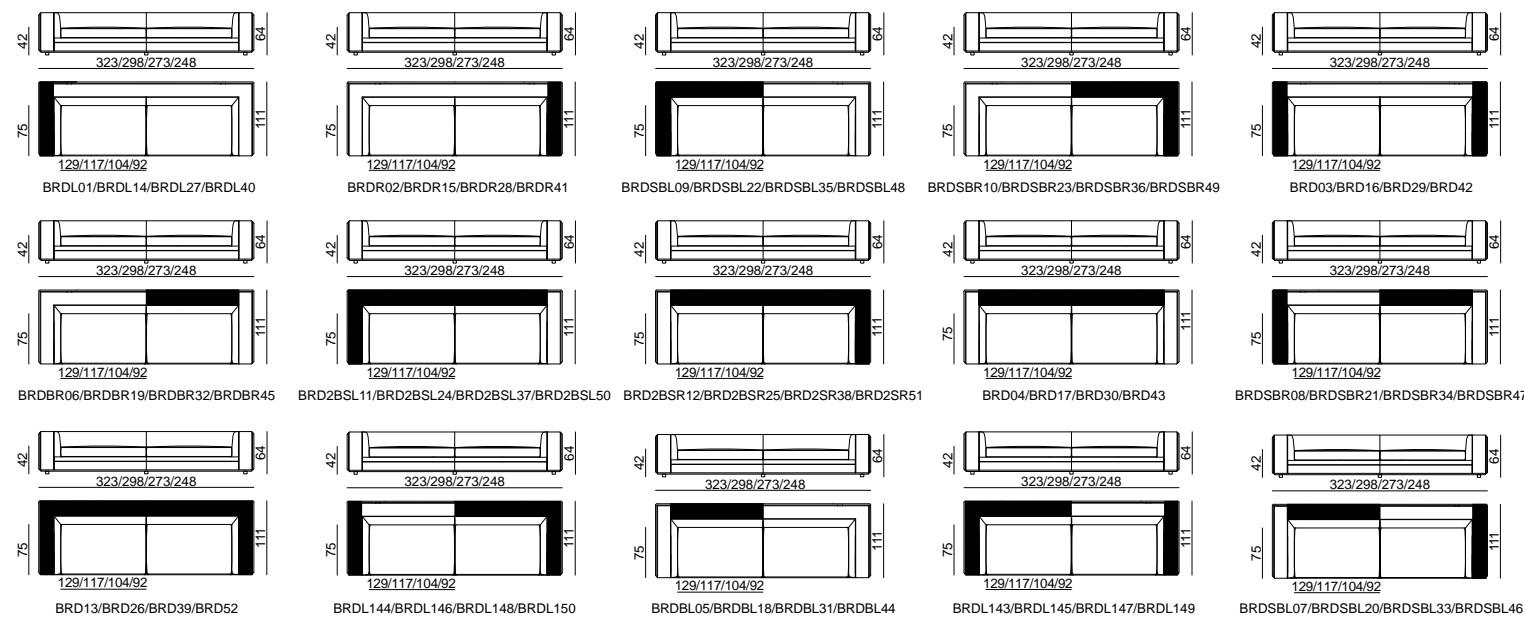

LEFT LATERAL ELEMENT

CONCAVE ARMREST/BACKREST



RIGHT LATERAL ELEMENT

CONCAVE ARMREST/BACKREST

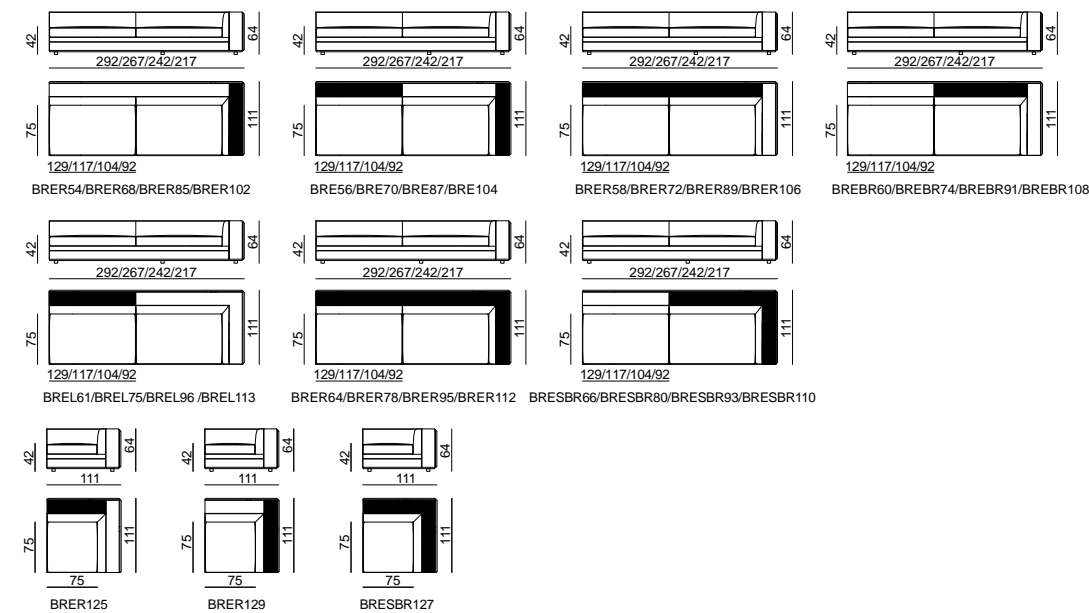

Divano e divano componibile, struttura interna in legno massello e multistrati con molleggio a cinghie elastiche, imbottitura in poliuretano espanso. Schienale e braccioli tappezzati esternamente con pannelli leggermente imbottiti a formare un motivo geometrico astratto e inserti in acciaio satinato con logo. Schienali e braccioli possono essere concavi a formare dei vani libreria, con illuminazione diffusa a LED. Il piano superiore dello schienale può ospitare, in opzione, dei poggiatesta magnetici e un sistema di ricarica wireless (standard Qi) per ricarica di tablet, smartphone e lampade ricaricabili senza filo della serie Barnaby. Le finiture metalliche sono in acciaio inox satinato con clips marchiate Visionnaire. Rivestimento in pelle o tessuto. Cuscini di seduta in poliuretano, strato superiore in Memory Foam® e piuma d'oca. Cuscini volanti in piuma d'oca. Le parti metalliche sono disponibili nella selezione finiture metalliche satinato.

Linear and modular sofa with structure in solid wood and plywood with elastic belts, padded in polyurethane foam. Backrests and armrests are externally covered with slightly padded panels, designing an abstract geometrical pattern, juxtaposed with inserts in satin steel decorated with logo. Backrests and armrests can have a concave structure, consisting of open compartments for book storage, equipped with diffuse LED lights. The upper part of the backrest can be optionally provided with magnetic headrests and a wireless (standard Qi) integrated battery charger for tablet, smartphone and lamps of Barnaby series. Metal elements are available with satin finish only and they are decorated with clips with Visionnaire engraved logo. Upholstery in leather or fabric. Seat cushions padded in layer of polyurethane foam, Memory Foam® and goose feather. Loose cushions in goose feather. Metal elements available in any lacquer of the satin metal finish selection.

click here



CORNER ELEMENT

CONCAVE ARMREST/BACKREST

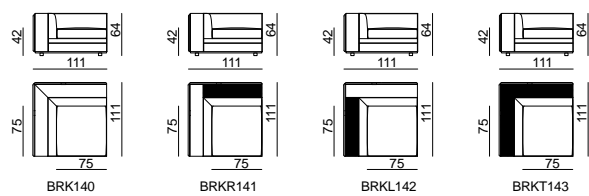

CENTRAL ELEMENT

CONCAVE ARMREST/BACKREST

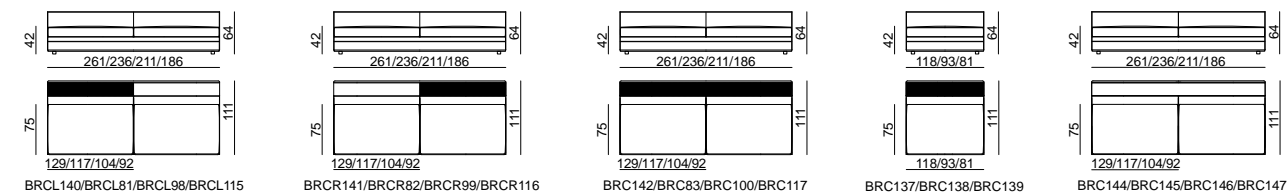

LEFT CHAISE-LONGUE

CONCAVE ARMREST/BACKREST

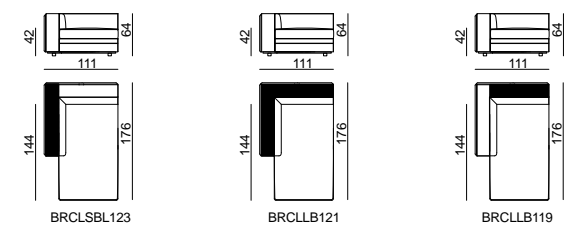

RIGHT CHAISE-LONGUE

CONCAVE ARMREST/BACKREST

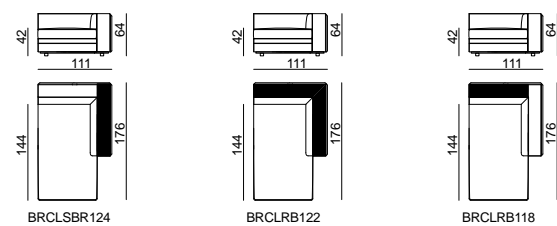

ARMCHAIR

CONCAVE ARMREST/BACKREST

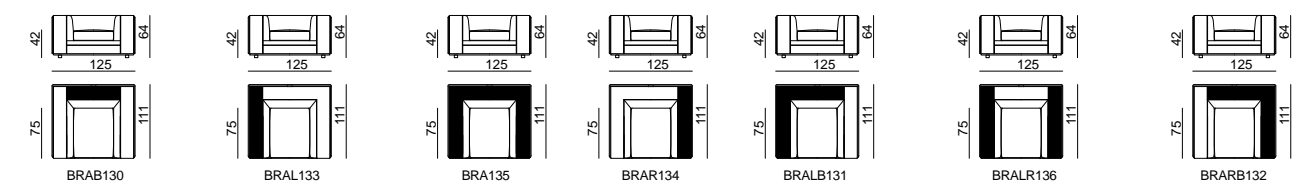

ADDITIONAL ELEMENTS

HEADREST

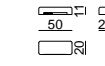

LOW TABLE

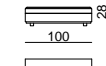

SHELF



WIRELESS CHARGING



MODULAR SOFA - EXAMPLE

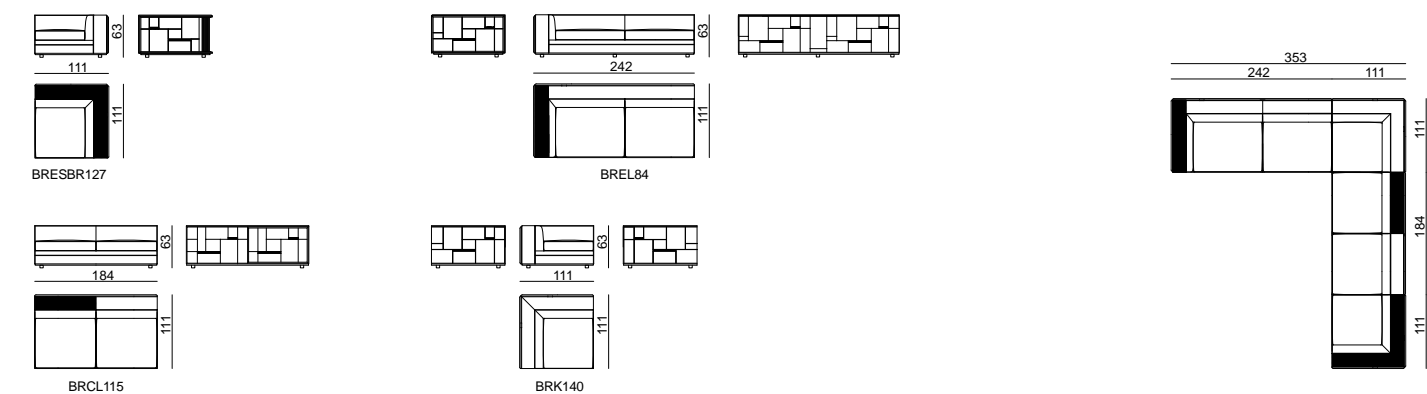



BACKSTAGE

DIVANO, ELEMENTI COMPONIBILI, POLTRONA
SOFA, MODULAR ELEMENTS, ARMCHAIR

Fabio Bonfà

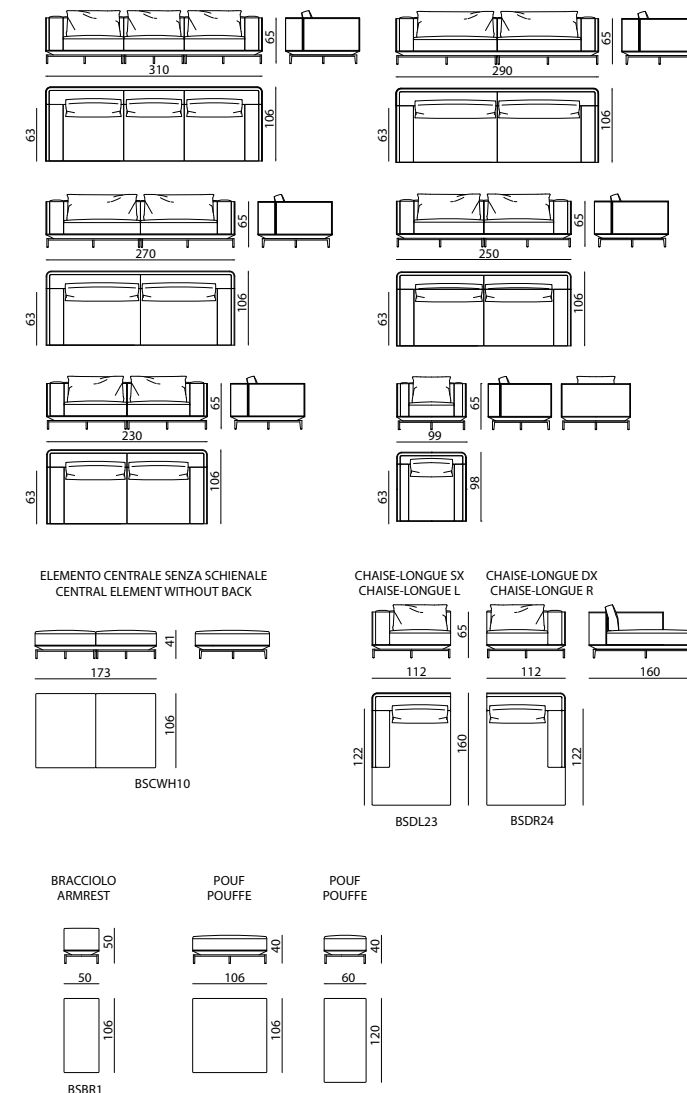
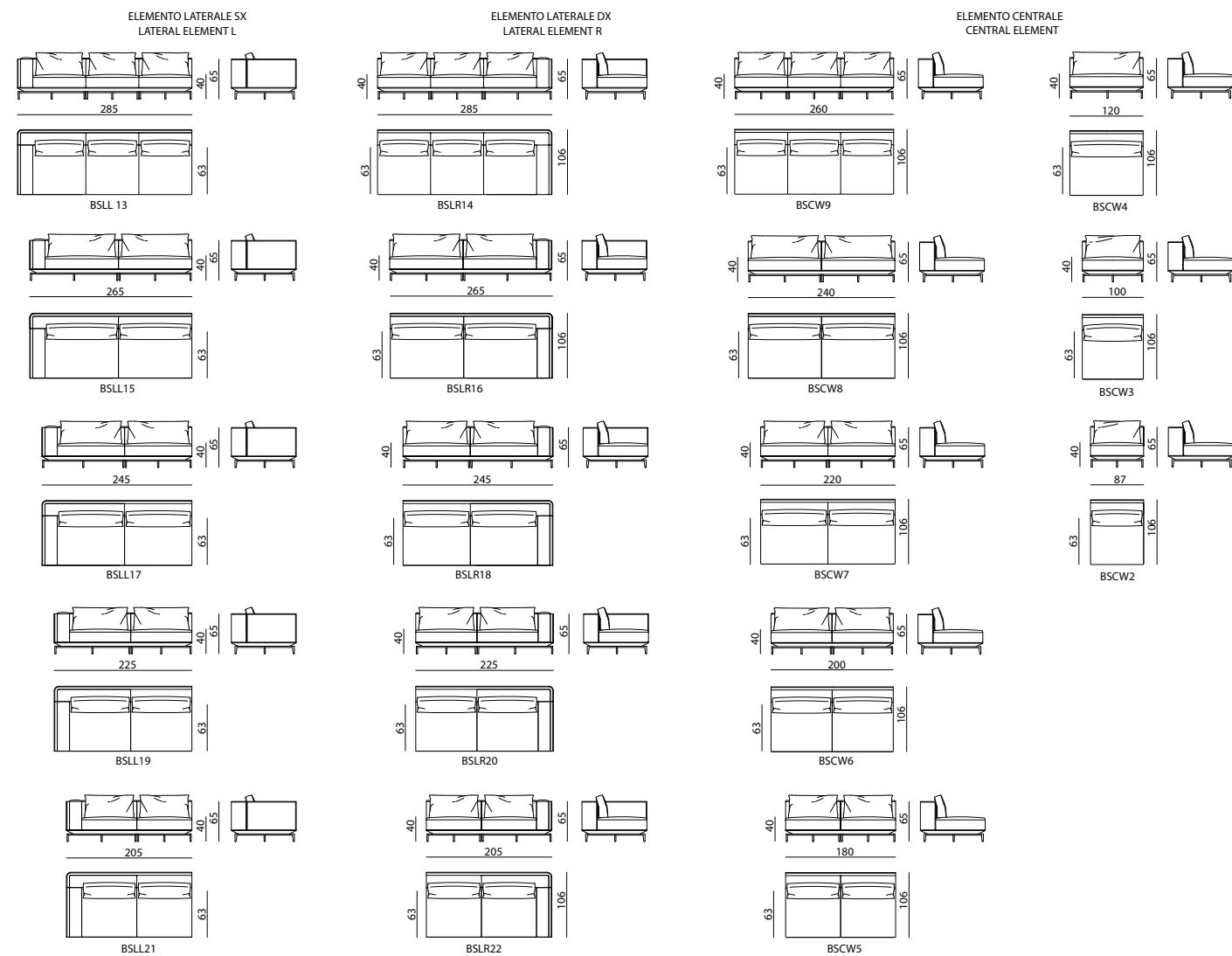

VERSIONE RADICA/ RADICA VERSION

Divano tappezzato in pelle o tessuto, con base composta da un telaio in acciaio inox satinato e un pannello in legno e metallo rivestito in pelle o tessuto, dotato di cinghie elastiche per il molleggio dei sedili. Braccioli e schienali in legno bordati da un profilo in acciaio sp. 10x10 mm tappezzati con pelle, tessuto oppure pelle intrecciata imbottiti nella parte interna. Cuscini di seduta in poliuretano a diverse densità, memory foam® e piuma. Cuscini di schienale e interno bracciolo in poliuretano e piuma, cuscini volanti in piuma. Le parti metalliche sono disponibili nella selezione finiture metalliche satinato. Versione componibile disponibile con elementi centrali senza schienale abbinabili alla consolle Banner.

Disponibile versione BACKSTAGE RADICA con scocca esterna in radica con finitura lucida 100 gloss.

Sofa upholstered in leather or fabric, with base composed of a frame in satinized stainless steel and a panel in wood and metal covered in leather or fabric, equipped with elastic belts for the seats suspension. Armrests and backrests made of a wooden panel edged by a steel profile th.10x10 mm, and upholstered with leather, fabric or woven leather padded on the inside. Seat cushions in polyurethane with different densities, memory foam® and feather. Back and armrest cushions in polyurethane and feather, loose cushions in feather. Metal parts available in the satinized metal finishing selection. Modular sofa available with central elements without backrest that can be combined with the Banner console.

Available BACKSTAGE RADICA version with external shell in burr walnut with 100 gloss finish.

vedi anche/see also BACKSTAGE poltroncina-armchair

[click here](#)



BASTIAN DUAL

DIVANO, ELEMENTI COMPONENTI, POLTRONA, CHAISE-LONGUE
SOFA, MODULAR ELEMENTS, ARMCHAIR, CHAISE-LONGUE

Mauro Lipparini

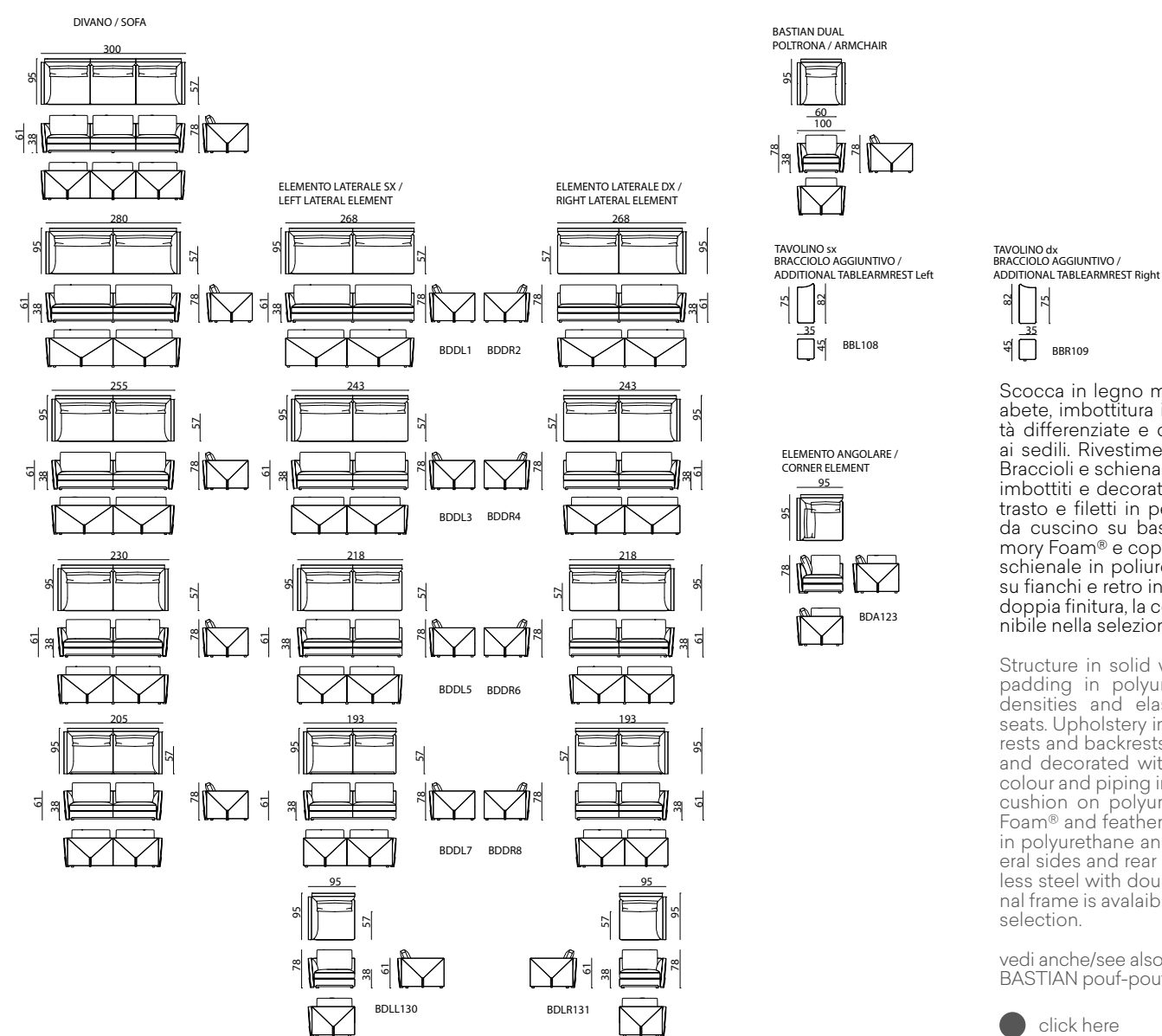
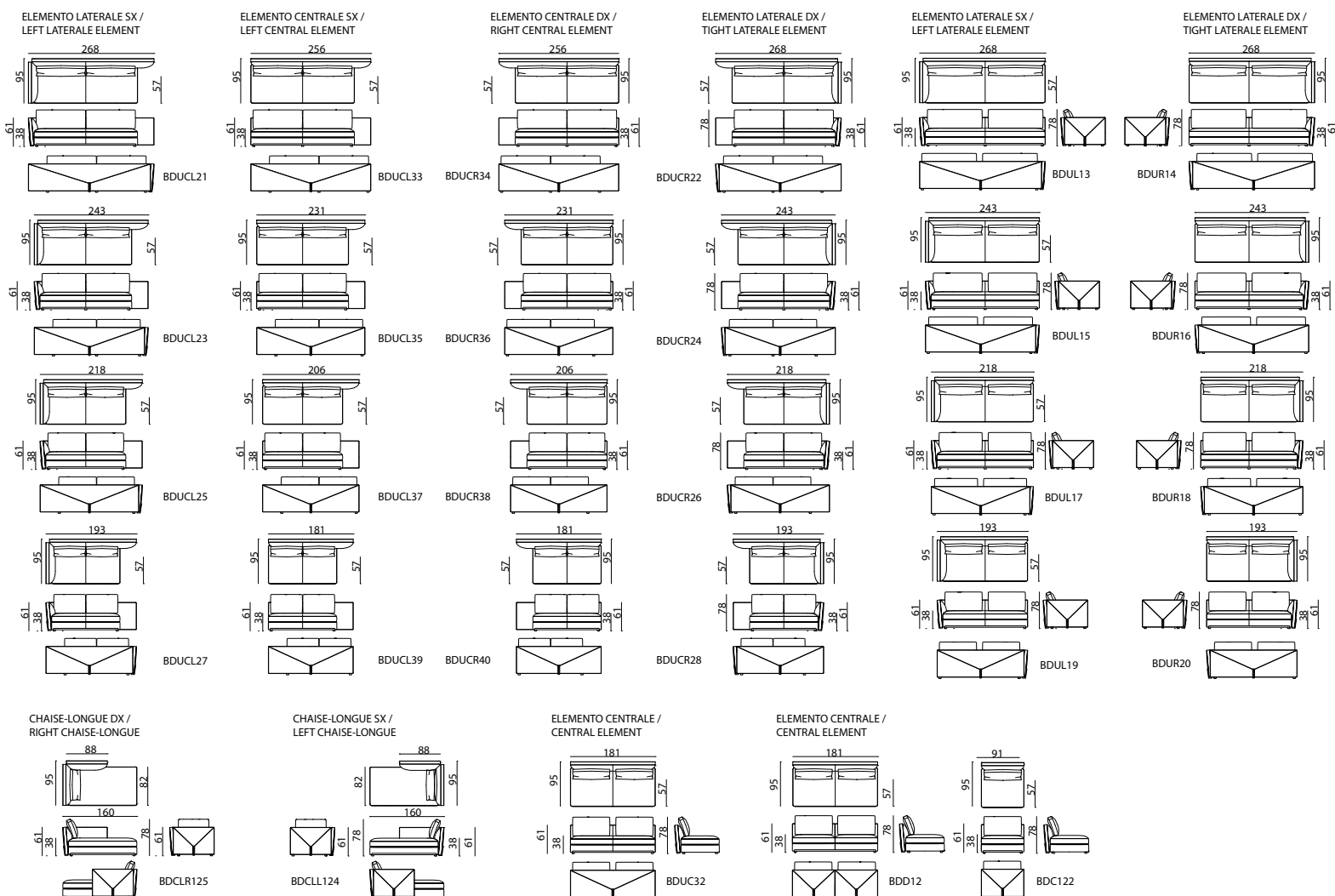

Scocca in legno massello e multistrati di abete, imbottitura in poliuretano a densità differenziate e cinghie elastiche sotto ai sedili. Rivestimento in pelle o tessuto. Braccioli e schienali realizzati con pannelli imbottiti e decorati con fettuccia in contrasto e filetti in pelle. Seduta composta da cuscino su base in poliuretano, Memory Foam® e copertina in piuma; cuscini schienale in poliuretano e piumino. Fregi su fianchi e retro in acciaio inox satinato a doppia finitura, la cornice esterna è disponibile nella selezione finiture metalliche.

Structure in solid wood and fir plywood, padding in polyurethane with different densities and elastic straps under the seats. Upholstery in leather or fabric. Armrests and backrests made of padded tiles and decorated with insert in contrasting colour and piping in leather. Seat made of: cushion on polyurethane base, Memory Foam® and feathers cover; back cushions in polyurethane and down. Friezes on lateral sides and rear back in satinized stainless steel with double finishing, the external frame is available in the metal finishing selection.

vedi anche/see also BASTIAN letto-bed, BASTIAN pouf-pouffe

● click here



BASTIAN STILL

DIVANO, ELEMENTI COMPONENTI, POLTRONA, CHAISE-LONGUE, POUF

SOFA, MODULAR ELEMENTS, ARMCHAIR, CHAISE-LONGUE, POUFFE

Mauro Lipparini

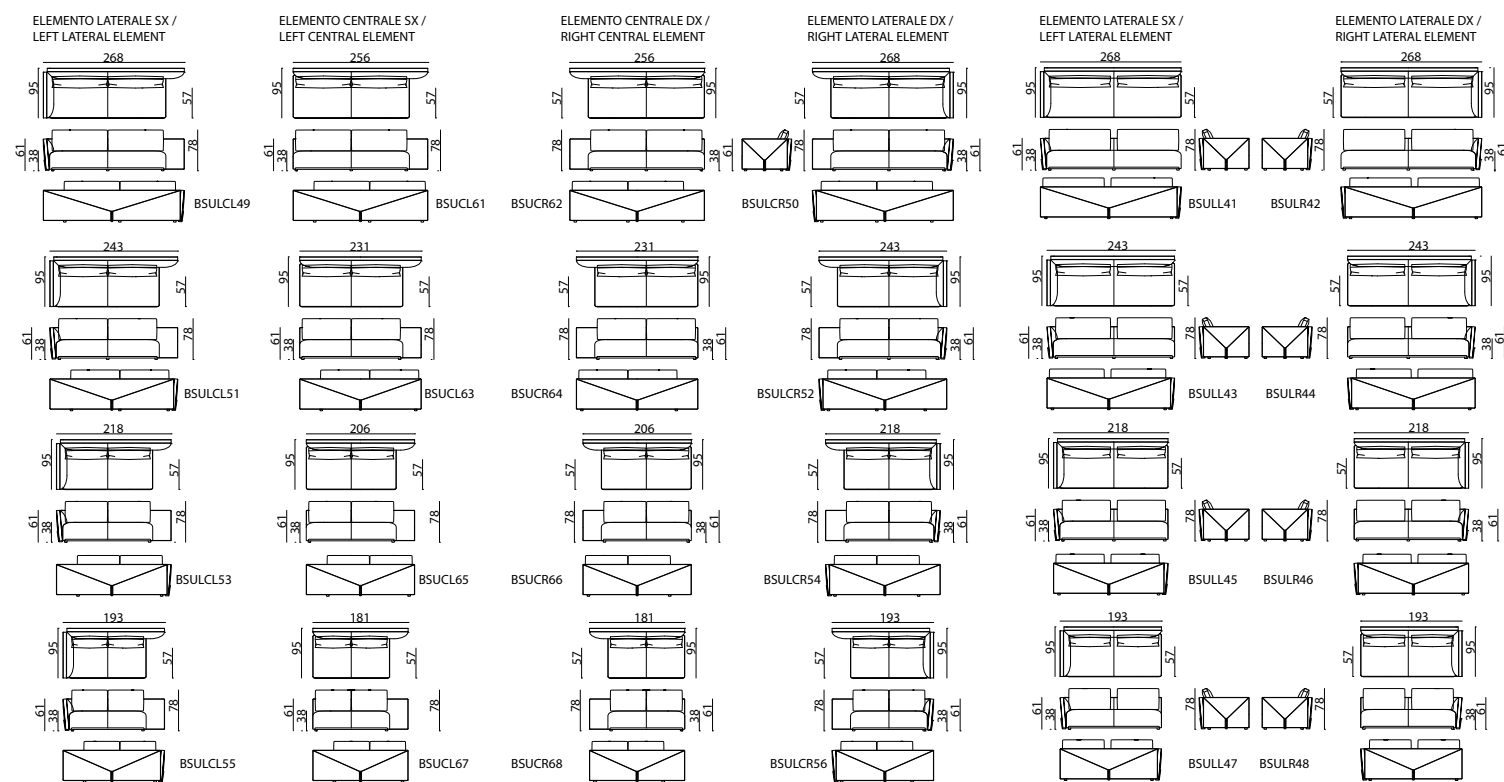

CHAISE-LONGUE DX / RIGHT CHAISE-LONGUE

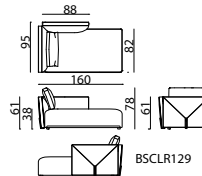

CHAISE-LONGUE SX / LEFT CHAISE-LONGUE

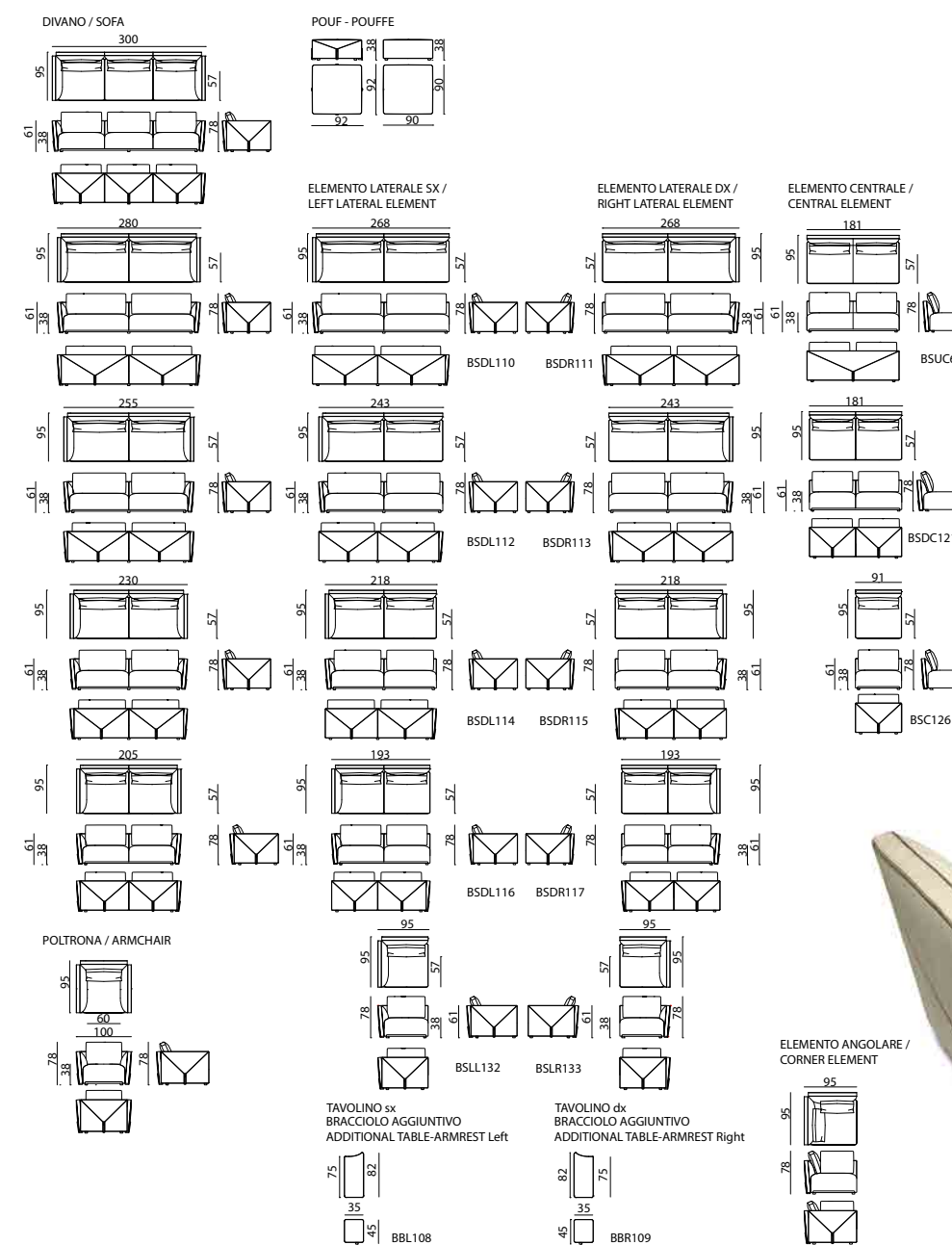
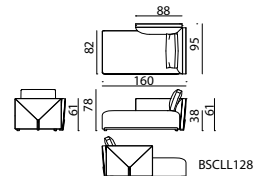

Scocca in legno massello e multistrati di abete, imbottitura in poliuretano a densità differenziate e cinghie elastiche sotto ai sedili. Rivestimento in pelle o tessuto. Braccioli e schienali realizzati con pannelli imbottiti e decorati con fettuccia in contrasto e filetti in pelle. Seduta composta da cuscino monoscocca in poliuretano, Memory Foam® e copertina in piuma e cuscini schienale in poliuretano e piumino. Fregi su fianchi esterni e retro schienali in acciaio inox satinato a doppia finitura. Pouf quadrato con struttura interna in legno massello e multistrati di abete, imbottitura in poliuretano a densità differenziate. Rivestimento in pelle o tessuto. Fettucce decorative ribattute in pelle o tessuto. Filetti in pelle. Disponibile anche con fregi sui fianchi in alluminio satinato e interno in acciaio inox satinato naturale, la cornice esterna è disponibile nella selezione finiture metalliche.

Structure in solid wood and fir plywood, padding in polyurethane with different densities and elastic straps under seats. Upholstery in leather or fabric. Armrests and backrests made of padded tiles and decorated with insert in contrasting colour and pipings in leather. Seat cushion in one piece integrated with the structure, made of polyurethane, Memory Foam® and lining in feathers; back cushions in polyurethane and down. Friezes on external sides and rearback in satinized stainless steel with double finishing. Squared pouffe with internal structure in solid wood and fir plywood, padding in polyurethane with different densities. Upholstery in leather or fabric. Decorative inserts with felled seams, made in leather or fabric. Pipings in leather. Option also available: friezes on lateral sides in satinized aluminium and internal plate in satinized stainless steel, the external frame is available in the metal finishing selection.

● click here





BASTIAN LOUNGE

DIVANO, ELEMENTI COMPONIBILI, TAVOLO BASSO

SOFA, MODULAR ELEMENTS, LOW TABLE

Mauro Lipparini

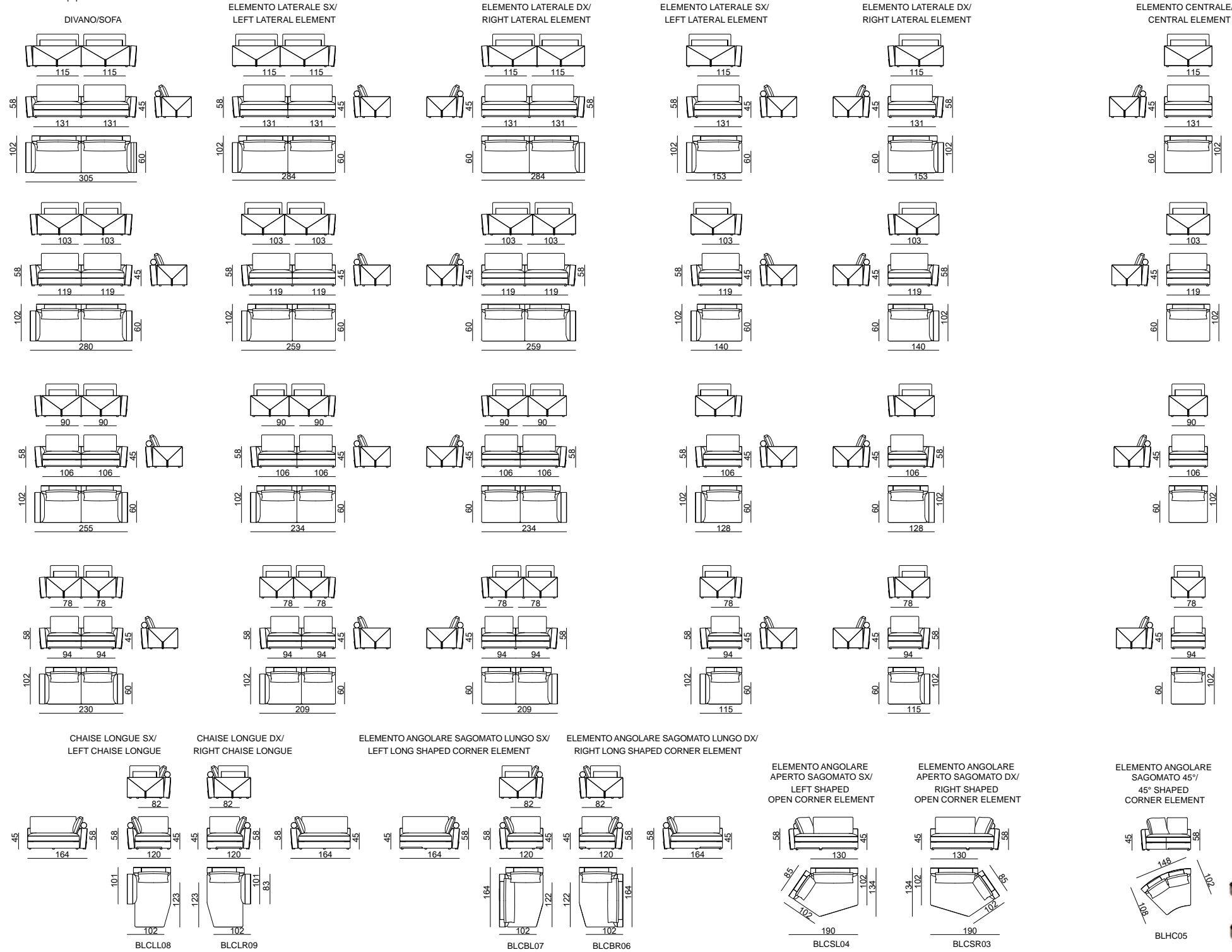

ESEMPI DI COMPOSIZIONI/
MODULAR SOFA SAMPLES

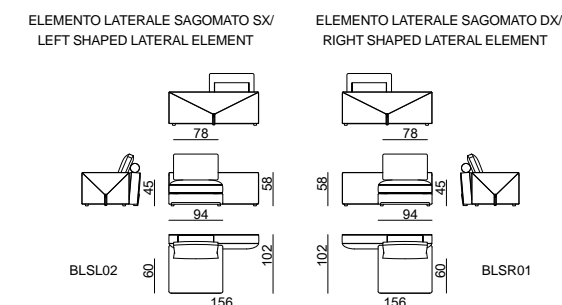
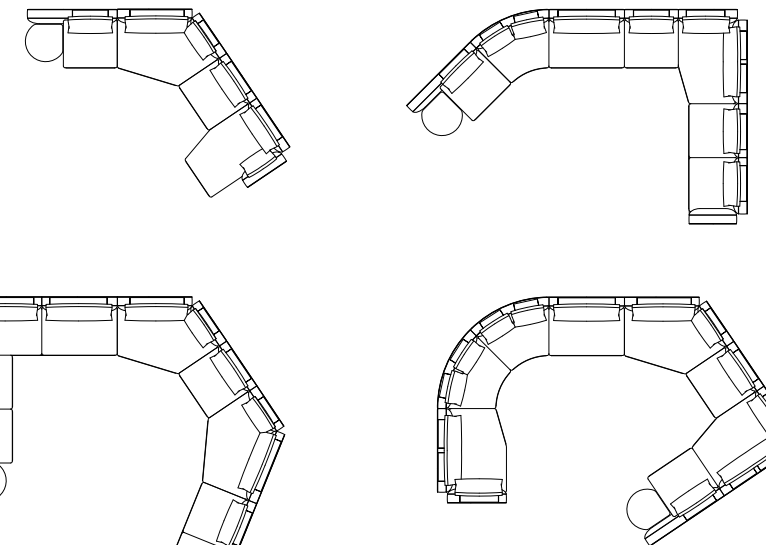

Scocca in legno massello e multistrati di abete, imbottitura in poliuretano a densità differenziate e molleggio a cinghie elastiche. Rivestimento in pelle o tessuto. Braccioli e schienali scatolati in legno e imbottiti e decorati con fettuccia in contrasto e filetti in pelle. Seduta composta da cuscino su base in poliuretano, Memory Foam® e copertina in piuma; cuscini di schienale in poliuretano e piumino. Fregi su fianchi e retro in acciaio inox satinato a doppia finitura, la cornice esterna è disponibile nella selezione finiture metalliche. Tavolino basso in legno impiallacciato (disponibile nelle finiture selezione essenze opache e lucide) oppure laccato (colori RAL/NCS).

Structure in solid and multiply fir wood, padding in polyurethane with variable density and elastic strip springing. Upholstered in leather or fabric. Padded arms and backrests in wood, decorated with inserts in contrasting colour and pipings in leather. Seat made of cushion on polyurethane base, Memory Foam® and feathers cover; back cushions in polyurethane and down. Friezes on lateral sides and rear back in satinized stainless steel with double finishing, the external frame is available in the metal finishing selection. Low table in veneered wood (available in the veneer selection with mat and polished finish) or lacquered (RAL/NCS colours).

vedi anche/see also BASTIAN letto-bed, BASTIAN pouf-pouffe

[click here](#)



CA' FOSCARI

DIVANO, POLTRONA, POUF
SOFA, ARMCHAIR, POUFFE

Alessandro La Spada

Divano, poltrona con tappezzeria fissa in pelle o tessuto, fusto in legno multistrati e massello con cinghie elastiche. I sedili, e le parti interne di braccioli e schienali sono imbottiti singolarmente in poliuretano a diverse densità, Memory Foam® e piuma. Cuscini volanti in piuma. Base sagomata in legno rivestita in acciaio inox lucido curvato a profilo concavo. Profili decorativi in acciaio lucido sui fianchi dei braccioli. Le parti decorative in metallo sono disponibili nella selezione finiture metalliche.

Sofa, armchair with non-removable upholstery in leather or fabric, structure in plywood and solid wood with elastic webbing belts. Seats, internal parts of armrests and backrests padded one by one with differentiated-density polyurethane foam, Memory Foam® and feather. Loose cushions in feather. Shaped base in wood covered in curved stainless steel with concave profile and shiny finish. Decorative profiles on armrests in shiny steel. Decorative metal elements can be finished with any lacquer of the metal lacquer finish selection.

vedi anche/see also CA' FOSCARI letto-bed,
CA' FOSCARI comodino-bedside table

● click here

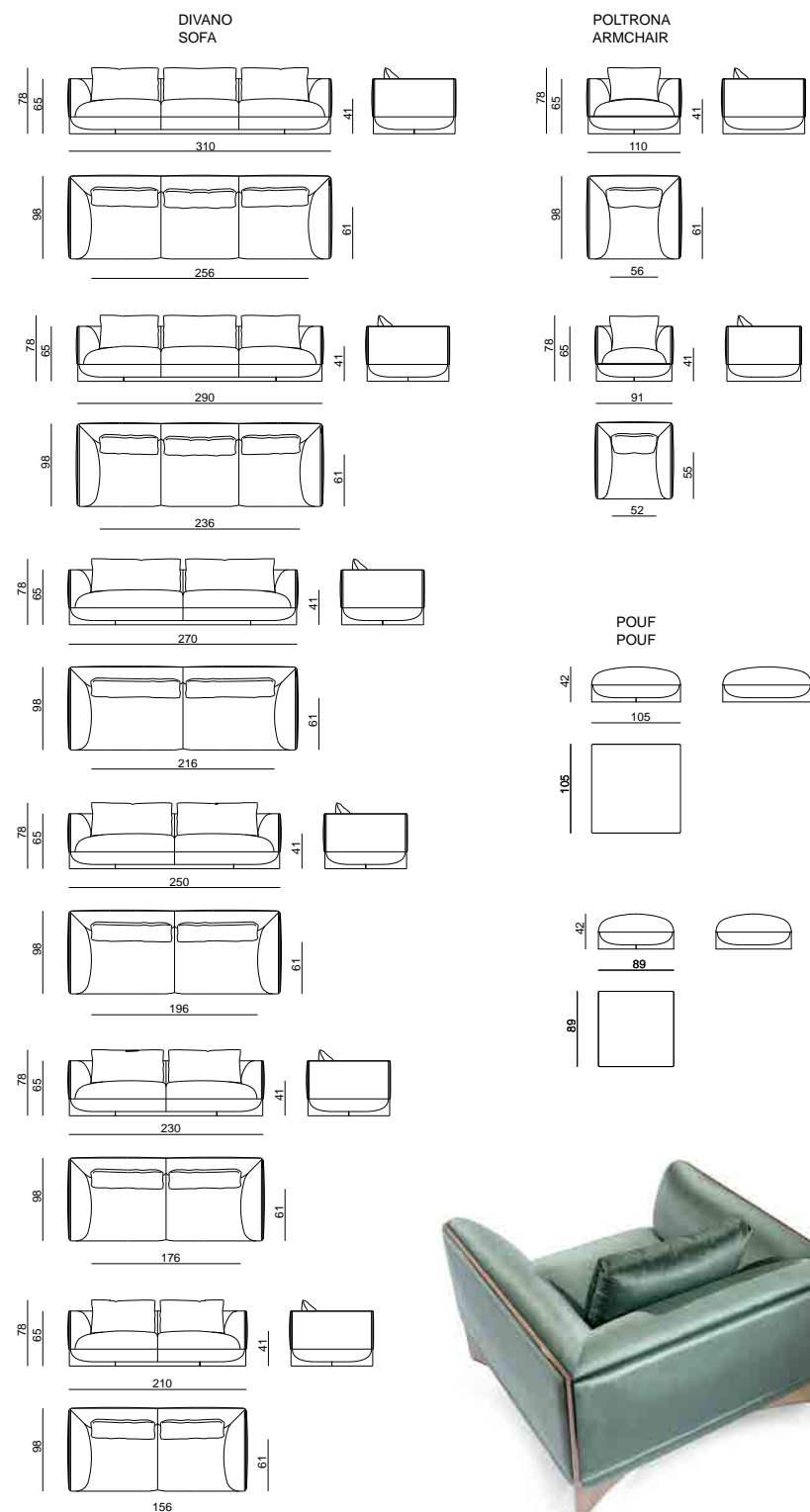

CAPITOL

DIVANO, ELEMENTI COMPONENTI,
CHAISE-LONGUE, POLTRONA - SOFA, MODULAR
ELEMENTS, CHAISE-LONGUE, ARMCHAIR

Alessandro La Spada

Struttura mista in legno e metallo con molleggio a cinghie elastiche. Imbottitura in poliuretano a densità differenziate. Cuscino di seduta in poliuretano, Memory Foam® e falda acrilica. Schienale avvolgente con lavorazione a grandi plissé imbottiti, cuscini volanti in piuma. Rivestimento in pelle o tessuto. Piedi in acciaio inox di forma semicilindrica con parte piana lavorata con satinatura profonda e logo Visionnaire inciso. Le parti in metallo sono disponibili nella selezione finiture metalliche.

Wooden and metal structure with spring system with straps; padding in polyurethane foam in different densities. Seat cushion in polyurethane, Memory Foam® and acrylic fibre. Embracing backrest with large-pleats pattern, padded in acrylic fibre; loose cushions in feather. Upholstery in leather or fabric. Feet in stainless steel, semi-cylindrical in shape, flat part with satinized finishings and Visionnaire logo engraved. Metal parts can be finished with any lacquer of the metal lacquer finish selection.

● click here

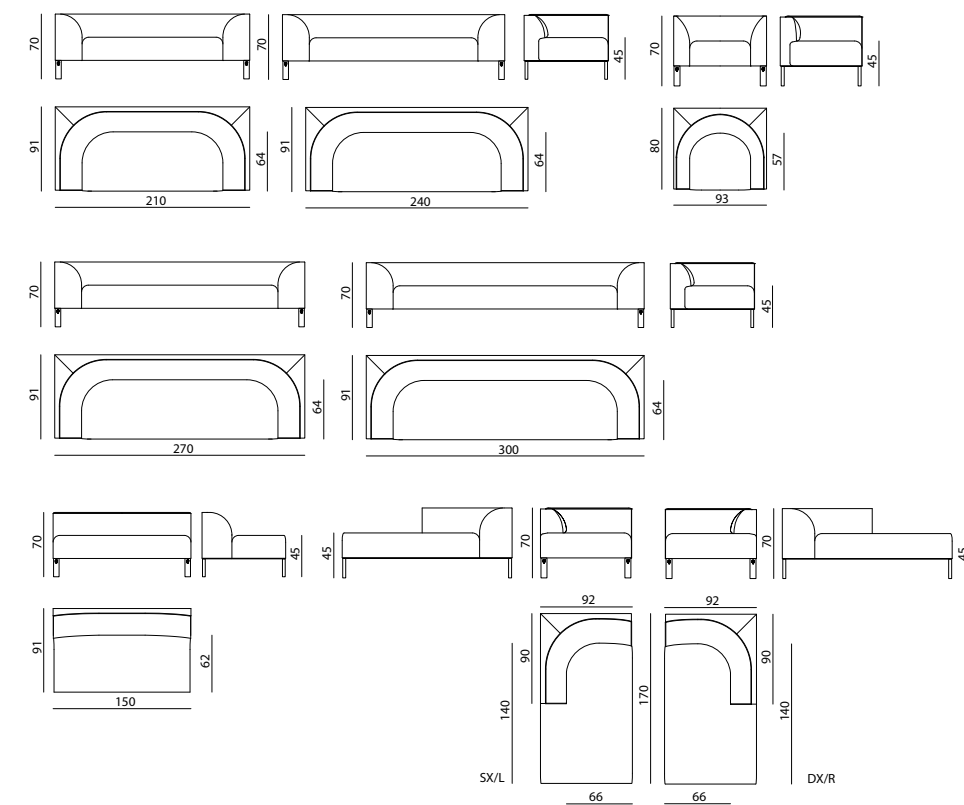



CHATAM

DIVANO, ELEMENTI COMPONENTI
SOFA, MODULAR ELEMENTS

Alessandro La Spada

Scocca portante in multistrati e masselli di legno, schienale sagomato e cuscino seduta con tappezzeria fissa, molleggio a cinghie elastiche, imbottitura in poliuretano espanso a quote differenziate. Sedile con Memory Foam® e rombo-therm, rivestimento esterno e interno in pelle o tessuto, piedi in fusione di alluminio con texture "crocco" in bassorilievo, decorazione sul basamento e bordo dei braccioli con cerniera zip in ottone e cursori in pelle con logo. Il divano è accessoriatato con cuscini 45x45 cm e cuscini 55x55 cm, il numero varia in base alle dimensioni. Cerniere e cursori oro oppure cromo. I piedi sono disponibili nella selezione finiture metalliche.

Main structure in plywood and solid wood, shaped backrest and seat cushion with fixed upholstery, sprung system with elastic bands, padding in polyurethane foam with different densities. Memory Foam® and rombo-therm seat, covered in and outside in fabric or leather. Feet in cast aluminium "crocco" engraving texture in bas-relief, base and armrest edge decoration with zips in brass and leather sliders with logo. The sofa is equipped with 45x45 cm and 55x55 cm cushions, the quantity changes according to the dimensions. Feet can be finished with any lacquer of the metal lacquer finish selection.

vedi anche/see also CHATAM tavolo da pranzo-dining table, CHARLES tavolo basso-low table

● click here

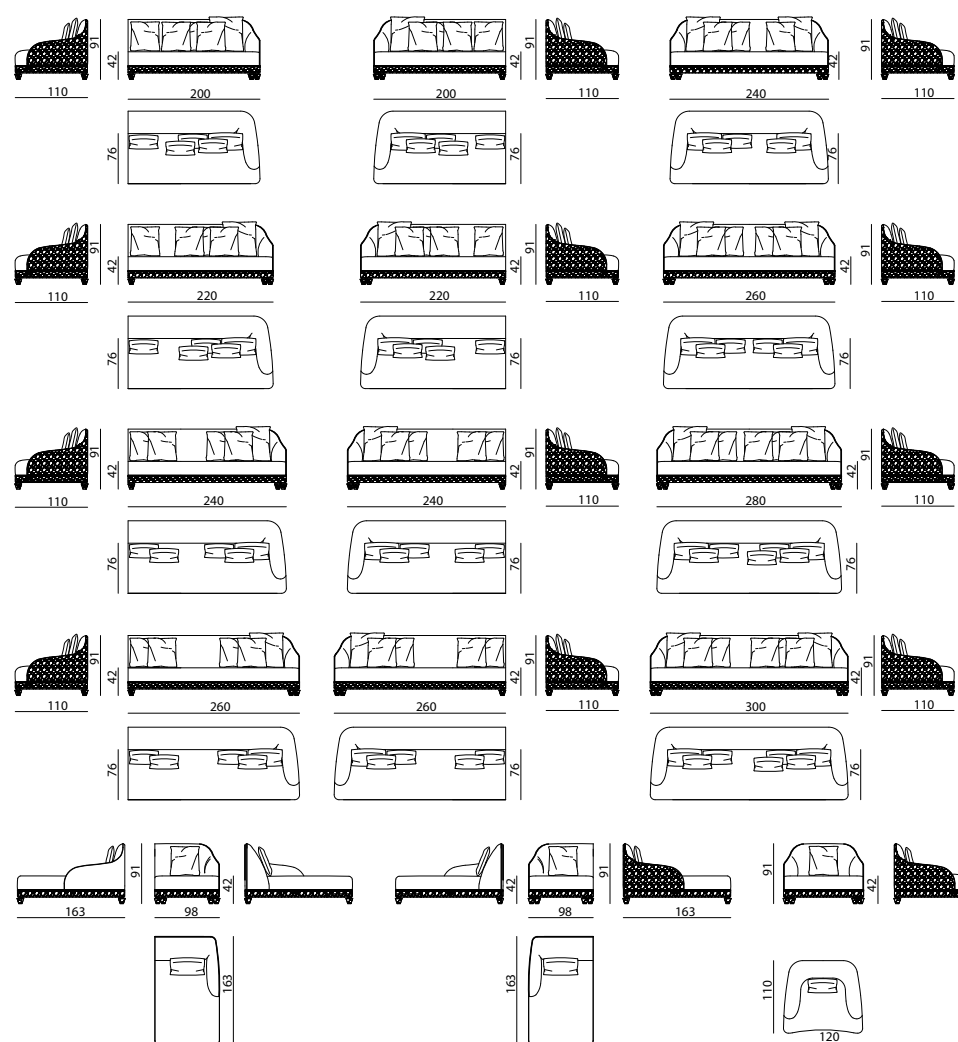

CHATAM CURVO

DIVANO, ELEMENTI COMPONENTI, POLTRONA, POUF,
TAVOLINO BASSO

SOFA, MODULAR ELEMENTS, ARMCHAIR, POUF, LOW TABLE
Alessandro La Spada

Scocca portante in multistrati e masselli di legno, schienale sagomato e cuscino seduta con tappezzeria fissa, molleggio a cinghie elastiche, imbottitura in poliuretano espanso a quote differenziate. Sedile con Memory Foam® e rombo-therm, rivestimento esterno e interno in pelle o tessuto, piedi in fusione di alluminio con texture "crocco" in bassorilievo, decorazione sul basamento e bordo dei braccioli con cerniera zip in ottone. Il divano è accessoriatato con cuscini 45x45 cm e cuscini 55x55 cm, il cui numero varia in base alle dimensioni. Sono disponibili: un pouf rettangolare ed uno curvo abbinato alla poltrona, con struttura in multistrati e masselli di legno; cuscino seduta con tappezzeria fissa e molleggio a cinghie elastiche; imbottitura in poliuretano espanso a quote differenziate; rivestimento in pelle o tessuto. I piedi sono in fusione di alluminio con texture "crocco" in bassorilievo, decorazione sul basamento con cerniera in ottone. Cerniere in finitura oro oppure cromo, ottone anticato o nichel nero. I piedi sono disponibili nella selezione finiture metalliche.

Bearing body in plywood and solid wood, shaped backrest and seat cushion with fixed upholstery, spring system with straps, padding in polyurethane foam in different densities. Memory Foam® and rombo-therm seat, internal and external upholstery in leather or fabric, feet in aluminium casting "crocodile" engraving texture in bas-relief, base and armrest edge decoration with zipper in brass. The sofa includes 45x45 cm and 55x55 cm cushions, quantity changes according to the dimensions of the sofa. Available: one rectangular pouffe and one shaped pouffe combined with the armchair; structure in plywood and solid wood, seat with fixed upholstery, spring system with straps, padding in polyurethane foam in different densities, upholstery in leather or fabric. Feet in aluminium casting "crocodile" engraving texture in bas-relief, base decoration with zipper in brass. Zippers in gold or chrome, antiqued brass or black nickel. Feet available in chrome, gold, champagne, bronze, Siena, black nickel and gunmetal finishing.

vedi anche/see also CHATAM tavolo da pranzo-dining table, CHATAM tavolino-low table, CHARLES tavolo basso-low table

● click here

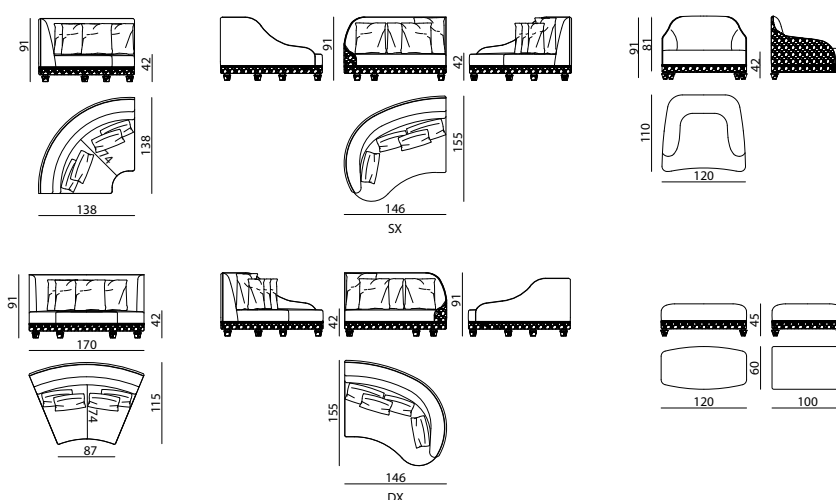

CHARLES

TAVOLO BASSO - LOW TABLE

Alessandro La Spada

Tavolo basso tappezzato in pelle o tessuto, top in marmo incassato in una cornice a sezione ellittica in ottone cromato, impreziosita da inserti con logo Visionnaire. Cerniera decorativa con cursori in pelle con logo, struttura interna in legno. Cerniere e cursori oro oppure cromo. Le parti metalliche sono disponibili nella selezione finiture metalliche.

Low table upholstered in leather or fabric, marble top built in a chromed-brass elliptical frame, enriched by inserts with Visionnaire engraved logo. Decorative zipper with sliders in leather with logo embroidered, internal structure in wood. Zippers and sliders in gold or chrome. Metal parts can be lacquered in any colour included in the metal finish selection.

● click here





CITIZEN CITIZEN ACTION

DIVANO, DIVANO CON UN BRACCIOLO,
POLTRONA - SOFA, ONE-ARMREST SOFA,
ARMCHAIR

Mauro Lipparini

Struttura interna in legno massello e multistrati. Con molleggio a cinghie elastiche, imbottitura del sedile, schienale e braccioli in poliuretano espanso a densità differenziate, Memory Foam® e falda acrilica. Rivestimento in pelle o tessuto. Basamento ligneo rivestito in acciaio inox satinato. Nella versione con un bracciolo, fregio decorativo sulla parte inclinata dello schienale in acciaio inox satinato, con logo in ottone cromato. Le parti in metallo sono disponibili nella selezione finiture metalliche satinato. Su richiesta, sono disponibili cuscini volanti tondi Ø35 cm e rettangolari 35x40 cm in piuma, rivestiti in pelle o tessuto, con filetto.

Disponibile in versione CITIZEN ACTION con rivestimento a lavorazione canneté su seduta e schienale.

Internal structure in solid wood and plywood, equipped with spring system with straps; seat, backrest and armrests padded in polyurethane foam in different densities, Memory Foam® and acrylic fibre. Upholstery in leather or fabric. Wooden base coated in satinized stainless steel. In the one-armrest version, decorative coat of arms on the oblique part of the backrest in satinized stainless steel. Metal parts available in the satinized metal finishing selection. Upon request, available loose round cushions Ø35 cm and rectangular cushions 35x40 cm filled in feather, upholstered in leather or fabric. Available in ACTION version, with seat and back upholstery finished with canneté quilted motif.

vedi anche/see also CITIZEN chaise-longue, CITIZEN pouf-round pouffe

click here

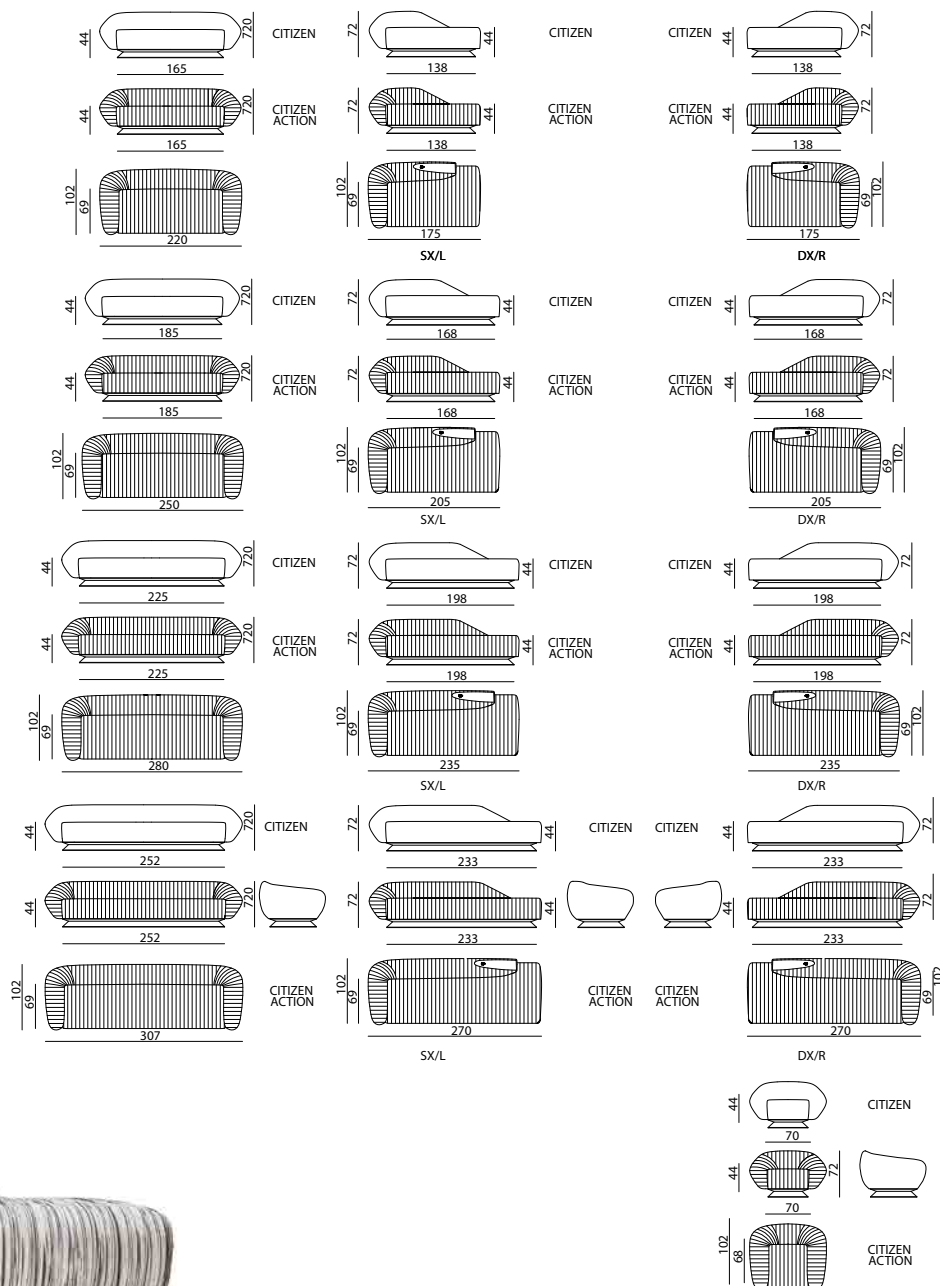

DENZEL

DIVANO, ELEMENTI COMPONENTI, POLTRONA
SOFA MODULAR ELEMENTS, ARMCHAIR
Fabio Bonfà

Divano tappezzato in pelle o tessuto, con base composta da un telaio in acciaio inox satinato e un pannello in legno e metallo rivestito in pelle o tessuto, dotato di cinghie elastiche per il molleggio dei sedili. Braccioli e schienali in legno massello e multistrati tappezzati in pelle o tessuto bordati con filetti. Cuscini di seduta in poliuretano a diverse densità, Memory Foam® e piuma. Cuscini di schienale e interno bracciolo in poliuretano e piuma, cuscini volanti in piuma. Le parti in metallo sono disponibili nella selezione finiture metalliche.

Sofa upholstered in leather or fabric. Base consisting of frame in satin stainless steel and panel in wood and metal upholstered in leather or fabric, equipped with elastic belt spring system. Armrests and backrest in solid wood and plywood upholstered in leather or fabric, decorated with piping. Seat cushions in polyurethane with different densities, Memory Foam® and feather. Back cushions and internal part of armrests in polyurethane and feather, loose cushions in feather. Metal components can be finished with any lacquer of the metal lacquer finish selection.

click here

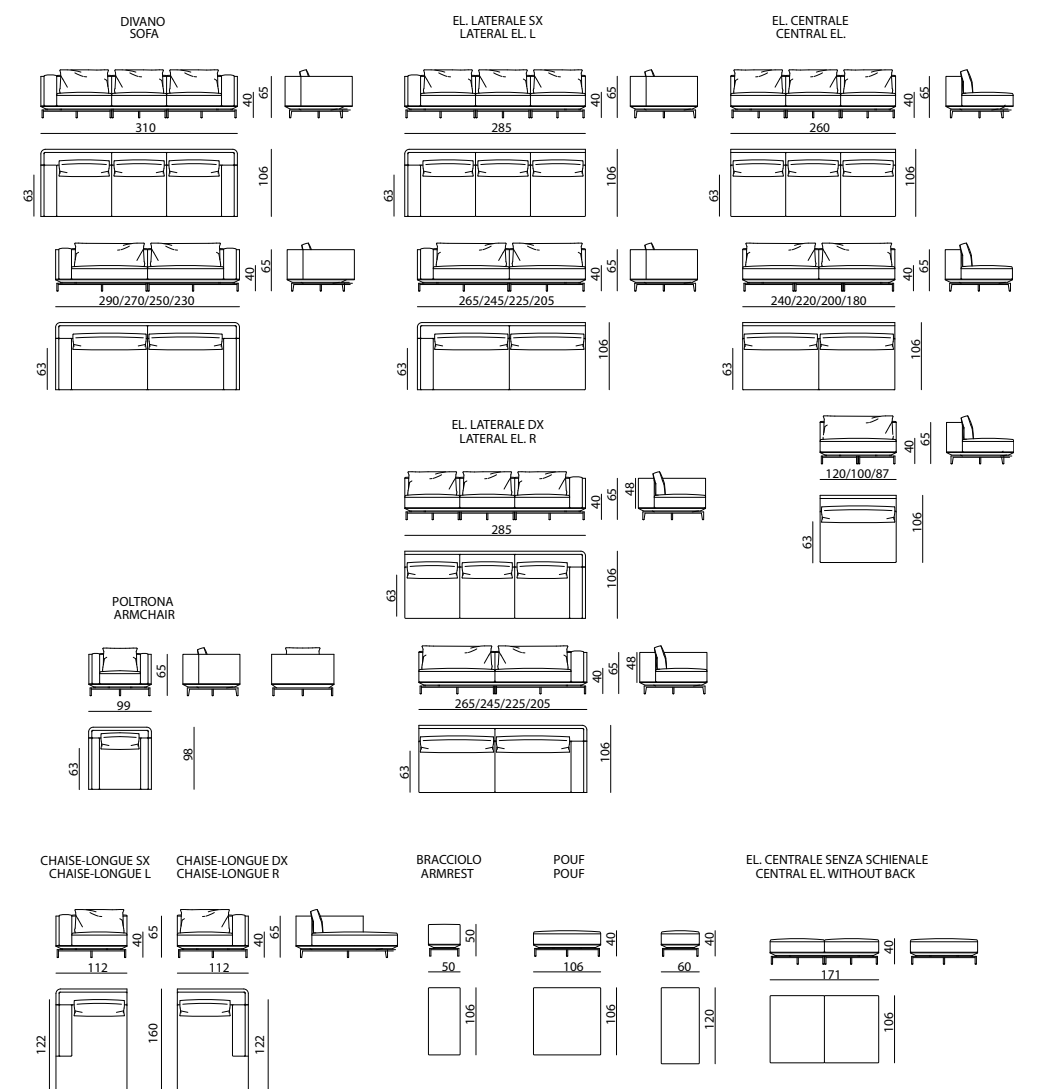



DEIMOS

DIVANO, POLTRONA - SOFA, ARMCHAIR

Steve Leung

Divano e poltrona tappezzati in pelle o tessuto. Fusto in legno curvato e sagomato in masselli e multistrati, rivestito esternamente in poliuretano rigido sagomato con superfici esterne concave e curvate. Interno braccioli e schienale in poliuretano bombato e sedile in poliuretano a densità differenziate e falda acrilica, con molleggio a cinghie elastiche. Scocca portante in legno di frassino massello tinto opaco, con basette in acciaio. Disponibile in opzione scocca in legno di frassino massello tinto lucido 100 gloss.

Sofa and armchair upholstered in leather or fabric. Curved and shaped frame in solid and multiply wood, externally covered in rigid shaped polyurethane with concave and curved external surfaces. Internal armrests and backrest in convex polyurethane and seat in polyurethane with variable density and acrylic layer, with elastic belt springing. Body in mat lacquered ash solid wood, with steel feet. Optionally available solid ash wood shell stained 100 gloss.

vedi anche/see also DEIMOS dormeuse

● [click here](#)

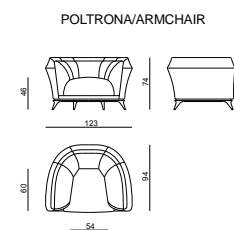
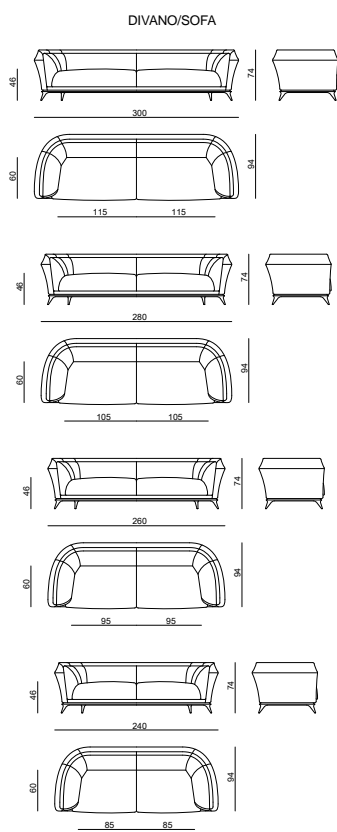



DONOVAN ROLL

DIVANO, ELEMENTI COMPONENTI, POUF

SOFA, MODULAR ELEMENTS, POUF

La Conca

Divano tappezzato in pelle o tessuto, con fusto composto da un telaio in legno massello dotato di cinghie elastiche. La base in multistrati rivestito in tessuto (Gand, Faber o Vermeer) trapuntato canneté sostiene le sedute e lo schienale. Piedi formati da cilindri metallici con logo Visionnaire in rilievo. Braccioli composti da elementi cilindrici tappezzati e rifiniti con cinghie in pelle e passanti metallici. Cuscini di seduta in poliuretano a densità differenziate, Memory Foam® e piuma. Cuscini di schienale in poliuretano e piuma, cuscini volanti in piuma. Versione componibile disponibile con elementi centrali, angolari e laterali. Le parti in metallo sono disponibili nelle finiture cromo, oro, champagne, Siena, canna di fucile e nichel nero.

Sofa upholstered in leather or fabric, frame in wood with elastic spring belts. Back and armrests in polyether and padded in feather. Base in plywood upholstered in fabric (Gand, Faber or Vermeer) with canneté quilted decoration. Cylindrical metal feet with Visionnaire logo in relief. Armrests consists of cylindrical elements upholstered and decorated with leather belts and metal buckles. Seat cushions padded in polyurethane foam with different densities, Memory Foam® and feather sewed to the external upholstery; loose cushions padded in feather. Modular version includes central, corner and lateral elements. Metal parts can be lacquered with chrome, gold, champagne, Siena, gunmetal grey or black nickel finish.

● [click here](#)

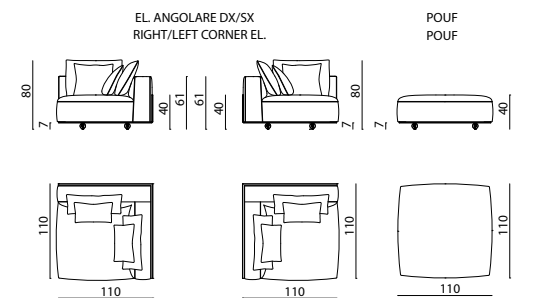
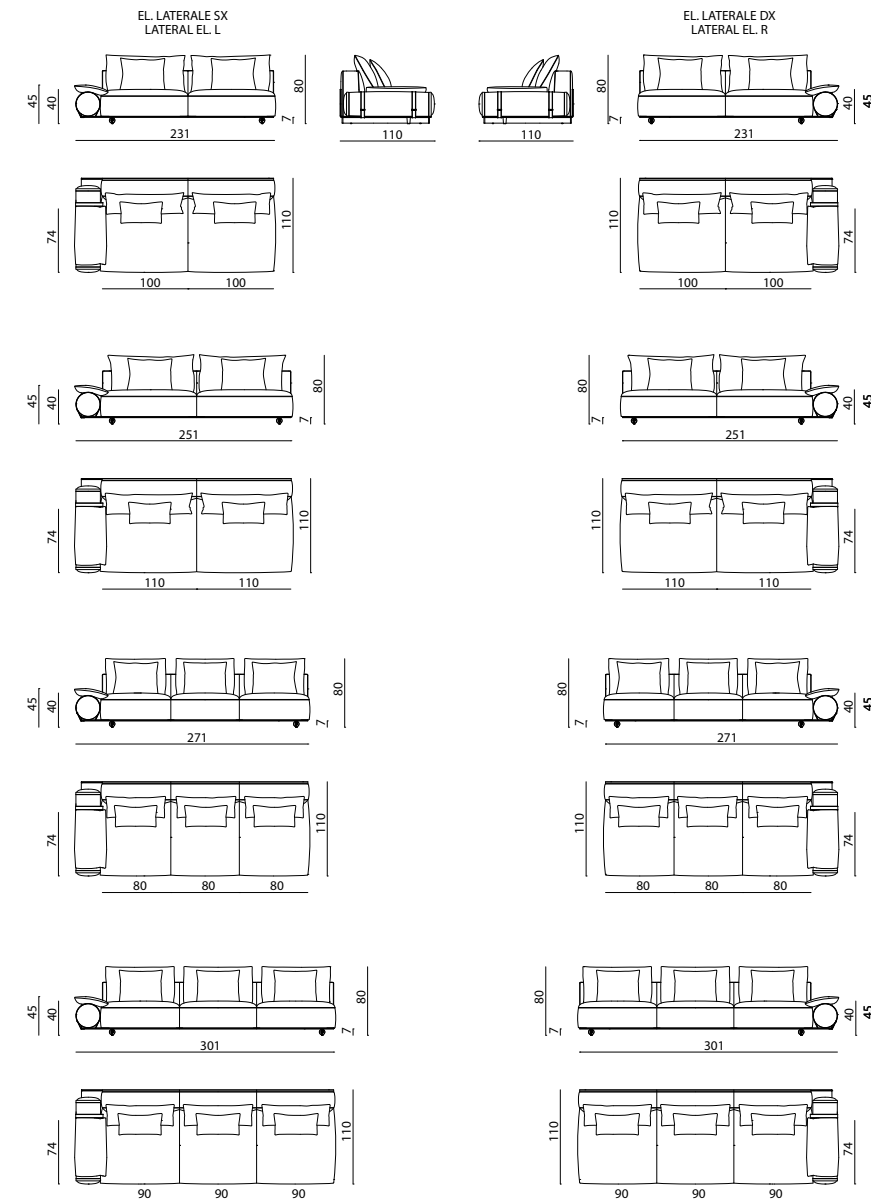
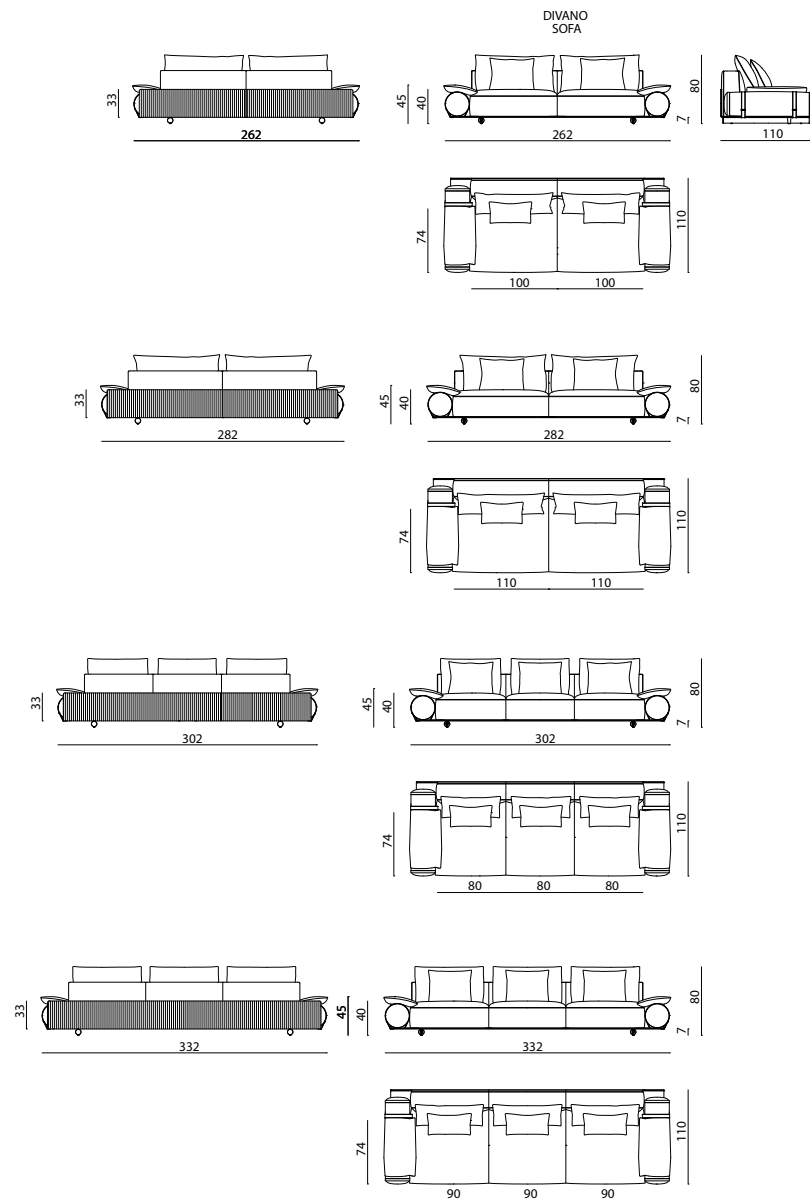



DONOVAN SQUARE

DIVANO, ELEMENTI COMPONENTI, POUF
SOFA, MODULAR ELEMENTS, POUF

La Conca

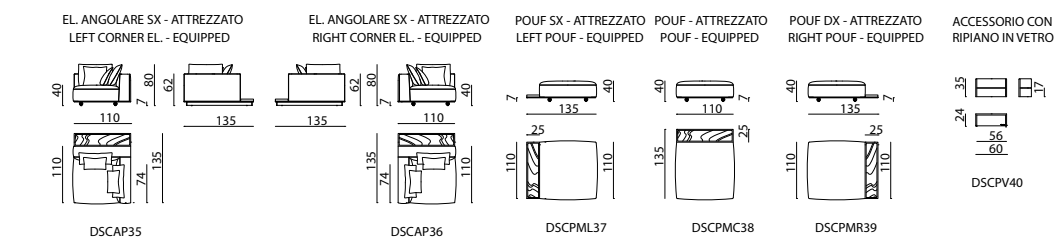
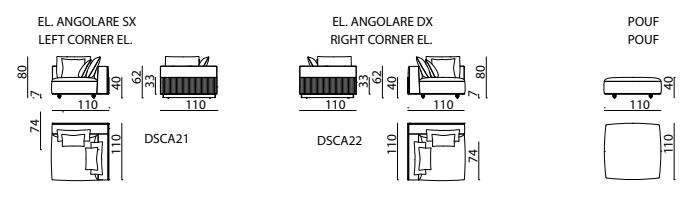
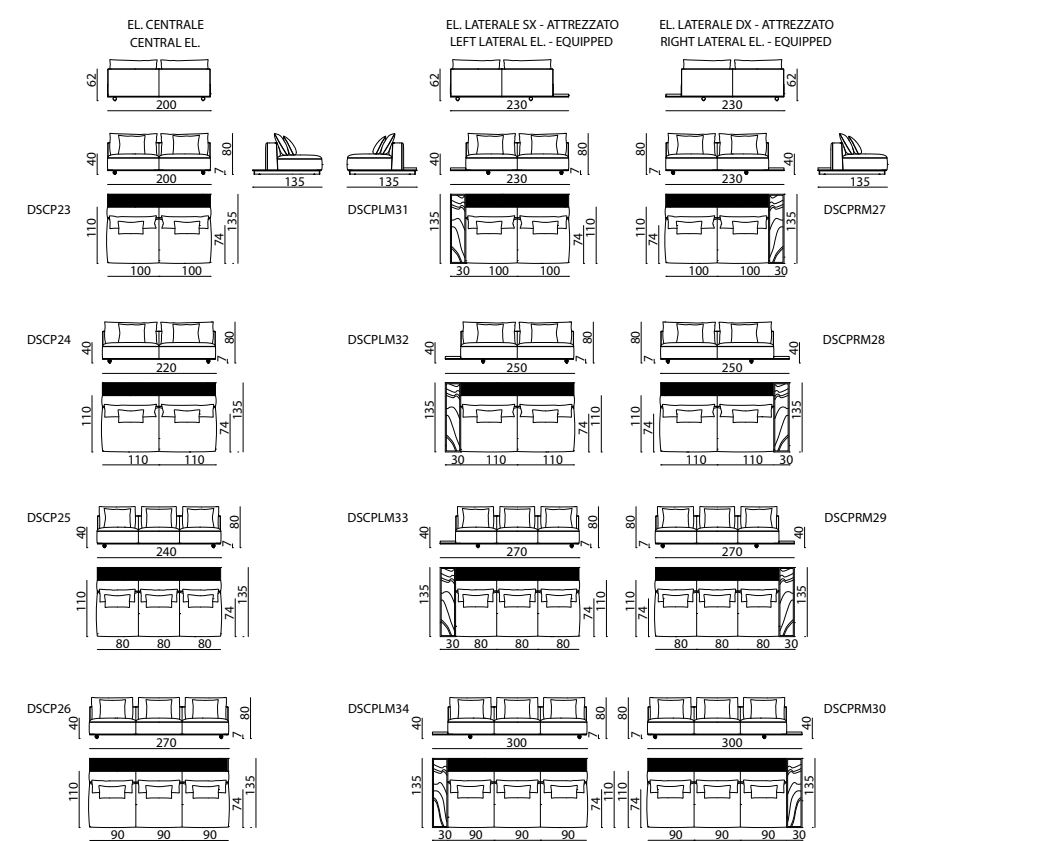
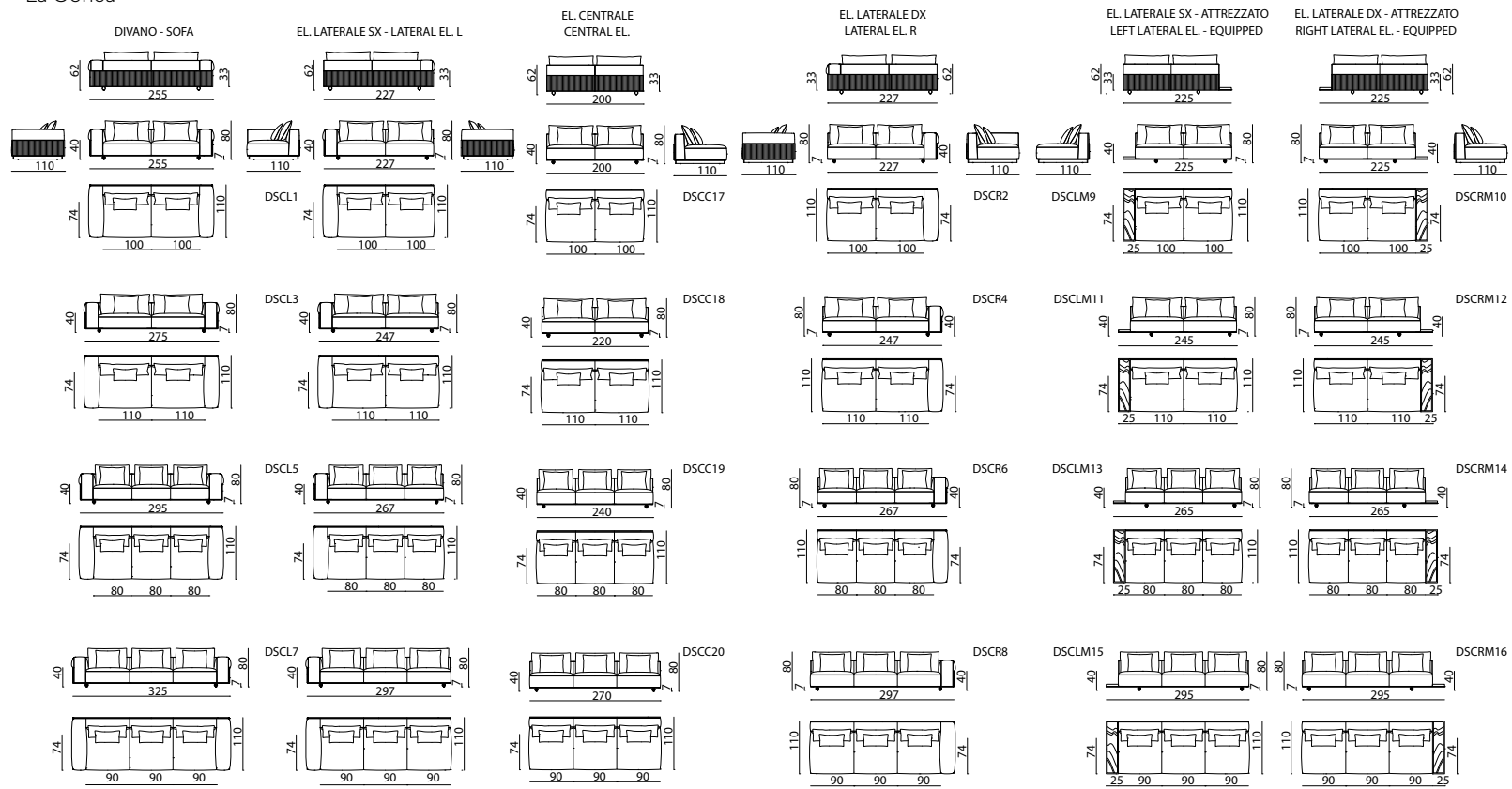

Divano tappezzato in pelle o tessuto, con fusto composto da un telaio in legno dotato di cinghie elastiche. Schienali e braccioli in poliuretano e piuma nella parte interna. Cuscini di seduta in poliuretano a quote differenziate, Memory Foam® e piuma cucita al rivestimento esterno, cuscini volanti in piuma. I divani sono racchiusi da scocche in legno multistrati tappezzati in tessuto (Gand, Faber o Vermeer) trapuntato canneté. Piedi formati da cilindri metallici con logo Visionnaire in rilievo. Disponibile anche a profondità maggiorata attraverso un prolungamento della base posteriore che può ospitare tavolini in marmo bordati in pelle e/o piccoli vani libreria in pelle con ripiano in vetro. Versione componibile disponibile con elementi centrali, angolari e laterali. Le parti in metallo sono disponibili nelle finiture cromo, oro, champagne, Siena, canna di fucile e nichel nero.

Sofa upholstered in leather or fabric, frame in wood with elastic spring belts. Back and armrests in polyether and padded in feather. Seat cushions padded in polyurethane foam with different densities, Memory Foam® and feather sewed to the external upholstery; loose cushions padded in feather. The sofas are embraced by an external structure in plywood covered in fabric (Gand, Faber or Vermeer) with canneté quilted decoration. Cylindrical metal feet with Visionnaire logo in relief. Available with increased depth by means of an extension of the rear base, which can fit small tables in marble with leather piping and/or small book shelves in leather with glass shelf. Modular version includes central, corner and lateral elements. Metal parts can be lacquered with chrome, gold, champagne, Siena, gunmetal grey or black nickel finish.

● click here



DOUGLAS

DIVANO, ELEMENTI COMPONENTI, DORMEUSE, CHAISE-LONGUE, POUF, CONSOLLE, TAVOLO BASSO

SOFA, MODULAR ELEMENTS, DORMEUSE, CHAISE-LONGUE, POUF, CONSOLLE, LOW TABLE

Alessandro La Spada

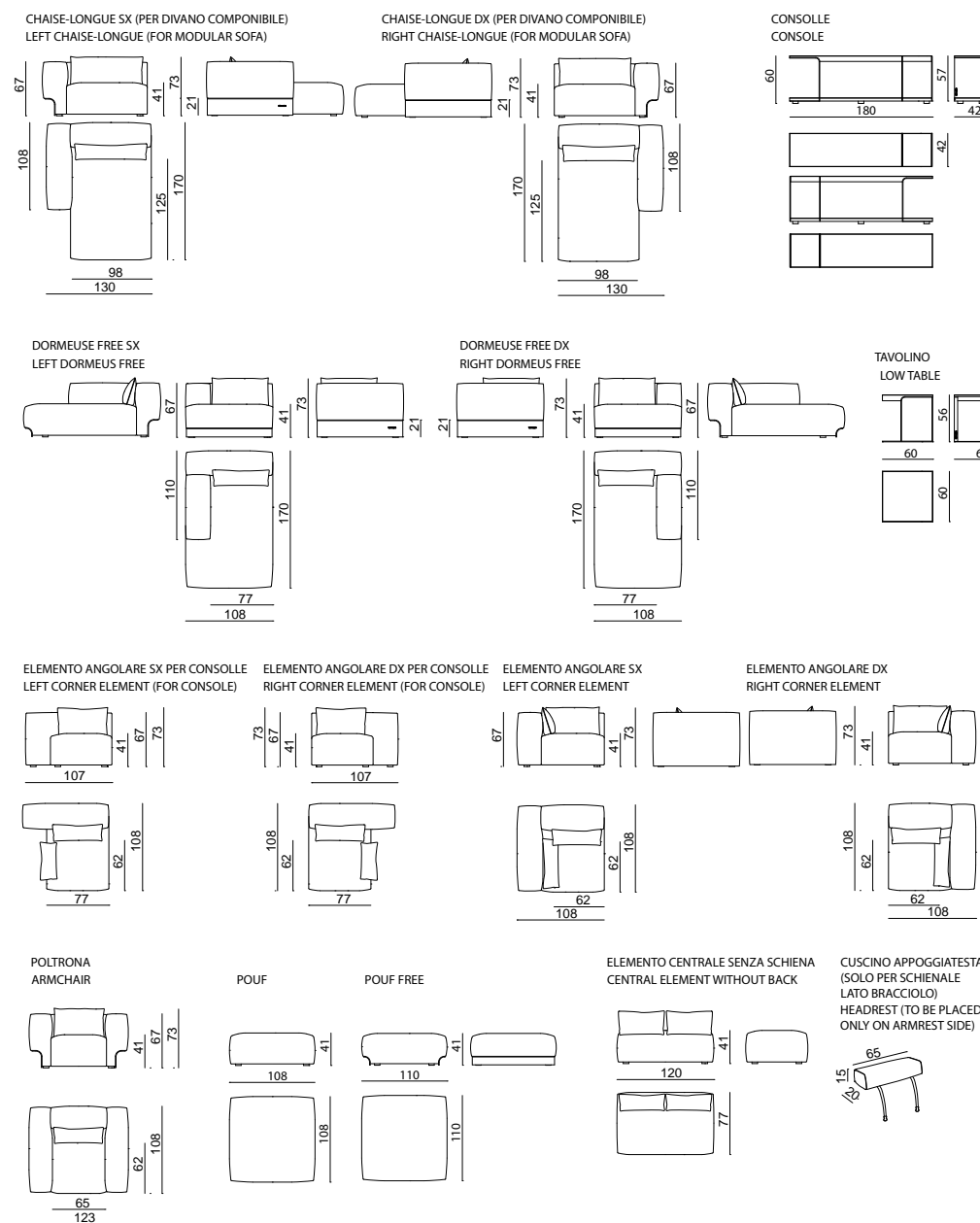
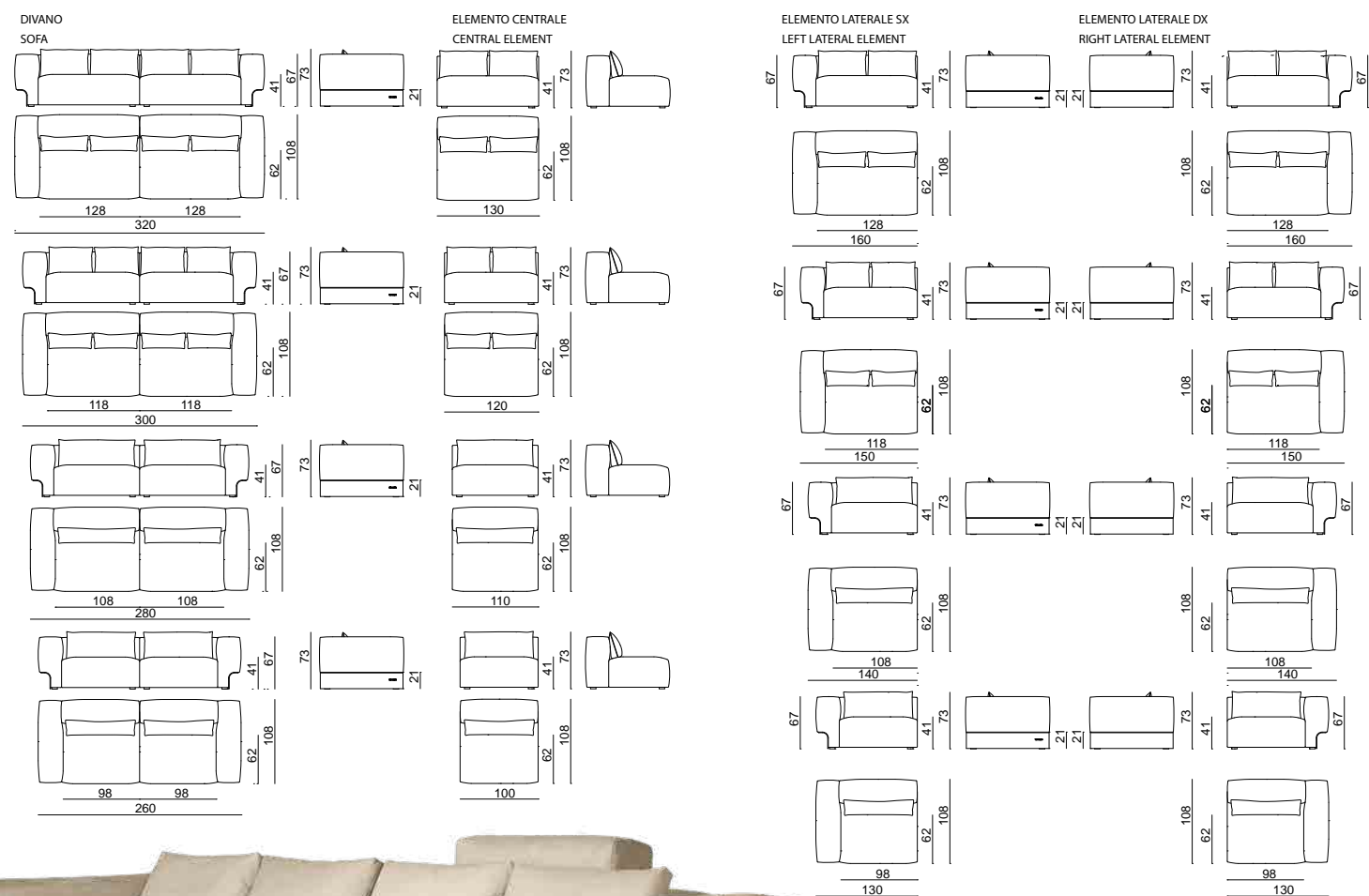

Divano tappezzato in pelle o tessuto. I braccioli sono caratterizzati da elementi curvi in metallo lucido di forte spessore, posti sui fianchi in corrispondenza dei piedi. Fusto in legno dotato di cinghie elastiche per il molleggio dei sedili. Braccioli e schienale squadrati di grandi dimensioni con superficie esterna in falda acrilica soffice sotto il rivestimento. Cuscini di seduta in poliuretano a densità differenziate, Memory Foam® e piuma. Cuscini di schienale e interno bracciolo in poliuretano e piuma, cuscini volanti in piuma. Nella versione in tessuto i cuscini di seduta, gli schienali e i braccioli hanno i filetti in tessuto Kale. Le parti metalliche sono disponibili nella selezione finiture metalliche lucide. Versione componibile disponibile con elementi centrali e laterali e consolle bassa in alluminio lucido e top in legno rivestito in essenza o laccato lucido (tinte RAL/NCS) con funzione di ripiano e schienale.

Sofa upholstered in leather or fabric. Armrests consist of curved metal elements with polish finish and high thickness positioned on the sides of the sofa, next to the feet. Frame in wood equipped with elastic spring belts on the seats. Squared armrests and backrests with large dimensions, with a layer of soft acrylic fiber under the upholstery. Seat cushions padded in polyurethane foam with different densities, Memory Foam® and feather. Back cushions and internal armrest padded in polyurethane foam and feather, loose cushions in feather. When upholstered in fabric, seat cushions, internal backrests and armrests have piping in Kale fabric. Metal parts can be lacquered in any colour of the polish metal finish selection. Modular version including central and lateral elements, and low console in polished aluminium and top in wood with veneered or lacquered finish (RAL/NCS colours), as a backrest and shelf.

vedi anche/see also DOUGLAS tavolino-small table, DOUGLAS consolle-console

● click here





FITZGERALD

DIVANO - SOFA

La Conca

Divano con scocca in legno e tappezzeria in pelle o tessuto. Scocca esterna in multistrati di pioppo curvato e sagomato, impiallacciata in essenza con bordo in metallo su tutto il perimetro. Struttura di base in multistrato di pioppo, telaio sedile cinghiato con nastri elastici incrociati. Cuscini di seduta in poliuretano espanso a densità differenziate e Memory Foam®, coperti da un guscio di piuma. Cuscino di seduta sfoderabile. Imbottitura dei braccioli con tampone superiore ad alta densità. Cuscini schienale in piuma con anima interna in poliuretano elastico. Cuscini di spalliera sfoderabili. Le parti in legno sono disponibili lucide 100 gloss nelle finiture selezione essenze e in Radica. Le parti metalliche sono disponibili nella selezione finiture metalliche.

Sofa with wooden structure and upholstery in leather or fabric. External structure made in curved and shaped poplar plywood, coated in veneer and decorated with a metal profile framing the perimeter. Base structure in poplar plywood, seat frame supported by interwoven elastic belts. Seat cushions padded with expanded polyurethane foam with different densities and Memory Foam®, topped by a layer of feather. Back cushions with removable covers. Wooden parts available in any of the polished finishes included in the wood veneer selection or in Radica. Metal parts available in any of the lacquers included in the metal finish selection.

vedi anche/see also FITZGERALD tavolo basso-low table

[click here](#)

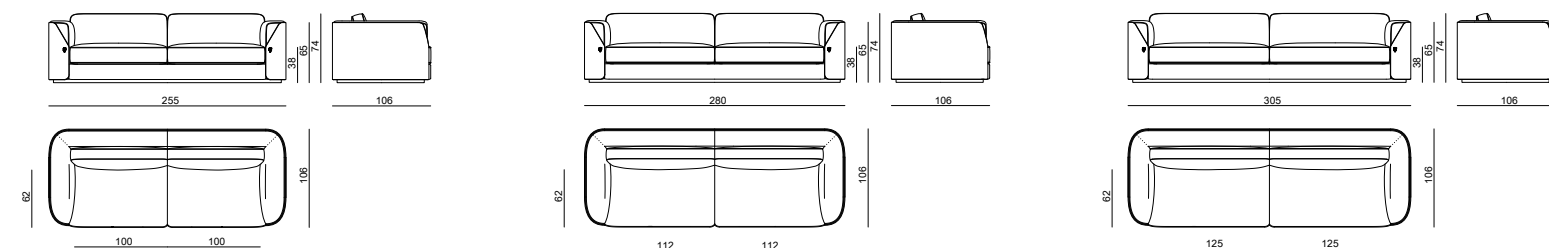

FREYR

DIVANO, POLTRONA - SOFA, ARMCHAIR

Steve Leung

Struttura in legno multistrati curvato, molleggio con cinghie elastiche, basamento in legno di faggio laccato lucido (colori RAL) e piedini in acciaio; imbottitura in poliuretano espanso a densità differenziate, cuscini di seduta in poliuretano espanso, Memory Foam® e piuma d'oca. Rivestimento fisso in pelle o tessuto, lavorazione interno schienale capitonné.

Disponibile versione FREYR RADICA con scocca esterna rivestita in radica con finitura lucida 100 gloss.

Curved structure in solid wood and plywood, sprung system with elastic bands, base in glossy lacquered beech wood (RAL colours) and steel feet; padding in polyurethane foam in different densities, seat cushions in polyurethane foam, Memory Foam® and goose down. Fixed cover in leather or fabric, internal backrest capitonné finishing.

Available FREYR RADICA version with external shell covered in burr walnut with 100 gloss finish.

[click here](#)

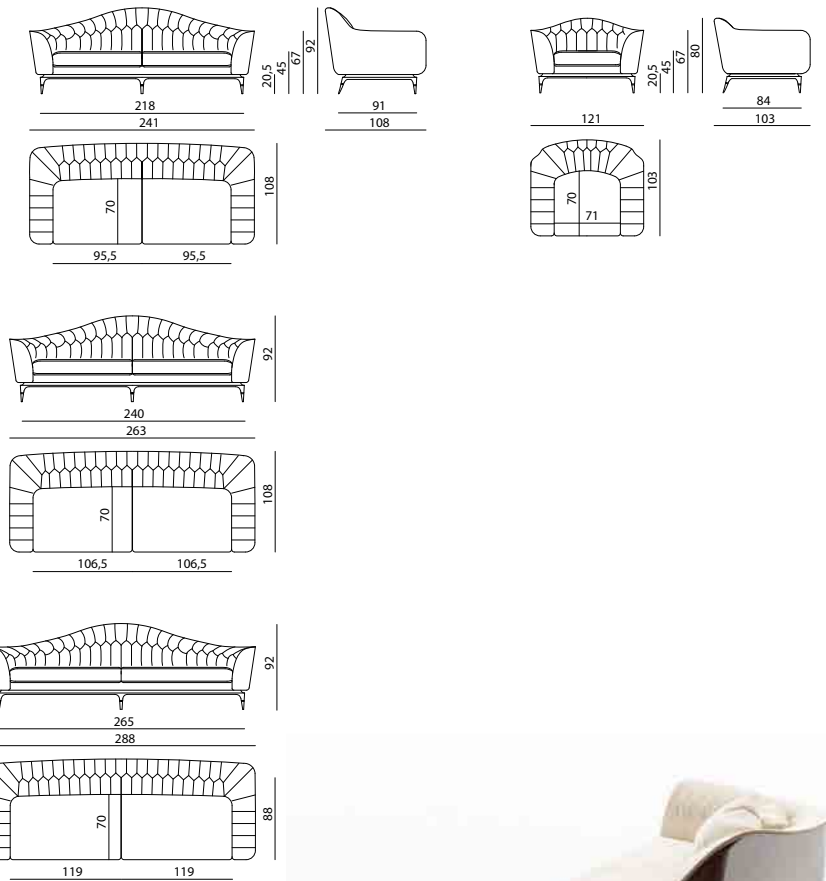

VERSIONE RADICA/ RADICA VERSION



FOSTER

DIVANO, ELEMENTI COMPONENTI, POLTRONA
 SOFA MODULAR ELEMENTS, ARMCHAIR
 Alessandro La Spada

Divano tappezzato in pelle o tessuto, fusto in legno massello e multistrato composto da una scocca con molleggio a cinghie elastiche per il sedile e da elementi curvi imbottiti per braccioli e schienale. Imbottitura in poliuretano a densità differenziate. Cuscini di schienale in piuma. Rivestimento esterno di fianchi e schienale con lavorazione trapuntata a canneté verticale. Zoccolo rivestito in metallo, disponibile in colore cromo satinato, oro satinato e siena satinato.

Sofa covered in leather or fabric. Main structure in solid and multiply wood consisting of a frame with elastic belt springing for seat and of curved padded elements for armrests and backrest. Padding in polyurethane with variable density. Seat cushions in feather. External sides and rearback with vertical canneté quilting. Plinth covered in metal, available in satin chrome, satin gold and satin siena.

vedi anche/see also FOSTER tavolo basso-low table, FOSTER dormeuse

● [click here](#)

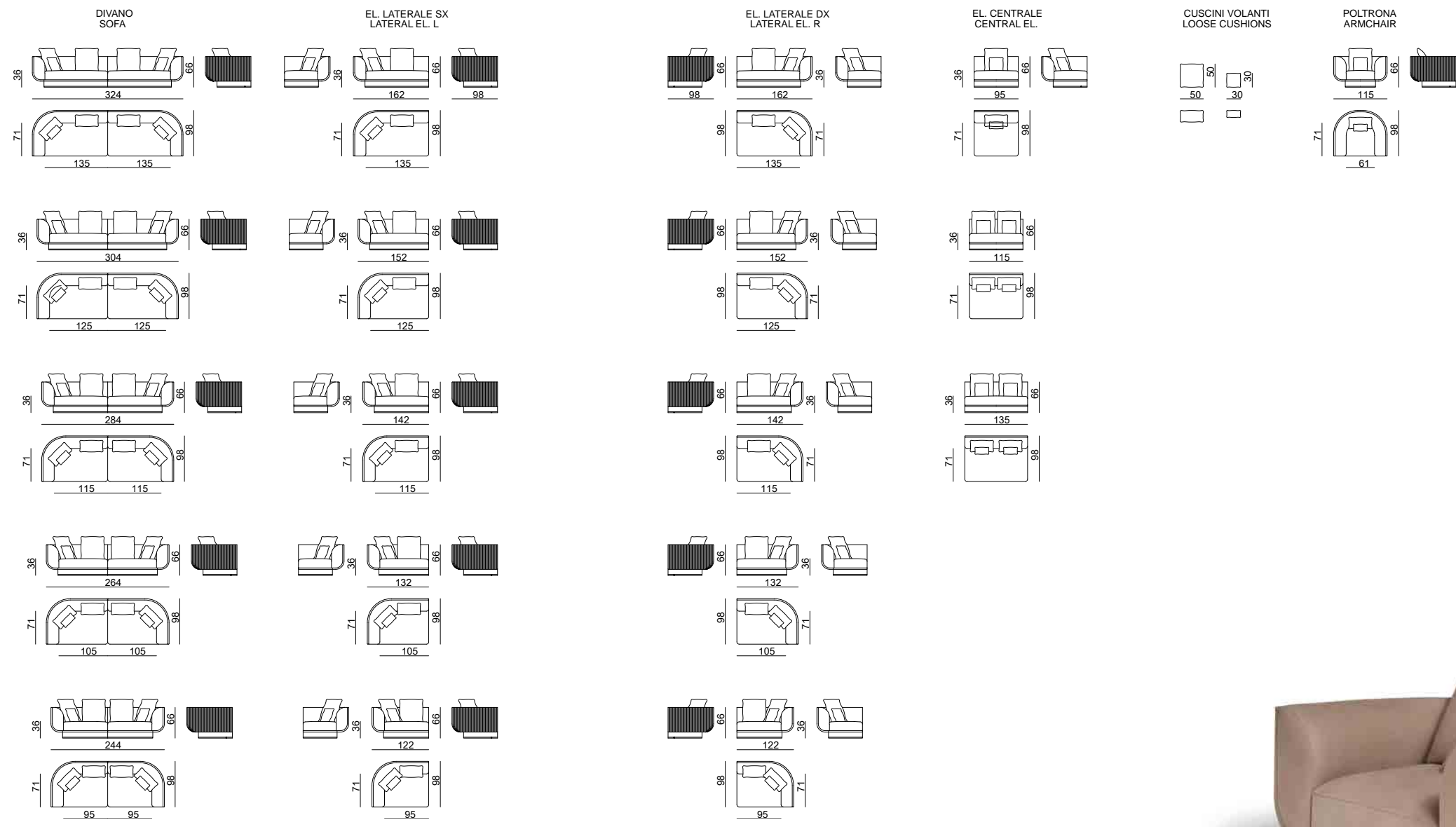



HAGAL

DIVANO, POLTRONA - SOFA, ARMCHAIR

Steve Leung

Scocca in multistrati curvato e masselli in pioppo e faggio, schienale rivestito posteriormente in pelle o tessuto e imbottito anteriormente in poliuretano a densità differenziate tappezzato a losanghe. Base molleggiata con cinghie elastiche, con profilo decorativo in alluminio satinato e piedi in alluminio tornito cromato. Cuscini di seduta in poliuretano, Memory Foam® e piuma d'oca, rulli reggi-reni in piuma d'oca. Le parti metalliche sono disponibili nella selezione finiture metalliche.

Curved plywood structure in solid poplar and beech wood, backrest covered externally with leather or fabric. Internal backrest in polyurethane in different densities, upholstered in leather or fabric with diamond shaped quilting. Spring system with elastic straps decorative profile in brushed aluminium and feet in turned aluminium chromed. Seat cushions in polyurethane, Memory Foam® and goose down, roll cushions in goose down. Metal parts can be finished with any lacquer of the metal lacquer finish selection.

● [click here](#)

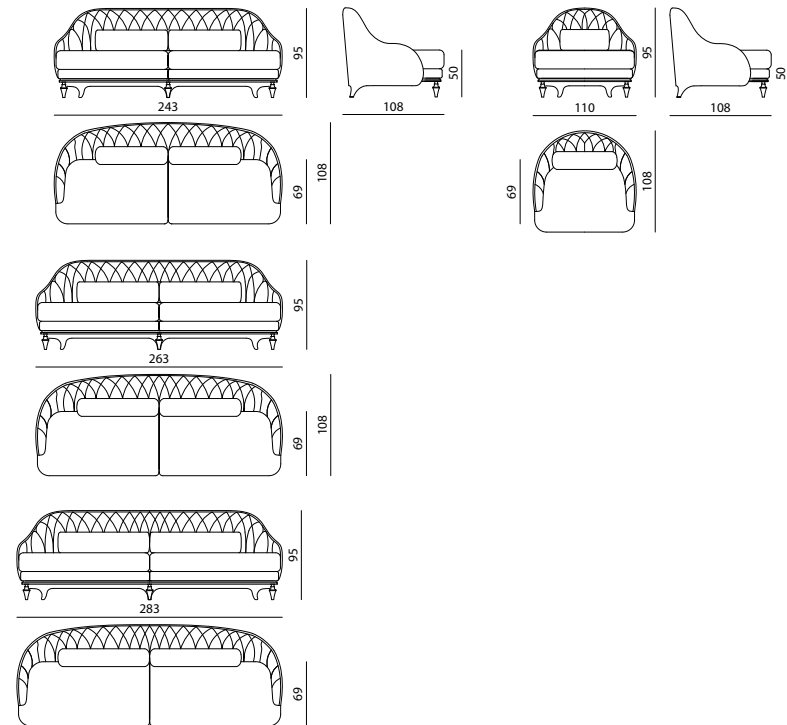

HEMINGWAY

DIVANO, POLTRONA - SOFA, ARMCHAIR

Samuele Mazza

Struttura interna in legno massello e multistrati di pioppo con molleggio a cinghie elastiche, imbottitura in poliuretano espanso a densità differenziate. Rivestimento in pelle o tessuto. Schienale e braccioli sagomati tappezzati internamente con pannelli imbottiti, rivestiti singolarmente. Cuscini di seduta in poliuretano a densità differenziate, Memory Foam® e piuma d'oca. Basamento, braccioli e schienale sono decorati con una cerniera disponibile in finitura oro, ottone anticato e nickel nero. Piedi in legno di faggio laccato opaco.

Internal structure in solid wood and poplar plywood, equipped with spring system with straps; padding in polyurethane foam in different densities. Upholstery in leather or fabric. Shaped back and armrests internally upholstered with individually padded panels. Seat cushions padded in polyurethane in different densities, Memory Foam® and goose down. Base, armrests and back decorated with zip, available in gold, antiqued brass or black nickel finishing. Feet in matt lacquered beech wood.

vedi anche/see also HEMINGWAY turca-ottoman, HEMINGWAY panca alta-high bench, HEMINGWAY letto-bed

● [click here](#)

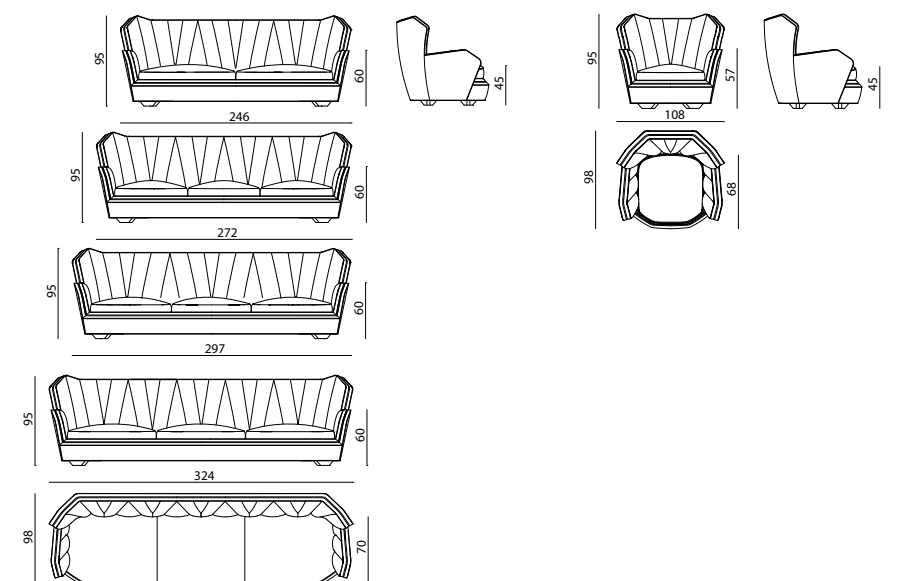



LEGEND

DIVANO, ELEMENTI COMPONIBILI, POLTRONA, CHAISE-LONGUE, POUF
 SOFA, MODULAR ELEMENTS, ARMCHAIR, CHAISE-LONGUE, POUFFE
 Fabio Bonfà

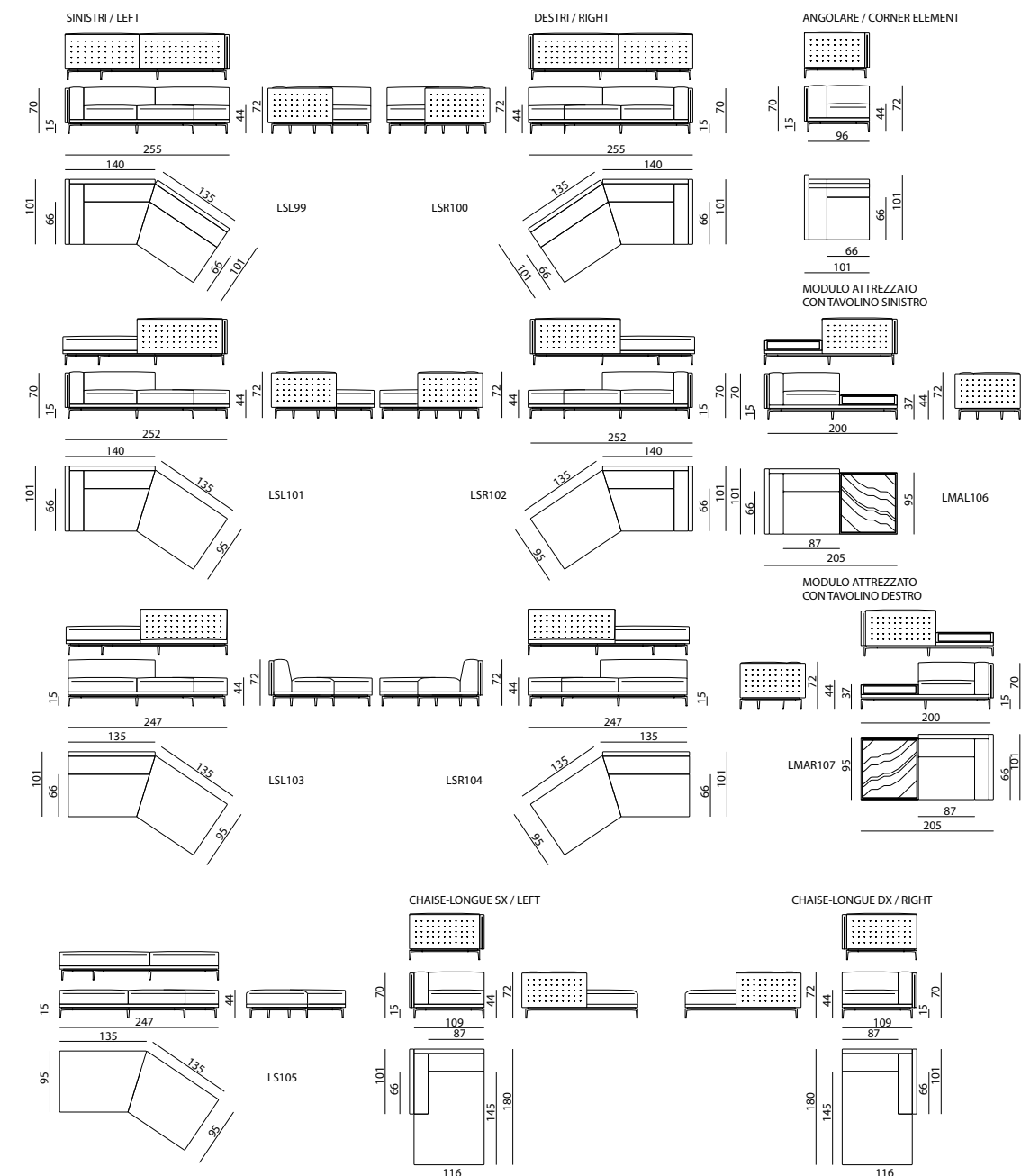
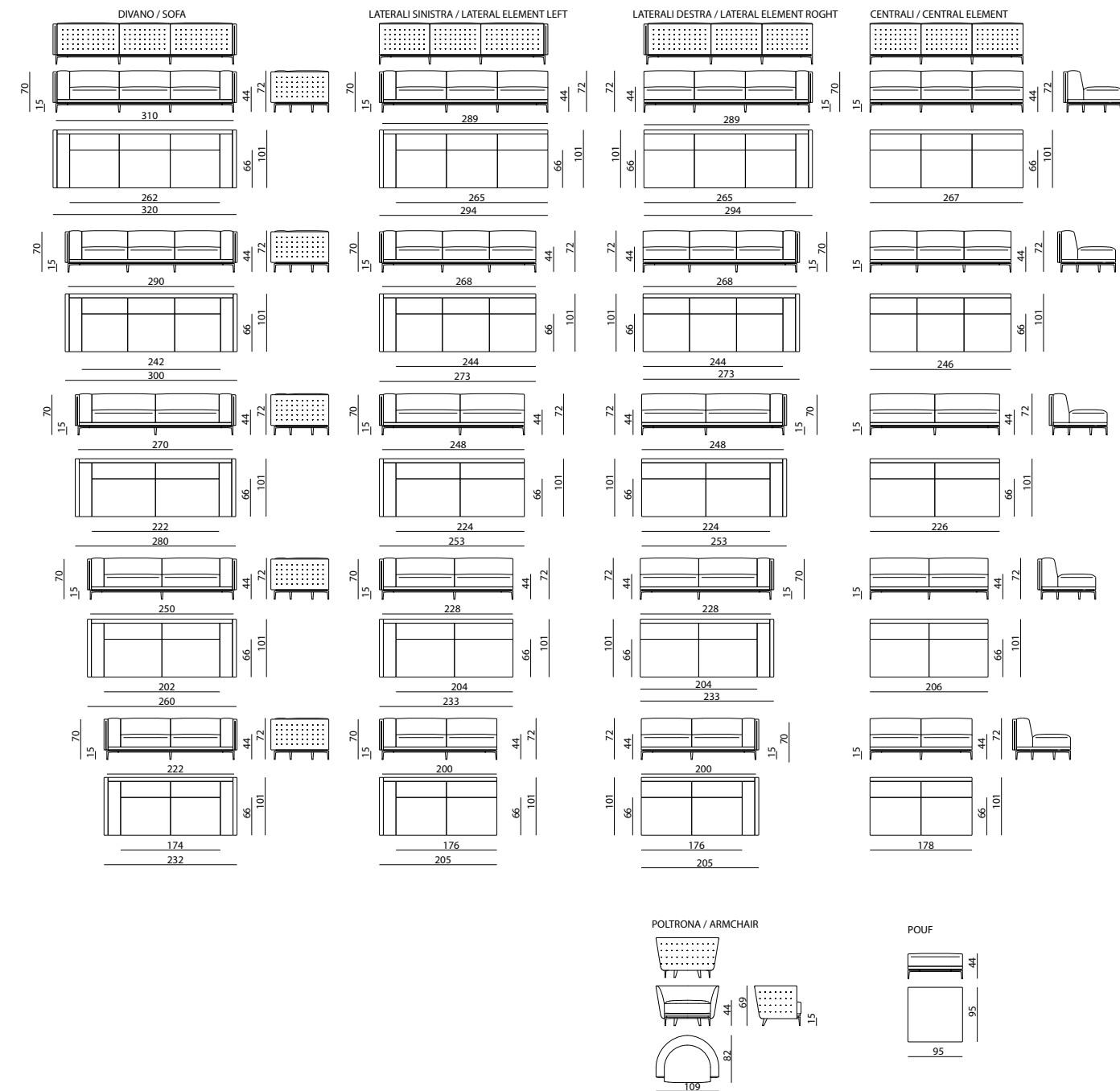

Struttura di base in multistrato di pioppo a doppio spessore rinforzata in metallo e cinghiatura elastica. Struttura schienali e braccioli in multistrato di pioppo con rivestimento "a portafoglio" in pelle o tessuto con lavorazione trapuntata a punti. Cuscini braccioli imbottiti con anima in poliuretano e lastra di Memory Foam®, incamerato in guscio di cotone anti-piuma riempito con miscela mista acrilico e piumino. Cuscini di seduta in poliuretano espanso a doppia densità ricoperto con lastra di Memory Foam® e guscio di cotone anti-piuma riempito in piumino. Rivestimento cuscini completamente sfoderabili. Base e piedi in acciaio inox satinato con lavorazione scalettata. Disponibile con tavolino laterale in legno rivestito in essenza laccata al poliuretano trasparente lucido, top in marmo e profilo frontale in acciaio satinato. La struttura è disponibile nella selezione finiture metalliche satinato. Disponibile pouf quadrato con struttura interna in legno, imbottitura in poliuretano a densità differenziate. Rivestimento in pelle o tessuto. Base e piedi in acciaio inox satinato sono disponibili nella selezione finiture metalliche.

Structure in poplar dual-layer plywood with steel reinforcement and elastic straps. Backrest and armrest structure in poplar plywood; wallet-like upholstery in leather or fabric with quilted decorative stitching. Armrests padded cushions with core in polyurethane and layer in Memory Foam®, embedded within a proof cotton lining, filled with a mix of acrylic fibre and down. Seat cushions in polyurethane foam with dual densities covered with a layer of Memory Foam® and embedded within a feather-proof lining, filled with down. Cushions upholstery completely removable. Base and feet in satinized stainless steel with stair-stepped working. Available also with lateral low table in wood covered in veneered wood finished with polyester based painting. Structure available in the satinized metal finishing selection. Also available pouffe with internal structure in wood, padded in polyurethane with different densities. Upholstery in leather or fabric. Base and feet in stainless steel are available in the satinized metal finishing selection.

vedi anche/see also LEGEND poltrona-armchair

● click here





JAMBOREE

DIVANO, POLTRONA - SOFA, ARMCHAIR
Alessandro La Spada

Divano, poltrona con tappezzeria fissa in pelle o tessuto, fusto in legno multistrati e massello con cinghiature elastiche, imbottitura in poliuretano a diverse densità, Memory Foam® e piuma. La scocca esterna è formata da pannelli leggermente imbottiti e rivestiti. Cuscini volanti in piuma. Piedi in acciaio inox con sagoma a coda di rondine. Le parti in metallo sono disponibili nella selezione finiture metalliche.

Sofa, armchair with non-removable upholstery in leather or fabric; frame in plywood and solid wood with elastic webbing belts; padding in polyurethane with different densities, Memory Foam® and feather. External structure consisting of slightly padded panel covered with upholstery. Loose cushions in feather. Feet in stainless steel with dove-tail shape. Metal parts can be finished in any lacquer of the metal lacquer finish selection.

vedi anche/see also JAMBOREE poltroncina-armchair, JAMBOREE tavolino-low table

● [click here](#)

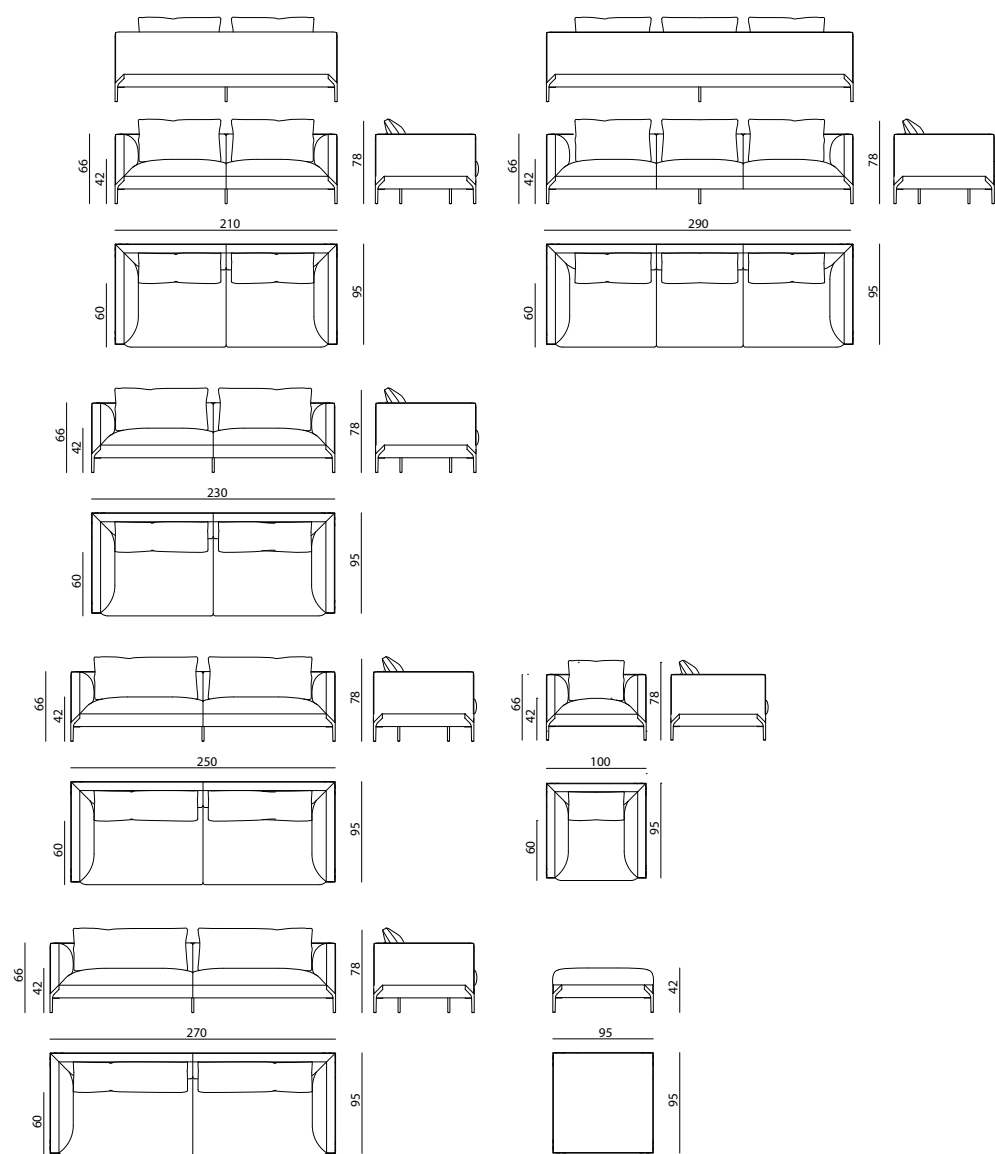

MEMPHIS

DIVANO - SOFA
La Conca

Divano in pelle o tessuto, fusto in multistrati e massello di legno con telaio di seduta molleggiato con cinghie elastiche. Imbottitura della scocca e cuscini di seduta in poliuretano a densità differenziate e faldati. I cuscini di schienale, il retro schienale e l'esterno dei braccioli sono decorati con piping in contrasto. In opzione, l'esterno dei braccioli può ospitare una tasca in pelle stampata per piccoli oggetti, con bordo in pelle e logo Visionnaire in ottone cromato. Filetti a contrasto in pelle. Elemento paraspiagioni con logo in acciaio inox e ottone cromato sotto il sedile. Piedi in acciaio inox con elementi tubolari sovrapposti. Le parti metalliche sono disponibili nella selezione finiture metalliche satiniate.

Sofa in leather or fabric, structure in plywood and solid wood, seat frame webbed with elastic belts. Padding of external structure and seat cushions in polyurethane with different densities and acrylic fiber. The back cushions, the rear back and the external part of the armrests are decorated with contrasting piping. In option, the external part of the armrest can be equipped with a pocket in printed leather suitable for small items and decorated with leather edge and Visionnaire logo in chromed brass. Contrasting piping in leather. Corner protectors with logo in stainless steel and chromed brass under the seat. Feet in stainless steel with overlying tubular elements. Metal parts available with satin metal lacquered finish.

● [click here](#)

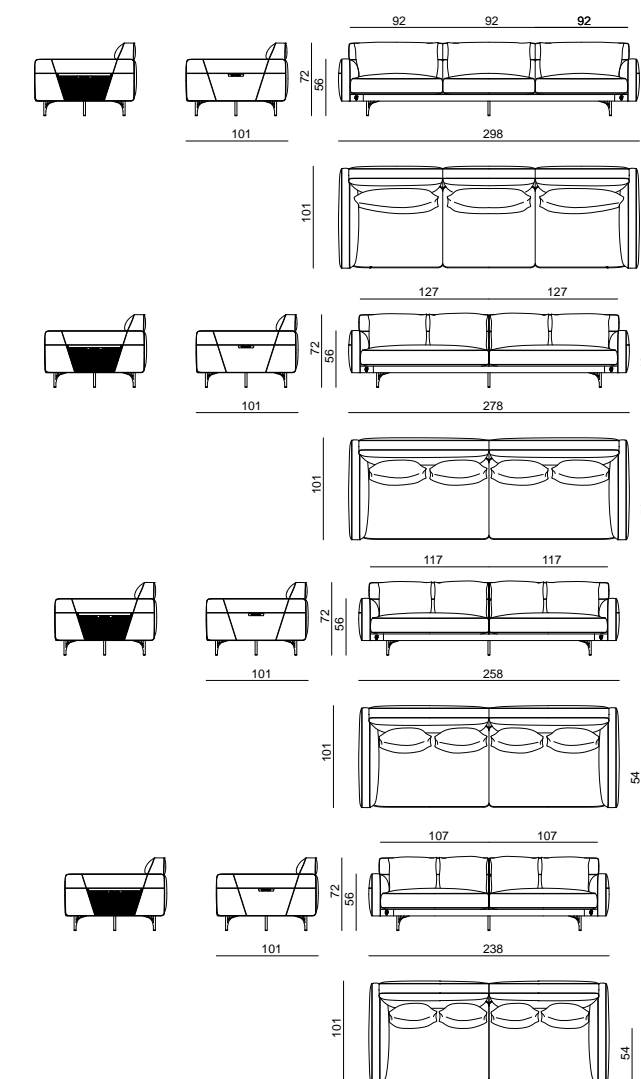



MONTPARNASSE

DIVANO, ELEMENTI COMPONENTI, POLTRONA, CHAISE-LONGUE, DAYBED, POUF
 SOFA, MODULAR ELEMENTS, ARMCHAIR, CHAISE-LONGUE, DAYBED, POUF
 Mauro Lipparini

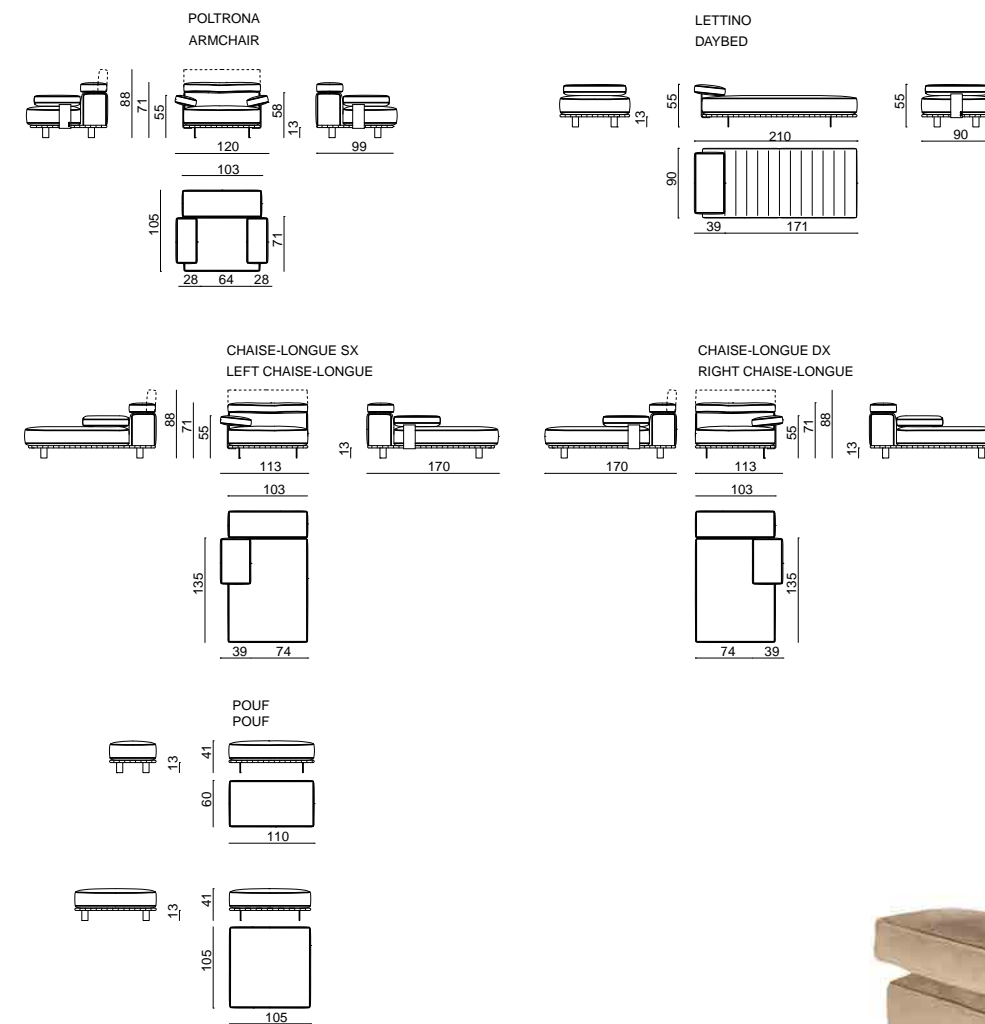
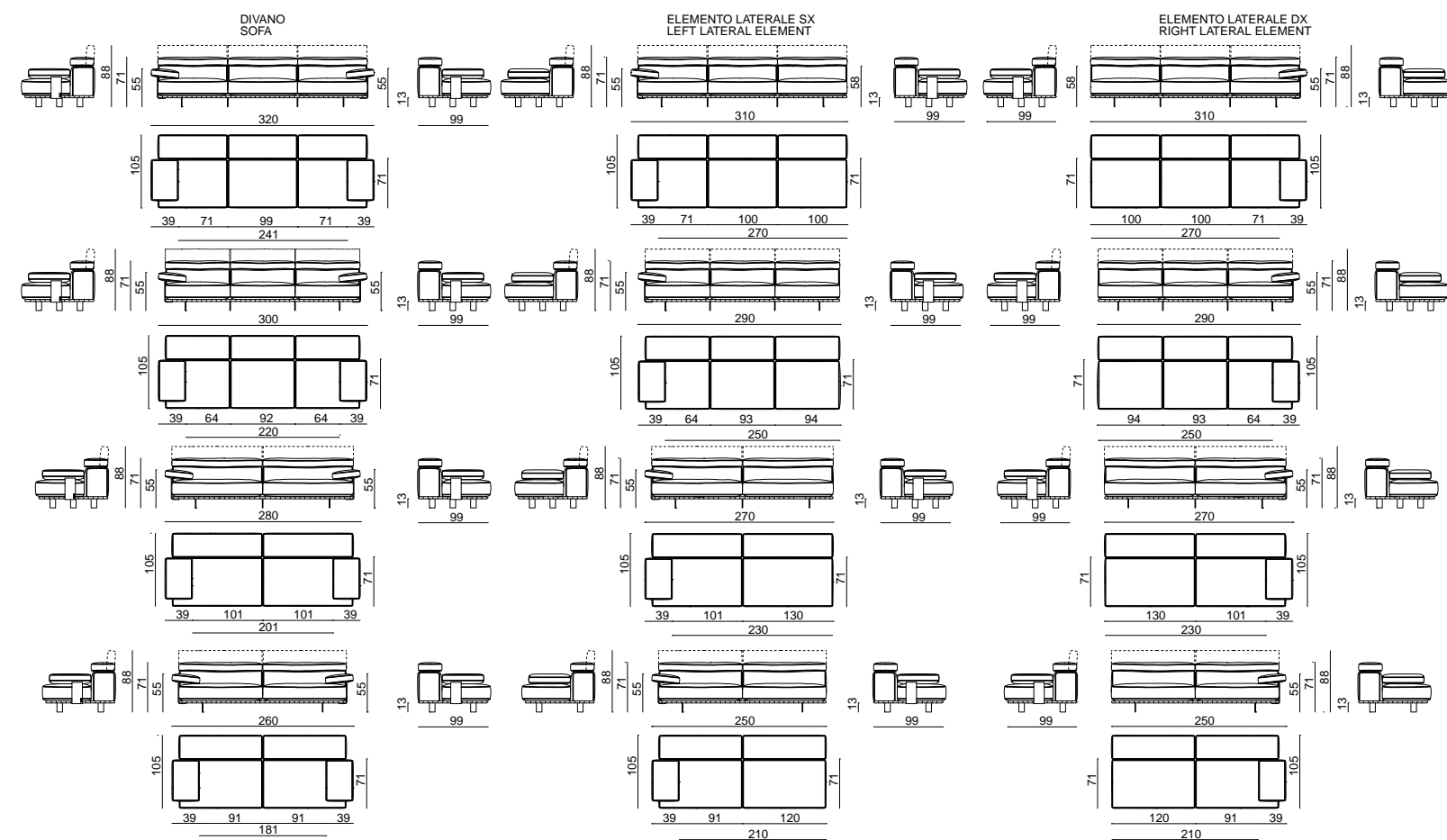

Divano tappezzato in pelle o tessuto, struttura in legno cinghiato per molleggio elastico con piedi in alluminio, a cui è avvitato un telaio metallico a sezione tonda decorato su tutto il perimetro con cinturini in pelle finemente cuciti oppure in tessuto Faber, Gand, Kale, Eco-Skin. Scocca schienale in legno massello e multistrato imbottita in poliuretano a densità differenziate. Poggiatesta imbottito in poliuretano e fibra acrilica con struttura metallica interna reclinabile manualmente. Cuscini di seduta e braccioli in poliuretano, Memory Foam® e piuma. Nella versione in tessuto i filetti e i cinturini sono disponibili nei tessuti Faber, Gand, Kale ed Eko-Skin, oppure in pelle Soft leather, le parti metalliche sono disponibili nella selezione finiture metalliche satinato.

Sofa upholstered in leather or fabric, structure in wood with elastic spring belts, aluminium feet connected by means of crews to a frame in tubular metal with conic section, decorated with belts in leather or fabric Faber, gand, Kale, Eco-Skin. External structure in solid wood and plywood padded in polyurethane foam with different densities. Headrest padded in polyether and acrylic fiber, internal metal structure with adjustable inclination. Seat cushions and armrests in polyurethane foam, Memory Foam® and feather. When upholstered in fabric, piping and belts can be made in fabric Faber, Gand, Kale or Eco-Skin, or in Soft leather, metal parts available in the satinized metal finishing selection.

● click here





MILLER

DIVANO, ELEMENTI COMPONENTI, POLTRONA, CHAISE-LONGUE, POUF
 SOFA, MODULAR ELEMENTS, ARMCHAIR, CHAISE-LONGUE, DAYBED, POUF
 Fabio Bonfà

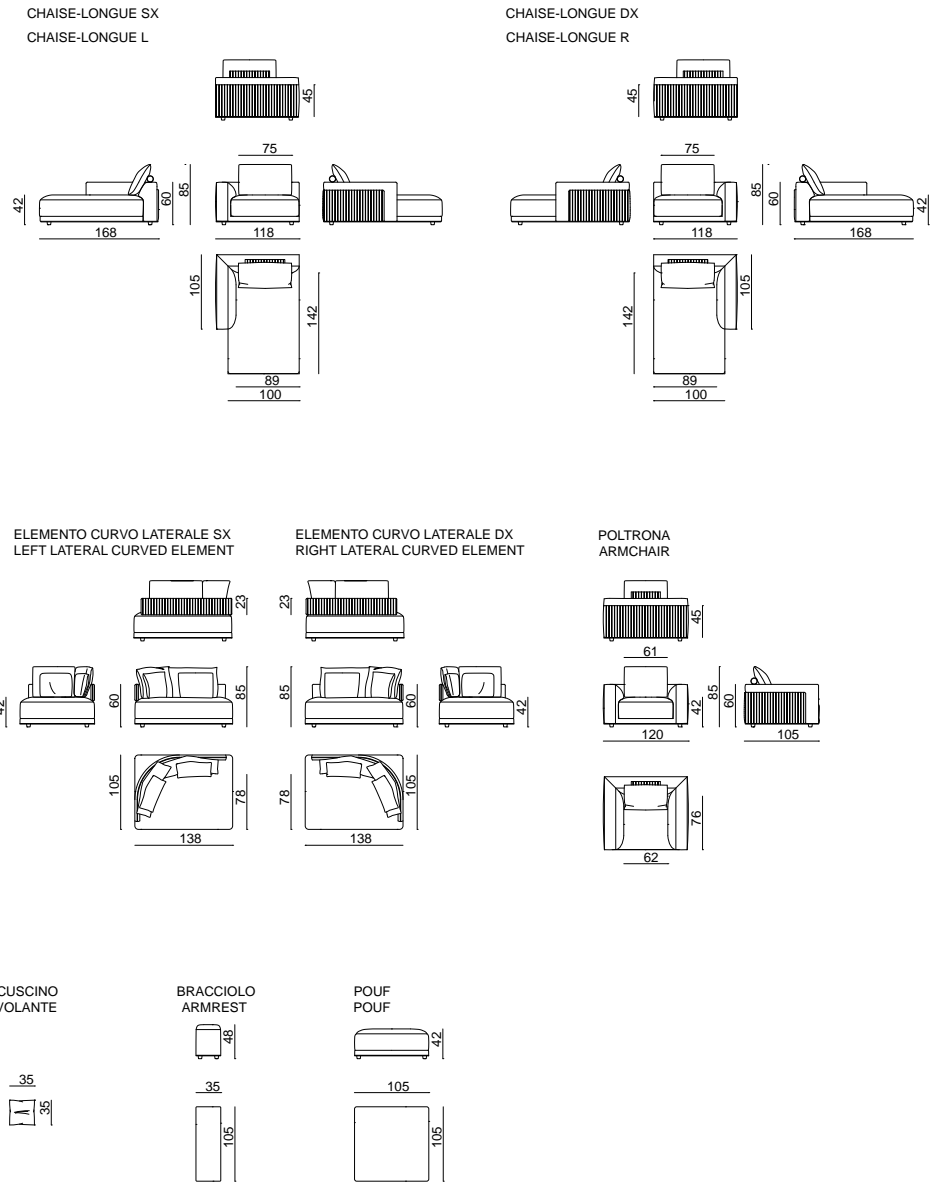
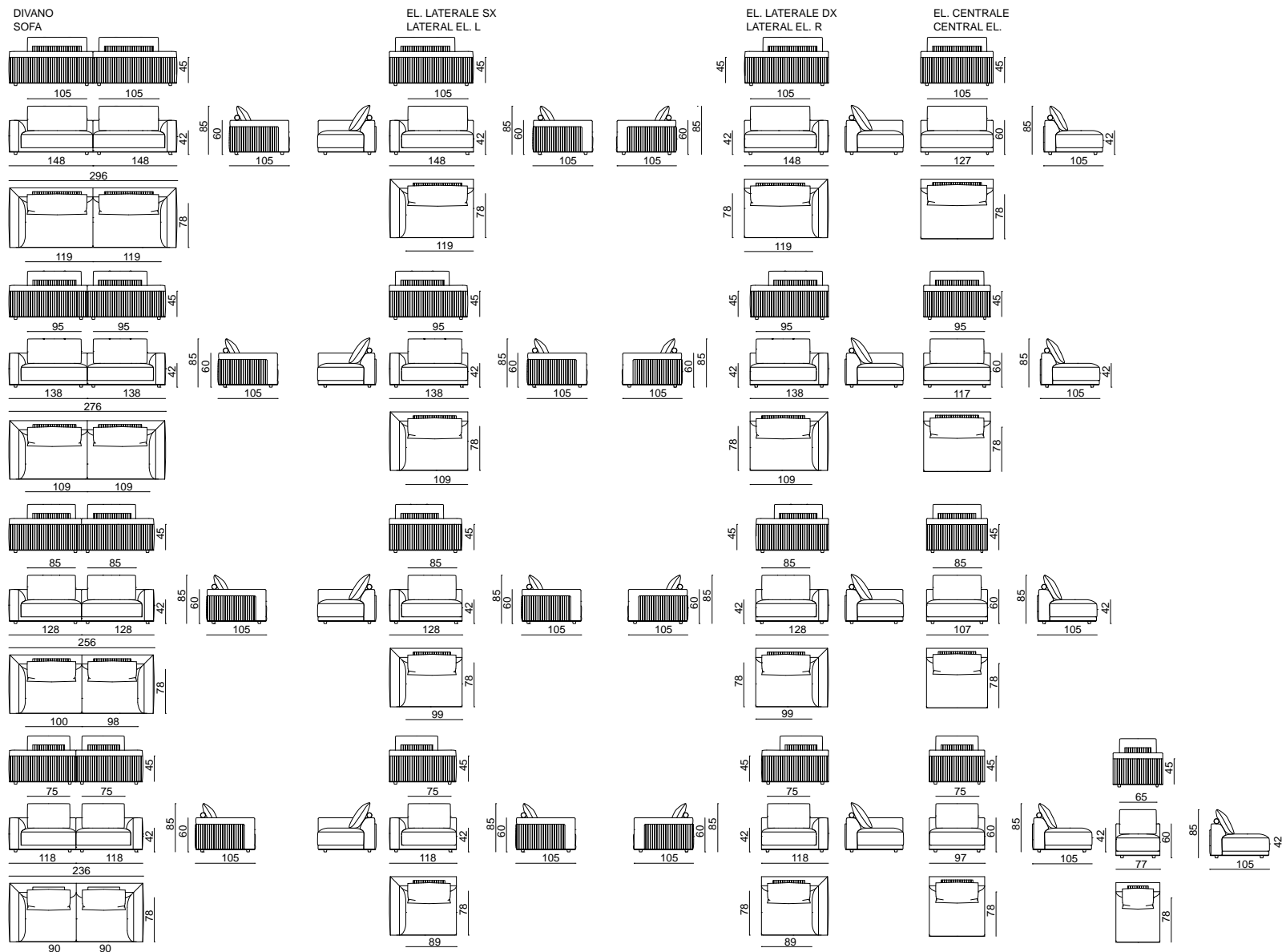

Divano tappezzato in pelle o tessuto, con fusto in legno massello dotato di cinghie elastiche. Cuscini di seduta in poliuretano a densità differenziate, Memory Foam® e piuma. Cuscini di schienale in poliuretano e piuma, muniti di rullo poggiatesta posteriore. Fianchi e schienale sono rivestiti esternamente in tessuto Gand, Faber o Vermeer trapuntato "canneté". Cuscini volanti in piuma. Versione componibile disponibile con elementi centrali, angolari e laterali. Profilo di base in alluminio disponibile nei colori cromo lucido, oro lucido e nichel nero satinato.

Sofa upholstered in leather or fabric, with base consisting of a frame in wood with elastic spring belts. Seat cushion in polyurethane foam with different densities, Memory Foam® and feather. Back cushions in polyurethane and feather, equipped with headrest rolls. Back and sides in curved wood upholstered in Gand, Faber or Vermeer fabric with quilted canneté motif. Loose cushions in feather. Modular version includes central, corner and lateral elements. Base profile in aluminium available with polish chrome, polish gold or satin black nickel finish.

vedi anche/see also MILLER tavolino-small table

● click here



MILLER

DIVANO UNICUM - SOFA UNICUM

Fabio Bonfà

Divano tappezzato in pelle o tessuto, con base composta da un telaio in legno dotato di cinghie elastiche. Cuscino di seduta in poliuretano a densità differenziate, Memory Foam® e piuma. Schienale in legno curvo tappezzato in tessuto Gand, Faber o Vermeer trapuntato "canneté". Cuscini volanti in piuma. Profilo di base in alluminio disponibile nei colori cromo lucido, oro lucido e nichel nero satinato.

Sofa upholstered in leather or fabric, with base consisting of a frame in wood with elastic spring belts. Seat cushion in polyurethane foam with different densities, Memory Foam® and feather. Back in curved wood upholstered in Gand, Faber or Vermeer fabric with quilted canneté motif. Loose cushions in feather. Base profile in aluminium available with polished chrome, polished gold or satin black nickel finish.

● [click here](#)

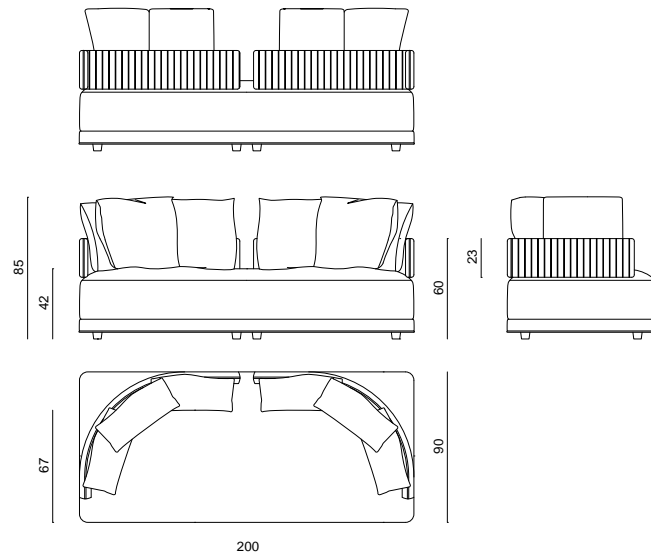

PRESENCE

DIVANO - SOFA

Steve Leung

Divano asimmetrico tappezzato a doppio rivestimento. Fusto in legno in legno massello e multistrati curvati. Sedile molleggiato con cinghiature elastiche, imbottitura in poliuretano a diverse densità, Memory Foam® e piuma. Schienale diviso in due unità curve con diversa lavorazione di trapuntatura. La scocca esterna della parte curva è rivestita in pelle. Piedi in legno laccato lucido colori RAL/NCS.

Asymmetrical sofa with double upholstery. Frame in solid wood and shaped plywood. Seat with elastic belt spring system, padding in polyurethane with different densities, Memory Foam® and feather. Back divided in two shaped parts, decorated with different quilted motifs. Shaped external structure upholstered in leather. Feet in wood lacquered with a shiny RAL/NCS colour.

● [click here](#)

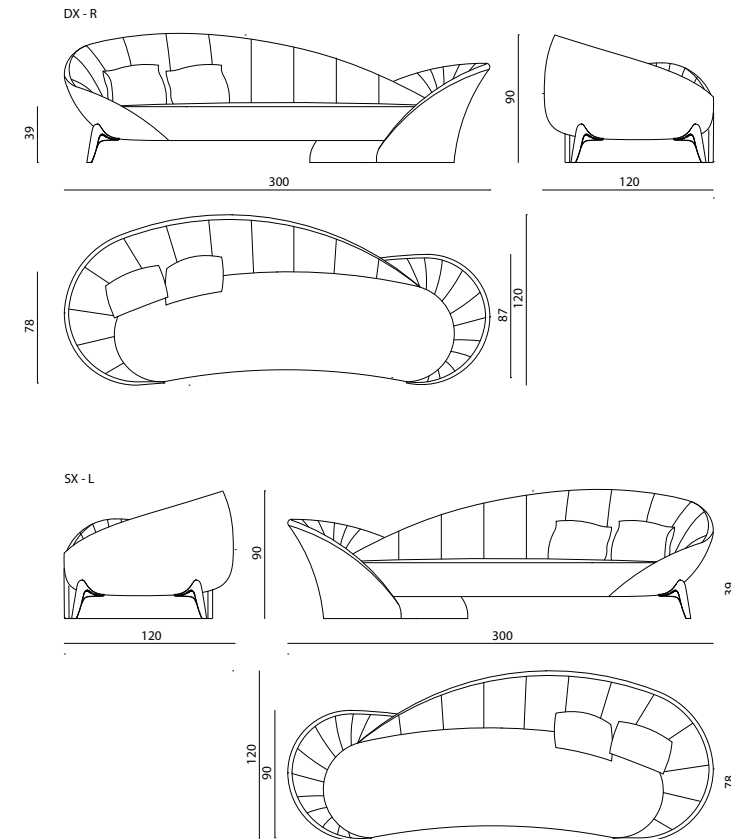



ORLANDO

DIVANO, ELEMENTI COMPONENTI
SOFA MODULAR ELEMENTS
Mauro Lipparini

Divano tappezzato in pelle o tessuto, struttura in legno cinghiato per molleggio elastico con base in legno laccato opaco. Scocca schienale in legno massello e multistrato imbottita in poliuretano a densità differenziate. Poggiatesta imbottito in polietere e fibra acrilica con struttura metallica interna reclinabile manualmente. Cuscini di seduta e braccioli in poliuretano, Memory Foam® e piuma. Profilo inferiore in acciaio. Nella versione in pelle le cuciture sono eseguite a taglio vivo, si raccomanda la scelta di pelli ad alto spessore. Nella versione in tessuto i filetti sono disponibili nei tessuti Faber, Gand, Kale ed Eco-Skin, oppure in pelle Soft leather, le parti metalliche sono disponibili nella selezione finiture metalliche satinare.

Sofa upholstered in leather or fabric, wooden frame with elastic springing and matt lacquered wooden base. Backrest shell made of solid wood and plywood padded with differentiated density polyurethane. Headrest upholstered in polyether and acrylic fibre with manually reclining internal metal frame. Seat and armrest cushions in polyurethane, Memory Foam® and feather. Steel lower profile. In the leather version the stitching is raw cut; thick leather is recommended. In the fabric version the pipings are available in Faber, Gand, Kale and Eco-Skin fabrics, or in Soft leather; the metal parts are available in the satin finish metal selection.

● click here

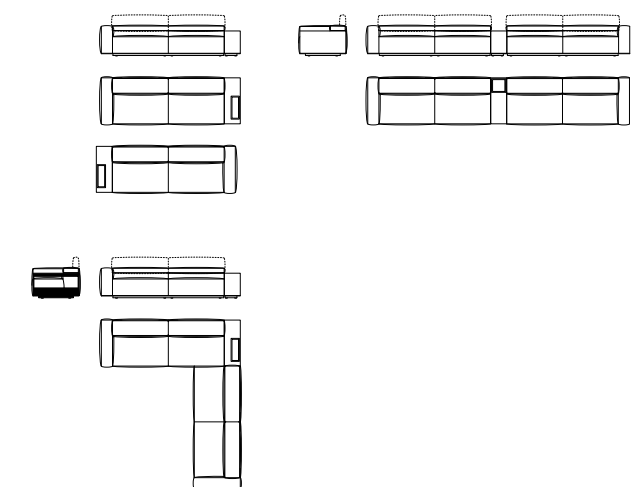
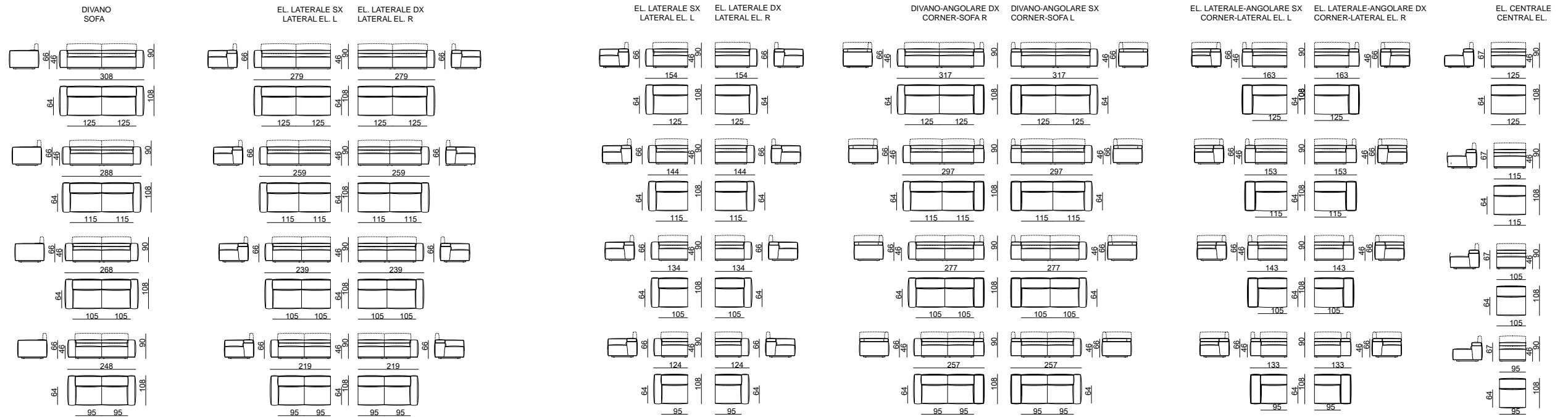



RHAPSODY

DIVANO, POLTRONA - SOFA, ARMCHAIR
Fabio Bonfà

Divano in pelle o tessuto, fusto in multistrati e massello di legno con telaio di seduta molleggiato con cinghie elastiche e fusto di braccioli e schienale curvo. Imbottitura della scocca e cuscini di seduta in poliuretano a densità differenziate e falda. Cuscini di schienale e reggireni in piuma. Elementi di sostegno tubolari per gli schienali in poliuretano fissati al retro dei cuscini schienale. Il retro schienale è disponibile in pelle o tessuto a contrasto di colore con trapuntatura cannettata o in pelle stampata con motivo a intreccio, filetti a contrasto in pelle. Logo Visionnaire in ottone cromato sul bracciolo sinistro. Piedi e profilo inferiore in alluminio. Le parti metalliche sono disponibili nelle finiture metalliche oro e cromo. Nelle misure più grandi il divano è fornito smontato in due metà, con 4 piedi ciascuna. Cuscini reggireni disponibili in contrasto.

Sofa in leather or fabric, structure in plywood and solid wood, seat frame webbed with elastic belts and curved armrest and backrest structure. Padding of external structure and seat cushions in polyurethane with different densities and acrylic fiber. Back cushions and small cushions in feather. Backrest tubular supports in polyurethane foam, fixed to the rear of the back cushions. Rearback available with leather or fabric contrasting upholstery with cannetté quilting or in leather with printed interwoven pattern. Piping in contrasting leather. Visionnaire logo in chromed brass on the left armrest. Feet and lower profiles in aluminium. Metal parts available with gold or chrome lacquered finish. For larger sizes, the sofa is packed disassembled in 2 parts, with 4 feet each. Small back cushions available in contrasting colours.

● click here

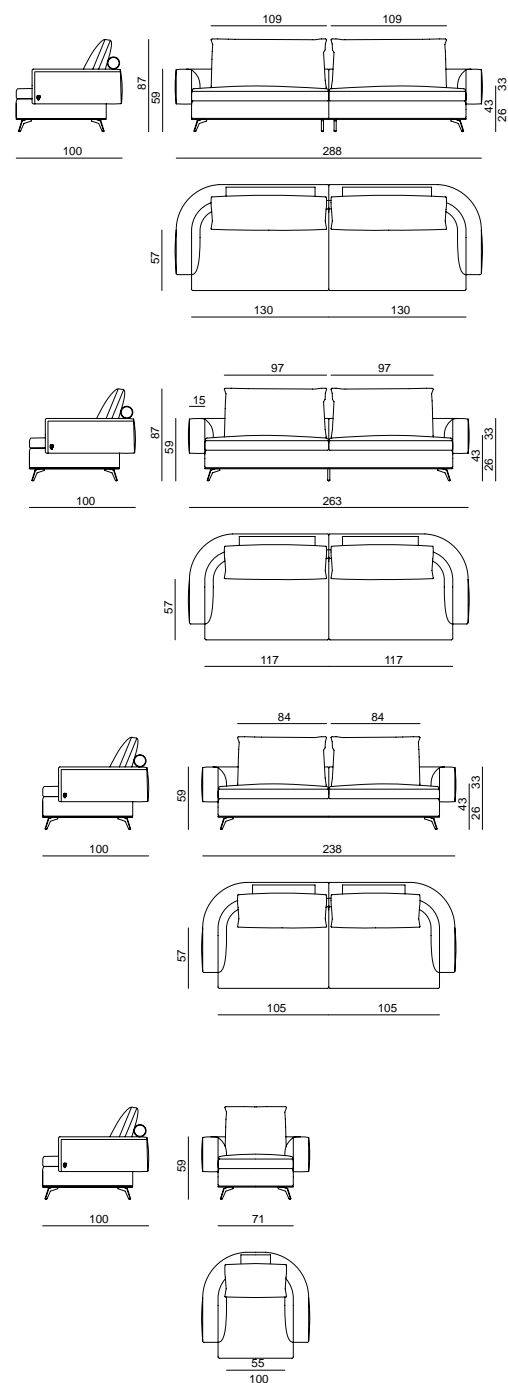

VANITY FAIR

DIVANO - SOFA
Giuseppe Viganò

Struttura portante in abete massiccio e multistrati di pioppo imbottita in poliuretano espanso, molleggio seduta a cinghie elastiche. Rivestimento della scocca in pelle o tessuto e cover double face, con leggera trapuntatura in piuma d'oca e sistema di chiusura con cerniere nascoste. Basamento in alluminio sagomato con finitura spazzolata. La pelliccia è disponibile in finitura naturale su base grigia o marrone, o tinta tortora. Le parti metalliche sono disponibili nella selezione finiture metalliche satinare.

Main structure in solid pinewood and poplar plywood padded with extended polyurethane. Spring seat system with elastic belts. Body upholstery in leather or fabric. Reversible cover, lightly quilted with goose down and closed by a hidden zip. Plinth in moulded brushed aluminium. The fur coating is available in natural finishing on a gray or brown base or in dove-gray colour. Metal parts available in the satinized metal finishing selection.

POLTRONA - ARMCHAIR

Struttura portante sagomata in ferro smaltato e maglia metallica, imbottita in poliuretano espanso. Molleggio seduta a cinghie elastiche. Rivestimento della scocca in pelle o tessuto e cover double face, con leggera trapuntatura in piuma d'oca e sistema di chiusura con alamari nascosti. Gambe in ferro conifcato smaltato ed elementi di finitura in alluminio tornito e cromato. Loghi Visionnaire in ottone cromato sulle gambe posteriori. La pelliccia è disponibile in finitura naturale su base grigia o marrone, o tinta tortora. Le parti metalliche sono disponibili nella selezione finiture metalliche satinare.

Main structure in moulded enamelled iron and metallic mail padded in expanded plyurethene. Seat spring system with elastic belts. Body upholstery in leather or fabric. Reversible cover, lightly quilted with goose down and closed by hidden frog. Legs in enamelled iron with conic shape. Finishing elements in turned and chromed aluminium. Visionnaire logos in chromed brass over the back legs. The fur coating is available in natural finishing on a gray or brown base or in dove-gray colour. Metal parts available in the satinized metal finishing selection.

vedi anche/see also VANITY FAIR chaise-longue, VANITY FAIR pouf-pouffe

● click here

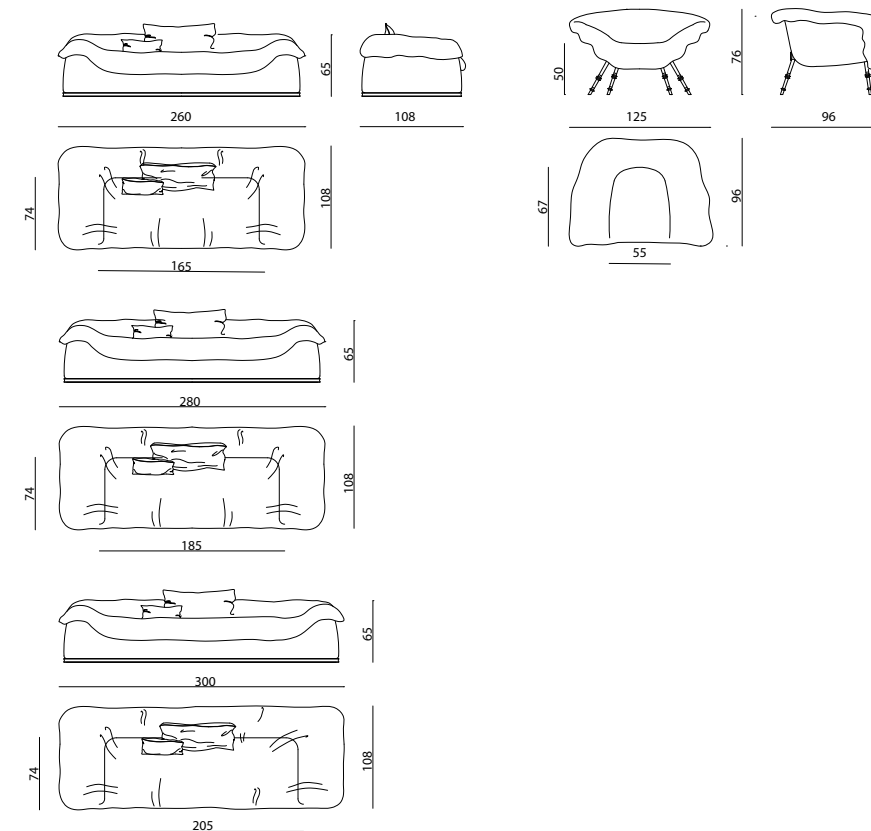



XAVIER MASTER XAVIER BOARD

DIVANO, ELEMENTI componibili - SOFA, MODULAR ELEMENTS
Mauro Lipparini

XAVIER MASTER

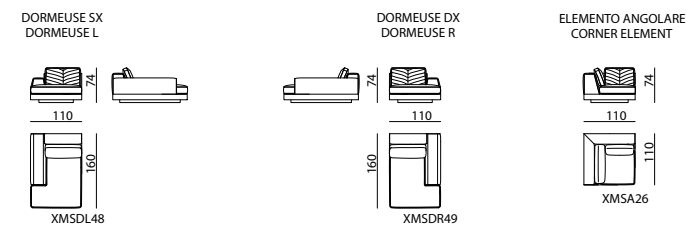
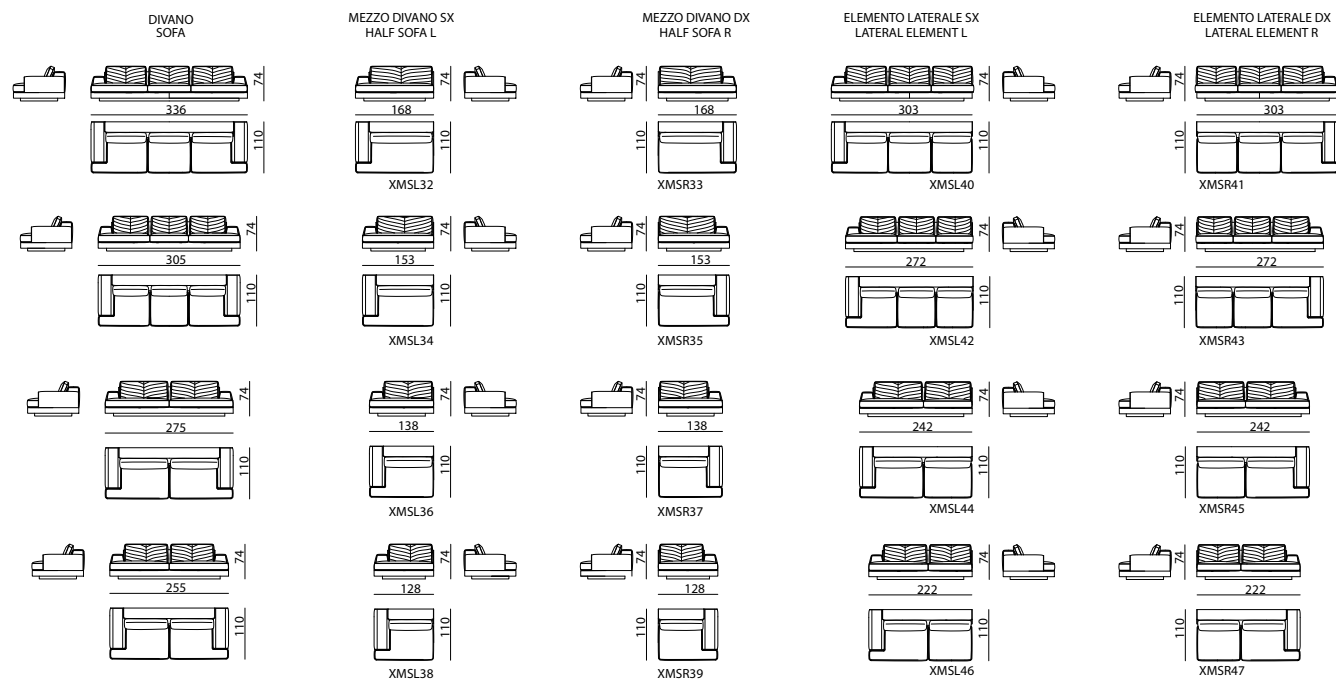

XAVIER BOARD
XAVIER BOARD - sectional

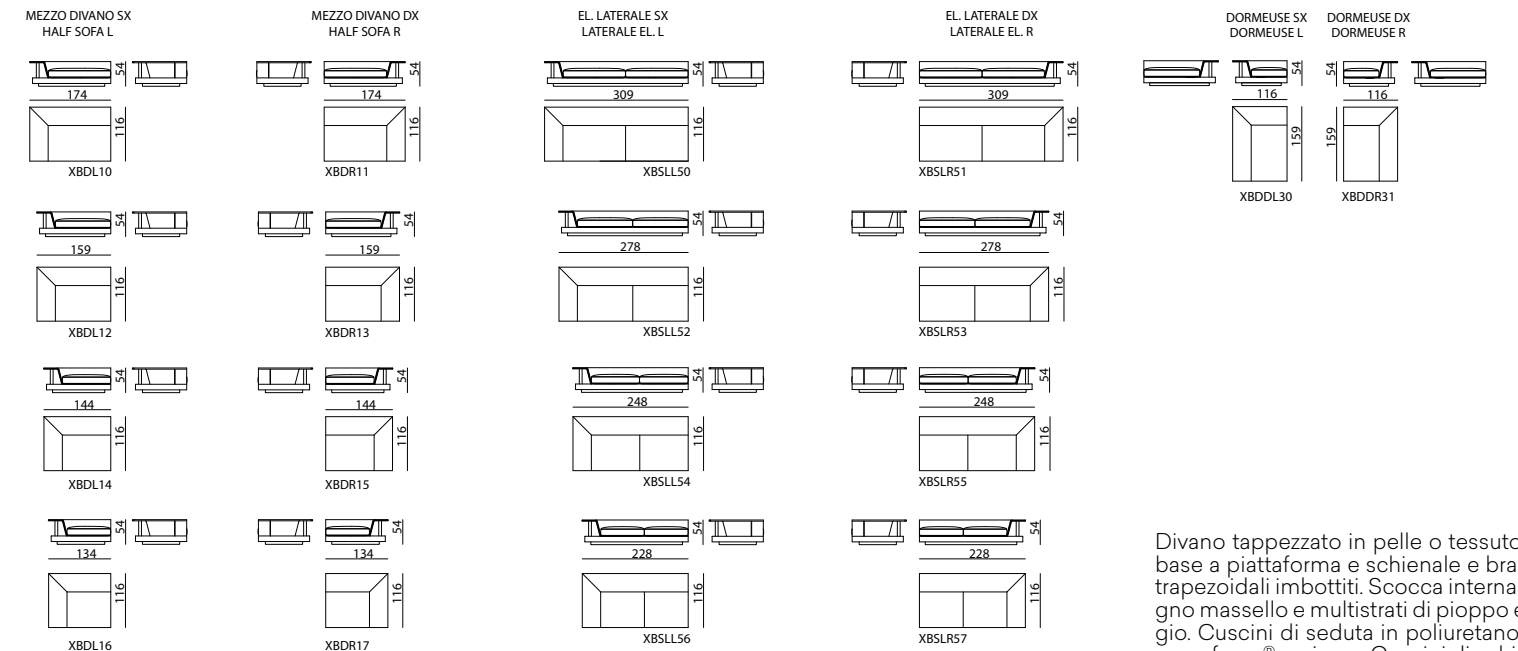

XAVIER BOARD
XAVIER BOARD - sectional with extension

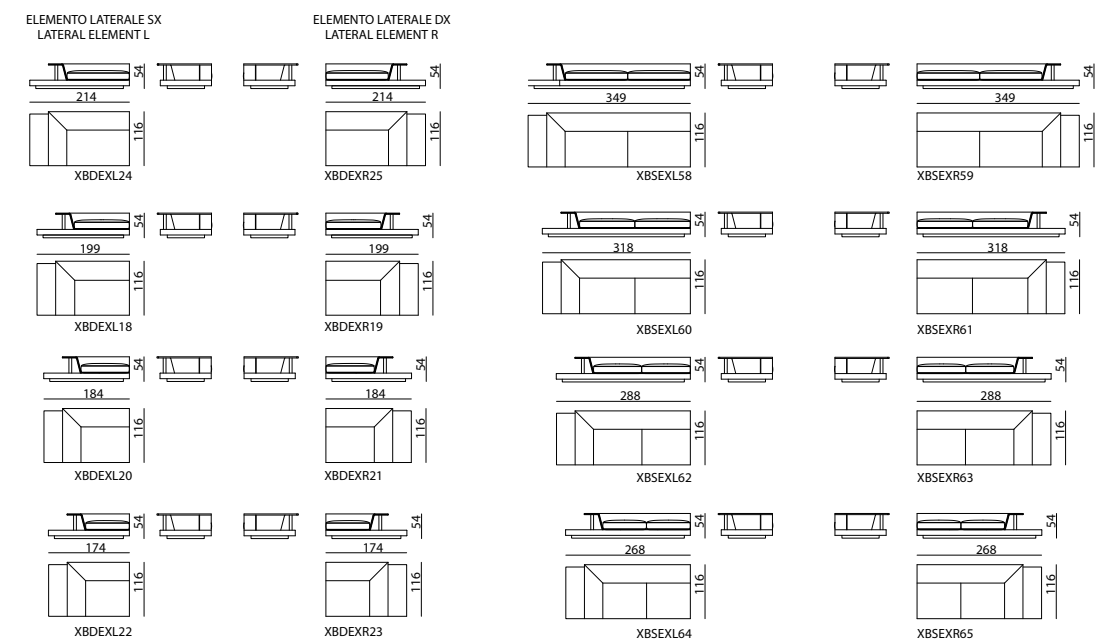

Divano tappezzato in pelle o tessuto, con base a piattaforma e schienale e braccioli trapezoidali imbottiti. Scocca interna in legno massello e multistrati di pino e faggio. Cuscini di seduta in poliuretano, memory foam® e piuma. Cuscini di schienale con lavorazione "chevron" in poliuretano e piuma. Disponibile anche con bracciolo e schienale in versione "board" in legno rivestito in pelle, tessuto o pelle intrecciata; elementi strutturali e decorativi in ottone massiccio satinato con placche incise con logo Visionnaire. Cuscini schienale in diverse misure in poliuretano e piuma. Gli elementi laterali "board" sono disponibili anche con piattaforma estesa "extension" sotto il bracciolo di +40 cm.

Upholstered leather or fabric sofa, with platform base and backrest and trapezoidal upholstered armrests. Inner shell in solid wood and poplar and beech plywood. Seat cushions in polyurethane, memory foam® and feather. Back cushions with "chevron" processing in polyurethane and feather. Also available with armrest and backrest in the "board" version in wood upholstered in leather, fabric or woven leather; structural and decorative elements in solid satin brass with engraved plaques with Visionnaire logo. Backrest cushions in different sizes in polyurethane and feather. The side "board" elements are also available with optional "extension" platform under the armrest of +40 cm.

click here



AVALON, AVALON EASY

DIVANO, POLTRONA - SOFA, ARMCHAIR
Alessandro La Spada - Samuele Mazza

Struttura portante in legno massello e compensato, di pioppo. Molleggio seduta a nastri elastici. Imbottitura in resine espanse a quote differenziate e falda di fibra acrilica. Cuscini di seduta in Rhombo-Fè (piuma d'oca mischiata a chips di poliuretano) con fodera in tela di cotone 100%. Cuscini volanti in Roll-Piuma con fodera in tela cotone. Gambe in acciaio inox lucido, taglio laser. Rivestimento della struttura, non sfoderabile. Cuscini seduta e cuscini volanti, rivestimento sfoderabile. Gambe in fusione di alluminio con finitura a bassorilievo trama cocodrillo, lucidata a specchio.

Main frame in solid wood and poplar plywood. Sprung system made of elastic belts. Padding consists of expanded resins in different densities and a layer of acrylic fibre. Seat cushions in Rhombo-Fè (feathers and polyurethane "chips" mixture) covered with a 100% cotton lining. Loose cushions in Roll-feathers with cotton cover. Legs in polished laser cut Inox steel. The cover of the structure is not removable. Covers for seat and loose cushions are removable. Polished legs in aluminium fusion with a low-relief finishing in crocodile design.

● click here

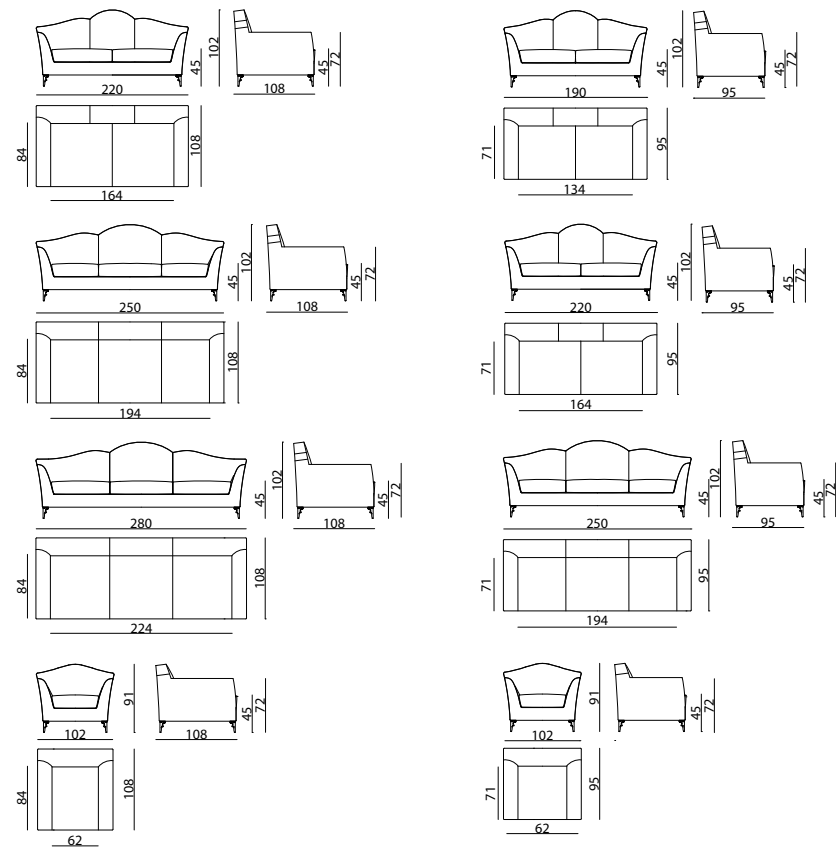

BERRY TRAPUNTATO BERRY CAPITONNÉ

DIVANO, POLTRONA - SOFA, ARMCHAIR
Giuseppe Viganò

Scocca esterna in multistrati di pioppo curvato e sagomato, parzialmente impiallacciata (radica-ebano-platano) o laccata (colori RAL) in combinazione a rivestimento in pelle o tessuto con inserto acciaio inox lucido. Basamento in MDF laccato lucido (colori RAL) completato da angolari in acciaio inox lucido, molleggio a cinghie elastiche. Cuscini di seduta in poliuretano a doppia densità, Memory Foam® e piuma d'oca, schienale e fianchi con lavorazione capitonné o trapuntati. Tappezzeria in pelle o tessuto, profili e angolari disponibili anche con finitura laccata oro, bronzo o nickel nero.

External structure in plywood poplar curved shaped, partially veneered (briar - ebony - plane tree) or lacquered (RAL colours), in combination with external cover in leather or fabric with polished stainless steel inserts. MDF polished lacquered base (RAL colours) with polished stainless steel angles, sprung system with elastic bands. Seat pillows in polyurethane with double density, Memory Foam® and goose feathers, backrest and internal sides with capitonné finishing. Leather or fabric upholstery, angles and profiles also available lacquered gold, bronze or black nickel.

vedi anche/see also BERRY vetrinetta-glass column cabinet

● click here

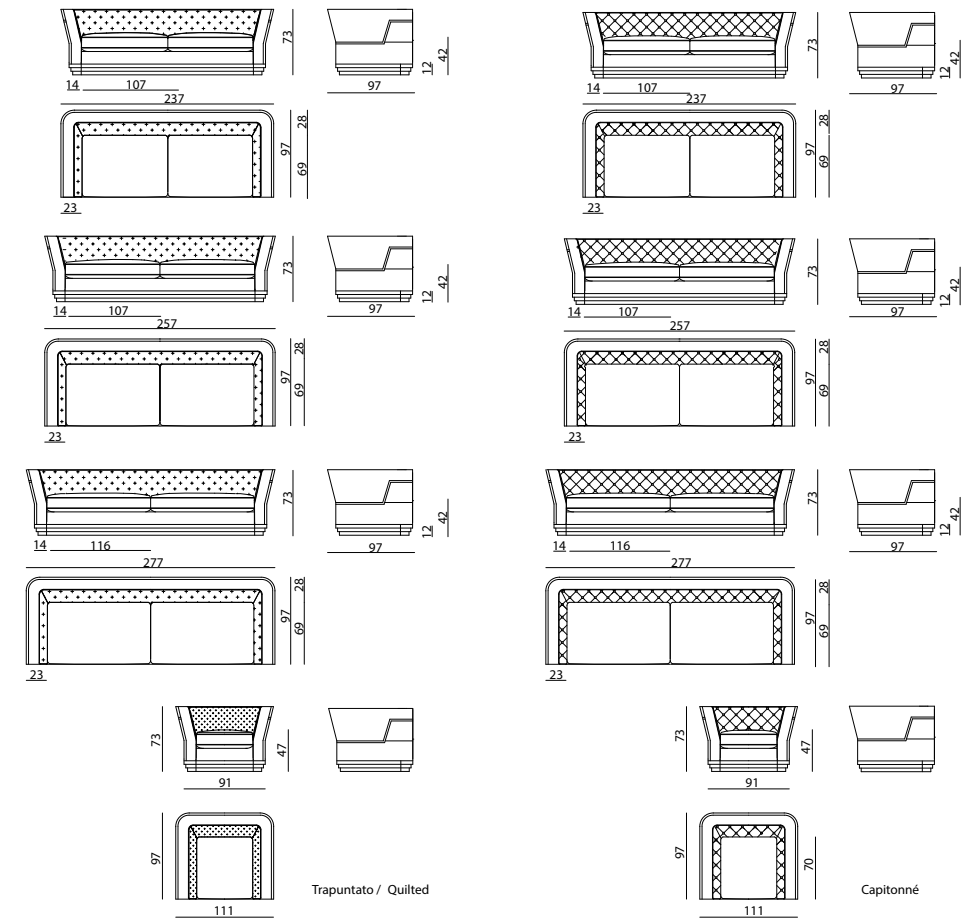



CHESTER DONEY

DIVANO, POLTRONA - SOFA, ARMCHAIR
La Conca

Divano con rivestimento fisso in pelle o tessuto, struttura in legno massello e multistrato, molleggio di seduta a cinghie elastiche. Imbottitura dei sedili in poliuretano a densità differenziate, Memory Foam® e piuma, schienale con lavorazione capitonné. Fettucce di finitura in pelle e logo in ottone. Zoccolo sagomato in alluminio satinato. Le parti in metallo sono disponibili nella selezione finiture metalliche satiniate.

Sofa with non-removable upholstery in leather or fabric; structure in solid wood and plywood, seat with elastic belt spring system. Seat padded in polyurethane with different densities, Memory Foam® and feather; capitonné internal backrest. Decorative leather bands and brass logo. Shaped plinth in satin aluminium. Metal components can be finished with any lacquer of the satinized metal lacquer finish selection.

● [click here](#)

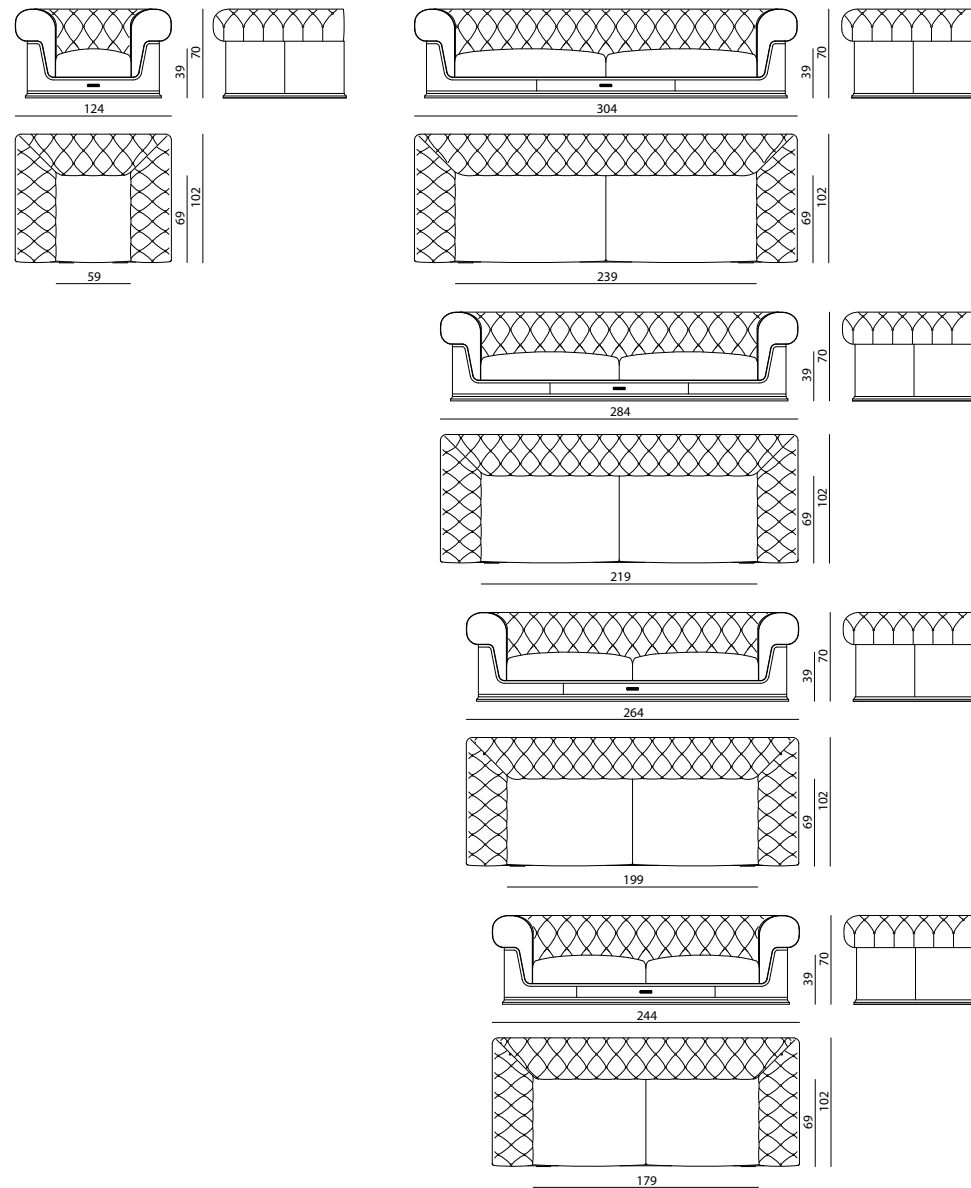

CHESTER LAURENCE

DIVANO, POLTRONA - SOFA, ARMCHAIR
Roberto Tapinassi - Maurizio Manzoni

Divano con rivestimento in pelle o tessuto. Schienale con lavorazione capitonné. Struttura in abete massello e multistrato di pioppo da 25 mm di spessore. Molleggio di seduta a cinghie elastiche. Imbottitura in poliuretano espanso a densità differenziate ricoperto da lastra in Memory Foam® e piuma d'oca. Fascia di finitura in cuoio stampato a rilievo con trama "ovali" e fibbie decorative in ottone anticato. Zoccolo in alluminio sagomato. Rivestimento non sfoderabile, le parti metalliche sono disponibili nella selezione finiture metalliche satiniate.

Sofa upholstered in leather or fabric. Backrest in capitonné finishing. Structure in solid fir and poplar plywood th. 25 mm. Seat sprung system made of elastic belts. Padding in polyurethane with different densities covered by a Memory Foam® layer and goose down. Perimeter stripes in leather with embossed ovals and decorative buckles in antique brass. Plinth in moulded aluminium. Cover not removable, metal parts available in the satinized metal finishing selection.

● [click here](#)

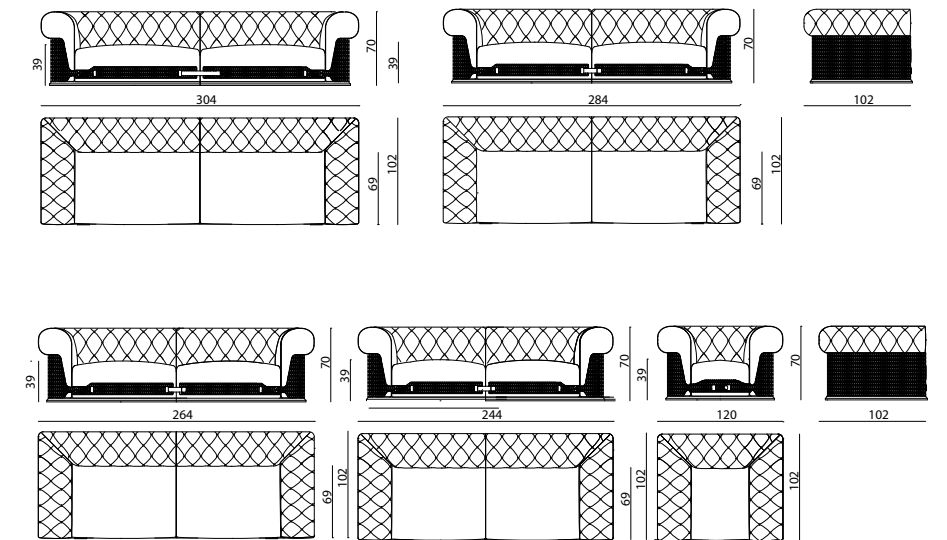



DIPLOMATE

DIVANO, POLTRONA - SOFA, ARMCHAIR
Samuele Mazza

Struttura portante in pannelli multistrati di pioppo e listelli di abete con tamponature in faesite. Molleggio seduta a cinghie elastiche intrecciate. Imbottitura scocca in poliuretano ad alta elasticità. Cuscini seduta in poliuretano e rinfascio in piuma incamerata. Piedi a forma circolare in legno ricoperto di lamina di ferro cromato. Scudo in acciaio inox lucido, con incisione stemma araldico Visionnaire, applicato sul fronte braccioli. Rivestimento della scocca in pelle o tessuto non sfoderabile. Rivestimento cuscini seduta sfoderabili. La tappezzeria può essere confezionata, a richiesta con filetti scoubidou in pelle. Disponibile anche nella versione con ciotola portaoggetti in marmo Frappuccino, con incisione stemma araldico Visionnaire.

Main structure in poplar plywood panels and fir strips with faesite fillers. Seat sprung system made of twisted elastic belts. Frame padding in high elasticity polyurethane. Seat cushions in polyurethane and cover in feather. Circular feet in wood covered in chromed iron. Shield in polished stainless steel, with Visionnaire logo engraving, fixed on the front of the arms. Structure cover in leather or fabric not removable. Seat covers removable. The upholstery can also be done with scoubidou pipings in leather (upon request). Version also available with bowl in Frappuccino marble, with Visionnaire logo engraving.

vedi anche/see also DIPLOMATE letto-bed

● click here

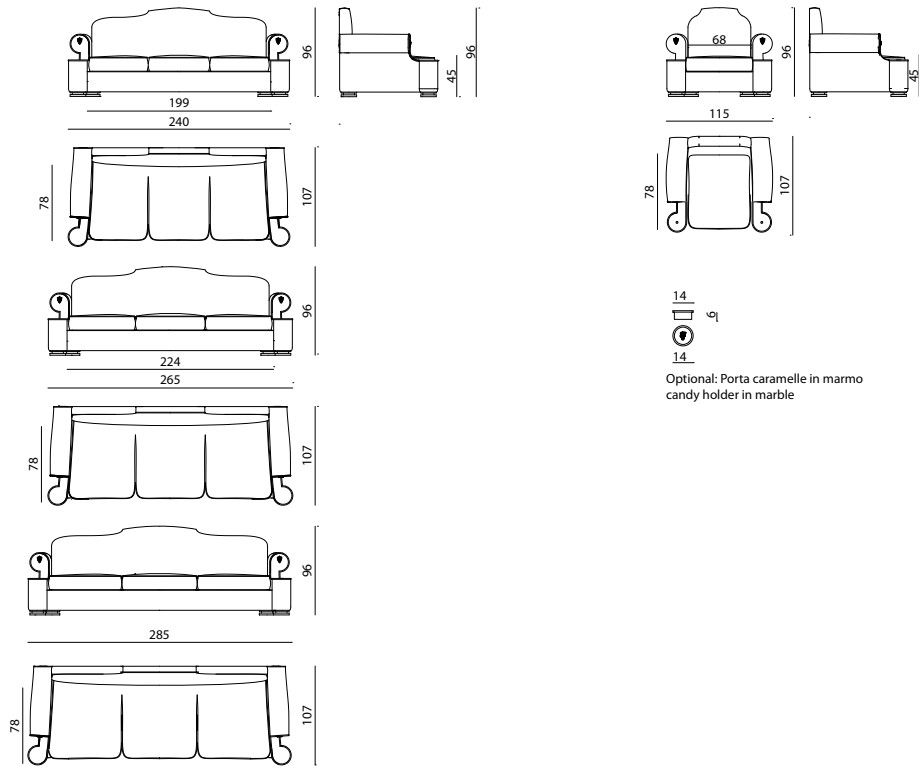

ENEA

DIVANO, POLTRONA - SOFA, ARMCHAIR
Samuele Mazza

Telaio portante in multistrati di betulla e listellare di abete, con tamponature in faesite. Molleggio seduta a cinghie elastiche. Imbottitura scocca in lastre di poliuretano. Cuscini seduta in poliuretano a quote differenziate con lastra in schiuma poliuretana Mind Foam® e ricopertura in piuma 100% camerata. Cuscini schienale misto fiocco 70% e piuma 30%. Trapuntatura schienale e braccioli con falda acrilica a forte spessore. Zoccolo di base in legno rivestito con lamina di acciaio inox lucido oppure rivestito in pelle o tessuto. I braccioli possono essere, su richiesta, decorati con anelli tortili su borchia, in fusione di ottone. Le parti metalliche sono disponibili nella selezione finiture metalliche.

Main structure in birch plywood and fir wood stripes, with fillings in masonite wood. Seat sprung system with elastic belts. Frame padding in polyurethane layers. Seat cushions in polyurethane in different densities with Mind Foam® polyurethane foam layer and covering with 100% feather. Back cushions 70% staple and 30% feather. Back quilting and arms in acrylic layer with high thickness. Wooden base covered with shiny stainless steel laminate or upholstered in leather or fabric. Upon request, the arms can be decorated with twisted rings on stud, made in brass fusion. Metal parts can be lacquered in any colour of the metal finish selection.

● click here

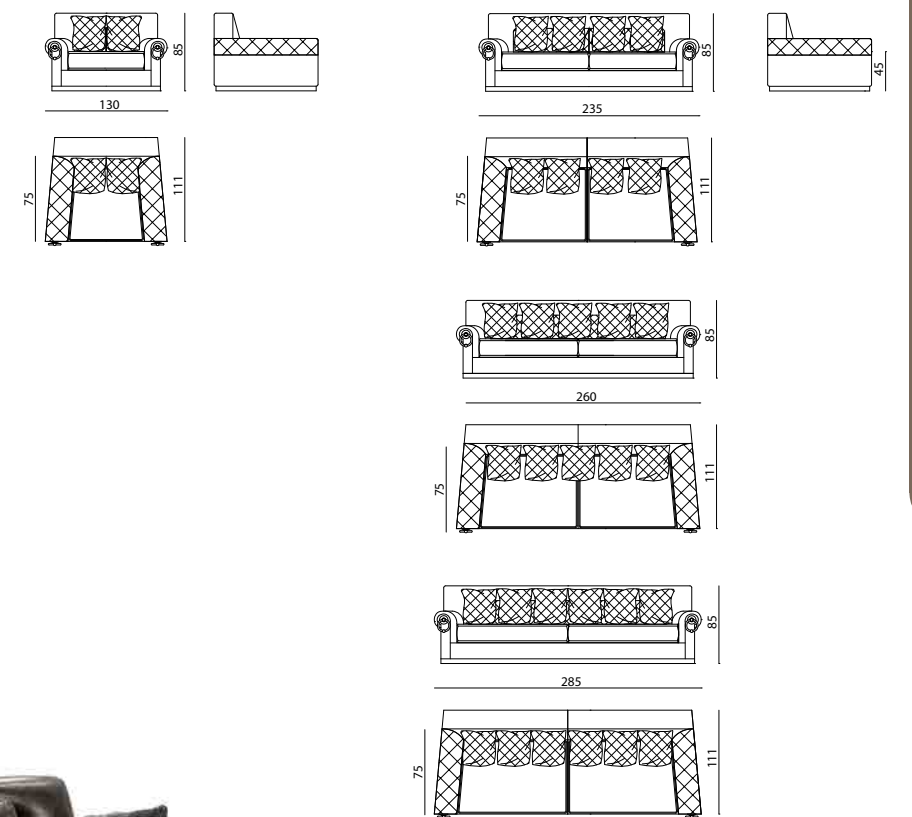



GINEVRA

DIVANO, POLTRONA, POUF - SOFA, ARMCHAIR, POUFFE

Alessandro La Spada - Samuele Mazza

Struttura portante in multistrato di pino e legno massello d'abete. Molleggio seduta e schienale a cinghie elastiche. Imbottitura in resine espanse a quote differenziate. Foderatura in vellutino acrilico accoppiato a falda acrilica. Cuscini di seduta in Rombo Fe® (piuma d'oca mischiata a chips di poliuretano), fodera in cotone. Cuscini volanti in Mollapiuma (piuma d'anatra mischiata a falda di fibra acrilica), fodera in cotone. Gambe in acciaio. Rivestimento sfoderabile. Le parti metalliche sono disponibili nella selezione finiture metalliche.

Main structure in pinewood multiply and fir solid wood. Sprung system for seat and back sides made of elastic belts. Padding with expanded resins in different densities. Acrylic lining coupled with an acrylic fibre layer. Seat cushions in Rombo Fe® (feathers and polyurethane "chips" mixture), covered with cotton lining. Loose cushions in Mollapiuma (duck feathers coupled with acrylic fibre layer), covered with cotton lining. Legs in stainless steel. Cover removable. Metal parts can be lacquered in any colour of the metal finish selection.

● click here

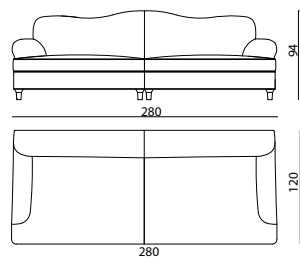
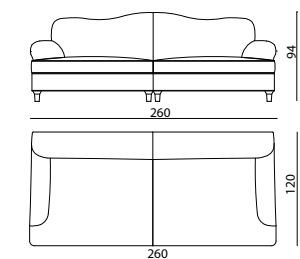
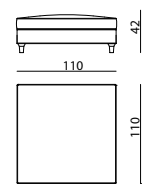
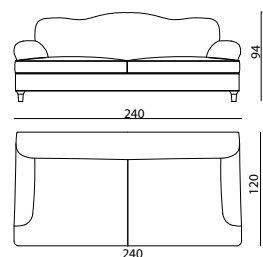
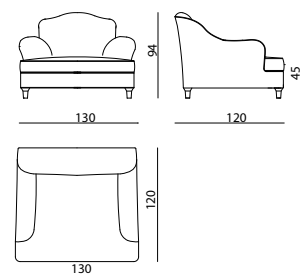
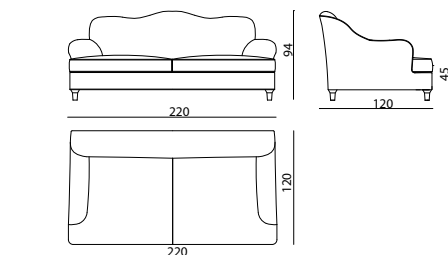

GINEVRA MODULAR

DIVANO, ELEMENTI COMPONENTI - SOFA, MODULAR ELEMENTS

Alessandro La Spada - Samuele Mazza

Struttura portante in multistrato di pino e legno massello d'abete. Molleggio seduta e schienale a cinghie elastiche. Imbottitura in resine espanse a quote differenziate. Fodera in vellutino acrilico accoppiato a falda acrilica. Cuscini di seduta in Rombo Fe® (piuma d'oca mischiata a chips di poliuretano), fodera in cotone. Cuscini volanti in Mollapiuma (piuma d'anatra mischiata a falda di fibra acrilica), fodera in cotone. Gambe in acciaio. Rivestimento sfoderabile. Le parti metalliche sono disponibili nella selezione finiture metalliche.

Main frame in pinewood plywood and fir solid wood. Sprung system for seat and back sides made of elastic belts. Padding with expanded resins in different densities. Acrylic lining coupled with an acrylic fibre layer. Seat cushions in Rombo Fe® (feathers and polyurethane "chips" mixture), cotton cover. Loose cushions in Mollapiuma (duck feathers coupled with acrylic fibre layer), covered with cotton lining. Legs in stainless steel. Cover removable. Metal parts can be lacquered in any colour of the metal finish selection.

● click here

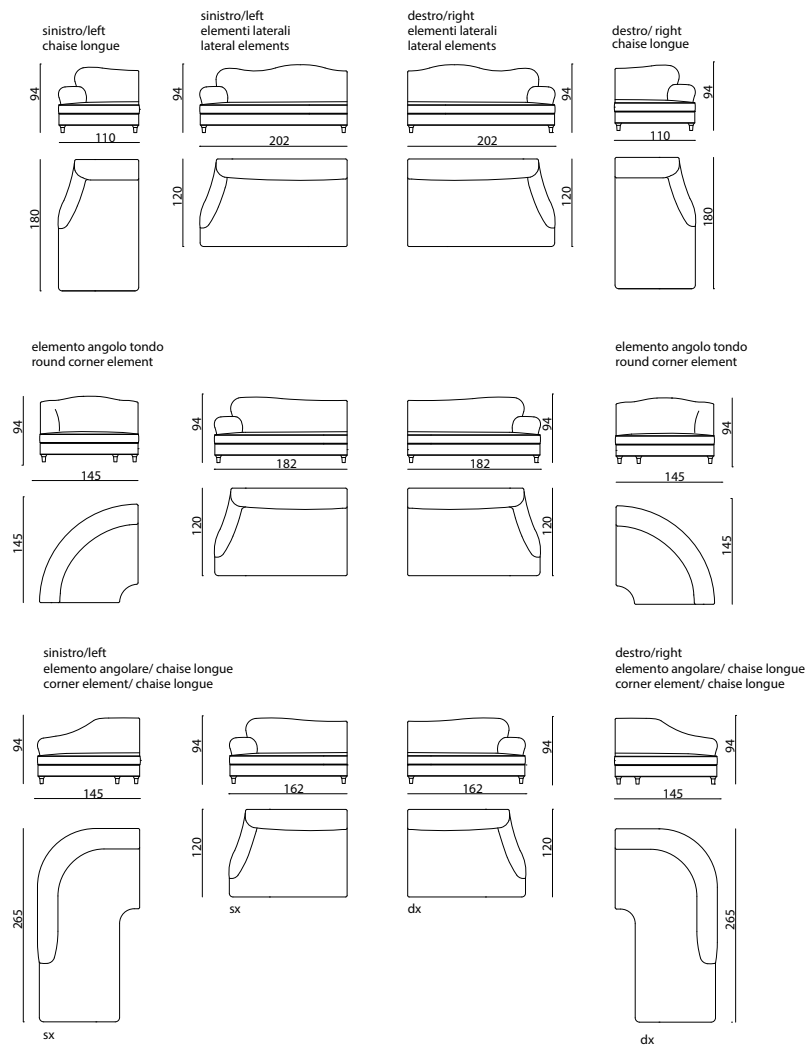



GINEVRA SHAPED

DIVANO SAGOMATO - SHAPED SOFA

Alessandro la Spada - Samuele Mazza

Struttura portante in multistrato di pino e legno massello d'abete. Molleggio seduta e schienale a cinghie elastiche. Imbottitura in resine espanse a quote differenziate. Fodera in vellutino acrilico accoppiato a falda acrilica. Cuscini di seduta in Rombo Fe® (piuma d'oca mischiata a chips di poliuretano), fodera in cotone. Cuscini volanti in Mollapiuma (piuma d'anatra mischiata a falda di fibra acrilica), fodera in cotone. Gambe in acciaio. Rivestimento sfoderabile. Le parti metalliche sono disponibili nella selezione finiture metalliche.

Main frame in pinewood plywood and fir solid wood. Sprung system for seat and back sides made of elastic belts. Padding with expanded resins in different densities. Acrylic lining coupled with an acrylic fibre layer. Seat cushions in Rombo Fe® (feathers and polyurethane "chips" mixture), cotton cover. Loose cushions in Mollapiuma (duck feathers coupled with acrylic fibre layer), covered with cottonlining. Legs in stainless steel. Cover removable. Metal parts can be lacquered in any colour of the metal finish selection.

● click here

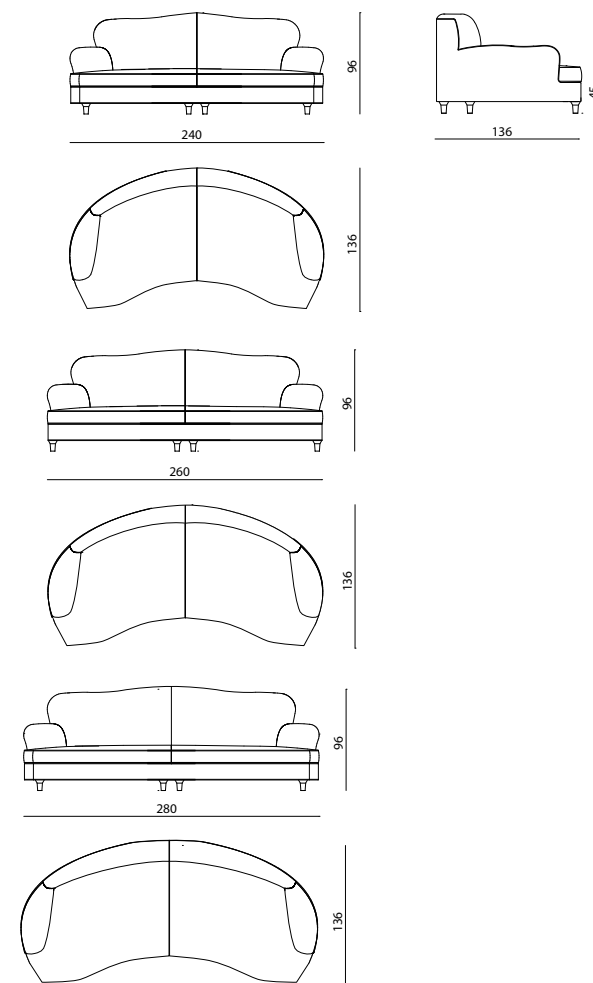

OBERON

DIVANO, POLTRONA - SOFA, ARMCHAIR

Roberto Lazzeroni

Struttura in multistrati e listellare di pioppo per sostegno parte superiore sagomata in massello di abete. Foderatura perimetrale in compensato di pioppo. Sedile cinghiato con nastri elastici. Tampone per spalliera, fronte e fasce esterne in poliuretano espanso portante. Parte interna spalliera con lavorazione capitonné. Parte frontale del bracciolo in agglomerato di poliuretano. Cuscini di seduta in poliuretano espanso doppia densità portante nella parte frontale ed elastico nella parte retrostante, con ricopertura in lastra di Memory Foam® e foderatura in piuma. Elementi decorativi in acciaio taglio laser di forma ovale con incisione stemma araldico Visionnaire. Zoccolo di base in multistrati di pioppo verniciato e rivestito con lamina in acciaio. Provvisto di piedini regolabili. Tappezzeria della scocca non sfoderabile, cuscini di seduta sfoderabili. Le parti metalliche sono disponibili nella selezione finiture metalliche.

Structure in poplar plywood and strips to support the shaped upper part in fir solid wood. Perimeter cover in poplar plywood. Seat made of elastic belts. Filling for back, front and external bands in rigid polyurethane. Internal structure padding with layer for capitonné working. Front part of the arm in polyurethane agglomerate. Seat cushions in polyurethane in double density in the frontal part and in the back part. Covered with Memory Foam® and layer in feather. Oval decorative elements in laser-cut steel, shiny finishing, with Visionnaire coat of arms. Plinth in painted poplar plywood, covered with steel laminate. Provided with adjustable feet. Structure upholstery not removable, seat cushions upholstery removable. Metal parts can be lacquered in any colour of the metal finish selection.

● click here

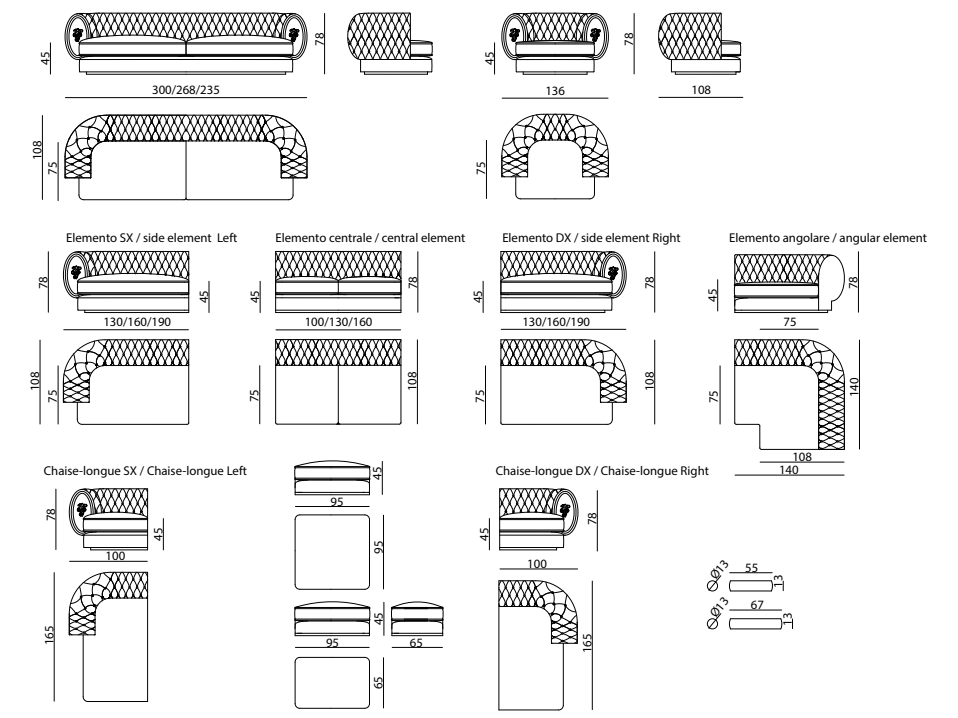



VALANCOURT

DIVANO - SOFA
 Maria Serebryanaya

Struttura in legno massello con imbottitura in poliuretano espanso. Divano rivestito in pelle o tessuto. Rivestimento fisso con lavorazione capitonné su schienale e braccioli. Ricamo stemma araldico Visionnaire sullo schienale. Cuscini di seduta in poliuretano, piuma d'oca e Memory Foam®. Mostrine decorative in acciaio inox lucido con stemma araldico in ottone inciso cromato, applicate sui braccioli. Basamento in MDF scanalato laccato lucido con supporti in plexiglass spessore 20 mm. Cuscini di seduta e schienale sfoderabili. Le parti metalliche sono disponibili nella selezione finiture metalliche.

Structure in solid wood and polyurethane foam. Sofa upholstered in leather or fabric. Upholstery not removable with capitonné finishing on backrest and armrest. Visionnaire coats of arms embroidered on backrest. Seat cushions in polyurethane foam, goose down and Memory Foam®. Patches in polished stainless steel with engraved coats of arms in chromed brass, applied as decoration on front armrest. Base in shiny carved lacquered MDF with feet in plexiglass th. 20 mm. Back and seat cushions cover removable. Metal parts can be lacquered in any colour of the metal finish selection.

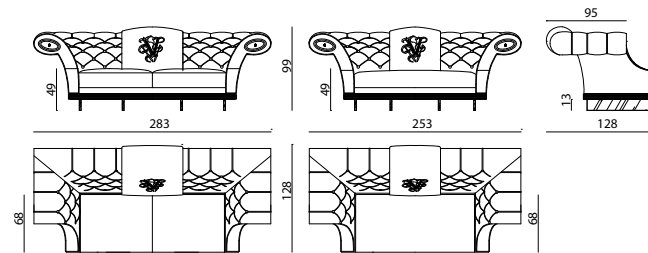
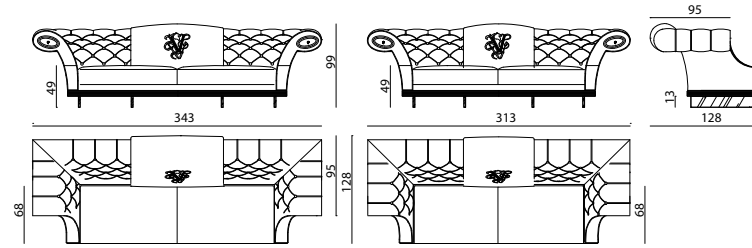

POLTRONA - ARMCHAIR

Poltrona in pelle o tessuto, rivestimento fisso. Fusto in legno massello e multistrati curvati con imbottitura in poliuretano espanso. Lavorazione capitonné sullo schienale, molleggio di seduta a cinghie elastiche. Cuscino di seduta in poliuretano, con inserto in piuma d'oca e Memory Foam®. Mostrine decorative in acciaio inox lucido con logo in ottone inciso cromato, applicate ai fianchi dello schienale. Basamento in MDF laccato lucido con piattaforma girevole in acciaio lucido. Cuscini di seduta e schienale sfoderabili. Le parti metalliche sono disponibili nella selezione finiture metalliche.

Armchair in leather or fabric, upholstery not removable. Frame in solid wood and curved multi plywood padded with expanded polyurethane. Backrest worked with capitonné patterns. Seat spring system with elastic belts. Seat cushion in polyurethane with inserts of goose down and Memory Foam®. Decorative trim in polished stainless steel with chromed carved logo are applied on the backrest sides. Plinth made of shiny lacquered MDF with a swivel platform in polished steel. Removable seat and back cushions' upholstery. Metal parts can be lacquered in any colour of the metal finish selection.

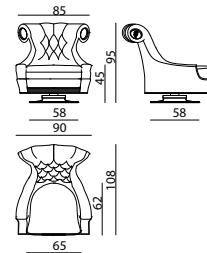

● [click here](#)

- click on the icons -



ADELE p.80



ALYA p.81



ARIES p.81



BACKSTAGE p.82



BLONDIE p.82



BLUEMINE p.83



CAMDEN p.83



CHEYNEY p.84



FOSTER p.84



GRACE p.85



IMAGINE p.85



JAMBOREE p.86



KHAMMA p.86



LEGEND p.87



MIRA p.87



PETRA p.88



ROSEMARY p.88



RUTH p.89



WHITNEY p.89



WUNJO p.90

- click on the icons -

ICONICI - *ICONIC*



AGON-AGON BIG p.92



ALICE p.92



GAILA p.93



MAC ARTHUR p.93



SONTAG p.94



WALLIS p.94

ART DESIGN



PAVONE p.648



PAVONE p.649



PAVONE p.650



ADELE

POLTRONA - ARMCHAIR

Marco Piva

Poltrona tappezzata in pelle o tessuto, struttura in legno multistrato curvato e massello dotata di molleggio a cinghie elastiche, imbottitura in poliuretano espanso a densità differenziate e fibra acrilica, tappezzeria con cuciture trapuntate, scocca esterna in pelle o tessuto con ricamo in all'over, seduta e schienale in pelle o tessuto, con profilo di separazione in alluminio cromo lucido, oro lucido o nichel nero satinato. Base in acciaio inox disponibile nei colori cromo, oro, champagne lucidi e nichel nero satinato.

Disponibile nella versione ADELE RADICA, con scocca esterna dello schienale in radica con finitura lucida 100 gloss.

Disponibile pouf abbinato, tappezzato in pelle o tessuto, con base in acciaio inox disponibile nei colori cromo, oro, champagne lucidi e nichel nero satinato.

Armchair upholstered in leather or fabric, structure in curved plywood and solid wood equipped with elastic spring belts, padding in polyurethane foam with different densities and acrylic fibre. Upholstery with quilted decoration, external structure covered in leather or fabric with all'over embroidery, seat and backrest in leather or fabric with dividing profile aluminium with polished chrome, or polished gold, or satin black nickel finish. Base in stainless steel available with polished chrome, gold, champagne and satin black nickel finish.

Available in the ADELE RADICA version, with external backrest shell in burr walnut with 100 gloss finish.

Available matching pouf, upholstered in leather or fabric, with stainless steel base available with polished chrome, gold, champagne and satin black nickel finish.

vedi anche/see also ADELE pouf-pouffe

● click here

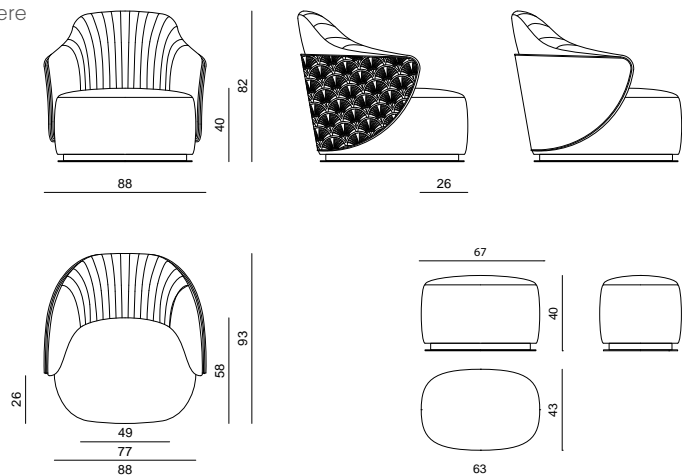

VERSIONE RADICA/ RADICA VERSION



ALYA

POLTRONCINA - ARMCHAIR

Steve Leung

Poltrona in pelle o tessuto. Scocca interna in legno multistrato e massello, imbottitura in poliuretano espanso a densità differenziate e fibra acrilica, tappezzeria retro schienale con disegno a losanghe trapuntate, interno seduta e schienale in pelle o tessuto con filetti. Telaio portante a vista formato da un traliccio di elementi in massello di frassino tinto a formare gambe e braccioli, interamente scolpito e levigato a mano. Telaio disponibile in opzione tinto lucido 100 gloss o verniciato a tinte lucide RAL/NCS. Piedi con basette in acciaio.

Armchair upholstered in leather or fabric. Internal structure in multiply and solid wood, padding in differentiated densities polyurethane and acrylic fiber, upholstery on rear back with quilted lozange pattern, internal back and seat upholstered in leather or fabric with pipings. Main frame on view made of elements in painted solid ash wood joined to form legs and arms, entirely carved and smoothed by hand. Main frame available in glossy ash solid wood or painted in glossy RAL/NCS colours. Feet with steel bases.

● click here

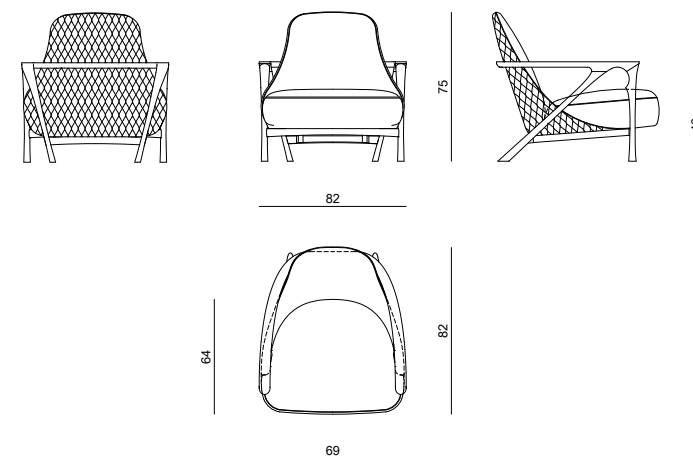

ARIES

POLTRONCINA - ARMCHAIR

Marco Draga & Aurel

Poltroncina tappezzata in pelle o tessuto. Fusto interno in legno multistrato imbottito in poliuretano a densità differenziate e rivestito in pelle o tessuto, basamento in metallo cromato e satinato di spessore 6 mm composto da due lamine piegate e unite tramite due borchie in ottone rifinite con due gemelli cilindrici in marmo e ottone cromato. Le parti in metallo sono disponibili nella selezione finiture metalliche.

Armchair upholstered in leather or fabric. Internal frame in multiply wood, padding in differentiated densities polyurethane, upholstery in leather or fabric. Base in satin chromed metal th. 6 mm made of two bent layers joined by two studs in brass, refined with two cufflinks in marble and chromed brass. The metal parts are available in the metal finishes selection.

● click here

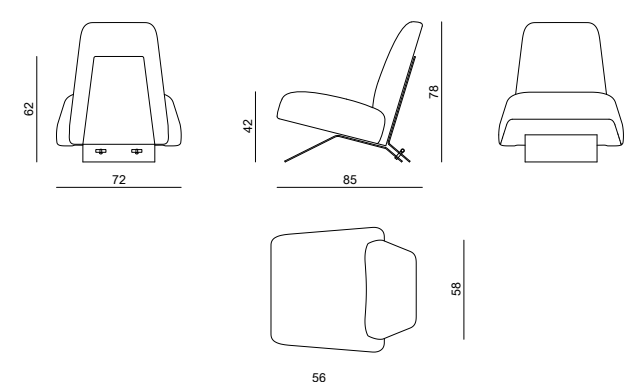



BACKSTAGE

POLTRONCINA - ARMCHAIR
Fabio Bonfà

Poltroncina tappezzata in pelle o tessuto, con base composta da un telaio in acciaio inox satinato e un pannello in legno e metallo rivestito in pelle o tessuto, dotato di cinghie elastiche per il molleggio del sedile. Scocca esterna in legno curvo bordato da un profilo in ottone sp.10x10 mm tappezzata con pelle, tessuto oppure pelle intrecciata, imbottita nella parte interna. Cuscino di seduta in poliuretano a diverse densità, memory foam® e piuma. Cuscino di schienale in poliuretano e piuma. Le parti metalliche sono disponibili nella selezione finiture metalliche satinato.

Disponibile nella versione BACKSTAGE RADICA con scocca esterna in radica finitura lucida 100 gloss.

Armchair upholstered in leather or fabric, with base composed of a frame in satinized stainless steel and a panel in wood and metal covered in leather or fabric, equipped with elastic belts for the seat suspension. External shell made of a curved wooden panel edged by a brass profile th.10x10 mm, and upholstered with leather, fabric or woven leather, padded inside. Seat cushion in polyurethane with different densities, memory foam® and feather. Back cushion in polyurethane and feather. Metal parts available in the satinized metal finishing selection.

Available in the BACKSTAGE RADICA version, with external shell in burr walnut with 100 gloss finish.

vedi anche/see also BACKSTAGE divano-sofa

● click here

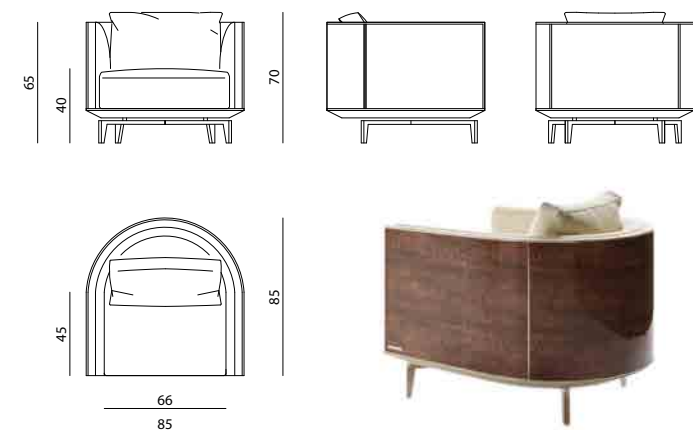

VERSIONE RADICA/ RADICA VERSION



BLONDIE

POLTRONA - ARMCHAIR
La Conca

Struttura in massello e multistrati di pioppo sagomato, imbottitura in poliuretano espanso a densità differenziate e molleggio seduta a cinghie elastiche. Seduta e schienale imbottite in Memory Foam® rivestiti internamente in pelle o tessuto trapuntato a porzioni singolarmente imbottite. Rivestimento esterno in pelle o tessuto liscio, filetti in pelle. Base e piedi in legno di faggio massello rivestito in essenza con angolari e piedini in acciaio inox satinato. Scocca e piedi sono disponibili nelle finiture selezione essenze; le parti metalliche sono disponibili nella selezione finiture metalliche satinato.

Structure in solid wood and shaped poplar plywood, padding in polyurethane foam with different densities and elastic straps springing system. Seat and backrest padded in Memory Foam® internally upholstered in leather or fabric, quilted portions padded one-by-one. External upholstery in leather or fabric, leather pipings. Base and feet in beech wood with corner profiles in satinized stainless steel. Base and feet are available in the veneer finishings selection; metal parts available in the satinized metal finishing selection.

vedi anche/see also BLONDIE panca-bench

● click here

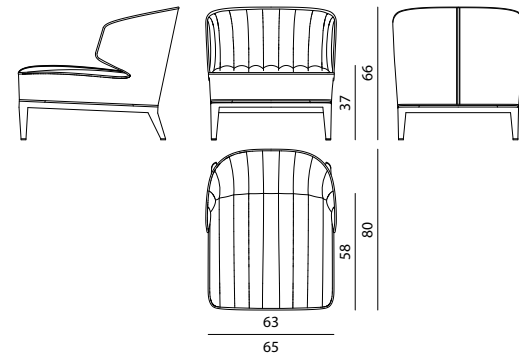

BLUEMINE

POLTRONA - ARMCHAIR
Fabio Bonfà

Poltrona in pelle o tessuto con scocca tappezzata in due toni. Fusto e schienale in multistrati e massello in legno con telaio di seduta molleggiato con cinghie elastiche e fusto di braccioli e schienale curvo. Imbottitura e cuscino in poliuretano a densità differenziate, telaio di seduta in legno raccordato con finitura in poliester lucido (colori RAL/NCS). Piedi e telaio inferiore in acciaio inox conificato disponibili nella selezione finiture metalliche satinato. Filetti sedile e schienale in pelle a contrasto. Cuscino reggireni con rivestimento a contrasto.

Armchair in leather or fabric with bi-colour upholstered structure. Structure and backrest in plywood and solid wood with seat frame webbed with elastic belts and curved armrest and backrest structure. Padding of external structure and cushion in polyurethane with different densities, seat frame in wood finished with glossy polyester coating (RAL/NCS colours). Feet and lower frame in conic stainless steel available with satin metal lacquered finish. Seat and back piping in contrasting leather. Small back cushions with contrasting upholstery.

● click here



CAMDEN

POLTRONA - ARMCHAIR
Mauro Lipparini

Poltroncina tappezzata con scocca in resina rivestita in pelle. Sedile interno in tre parti imbottito in poliuretano a diverse densità, rivestito in tessuto. Struttura portante in legno massello di noce canaletto con finitura naturale a poro aperto, scolpito in curva con sezione sagomata a tre lobi, parzialmente inserito nello schienale.

Small padded armchair. External structure in resin with leather upholstery. Seat divided in three parts, padding in polyurethane with different densities, upholstery in fabric. Supporting frame in Canaletto walnut solid wood with open-pore natural finish and shaped three-lobes section, partially embedded in the backrest.

Winner of the 2020 Architizer A+Awards, "Residential seating" category

● click here





CHEYNEY

POLTRONCINA GIREVOLE - SWIVEL ARMCHAIR

Mauro Lipparini

Struttura in metallo imbottita e tappezzata, schienale e seduta in poliuretano a densità differenziate, parte interna in Memory Foam® trapuntato. Rivestimento in pelle. Molleggio del sedile a cinghie elastiche. Base girevole in metallo a forma piramidale rivestita in acciaio inox satinato disponibile nella selezione finiture metalliche.

Structure in metal, padded and upholstered; backrest and seat in polyurethane in different densities; internal part in quilted Memory Foam®. Upholstery in leather. Seat with spring system with straps. Pyramidal swivel base in metal coated in satinized stainless steel, also available in the available in the metal finishing selection.

● click here

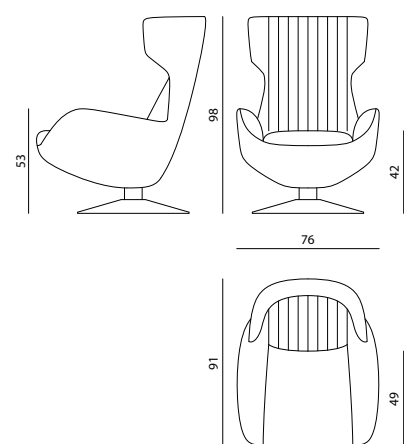

FOSTER

POLTRONCINA GIREVOLE - SWIVEL ARMCHAIR

Alessandro La Spada

Poltrona tappezzata in pelle o tessuto, fusto in legno massello e multistrato composto da una scocca con molleggio a cinghie elastiche per il sedile e da elementi curvi imbottiti per braccioli e schienale. Imbottitura in poliuretano a densità differenziate. Cuscino di schienale in piuma. Rivestimento esterno di fianchi e schienale con lavorazione trapuntata a canneté verticale. Basamento con sistema rotante auto-allineante. Zoccolo rivestito in metallo, disponibile in colore cromo satinato, oro satinato e siena satinato.

Armchair covered in leather or fabric. Main structure in solid and multiply wood consisting of a frame with elastic belt springing for seat and of curved padded elements for armrests and backrest. Padding in polyurethane with variable density. Seat cushions in feather. External sides and rearback with vertical canneté quilting. Base with self-aligning swivel system. Plinth covered in metal, available in satin chrome, satin gold and satin siena.

vedi anche/see also FOSTER divano-sofa, poltrona-armchair, tavolo basso-low table, dormeuse

● click here

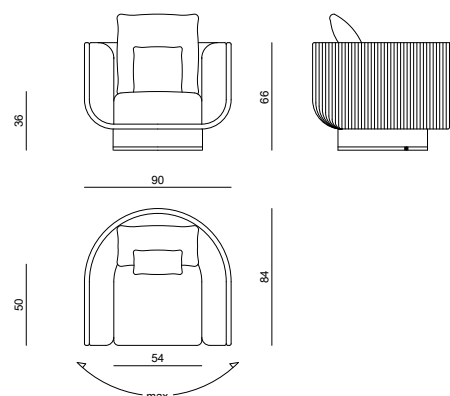

GRACE

POLTRONA, LOVE SEAT - ARMCHAIR, LOVE SEAT

Steve Leung

Poltrona e divanetto a doppia tappezzeria con struttura in legno massello e multistrati di pioppo. Imbottitura in poliuretano a densità differenziate con spalliera in pelle o tessuto liscio e parte inferiore trapuntata sia internamente che esternamente a grandi fasce imbottite. Base in acciaio satinato e gambe anteriori in alluminio satinato. Le parti metalliche sono disponibili nella versione "colorazione GRACE" e su richiesta nella selezione finiture metalliche satiniate.

Armchair and love seat with double upholstery, structure in solid wood and poplar plywood. Padding in polyurethane with different densities, backrest in leather or fabric and lower part quilted in large stripes both internally and externally. Satinized steel base and aluminium legs. Metal parts available in the "GRACE colour" version and upon request in the satinized metal finishing selection.

vedi anche/see also GRACE pouf-pouffe

● click here

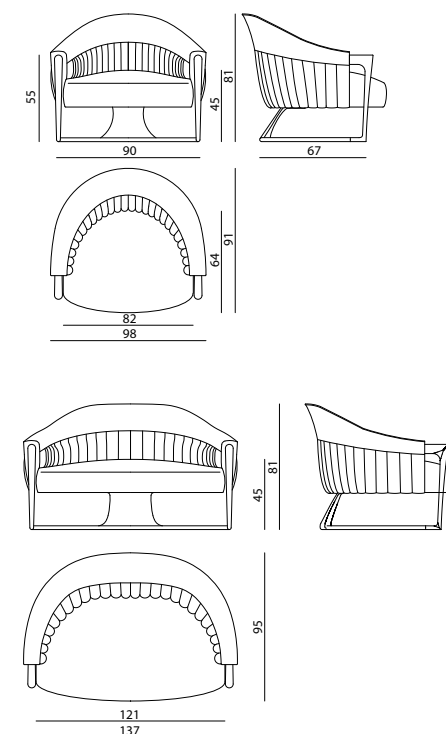

IMAGINE

BERGÈRE - BERGÈRE

Mauro Lipparini

Poltrona bergère tappezzata in pelle o tessuto. Struttura della seduta in multistrati di pioppo con molleggio a cinghie elastiche, imbottita in poliuretano a densità differenziate. Braccioli in lamina metallica rivestiti in pelle, gambe in legno laccato nero lucido con filetto decorativo e piedi in metallo disponibili nella selezione finiture metalliche.

Armchair upholstered in leather or fabric. Seat structure in poplar plywood with elastic spring belts, padding in polyurethane foam with different densities. Armrests in metal sheet covered in leather, legs in wood with polish black lacquer and decorative piping, metal feet can be lacquered with any colour included in the metal finish selection.

● click here

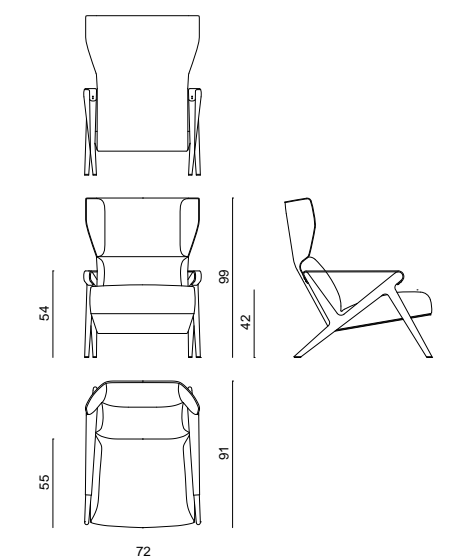



JAMBOREE

POLTRONCINA - ARMCHAIR
Alessandro La Spada

Poltroncina con tappezzeria fissa in pelle o tessuto, fusto in legno multistrati e massello con cinghiature elastiche, imbottitura in poliuretano a diverse densità, Memory Foam® e piuma. La scocca esterna è formata da pannelli leggermente imbottiti e rivestiti. Cuscini volanti in piuma. Piedi in acciaio inox con sagoma a coda di rondine. Le parti in metallo sono disponibili nella selezione finiture metalliche.

Small armchair with non-removable upholstery in leather or fabric; frame in plywood and solid wood with elastic webbing belts; padding in polyurethane with different densities, Memory Foam® and feather. External structure consisting of slightly padded panels covered with upholstery. Loose cushions in feather. Feet in stainless steel with dove-tail shape. Metal parts can be finished in any lacquer of the metal lacquer finish selection.

vedi anche/see also JAMBOREE divano, poltrona-sofa, armchair, JAMBOREE tavolino-low table

● click here

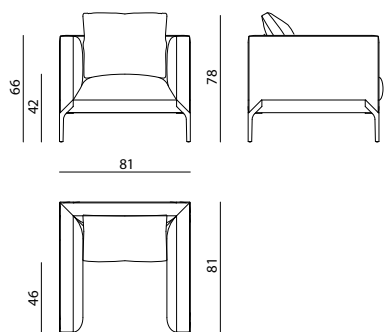

KHAMMA

POLTRONCINA - ARMCHAIR
La Conca

Poltrona in pelle o tessuto, fusto in multistrati e massello di legno con telaio di seduta molleggiato con cinghie elastiche e fusto di braccioli e schienale curvo. Imbottitura della scocca e cuscini di seduta in poliuretano a densità differenziate e falda acrilica. Cuscino di schienale in piuma. Filetti a contrasto in pelle e logo Visionnaire ricamato sul cuscino di schienale. Basamento tubolare in acciaio inox disponibile nella selezione finiture metalliche satinata, con attacco centrale e sistema rotante auto allineante.

Armchair in leather or fabric with bi-colour upholstered structure. Structure and backrest in plywood and solid wood with seat frame webbed with elastic belts and curved armrest and backrest structure. Padding of external structure and seat cushion in polyurethane with different densities and acrylic fiber. Back cushion in feather. Piping in contrasting leather and logo embroidered on the small back cushion. Tubular base in stainless steel available with satin metal lacquered finish, fixed to the centre of the underseat structure and equipped with self-aligning rotating system.

● click here

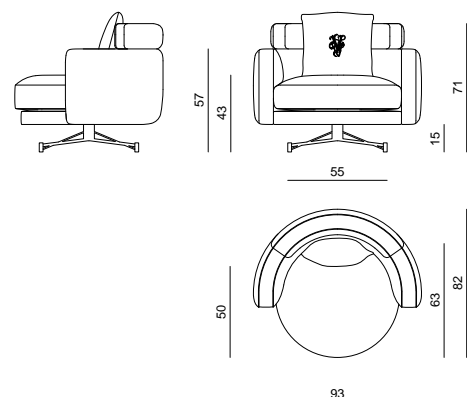

LEGEND QUILTED

POLTRONA - ARMCHAIR
Fabio Bonfà

Struttura in legno massello e multistrati con molleggio a cinghie elastiche, imbottitura in poliuretano a densità differenziate. Rivestimento in pelle o tessuto. Retro schienale trapuntato. Piedi posteriori rivestiti in pelle o tessuto. Base e piedi anteriori in acciaio inox satinato sono disponibili nella selezione finiture metalliche.

Structure in solid wood and plywood with elastic straps, padding in polyurethane with different densities. Upholstered in leather or fabric. Quilted backrest. Rear feet upholstered in leather or fabric. Base and front feet in satinized stainless steel available in the metal finishing selection.

vedi anche/see also LEGEND divano-sofa

● click here

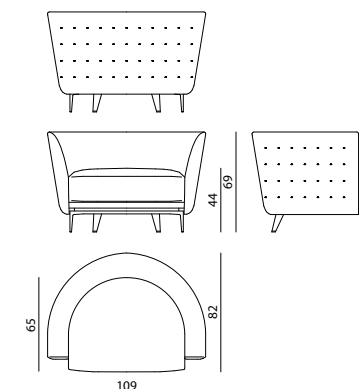

MIRA

POLTRONA - ARMCHAIR
Draga & Aurel

Poltroncina tappezzata in pelle o tessuto. Fusto interno in legno multistrati imbottito in poliuretano a densità differenziate a volumi bombati, staffa di attacco schienale in fusione di alluminio satinato con finitura "orbitale". Le parti in metallo sono disponibili nella selezione finiture metalliche.

Armchair upholstered in leather or fabric. Internal frame in multilayer wood padded with differentiated density polyurethane with rounded volumes, backrest fixing bracket in satin-finish cast aluminium with "orbital" finish. Metal parts are available in the metal finishing selection.

● click here

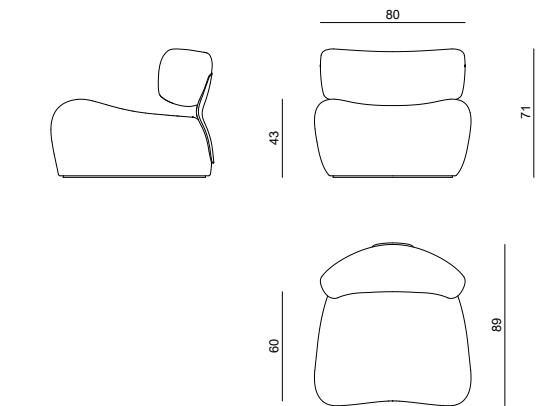



PETRA

POLTRONA - ARMCHAIR
Alessandro La Spada

Poltrona in pelle o tessuto, scocca in legno curvato dotata di molleggio elastico per la seduta. Elementi strutturali verticali in acciaio inox nello schienale e sui braccioli. Rivestimento della scocca a motivo geometrico con filetti in pelle Soft leather di finitura. Le parti metalliche sono disponibili nella selezione finiture metalliche.

Armchair in leather and fabric, external structure in curved wood equipped with elastic spring belts. Backrest and armrest provided with vertical structural elements in stainless steel. External structure upholstered with a geometrical pattern and piping in Soft leather. Metal parts can be lacquered in any colour included in the metal finish selection.

● click here

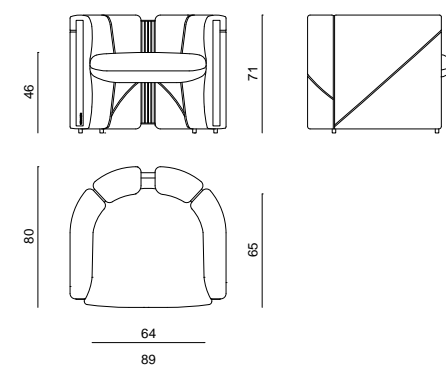

ROSEMARY

POLTRONA - ARMCHAIR
Alessandro La Spada

Struttura di sedile e schienale in multistrato curvato, molleggio a cinghie elastiche, struttura di base in multistrato di pioppo e massello di faggio, rivestimento in pelle o tessuto. Imbottitura interna in poliuretano a densità differenziate e Memory Foam®, rivestito con guscio in cotone anti-piuma riempito in piumino. Rivestimento esterno trapuntato con disegno "cannette". Fregi decorativi e piedi anteriori in acciaio inox satinato. Le parti metalliche sono disponibili nella selezione finiture metalliche satinato.

Disponibile nella versione ROSEMARY RADICA con parte alta posteriore dello schienale in radica con finitura lucida 100 gloss.

Seat and backrest structure in curved plywood, elastic straps springing system; base structure in poplar plywood and beech solid wood, upholstery in leather or fabric. Internal padding in polyurethane with different densities and Memory Foam®, embedded within a feather-proof lining, filled with down. External upholstery quilted with cannette motive. Decorative friezes and front feet in satinized stainless steel. Metal parts available in the satinized metal finishing selection.

Available in the ROSEMARY RADICA version with the upper back in burr walnut with a 100 gloss finish

● click here



VERSIONE RADICA/ RADICA VERSION

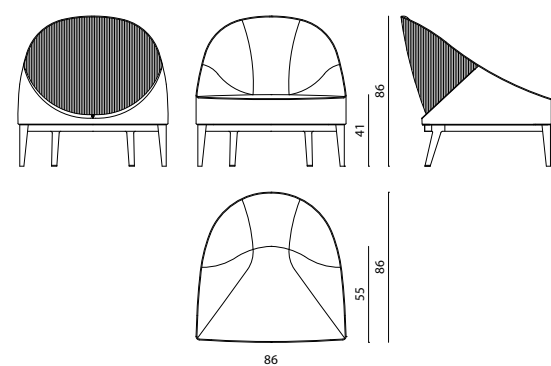

RUTH

POLTRONCINA - ARMCHAIR
Steve Leung

Poltrona in pelle o tessuto. Struttura in legno multistrato e massello, imbottitura in poliuretano espanso a densità differenziate e fibra acrilica, tappezzeria retro schienale con disegno a losanghe trapuntate, interno seduta e schienale in pelle o tessuto con filetti. Base in massello di frassino tinto formata da una cornice sagomata e quattro piedi conici raccordati alla cornice, muniti di basette in acciaio. Base disponibile in opzione in massello di frassino tinto lucido 100 gloss o verniciato a tinte lucide RAL/NCS.

Armchair in leather or fabric. Frame made of multilayer and solid wood, padding in differentiated density polyurethane foam and acrylic fibre, upholstery behind backrest with quilted lozenge pattern, seat and backrest upholstery in leather or fabric with piping. Base in solid stained ash formed by a shaped frame and four conical feet connected to the frame, fitted with steel feet. Base available in glossy ash solid wood or painted in glossy RAL/NCS colours.

● click here

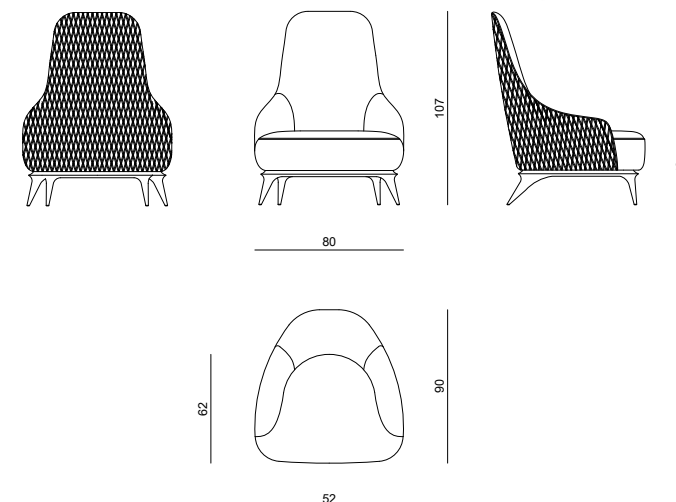

WHITNEY

POLTRONA - ARMCHAIR
Fabio Bonfà

Poltrona tappezzata in pelle o tessuto, struttura in legno multistrato curvato e massello dotata di molleggio a cinghie elastiche, imbottitura in poliuretano espanso a densità differenziate e fibra acrilica, tappezzeria con cuciture trapuntate, scocca esterna in pelle o tessuto con ricamo cannette, seduta e schienale in pelle o tessuto a contrasto. Struttura di base in acciaio inox disponibile nella selezione finiture metalliche.

Armchair upholstered in leather or fabric, structure in curved plywood and solid wood equipped with elastic spring belts, padding in polyurethane foam with different densities, externally covered in leather or fabric with cannette quilted decoration, seat and backrest in contrasting leather and fabric. Base structure in stainless steel available with any finish included in the metal finish selection.

● click here

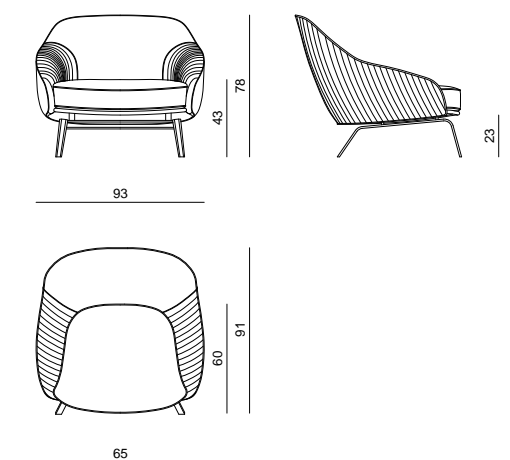



WUNJO

POLTRONA - ARMCHAIR

Steve Leung

Struttura in legno multistrato e massello, imbottitura in poliuretano espanso a densità differenziate, Memory Foam® e fibra acrilica, tappezzeria di schienale con disegno a losanghe trapuntate. Cuscino reggi-reni in piuma, piedi anteriori in alluminio tornito finitura cromo oppure oro o bronzo, posteriori rivestiti in pelle o tessuto. Opzione: inserto decorativo nel bracciolo in pietra semipreziosa o in radica/essenza.

Structure in plywood and in solid wood, polyurethane foam in different densities Memory Foam® and acrylic fibre padding, backrest upholstery with capitonné rhombus pattern and seat cushion with light quilting. Back cushion in goose down, front feet in turned aluminium in chromed/golden/bronzed finishing and rear feet covered with fabric or leather. Option: decorative insert in the armrest in semi-precious stone or briar wood/veneer.

● click here

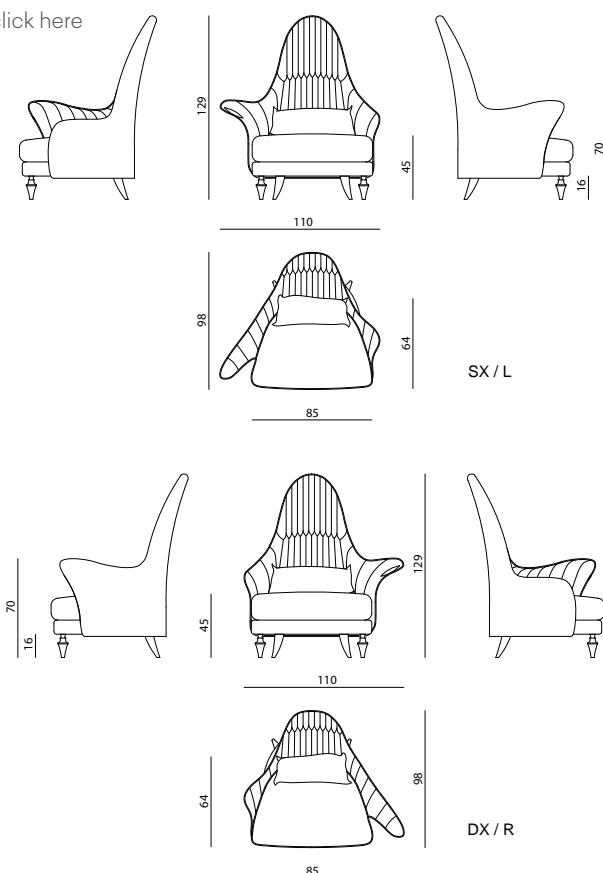



AGON, AGON BIG

POLTRONA - ARMCHAIR
Roberto Lazzeroni

Struttura in multistrati e compensato di pioppo con tamponatura esterna in poliuretano. Molleggio seduta a cinghie elastiche con imbottitura del cuscino in poliuretano. Imbottitura dello schienale in poliuretano. Ricopertura della scocca con falda in fibra di poliestere. Basamento in massello di pioppo tappezzato in pelle o tessuto. Rivestimento capitonné non sfoderabile.
Opzione: base girevole.

Structure in plywood and poplar compensated with external closing panels in polyurethane. Seat suspension with elastic belts with cushion padding in polyurethane. Back padding in polyurethane. Cover of frame with layers of polyester fibre. Base in solid poplar, upholstered in leather or fabric. Cover capitonné not removable.
Option: swivel base.

● click here

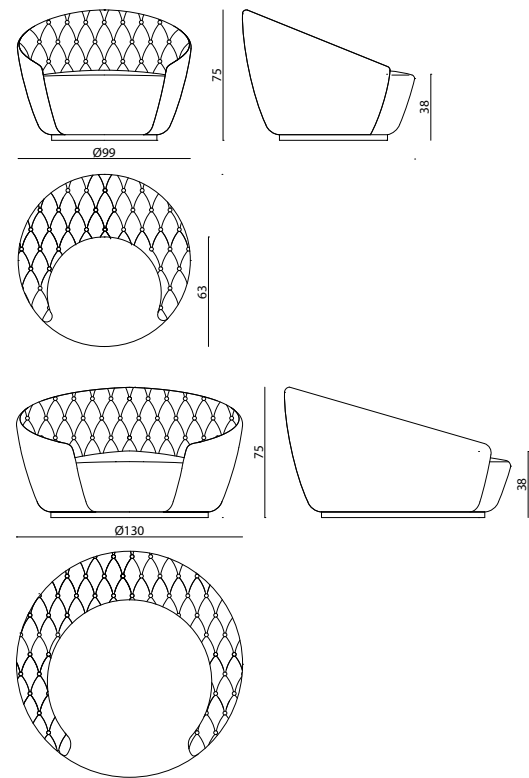

ALICE

POLTRONA - ARMCHAIR
Alessandro La Spada

Struttura portante in massello di faggio e compensato. Piano seduta con molleggio a nastri elastici su telaio in faggio. Imbottitura schienale in poliuretano espanso. Braccioli in poliuretano espanso. Cuscini seduta in poliuretano espanso a quote differenziate, semi-rigido nella parte inferiore e morbido nella parte superiore. Retro-schienale e fianchi con rivestimento accoppiato a falda di fibra acrilica con supporto in vellutino acrilico. Tappezzeria fianchi esterni braccioli e bordo parte alta schienale con bottoni, effetto capitonné. Gambe anteriori e posteriori rivestite in pelle o tessuto. Le gambe anteriori sono decorate con anelli in ottone tornito con incisione motivo ovali e medaglione ovale in ottone, con incisione stemma araldico Visionnaire.
Opzione: ricamo stemma araldico Visionnaire sullo schienale.

Main structure in beech solid wood and plywood. Seat provided with sprung system made of elastic belts on beech frame. Padding of the back in polyurethane. Arms in polyurethane. Seat cushions in polyurethane in different densities, semirigid in the lower part and soft in the upper part. Cover of rear back and sides coupled to acrylic lining, with support in acrylic velvet. Upholstery of the arms external sides and of the back high border with buttons with capitonné effect. Front and rear legs covered with leather or fabric. The front legs are decorated with rings in turned brass with oval pattern engraving and oval medal in brass, with Visionnaire coats of arms carving.
Option: Visionnaire coats of arms embroidery.

vedi anche/see also ALICE chaise-longue, ALICE panca-bench, ALICE comodino-bedside table, ALICE cassetiera-chest of drawers

● click here

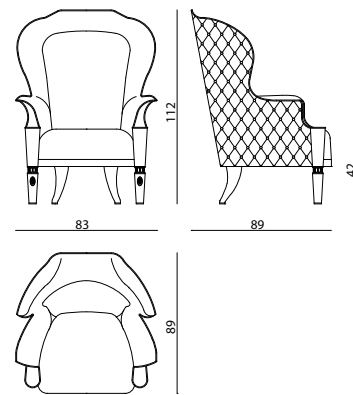

GAILA

POLTRONA, POUF - ARMCHAIR, POUFFE
Alessandro La Spada

Gambe anteriori, bracciolo e piede posteriore in ottone conifcato e curvato, rivestito in cuoio. Terminali delle gambe e logo sul bracciolo in ottone cromato. Struttura della seduta in multistrati di pioppo con molleggio a cinghie elastiche, cuscino di seduta in poliuretano a densità differenziate. Le parti metalliche sono disponibili nella selezione finiture metalliche. Rivestimento in pelle o tessuto.

Front legs, armrest and back feet in conical curved brass covered in leather. Legs tips and armrest logo in chromed brass. Poplar plywood seat structure with sprung system with straps. Seat cushion in polyurethane in different densities. Metal parts can be lacquered in any colour of the metal finish selection. Upholstery in leather or fabric.

● click here

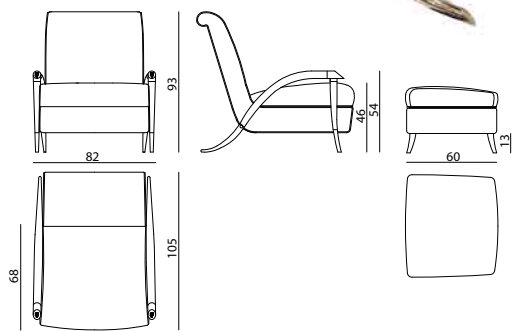

MAC ARTHUR

POLTRONA - ARMCHAIR
Alessandro La Spada

Struttura in multistrato di pioppo curvato. Molleggio di seduta con cinghie elastiche ricoperte da un'imbottitura di poliuretano espanso, con uno strato di Memory Foam® e falda acrilica. Base in acciaio inox lucidato oppure opzione laccato oro/bronzo, con sistema girevole. Rivestimento in pelle o tessuto non sfoderabile. Su richiesta possibilità di ricamo "lindoro" sui fianchi e/o logo "Visionnaire" sul retro.

Structure in curved poplar plywood. Seating sprung system with elastic belts covered with a padding of polyurethane foam, a layer of Memory Foam® and acrylic. Base in polished stainless steel or gold/bronze lacquer, with swivel system. Upholstery in fabric or leather not removable. On request, as optional, "lindoro" embroidery can be applied over each side and "Visionnaire" logo embroidered on the rear.

● click here

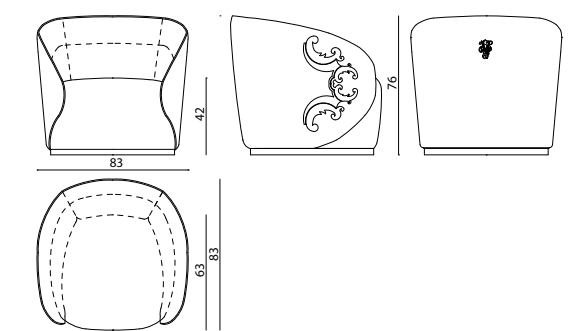



SONTAG

POLTRONA - ARMCHAIR
Samuele Mazza

Struttura in legno massello e multistrati sfaccettata "a diamante", molleggio di seduta con cinghie elastiche e imbottitura di poliuretano, Memory Foam® e falda acrilica. Parte interna dello schienale in poliuretano e falda acrilica con porzioni singolarmente imbottite. Base sfaccettata girevole in acciaio inox lucidato disponibile nella selezione finiture metalliche.

"Diamond" shaped structure in solid wood and plywood, seat with spring system with straps and padding in polyurethane, Memory Foam® and acrylic fibre. Internal parts of the back in polyurethane and acrylic fibres padded individually. Multi-faceted base in polished stainless steel available in the metal finishing selection.

vedi anche/see also SONTAG pouf-pouffe

● [click here](#)

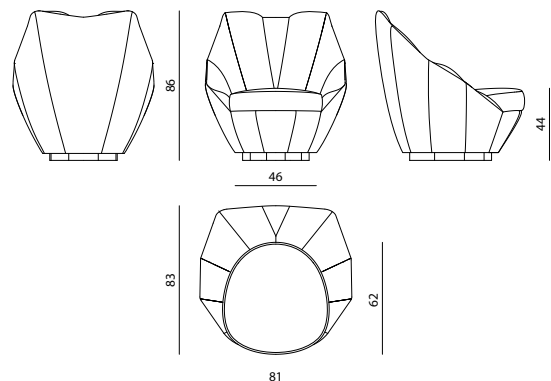

WALLIS

POLTRONA - ARMCHAIR
La Conca

Poltrona rivestita in pelle o tessuto, rivestimento fisso. Struttura in massello di abete e multistrati di pioppo, molleggio a cinghie elastiche, imbottitura in poliuretano espanso con lavorazione capitonné sullo schienale. Cuscino di seduta con inserti in piuma d'oca e Memory Foam®. Frontali dei braccioli in multistrati riportati e rivestiti in pelle o tessuto con fregio in ottone cromato, piedi in torneria di alluminio cromato parzialmente rivestite in pelle. Le parti metalliche sono disponibili nella selezione finiture metalliche.

Armchair upholstered in fabric or leather not removable. Structure in solid pinewood and poplar plywood. Spring system with elastic belts. Expanded polyurethane padding. Capitoné pattern on the backrest. Seat cushions with goose down and Memory Foam® inserts. Front armrest in plywood upholstered in leather or fabric with chromed brass decorations, turned and chromed aluminium feet partially upholstered in leather. Metal parts can be lacquered in any colour of the metal finish selection.

● [click here](#)

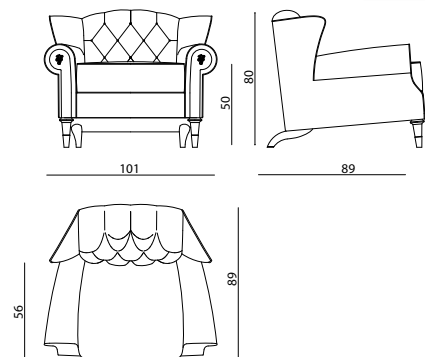

- click on the icons -



BLAZING p.98



CITIZEN p.98



DEIMOS p.99



DUBHE p.99



EGOISTE p.100



KLIPPER p.100



SHINÒ p.101



SVEVA CAPITONÉ p.101



TIWAY p.102



VANITY FAIR p.102

ICONICI - *ICONIC*



ALICE p.104



HEMINGWAY p.105



BLAZING

CHAISE-LONGUE - CHAISE-LONGUE

Alessandro La Spada

Struttura mista in legno e metallo con molleggio a cinghie elastiche, imbottitura in poliuretano a densità differenziate. Cuscino di seduta in poliuretano, Memory Foam® e piuma. Cuscini volanti in piuma. Rivestimento in pelle o tessuto. Ripiano portaoggetti in marmo. Gambe e inserti in acciaio inox satinato disponibili nella selezione finiture metalliche.

Wooden and metal structure with spring system with straps; padding in polyurethane foam in different densities. Seat cushion in polyurethane, Memory Foam® and goose down. Loose cushions in feather. Upholstery in leather or fabric. Side shelf in marble. Legs and inserts in satinized stainless steel, available in the metal finishing selection.

● click here

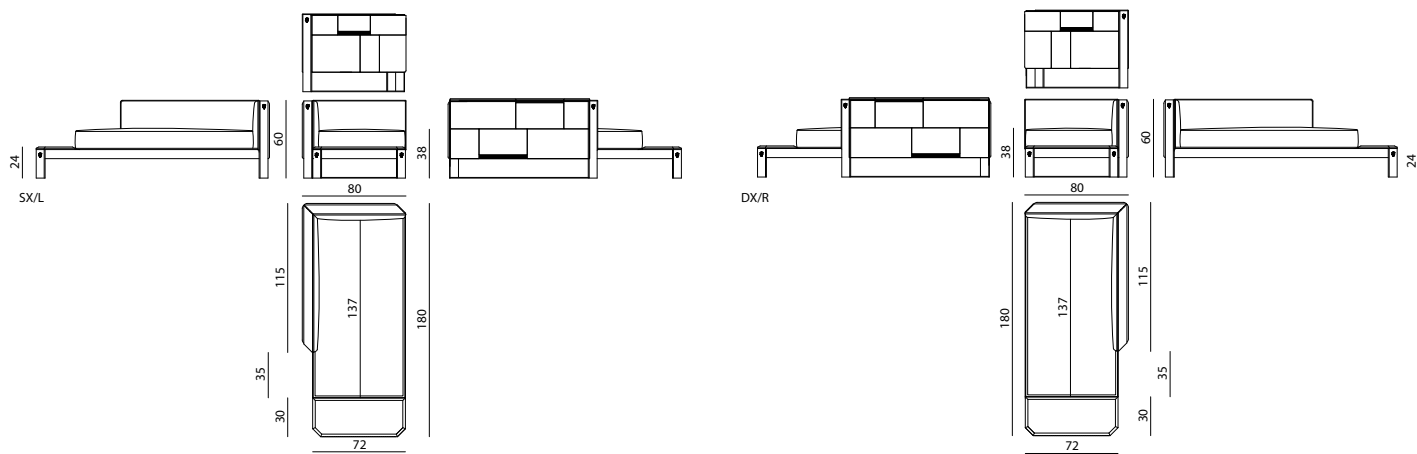

DEIMOS

CHAISE-LONGUE - CHAISE-LONGUE

Steve Leung

Dormeuse tappezzata in pelle o tessuto. Fusto in legno curvato e sagomato in masselli e multistrati, rivestito esternamente in poliuretano rigido sagomato con superfici esterne concave e convexe. Interno braccioli e schienale in poliuretano bombato e sedile in poliuretano a densità differenziate e falda acrilica, con molleggio a cinghie elastiche. Scocca portante in legno di frassino massello tinto opaco, con basette in acciaio. Disponibile in opzione scocca in legno di frassino massello tinto lucido 100 gloss.

Dormeuse upholstered in leather or fabric. Curved and shaped frame in solid and multiply wood, externally covered in rigid shaped polyurethane with concave and curved external surfaces. Internal armrests and backrest in convex polyurethane and seat in polyurethane with variable density and acrylic layer, with elastic belt springing. Body in mat painted ash solid wood, with steel feet. Optionally available solid ash wood shell stained 100 gloss.

vedi anche/see also DEIMOS divano, poltrona-sofa

● click here

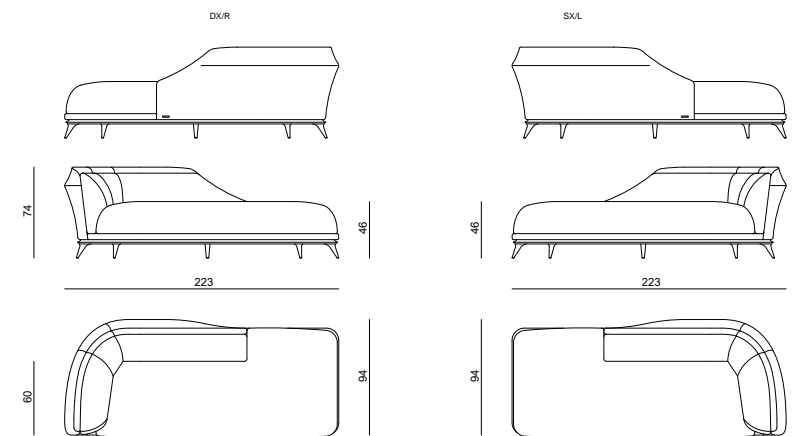

CITIZEN CITIZEN ACTION

CHAISE-LONGUE - CHAISE-LONGUE

Mauro Lipparini

Struttura interna in legno massello e multistrati con molleggio a cinghie elastiche, imbottitura del sedile, schienale e braccioli in poliuretano espanso a densità differenziate, Memory Foam® e falda acrilica. Rivestimento in pelle o tessuto. Basamento ligneo rivestito in acciaio inox satinato. Nella versione con un bracciolo, fregio decorativo sulla parte inclinata dello schienale in acciaio inox satinato, con logo in ottone cromato. Le parti in metallo sono disponibili nella sezione finiture metalliche satinato. Su richiesta, sono disponibili cuscini volanti tondi Ø35 cm e rettangolari 35x40 cm in piuma, rivestiti in pelle o tessuto, con filetto. Disponibile in versione CITIZEN ACTION con rivestimento a lavorazione canneté su seduta e schienale.

Internal structure in solid wood and plywood, equipped with spring system with straps; seat, backrest and armrests padded in polyurethane foam in different densities, Memory Foam® and acrylic fibre. Upholstery in leather or fabric. Wooden base coated in satinized stainless steel. In the one-armrest version, decorative coat of arms on the oblique part of the backrest in satinized stainless steel. Metal parts available in the satinized metal finishing selection. Upon request, available loose round cushions Ø35 cm and rectangular cushions 35x40 cm filled in feather, upholstered in leather or fabric. Available in Action version, with seat and back upholstery finished with canneté quilted motif.

vedi anche/see also CITIZEN divano, poltrona-sofa, armchair, CITIZEN pouf-pouff

● click here

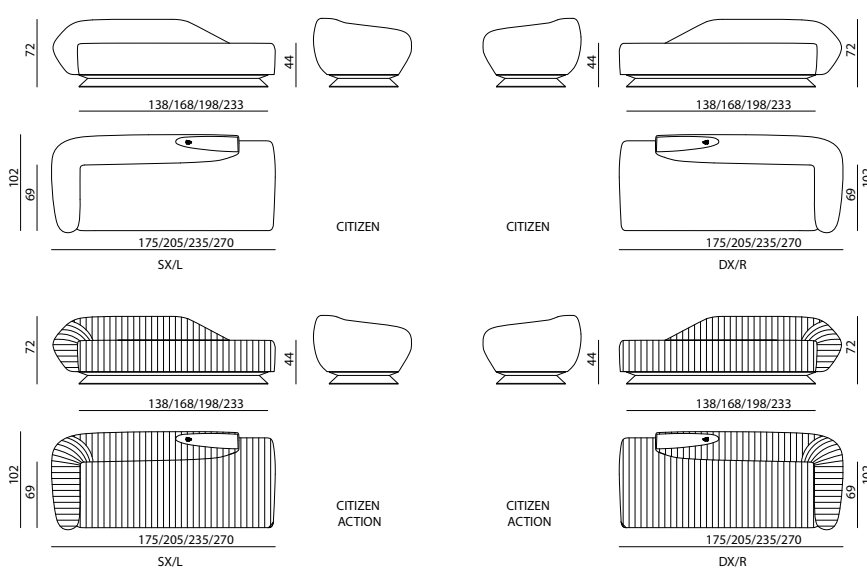

DUBHE

ORSO CHAISE-LONGUE - BEAR CHAISE-LONGUE

Samuele Mazza

Piano di base in compensato multistrati. Imbottitura in poliuretano espanso a quote differenziate e falda di fibra acrilica. Rivestimento in pelliccia ecologica elasticizzata, con catena decorativa e placchetta Visionnaire.

Base in plywood. Padding in polyurethane of different densities and acrylic fibre layer. Cover in stretch ecological fur, with decorative chain and Visionnaire plate.

● click here

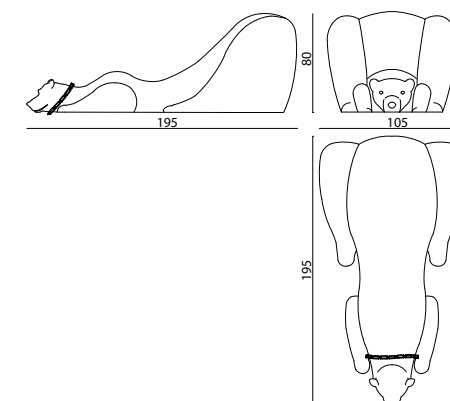

EGOISTE

CHAISE-LONGUE - CHAISE-LONGUE

Alessandro La Spada

Chaise-longue con scocca in legno multistrati di betulla imbottito in poliuretano e falda acrilica, tappezzata in pelle o tessuto, telaio portante in acciaio inox satinato, disponibile nella selezione finiture metalliche.

Chaise-longue with structure in birch plywood, padded in polyurethane foam and acrylic fiber. Upholstery in leather or fabric, supporting frame in stainless steel - available in any of the lacquer included in the satinized metal finish selection.

● [click here](#)

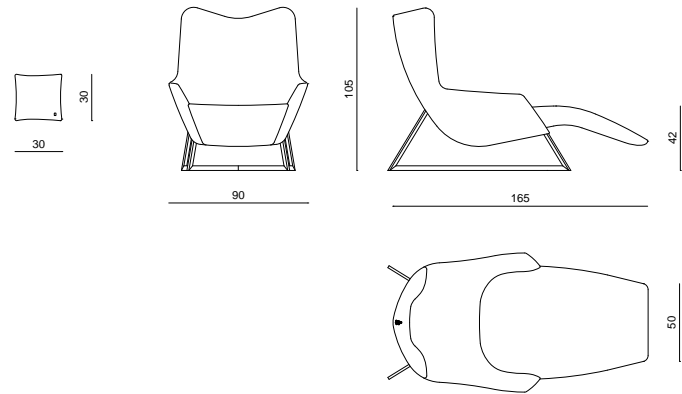

SHINÒ

CHAISE-ROND - CHAISE-ROND

Domenico De Palo

Struttura di seduta in multistrati e masselli di abete, imbottitura in poliuretano espanso a densità differenziate, Memory Foam® e fibra acrilica, molleggio con cinghie elastiche. Cuscini fissi di schienale in piuma d'oca con struttura interna in doghe di faggio che si innestano nella base. Rivestimento in pelle o tessuto, basamento in acciaio inox. Le parti metalliche sono disponibili nella selezione finiture metalliche.

Seat structure in plywood and solid fir wood, padding in polyurethane in different densities, Memory Foam® and acrylic fibre, sprung system with elastic straps. Fixed backrest cushions with goose down filling and internal beech modular slats which lock into the base. Upholstery in fabric or leather, base in stainless steel. Metal parts available in the metal finishing selection.

● [click here](#)

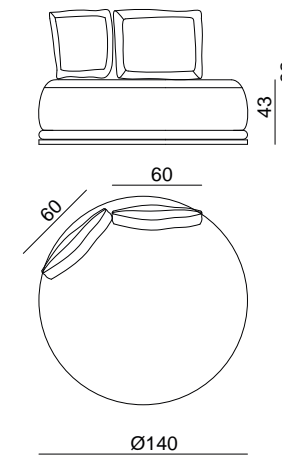

KLIPPER

POUF CANE - DOG POUFFE

Samuele Mazza

Seduta informale con struttura in legno di multistrati e imbottitura in poliuretano espanso. Rinfascio in falda di ovatta acrilica. Rivestimento in lana Mongolia non sfoderabile. Piedini antiscivolo.

Informal seat unit. Structure in plywood and padding in expanded polyurethane. External layer in acrylic cotton wool. Non removable mongolian wool cover. Nonslip feet.

● [click here](#)

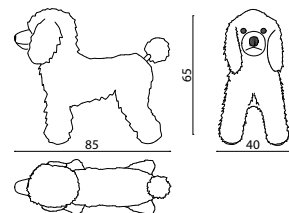

SVEVA CAPITONNÉ

CHAISE-LONGUE - CHAISE-LONGUE

Giuseppe Viganò

Struttura in multistrati di pioppo con rinforzo in metallo per fissaggio gambe. Imbottitura poliuretano espanso a doppia densità, per lavorazione capitonné. Profilo esterno in poliuretano portante. Foderatura in falda acrilica. Guanciale appoggiatesta 60x30 cm in piuma con filetto e con fascette di fissaggio in pelle. Rivestimento in tessuto o pelle con filetto a contrasto. Cappottina a soffietto, ad inclinazione regolabile, in tessuto a pizzo. Gambe e tornerie in alluminio tornito finitura lucida. Le parti metalliche sono disponibili nella selezione finiture metalliche.

Structure in poplar plywood with support in metal for legs fixing. Padding in polyurethane in double density, for capitonné working. External profile in rigid polyurethane. Headrest cushion 60x30 cm in feather with pipings and with fixing bands. Upholstered with fabric or leather and with pipings. Sliding roof with adjustable inclination in fabric. Legs and turnings in shiny aluminium.

Metal parts can be lacquered in any colour of the metal finish selection, and turnings in shiny aluminium.

vedi anche/see also SVEVA dehors

● [click here](#)

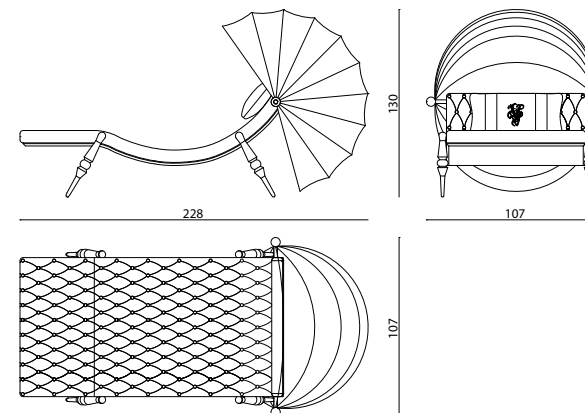



TIWAY

CHAISE-LONGUE - CHAISE-LONGUE

Steve Leung

Struttura in legno multistrato e massello, imbottitura in poliuretano espanso a densità differenziate e fibra acrilica, tappezzeria di schienale con disegno a losanghe capitonné. Cuscino di seduta capitonné. Cuscino reggi-reni in piuma, piedi in alluminio tornito finitura lucido. Le parti metalliche sono disponibili nella selezione finiture metalliche.

Structure in plywood and solid wood, polyurethane foam in different densities and acrylic fibre padding, backrest upholstery with capitonné rhombus pattern. Seat cushion with light quilting. Back cushion in goose down, feet in turned aluminium in polished finishing. Metal parts can be lacquered in any colour of the metal finish selection.

● [click here](#)

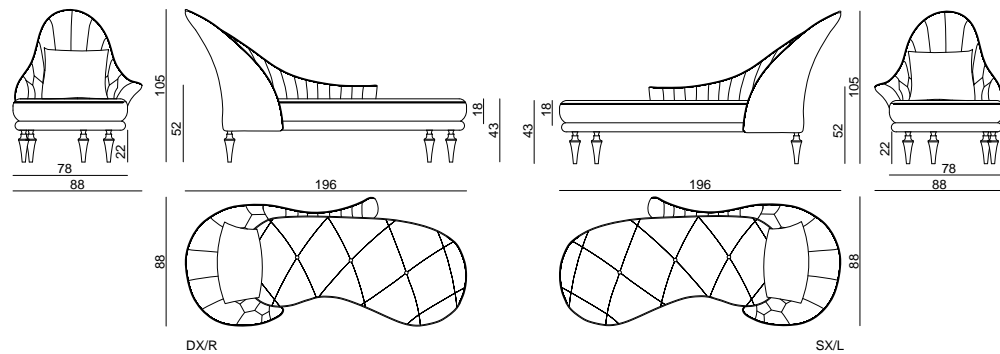

VANITY FAIR

CHAISE LONGUE - CHAISE LONGUE

Giuseppe Viganò

Struttura portante sagomata in ferro smaltato e maglia metallica, imbottita in poliuretano espanso, molleggio seduta a cinghie elastiche. Rivestimento fisso in pelle o tessuto e cover sfoderabile double face, con leggera trapuntatura in piuma d'oca e sistema di chiusura con alamari nascosti. Gambe in ferro conificato smaltato ed elementi di finitura in alluminio tornito e cromato. Loghi Visionnaire sulle gambe posteriori in ottone cromato. La pelliccia è disponibile in finitura naturale su base grigia o marrone, o tinta tortora, le parti metalliche sono disponibili nella selezione finiture metalliche.

Main structure in moulded enamelled iron and metallic mail padded in expanded polyurethane. Seat spring system with elastic belts. Body upholstery in leather or fabric not removable. Removable cover double face, lightly quilted with goose down and closed by hidden frog. Legs in enamelled iron with conic shape. Finishing elements in turned and chromed aluminium. Visionnaire logos in chromed brass over the back legs. The fur coating is available in natural finishing on a gray or brown base or in dove-gray colour. Metal parts available in the metal finishing selection.

vedi anche/see also VANITY FAIR divano poltrona-sofa, armchair, VANITY FAIR pouf-pouffe

● [click here](#)

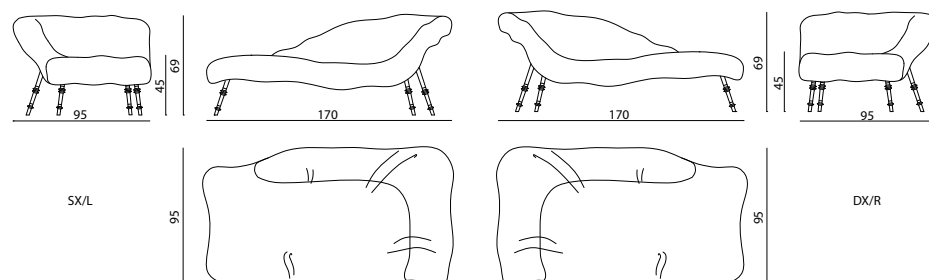

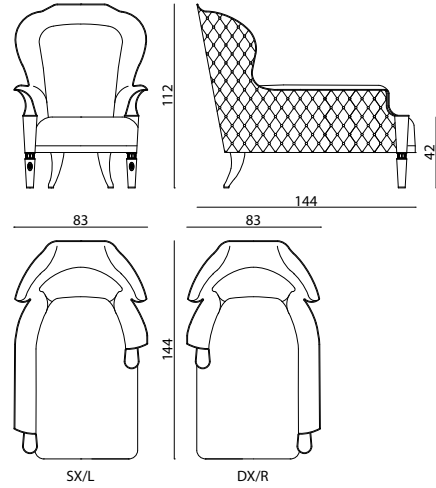

ALICE

CHAISE-LONGUE - CHAISE-LONGUE

Alessandro La Spada

Struttura portante in massello di faggio e compensato. Piano seduta con molleggio a nastri elastici su telaio in faggio. Imbottitura schienale e braccioli in poliuretano espanso. Cuscini seduta in poliuretano espanso a quote differenziate semirigido nella parte inferiore e morbido nella parte superiore. Retroschienale e fianchi con rivestimento accoppiato a falda di fibra acrilica con supporto in vellutino acrilico. Tappezzeria fianchi esterni braccioli e bordo parte alta schienale con bottoni, effetto capitonné. Gambe anteriori e posteriori rivestite in pelle o tessuto. Le gambe anteriori sono decorate con anelli in ottone tornito con incisione motivo Visionnaire.

Main structure in beech solid wood and plywood. Seat provided with sprung system made of elastic belts on beech frame. Padding of the back and arms in polyurethane. Seat cushions in polyurethane in different densities, semirigid in the lower part and soft in the upper part. Cover of rear back and sides coupled to acrylic lining, with support in acrylic velvet. Upholstery of the arms external sides and of the back high border with buttons with capitonné effect. Front and rear legs covered with leather or fabric. The front legs are decorated with rings in turned brass with oval pattern engraving and oval medal in brass, with Visionnaire logo carving.

vedi anche/see also ALICE poltrona-armchair, ALICE panca-bench, ALICE comodino-bedside table, ALICE chest of drawers

[click here](#)

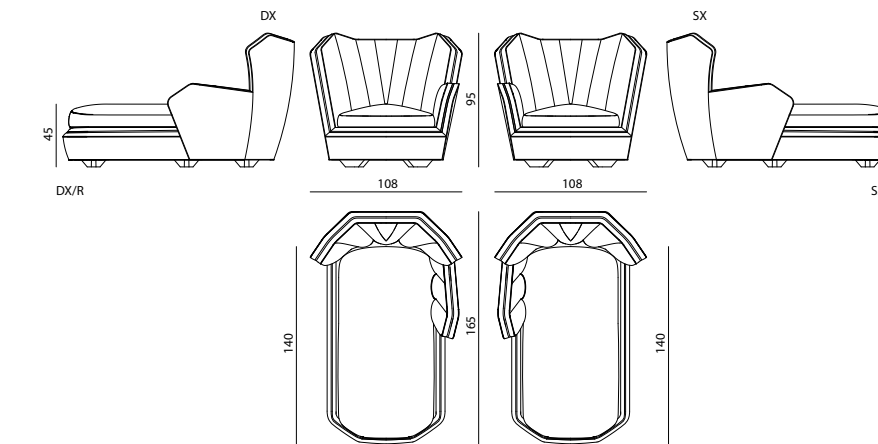
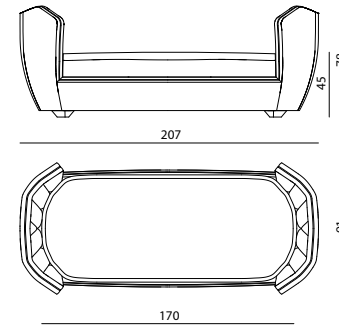

HEMINGWAY

TURCA, CHAISE-LONGUE

OTTOMAN, CHAISE-LONGUE

Samuele Mazza

Struttura interna in legno massello e multistrati di pioppo con molleggio a cinghie elastiche, imbottitura in poliuretano espanso a densità differenziate. Rivestimento in pelle o tessuto. Schienale e braccioli sagomati tappezzati internamente con pannelli imbottiti, rivestiti singolarmente. Cuscini di seduta in poliuretano a densità differenziate, Memory Foam® e piuma d'oca. Basamento, braccioli e schienale sono decorati con una cerniera disponibile in finitura oro, ottone anticato e nickel nero. Piedi in legno di faggio laccato opaco.

Internal structure in solid wood and poplar plywood, equipped with spring system with straps; padding in polyurethane foam in different densities. Upholstery in leather or fabric. Shaped back and armrests internally upholstered with individually padded panels. Seat cushions padded in polyurethane in different densities, Memory Foam® and goose down. Base, armrests and back decorated with zip, available in gold, antiqued brass or black nickel finishing. Feet in matt lacquered beech wood.

vedi anche/see also HEMINGWAY divano, poltrona-sofa, armchair, HEMINGWAY panca-bench, HEMINGWAY letto-bed

[click here](#)

- click on the icons -



ADELE p.108



BASTIAN p.108



BLONDIE p.109



CITIZEN p.109



DOUGLAS p.110



EKOS p.110



GEBO p.111



GRACE p.111



JORGE p.112



KINGS CROSS p.112



LEANDRO p.113



PRINCESS p.113



SONTAG p.114



TITANIA p.114



ULTRASOUND p.115



VANITY FAIR p.115



WICKED p.116

- click on the icons -

ICONICI - *ICONIC*



ALICE p.118



BRADLEY p.118



DAGONET p.119



ERRAKIS p.119



HEMINGWAY p.120



PRISCILLA p.120



SIEGRID CAPITONNÉ p.121



SIEGRID p.121

ADELE

POUF - POUFFE

Marco Piva

Pouf upholstered in leather or fabric, structure in curved plywood and solid wood equipped with elastic spring belts, padding in polyurethane foam with different densities and acrylic fibre. Base in stainless steel available with polished chrome, gold, champagne and satin black nickel finish.

Pouf rivestito in pelle o tessuto, struttura in multistrato curvato e legno massello dotato di cinghie elastiche a molle, imbottitura in poliuretano espanso a quote differenziate e fibra acrilica. Base in acciaio inox disponibile con finitura cromo lucido, oro, champagne e nichel nero satinato.

vedi anche/see also ADELE poltrona-armchair

[● click here](#)

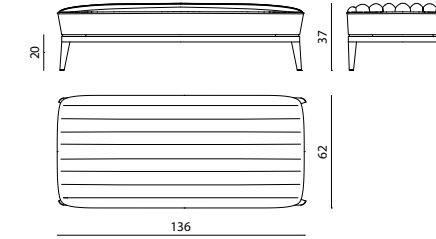
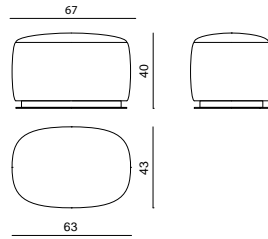

BLONDIE

PANCA - BENCH

La Conca

Struttura in massello e multistrati di pioppo sagomato, imbottitura in poliuretano espanso a densità differenziate e molleggio seduta a cinghie elastiche. Seduta imbottita in Memory Foam® rivestita internamente in pelle o tessuto trapuntato a porzioni singolarmente imbottite. Rivestimento esterno in pelle o tessuto liscio, filetti in pelle. Base e piedi in legno di faggio massello rivestito in essenza con angolari e piedini in acciaio inox satinato. Scocca e piedi sono disponibili nelle finiture selezione essenze; le parti metalliche sono disponibili nella selezione finiture metalliche satinato.

Structure in solid wood and shaped poplar plywood, padding in polyurethane foam with different densities and elastic straps springing system. Seat padded in Memory Foam® internally upholstered in leather or fabric, quilted portions padded one-by-one. External upholstery in leather or smooth fabric, pipings in leather. Base and feet in beech solid wood covered in veneer with corner elements and feet pads in satinized stainless steel. Structure and feet available in the veneer finishing selections; metal parts available in the satinized metal finishing selection.

vedi anche/see also BLONDIE poltrona-armchair

[● click here](#)

BASTIAN

POUF - POUFFE

Mauro Lipparini

Pouf quadrato con struttura interna in legno massello e multistrati di abete, imbottitura in poliuretano a densità differenziate. Rivestimento in pelle o tessuto. Fettucce decorative ribattute in pelle o tessuto. Filetti in pelle. Disponibile anche con fregi sui fianchi in alluminio satinato e interno in acciaio inox satinato a turale, la cornice esterna è disponibile nella selezione finiture metalliche.

Squared pouffe with internal structure in solid wood and fir plywood, padding in polyurethane with different densities. Upholstery in leather or fabric. Decorative inserts with felled seams, made in leather or fabric. Pipings in leather. Option also available: friezes on lateral sides in satinized aluminium and internal plate in satinized stainless steel, the external frame is available in the metal finishing selection.

vedi anche/see also BASTIAN divano - sofa, BASTIAN chaise-longue

[● click here](#)

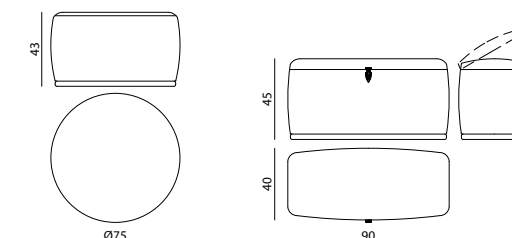
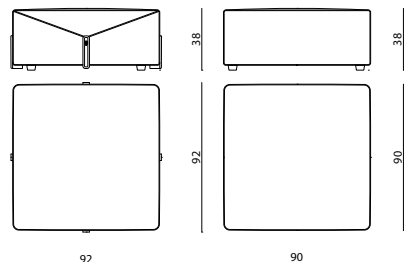

CITIZEN

POUF - POUFFE

Mauro Lipparini

Pouf tondo e rettangolare con struttura interna in legno, imbottitura in poliuretano a densità differenziate. Rivestimento sui fianchi in pelle o tessuto liscio e parte superiore in pelle o tessuto intrecciato. In opzione, nella versione rettangolare, coperchio apribile con vano interno portaoggetti in legno finitura laccata opaca.

Upholstered round and rectangular pouffe, internal structure in wood, padding in polyurethane in different densities. Sides upholstered in leather or smooth fabric and upper part upholstered in leather or interwoven fabric. Optional in the rectangular version, container with opening on an inner storage compartment, finished with matt lacquering.

vedi anche/see also CITIZEN divano, poltrona-sofa, armchair, CITIZEN chaise-longue

[● click here](#)



DOUGLAS

POUF - POUFFE

Alessandro La Spada

Pouf upholstered in leather or fabric. The base is characterised by two curved metal elements working as feet. Frame in wood equipped with elastic spring belts. Seat cushion padded in polyurethane foam with different densities, Memory Foam® and feather. Metal parts can be lacquered in any colour of the polish metal finish selection.

Pouf rivestito in pelle o tessuto. La base è caratterizzata da due elementi in metallo curvato che fungono da piedini. Struttura in legno dotata di cinghie elastiche a molle. Cuscino seduta imbottito in poliuretano espanso a quote differenziate, Memory Foam® e piuma. Le parti metalliche possono essere laccate in qualsiasi colore della selezione di finiture in metallo lucido.

vedi anche/see also DOUGLAS divano, poltrona-sofa-armchair, DOUGLAS tavolino-low table

● [click here](#)

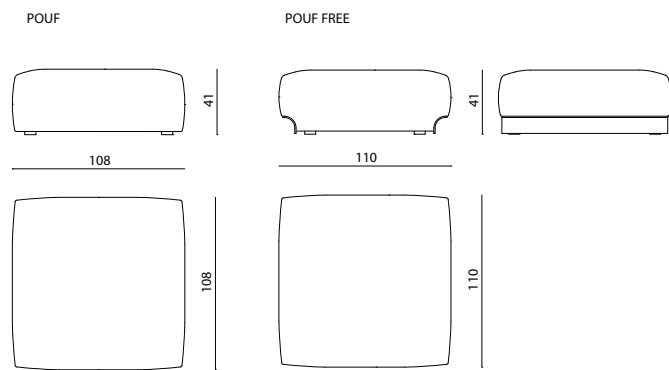

GEBO

POUF - POUFFE

Steve Leung

Scocca posteriore in multistrato curvato laccato lucido, oppure impiallacciato ebano, radica o eucaliptus. Base in alluminio cromato oppure laccato nella selezione finiture metalliche satiniate. Molleggio a cinghie elastiche e imbottitura in poliuretano espanso, Memory Foam® e fibra acrilica.

Curved plywood back structure in glossy lacquered finishing, or in veneered ebony briarwood or eucalyptus wood. Base in aluminium. Sprung system with elastic straps and upholstery in polyurethane foam, Memory Foam® and acrylic fibre. Metal parts available in the metal finishing selection.

● [click here](#)

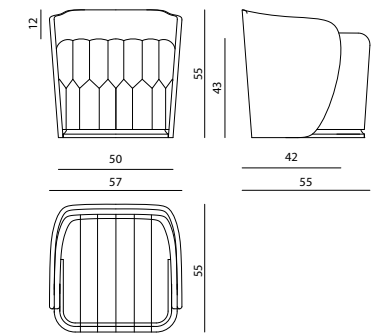

EKOS

PANCA - BENCH

Alessandro La Spada

Panca imbottita con seduta lineare rivestita in pelle o tessuto, basamento rivestito in acciaio inox lucido curvato, con elementi laterali in marmo massello a forma concava. Le parti in acciaio sono disponibili nella selezione finiture metalliche. La seduta è disponibile anche nella versione "quilted" in pelle con ricamo con disegno foliage, leggermente imbottito.

Upholstered bench with linear seat in leather or fabric, base covered in curved polished stainless steel, with concave-shaped solid marble side elements. Metal parts available in the metal finishing selection. The seat is also available in the "quilted" version in leather with embroidery with a slightly padded, foliage design.

vedi anche/see also EKOS consolle-console

● [click here](#)

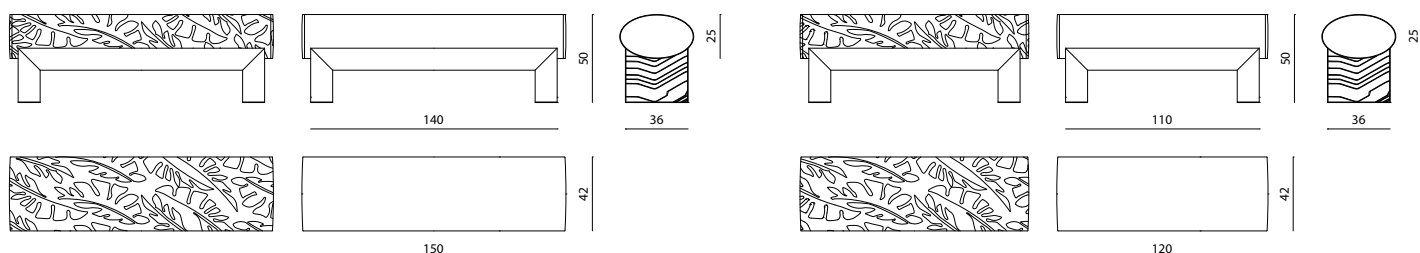

GRACE

POUF - POUFFE

Steve Leung

Pouf imbottito e tappezzato con struttura in legno massello e multistrati di pioppo. Seduta e schienale in poliuretano a densità differenziate. Rivestimento seduta in pelle o tessuto lisci, parte esterna schienale a lavorazione cannettata. Base in acciaio satinato. Le parti metalliche sono disponibili nella selezione finiture metalliche satiniate.

Pouffe padded and upholstered, with structure in solid wood and poplar plywood. Seat and backrest in polyurethane with different densities. Seat upholstery with quilted cannetté decoration. Base in satinized steel. Metal parts available in the satinized metal finishing selection.

vedi anche/see also GRACE poltrona-armchair

● [click here](#)

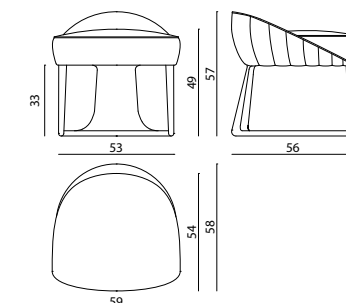

JORGE

POUF - POUFFE

La Conca

Cassapanca imbottita rivestita in pelle o tessuto, con sedile apribile disponibile in pelle o tessuto intrecciato. Fusto interno in legno, base e profilo sedile in acciaio inox satinato. Vano interno in legno laccato. Le parti metalliche sono disponibili nella selezione finiture metalliche.

Upholstered chest covered in leather or fabric, with opening seat available in leather or woven fabric. Internal wooden frame, base and seat profile in brushed stainless steel. Internal compartment in lacquered wood. Metal parts available in the metal finishing selection.

● [click here](#)

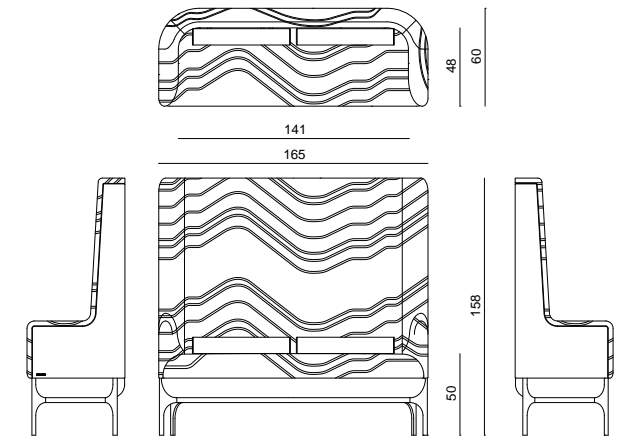
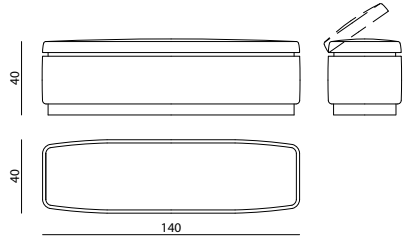

LEANDRO

PANCA ALTA - HIGH BENCH

Alessandro La Spada

Struttura portante in legno massello e multistrati. Piano seduta con molleggio a nastri elastici. Imbottitura di seduta e schienale in poliuretano a densità differenziate, rivestimento interno di seduta e schienale decorato con disegno trapuntato a ricamo. Piedi anteriori e posteriori in acciaio curvato a finitura lucida e fasce decorative. Le parti metalliche sono disponibili nella selezione finiture metalliche lucide.

Main structure in solid wood and plywood. Seat equipped with elastic spring belts. Padding of seat and backrest in polyurethane foam with different densities. Internal seat and backrest upholstery decorated with quilted motif. Front and rear feet in curved steel with polish finish and decorative bands. Metal parts can be lacquered in any colour included in the polished metal finish selection.

● [click here](#)



KINGS CROSS

POUF - POUFFE

Mauro Lipparini

Sgabello/pouf, struttura portante in legno massello di noce canaletto con finitura naturale a poro aperto, scolpito con sezione sagomata a tre lobi, seduta imbottita in poliuretano e tappezzata in pelle o tessuto.

Stool/pouffe. Main frame in Canaletto walnut solid wood with open-pore natural finish and shaped three-lobes section. Seat with polyurethane padding and upholstery in leather or fabric.

vedi anche/see also KINGS CROSS tavolo basso-low table, KINGS CROSS consolle-console, KINGS CROSS mobile basso-low cabinet, KINGS CROSS cassettera-chest of drawers, KINGS CROSS mobile bar-bar cabinet, KINGS CROSS mobile trucco-make-up unit

● [click here](#)

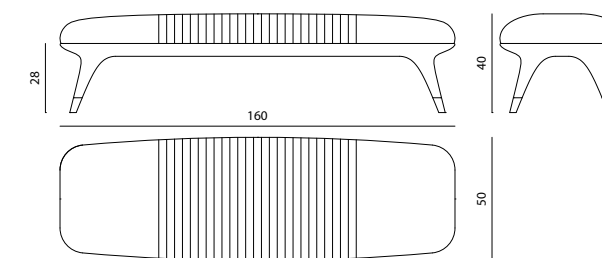
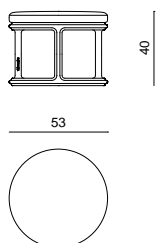

PRINCESS

PANCA - BENCH

Steve Leung

Panca tappezzata in pelle o tessuto. Struttura in legno massello scolpito e rivestito in pelle con piedi sagomati conici con puntale metallico satinato. Piano seduta con parte centrale in pelle con lavorazione a plissettature ribattute e parti laterali in pelle o tessuto. Le pelli disponibili sono: Nabuk, Soft leather, Malta, Sherwood, Classic. Le parti metalliche sono disponibili nella selezione finiture metalliche satinato.

Bench upholstered in leather or fabric. Structure in solid wood carved and upholstered in leather with conic-shaped feet with satinized metal tips. Seat with central part in leather decorated with pleated motive and lateral parts in leather or fabric. Leathers available: Nabuk, Soft, Malta, Sherwood, Classic. Satinized metal parts available in the metal finishing selection.

vedi anche/see also PRINCESS letto-bed

● [click here](#)



SONTAG

POUF - POUFFE

Samuele Mazza

Struttura in multistrati sfaccettata "a diamante", imbottitura di poliuretano espanso e falda acrilica. Base sfaccettata girevole in acciaio inox lucidato disponibile nella selezione finiture metalliche.

"Diamond" shaped structure in plywood, padding in polyurethane foam and acrylic fibre. Multi-faceted base in polished stainless steel available in the metal finishing selection.

vedi anche/see also SONTAG poltrona-armchair

● [click here](#)

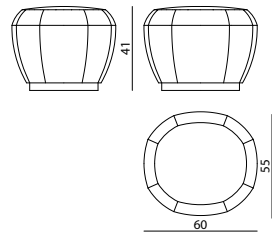

ULTRASOUND

POUF - POUFFE

Alessandro La Spada

Pouf tappezzato in pelle o tessuto. Scocca in legno multistrati curvato imbottito a fasce diagonali singolarmente tappezzate, sedile in poliuretano, zoccolo di base in acciaio lucidato disponibile nella selezione finiture metalliche.

Pouf upholstered in leather or fabric. Frame made of curved multilayer wood upholstered in individually upholstered diagonal strips, seat in polyurethane, base in polished steel available in a selection of metal finishes.

● [click here](#)

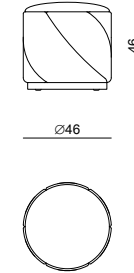

TITANIA

POUF - POUFFE

Alessandro La Spada

Struttura portante in compensati di multistrati di pioppo con imbottitura di seduta in poliuretano espanso. Fascia e zoccolo in lamina d'acciaio disponibili nella selezione finiture metalliche.

Main structure in poplar plywood with seat padding in polyurethane. Band and plinth in steel laminate, available in the metal finishing selection.

● [click here](#)

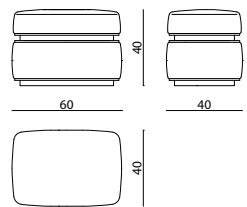

VANITY FAIR

POUF - POUFFE

Giuseppe Viganò

Struttura portante sagomata in ferro smaltato e maglia metallica, imbottita in poliuretano espanso, molleggio seduta a cinghie elastiche. Rivestimento della scocca in pelle o tessuto e cover reversibile double face, con leggera trapuntatura in piuma d'oca e sistema di chiusura con alamari nascosti. Gambe in ferro conificato smaltato ed elementi di finitura in alluminio tornito e cromato. La pelliccia è disponibile in finitura naturale su base grigia o marrone, o tinta tortora, le parti metalliche sono disponibili nella selezione finiture metalliche.

Main structure in moulded enamelled iron and metallic mail padded in expanded polyurethane. Seat spring system with elastic belts. Body upholstery in leather or fabric not removable. Reversible cover double face, lightly quilted with goose down and closed by hidden frog. Legs in enamelled iron with conic shape. Finishing elements in turned and chromed aluminium. The fur coating is available in natural finishing on a gray or brown base or in dove-gray colour, metal parts available in the metal finishing selection.

vedi anche/see also VANITY FAIR divano, poltrona-sofa, armchair, VANITY FAIR chaise-longue

● [click here](#)

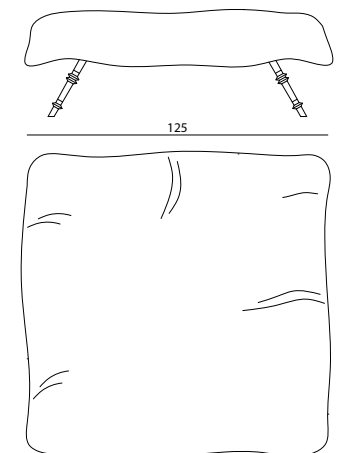

WICKED

POUF - POUFFE

Alessandro La Spada

Pouf tappezzato con trama geometrica. Struttura in multistrati, imbottitura della seduta in poliuretano e Memory Foam®. Fianchi e retro tappezzati con pannelli leggermente imbottiti rivestiti singolarmente in pelle o tessuto. Basamento e inserto in acciaio inox satinato con logo inciso, disponibile nella selezione finiture metalliche satiniate.

Upholstered pouffe with geometrical pattern. Structure in plywood, seat padded in polyurethane and Memory Foam®. Sides and back with slightly padded panels, individually upholstered in leather or fabric. Base and insert in stainless steel with engraved logo, also available in the satinized metal finishing selection.

● [click here](#)

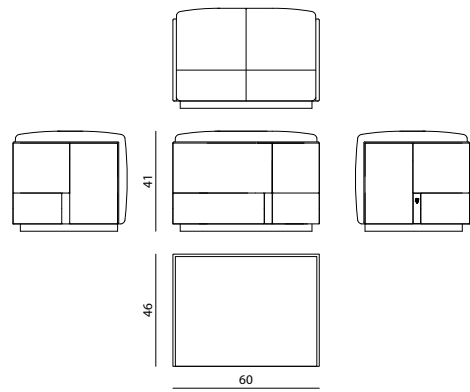



ALICE

PANCA SINGOLA, DOPPIA

SINGLE, DOUBLE BENCH

Alessandro La Spada

Struttura portante in massello di faggio e compensato. Piano seduta con molleggio a nastri elastici su telaio in faggio. Imbottitura schienale in poliuretano espanso. Braccioli in poliuretano espanso.

Cuscini seduta in poliuretano espanso a quote differenziate, semi-rigido nella parte inferiore e morbido nella parte superiore. Retro-schienale e fianchi con rivestimento accoppiato a falda di fibra acrilica da con supporto in vellutino acrilico. Tappezzeria fianchi esterni braccioli e bordo parte alta schienale con bottoni, effetto capitonné. Gambe anteriori e posteriori rivestite in pelle. Le gambe anteriori sono decorate con anelli in ottone tornito con incisione motivo ovali e medaglione ovale in ottone, con incisione logo Visionnaire.

Main structure in beech solid wood and plywood. Seat provided with sprung system made of elastic belts on beech frame. Padding of the back in polyurethane. Arms in polyurethane. Seat cushions in polyurethane in different densities, semirigid in the lower part and soft in the upper part. Cover of rear back and sides coupled to acrylic lining, with support in acrylic velvet. Upholstery of the arms external sides and of the back high border with buttons with capitonné effect. Front and rear legs covered with leather. The front legs are decorated with rings in turned brass with oval pattern engraving and oval medal in brass, with Visionnaire logo carving.

vedi anche/see also ALICE poltrona-armchair, ALICE chaise-longue, ALICE comodino-bedside table, ALICE cassettiera-chest of drawers

● [click here](#)

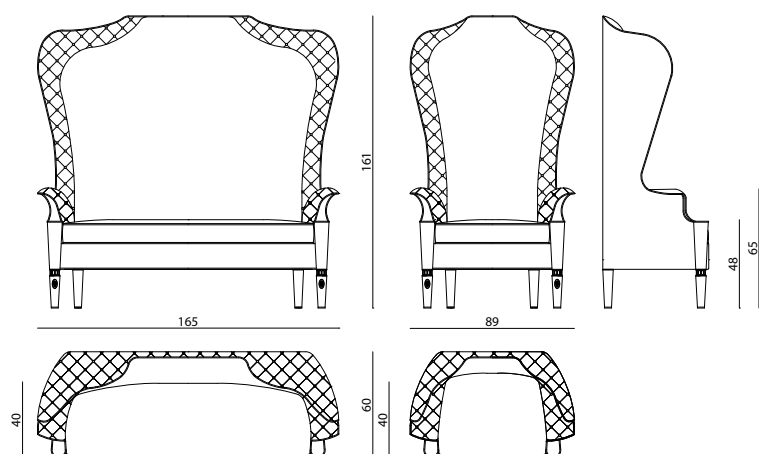

DAGONET

PANCA - BENCH

Alessandro La Spada - Samuele Mazza

Telaio in acciaio cromato. Piedi in alluminio tornito finitura cromo. Imbottitura in poliuretano espanso a quote differenziate, montata su telaio in massello di abete con piano di seduta in multistrati di pino. Tappezzeria a losanghe, capitonné. Non sfoderabile.

Frame in chromed steel. Feet in chrome finished lathed aluminium. Padding in polyurethane at different densities, put on a frame in fir wood with seat support in plywood pinewood. Lozenge upholstery capitonné. Non-removable upholstery.

vedi anche/see also DAGONET piantana-floor lamp

● [click here](#)

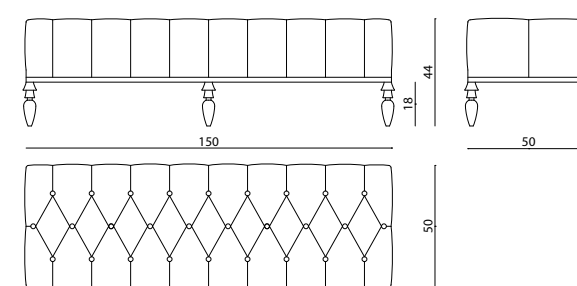

BRADLEY

TURCA - OTTOMANE

Giuseppe Viganò

Struttura in multistrati imbottita in poliuretano e rivestita in pelle o tessuto, cuscino di seduta e cuscini a rullo in poliuretano e piuma d'oca. Profili in acciaio inox lucido oppure disponibili nella selezione finiture metalliche.

Structure in plywood padded with polyurethane and upholstered in leather or fabric, seat cushion and roll cushions in polyurethane and goose down. Profiles in polished stainless steel or available in the metal finishing selection.

vedi anche/see also BRADLEY letto-bed, BRADLEY comodino-bedside table

● [click here](#)

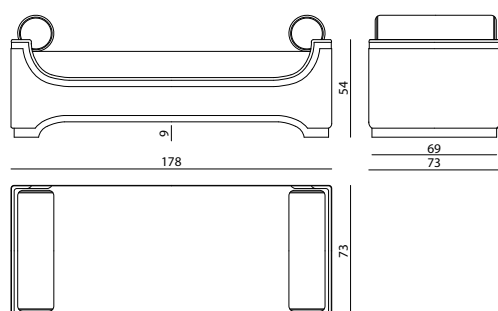

ERRAKIS

POGGIAPIEDI - FOOTSTOOL

Samuele Mazza

Struttura in legno compensato multistrati. Imbottitura in poliuretano espanso con foderatura in falda resinata. Rivestimento capitonné non sfoderabile. Piedi in alluminio tornito, finitura cromo.

Structure in multiply plywood. Filling in polyurethane with lining in resinated layer. Cover capitonné not removable. Feet in curved aluminium, chrome finishing.

● [click here](#)

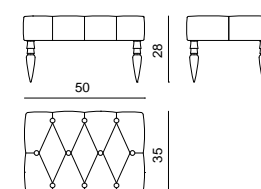



HEMINGWAY

PANCA ALTA - HIGH BENCH

Samuele Mazza

Struttura interna in legno massello e multistrati con molleggio a cinghie elastiche, imbottitura in poliuretano espanso a densità differenziate. Schienale e braccioli sagomati tappezzati internamente con pannelli imbottiti, rivestimento in pelle o tessuto. Cuscini di seduta in poliuretano a densità differenziate. Basamento, braccioli e schienale sono decorati con una cerniera, disponibile in finitura oro, ottone anticato e nickel nero. Piedi in legno di faggio laccato opaco.

Internal structure in solid wood and plywood, spring system with straps, padding in polyurethane foam in different densities. Shaped back and armrests internally upholstered with padded panels. Upholstery in leather or fabric. Seat cushions in polyurethane in different densities. Base, armrests and backrest decorated with a zipper available in gold, antiqued brass or black nickel finishing. Feet in matt lacquered beech wood.

vedi anche/see also HEMINGWAY divano, poltrona-armchair, sofa, HEMINGWAY panca-ottoman, HEMINGWAY letto-bed

[click here](#)

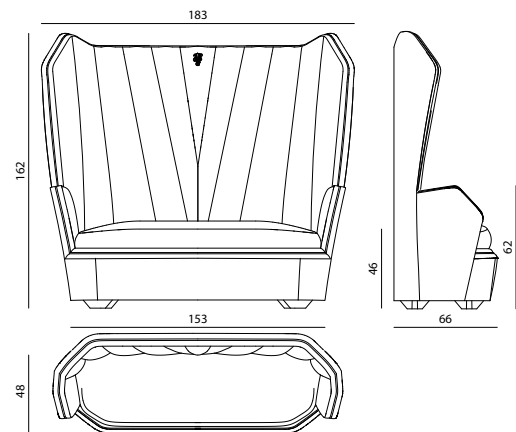

SIEGFRID CAPITONNÉ

PANCA ALTA - HIGH BENCH

Alessandro La Spada - Samuele Mazza

Struttura portante in legno massello d'abete, con molleggio bracciolo a cinghie elastiche. Imbottitura in poliuretano espanso a quote differenziate. Piano di seduta rigido con cuscino in poliuretano espanso ad alta densità con foderatura in vellutino acrilico accoppiato a falda acrilica. Piedi anteriori in alluminio tornito e cromato oppure laccati oro/bronzo. Piedi posteriori rivestiti in pelle, stesso colore delle nappe applicate ai braccioli. Rivestimento della struttura non sfoderabile. Rivestimento cuscino seduta, sfoderabile. Disponibile anche nella versione con schienale "capitonné".

Main frame in fir solid wood, with sprung system for arm made of elastic belts. Padding in expanded polyurethane of different densities. Rigid seat base, with cushion in high density expanded polyurethane and acrylic lining coupled with acrylic fibre layer. Front feet in turned and chromed aluminium or gold/bronze lacquered. Back feet covered in leather, same colour of the tassels on the front of the arms. Cover of the structure not removable. Cover of the seat cushion removable. Also available with "capitonné" back.

vedi anche/see also SIEGFRID sedia-chair

[click here](#)

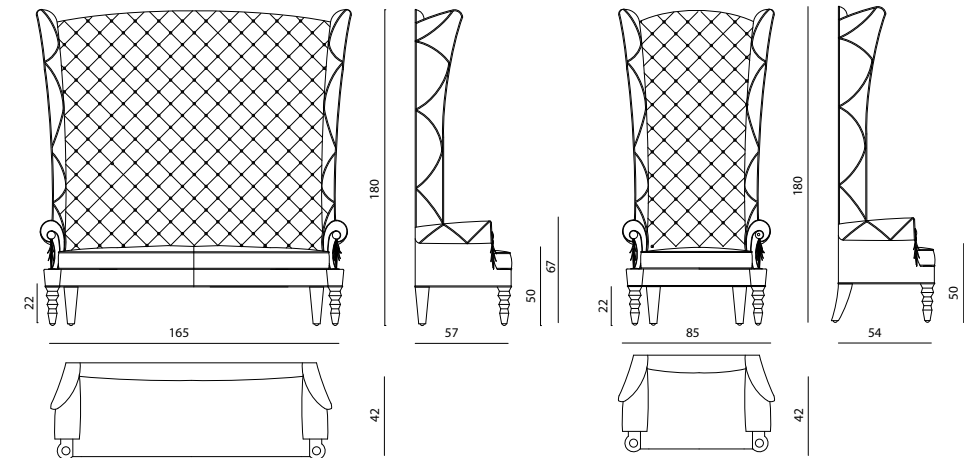

PRISCILLA

DIVANETTO - SOFA

Alessandro La Spada

Divanetto rivestito in pelle o tessuto, struttura portante in faggio massiccio laccato lucido. Elementi decorativi in alluminio e acciaio cromati sulle gambe. Sostegno schienale formato da due elementi cromati in alluminio e acciaio. Schienale in multistrati curvato con imbottitura in poliuretano; cuscino di seduta con molleggio a cinghie elastiche e imbottitura in poliuretano ad alta densità, le parti metalliche sono disponibili nella selezione finiture metalliche.

Sofa upholstered in leather or fabric. Supporting structure in solid beech wood glossy lacquered. Aluminium and chromed steel decorative elements applied on the legs. Two aluminium and chromed steel elements are fixed in backrest support which is made of curved multi plywood and padded with polyurethane. Seat cushion with elastic belts system and padded in high density polyurethane, metal parts available in the metal finishing selection.

vedi anche/see also PRISCILLA sedia-chair

[click here](#)

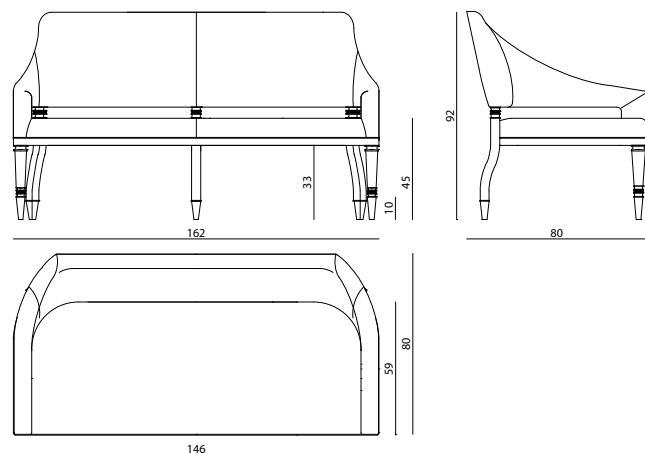

SIEGFRID

PANCA ALTA - HIGH BENCH

Alessandro La Spada - Samuele Mazza

Struttura portante in legno massello d'abete, con molleggio bracciolo a cinghie elastiche. Imbottitura in poliuretano espanso a quote differenziate. Piano di seduta rigido con cuscino in poliuretano espanso ad alta densità con foderatura in vellutino acrilico accoppiato a falda acrilica. Piedi anteriori in alluminio tornito e cromato oppure laccati oro/bronzo. Piedi posteriori rivestiti in pelle, stesso colore delle nappe applicate ai braccioli. Rivestimento della struttura non sfoderabile. Rivestimento cuscino seduta, sfoderabile. Disponibile anche nella versione con schienale "capitonné".

Main frame in fir solid wood, with sprung system for arm made of elastic belts. Padding in expanded polyurethane of different densities. Rigid seat base, with cushion in high density expanded polyurethane and acrylic lining coupled with acrylic fibre layer. Front feet in turned and chromed aluminium or gold/bronze lacquered. Back feet covered in leather, same colour of the tassels on the front of the arms. Cover of the structure not removable. Cover of the seat cushion removable. Also available with "capitonné" back.

vedi anche/see also SIEGFRID sedia-chair

[click here](#)

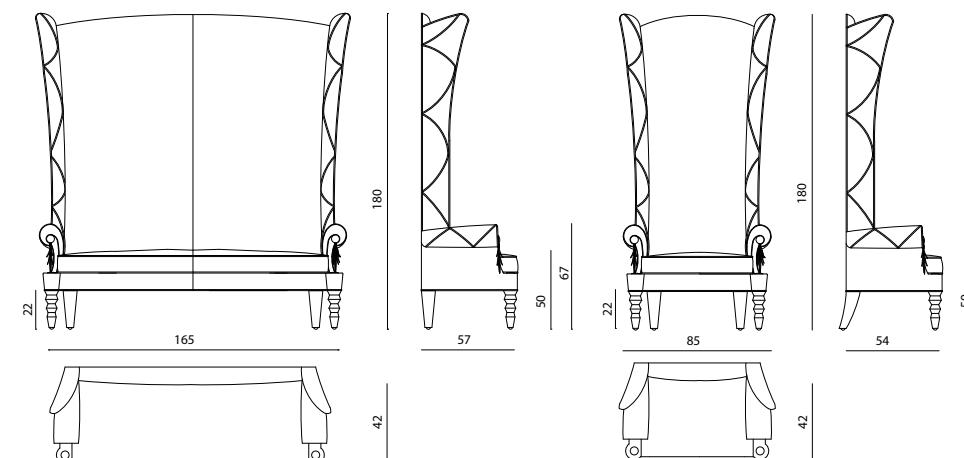

- click on the icons -



ALBATROS p.126



ALEKSANDRA p.126



AMINTA p.127



ANASTASIA p.127



ASHA p.128



ASTRID p.128



BONNIE p.129



CABIRIA p.129



CLOUD p.130



CARMEN PADDED p.130



CARMEN STEEL p.131



CLEM p.131



CLEM p.132



ELEANOR p.132



GASPARD p.133



GINSBERG p.133



GINSBERG p.134



JERA p.134

- click on the icons -



KYLO FRAMED p.135



KYLO PADDED p.135



KYLO p.136



NANOOK p.136



PALMYRA p.137



PLANET p.137



RHEA p.138



SADKO p.138



SEKTOR p.139



STONE p.139



SUNNY p.140



SUNNY p.140



SYBILLA p.141



TANYA p.141



VOLVER p.142



ZOE DECO p.142

- click on the icons -

ICONICI - *ICONIC*



BOVERY p.144



GRIMILDE p.144



MAC KENZIE p.145



PRISCILLA p.145



SÉVIGNÉ p.146



SÉVIGNÉ OFFICE p.146



SIEGFRID p.147



SIEGFRID p.147



YORK p.148

ART DESIGN



ASTRID p.652

SEDIE, SGABELLI, SEDIE DA UFFICIO -
CHAIRS, STOOLS, OFFICE CHAIRS



ALBATROS

SGABELLO - STOOL

Alessandro La Spada

Sgabello con schienale, monoscocca in legno multistrati curvato, con gambe in tubo metallico di acciaio inox. Rivestimento in pelle o tessuto con filetti sui bordi. Le parti in metallo sono disponibili nella selezione finiture metalliche.

Stool with small backrest, whole structure in curved plywood, with legs in stainless steel tube. Upholstery in leather or fabric and matching pipings on the edges. Metal parts can be lacquered in any colour included in the metal finish selection.

vedi anche/see also ALBATROS dehors

● click here

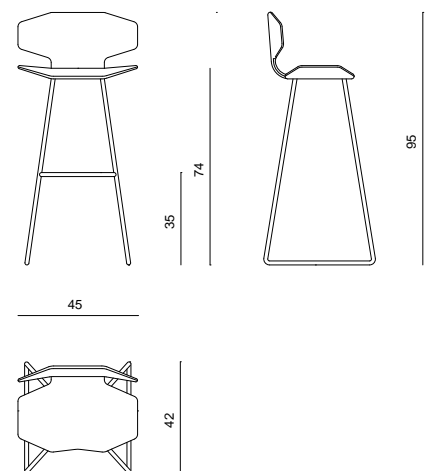

ALEKSANDRA

SEDIA - CHAIR

Alessandro La Spada

Struttura in legno massello sagomato e laccato lucido (colori RAL). Schienale in compensato curvato e tappezzato. Sedile in legno imbottito e trapuntato. Puntali e traversi in alluminio tornito e Logo sui braccioli finitura cromo oppure oro, bronzo o nichel nero.

Structure in solid shaped and lacquered polish wood (RAL colours). Backrest in curved upholstered plywood. Seat in padded wood and quilted. Turned aluminium nails and crossbars, and chromed engraved logo in the armrest in gold, bronze or black nickel.

● click here

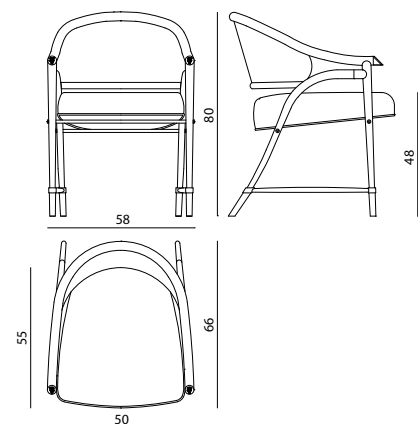

AMINTA

SEDIA - CHAIR

Giuseppe Viganò

Sedia in acciaio inox con seduta e schienale tappezzati in pelle o tessuto. Gambe in tubo conificato lucido e schienale con telaio rivestito da una copertina removibile tappezzata assicurata al telaio. Sedile dotato di cinghie elastiche tappezzato e imbottito in poliuretano. Il telaio è disponibile nella selezione finiture metalliche.

Chair in stainless steel with upholstered seat and back in leather or fabric. Legs in polished tubular steel with conic section and backrest with frame covered with a thin lining. The cover attached at the frame can be easily removed. Seat equipped with elastic spring belts, padded in polyurethane. The frame can be lacquered in any colour included in the metal finish selection.

vedi anche/see also AMINTA dehors

● click here

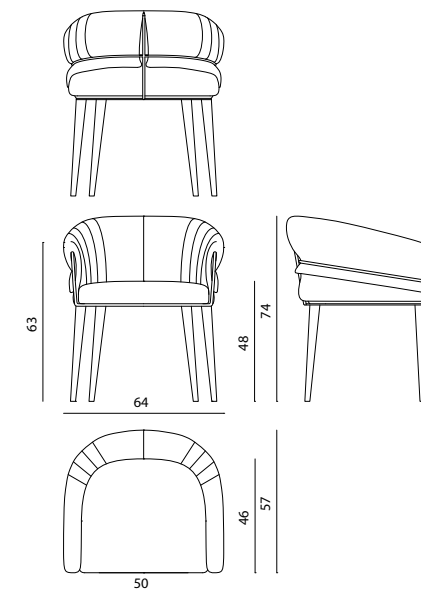

ANASTASIA

POLTRONA, POLTRONCINA, SEDIA - ARMCHAIR, CHAIR

Roberto Tapinassi, Maurizio Manzoni

Interamente in cuoio spessore 3 mm con inserti spalliera intagliati con motivo gessato. Struttura interna in metallo.

Entirely in 3mm thick leather with carved espalier inserts with a pinstripe pattern. Internal metal structure.

● click here

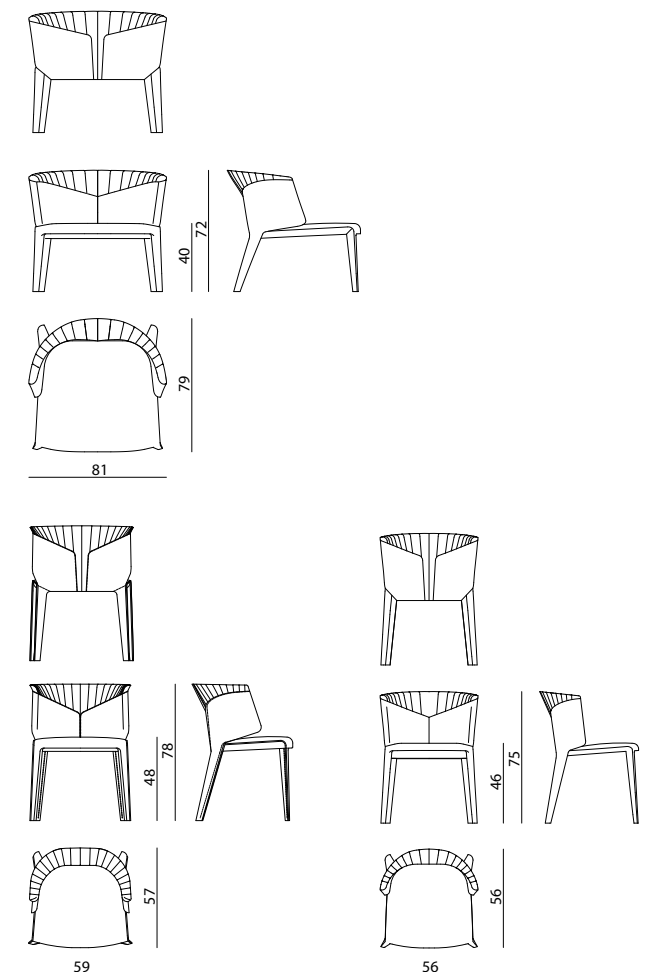



ASHA

SEDIA - CHAIR
Steve Leung

Scocca in multistrati curvato rivestita all'esterno in pelle o tessuto, imbottita all'interno in poliuretano e tappezzata in pelle o tessuto, esterno schienale con lavorazione trapuntata a rombi. Sedile con molleggio a cinghie elastiche imbottito in poliuretano. Gambe e cornice in legno massello di frassino scolpito tinto opaco, disponibili in opzione tinto lucido 100 gloss o verniciata a tinte lucide RAL/NCS. Puntali in metallo disponibili nella selezione finiture metalliche.

Frame in curved multiply wood, externally upholstered in leather or fabric, padded inside in polyurethane and covered in leather or fabric, rearback with rhombuses quilting. Seat with elastic strip springing padded with polyurethane. Legs and frame in carved solid ash wood with mat finish or available in glossy stained or painted in glossy RAL/NCS colours. Metal tips available in the metal finishes selection.

● click here

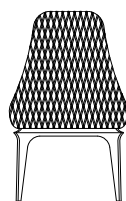

45

54

89

56

41



ASTRID

SEDIA - CHAIR
Alessandro La Spada

Sedia imbottita con scocca in legno curvato imbottita e rivestita in pelle o tessuto. Gambe in fusione di alluminio satinato disponibile nella selezione finiture metalliche. Lo schienale è disponibile anche nella versione "quilted" in pelle con ricamo con disegno foliage, leggermente imbottito.

Padded chair with curved wood shell upholstered and covered in leather or fabric. Legs in aluminum cast available in the metal finishing selection. The back is also available in the "quilted" version in leather with embroidery with a slightly padded, foliage design.

vedi anche/see also ASTRID dehors

● click here

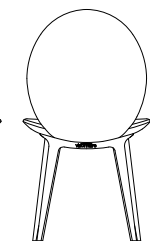
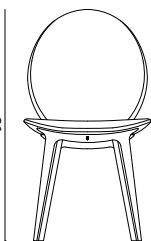
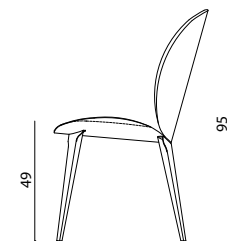

49

95

63

52



BONNIE

SEDIA - CHAIR
La Conca

Sedia imbottita, scocca interna in multistrati di legno curvato, imbottita in poliuretano, con rivestimento in pelle o tessuto a due toni, con filetti a contrasto. Telaio in tubo di acciaio curvato disponibile nella selezione finiture metalliche satinato.

Padded seat, internal frame in curved plywood, padding in polyurethane foam, with dualtone upholstery in leather or fabric, with contrasting piping. Frame in tubular curved steel available with satin metal lacquered finish.

● click here

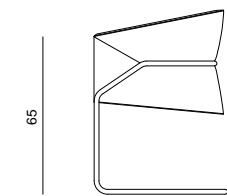

65

43

76

33

39

48

58

55

38

48

44



CABIRIA

SEDIA, SEDIA CON BRACCIOLI - CHAIR, CHAIR WITH ARMRESTS
Marco Piva

Sedia tappezzata con struttura in legno massello e pannelli in multistrato curvato. Scocca esterna dello schienale e gambe posteriori rivestiti in pelle, gambe anteriori in acciaio inox. Seduta e schienale imbottiti in poliuretano a diverse densità e cinghiera elastica per il molleggio del sedile. Disponibile in versione con braccioli. Rivestimento interno schienale e sedile in pelle o tessuto. Le gambe sono disponibili nella selezione finiture metalliche.

Seat with structure in solid wood and shaped plywood panels. Rear backand rear legs upholstered in leather, front legs in stainless steel. Seat andback padded in polyurethane with different densities and elastic beltspring system. Internally upholstered in leather or fabric. Available chair with armrests version. Legs can be finished with any lacquer of the metal lacquer finish selection.

● click here

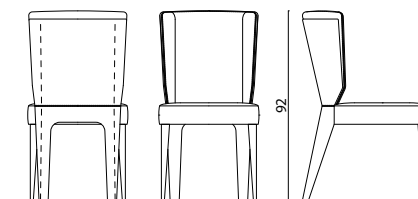

49

47

62

48

48

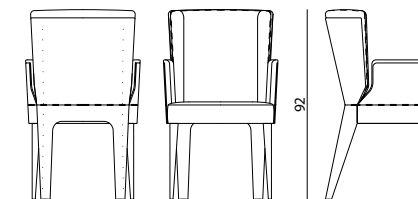

56

47

62

48





CLOUD

SEDIA, SGABELLO - CHAIR, STOOL
Alessandro La Spada

Sedia e sgabello con telaio in acciaio e alluminio cromato a sezione rettangolare con elemento superiore torchon. Struttura di seduta e schienale in legno multistrato curvato, imbottito in poliuretano a densità differenziate e falda acrilica. Rivestimento in pelle o tessuto con schienale decorato con disegno trapuntato. Le parti metalliche sono disponibili nella selezione finiture metalliche.

La sedia è disponibile nella versione CLOUD RADICA con scocca esterna in radica con finitura lucida 100 gloss.

Chair and stool with frame in steel and chromed aluminium with rectangular section and rear-back decorated with torchon element. Seat and back structure in curved plywood, padded in polyurethane foam with different densities and acrylic fibre. Upholstery in leather or fabric with quilted decorative motif on the backrest. Metal parts can be lacquered in any colour included in the metal finish selection.

The chair is available in the CLOUD RADICA version with an external shell in briarwood with a 100 gloss finish.

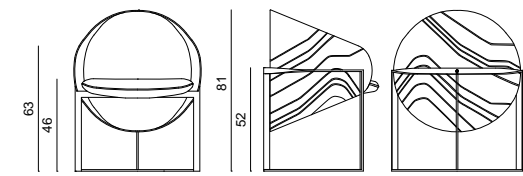

● click here

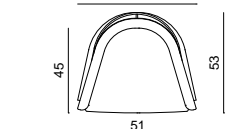
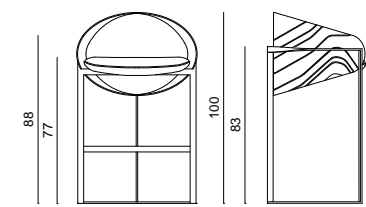
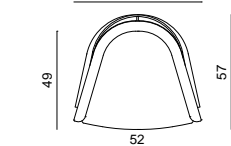

VERSIONE RADICA/ RADICA VERSION

CARMEN PADDED

SEDIA - CHAIR
Alessandro La Spada

Struttura in multistrato curvo di pioppo con lavorazione posteriore "a spacco" e inserto metallico satinato, sedile in multistrato cinghiato con nastri elastici 60 mm incrociati. Imbottitura sedile in poliuretano e lastra di Memory Foam®. Imbottitura schienale in poliuretano a densità differenziata. Rivestimento interno in pelle o tessuto lisci. Rivestimento esterno in pelle o tessuto trapuntato con lavorazione "cannettè". Le parti metalliche sono disponibili nella selezione finiture metalliche satinat.

Structure in curved poplar plywood with decorative "split" on the back and insert in satinized steel, seat in plywood with interwoven elastic straps 60 mm. Backrest padding in polyurethane with different densities. Internal upholstery in leather or fabric quilted with cannettè. Metal parts available in the satinized metal finishing selection.

● click here

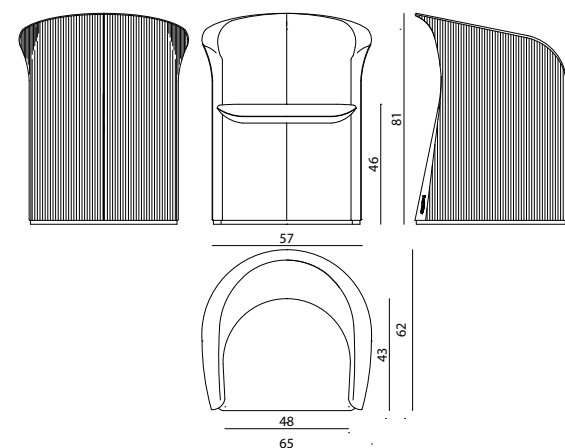

CARMEN STEEL

SEDIA - CHAIR
Alessandro La Spada

Struttura schienale in multistrato curvo di pioppo, base tubolare in acciaio satinato sagomato e curvato, sedile in multistrato cinghiato con nastri elastici 60 mm incrociati. Imbottitura sedile in poliuretano e lastra di Memory Foam®. Imbottitura schienale in poliuretano a densità differenziata. Rivestimento interno in pelle o tessuto lisci. Rivestimento esterno trapuntato con lavorazione disegno "cannettè". Le parti metalliche sono disponibili nella selezione finiture metalliche satinat.

Rearback structure in curved poplar plywood, tubular base in satinized steel, shaped and curved, seat in plywood with interwoven elastic straps 60 mm. Seat padding in polyurethane and layer in Memory Foam. Rear-back padding in polyurethane with different densities. Internal upholstery in leather or fabric. External upholstery quilted with cannettè decorative motive. Metal parts available in the satinized metal finishing selection.

● click here

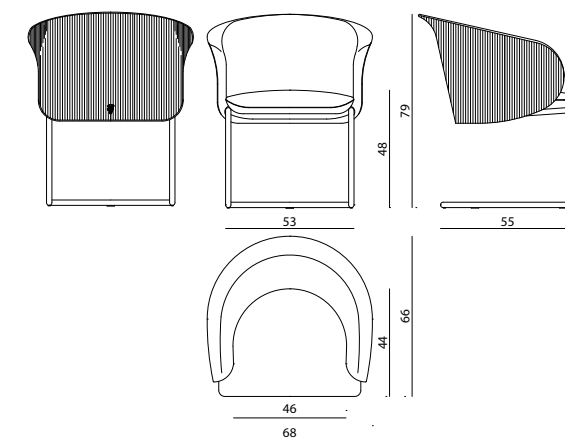

CLEM

SEDIA - CHAIR
Alessandro La Spada

Telaio in tubo di ottone cromato a sezione quadra con logo Visionnaire inciso, struttura di seduta e schienale in legno multistrato curvato, imbottito in poliuretano a densità differenziate e falda acrilica. Rivestimento fisso in pelle o tessuto. Le parti metalliche sono disponibili nella selezione finiture metalliche satinat.

Frame in squared brass pipe with engraved Visionnaire logo, seat structure and backrest in curved plywood padded in polyurethane in different densities and acrylic fibre. Fixed upholstery in leather or fabric. Metal parts available in the satinized metal finishing selection.

vedi anche/see also CLEM dehors

● click here

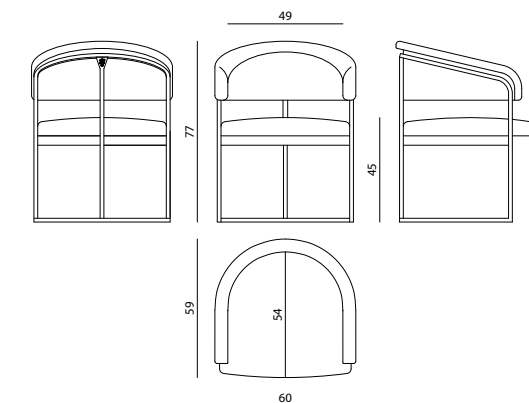



CLEM

SGABELLO - STOOL
Alessandro La Spada

Telaio in tubo di ottone cromato a sezione quadra con logo Visionnaire inciso, poggiatesta in acciaio inox, struttura di seduta e schienale in legno multistrato curvato, imbottito in poliuretano a densità differenziate e falda acrilica. Rivestimento fisso in pelle o tessuto. Le parti metalliche sono disponibili nella selezione finiture metalliche satinato.

Frame in squared brass pipe with engraved Visionnaire logo, footrest in stainless steel, seat structure and backrest in curved plywood padded in polyurethane in different densities and acrylic fibre. Fixed upholstery in leather or fabric. Metal parts available in the satinized metal finishing selection.

vedi anche/see also CLEM dehors

● [click here](#)

ELEANOR

SEDIA - CHAIR
Giuseppe Viganò

Sedia in tubo metallico lucido di Ø16 mm curvato e saldato in unico pezzo, seduta e schienale imbottiti con anima in legno curvato e poliuretano incastonati nel telaio metallico rivestiti in pelle o tessuto. Il telaio è disponibile nelle finiture metalliche lucide.

Chair in shiny tubular metal - Ø16 mm - curved and welded in one piece. Padded seat and backrest with structure in curved wood and polyurethane, surrounded by tubular metal frame and upholstered in leather or fabric. The frame can be finished with any lacquer of the shiny metal lacquer finish selection.

vedi anche/see also ELEANOR dehors

● [click here](#)

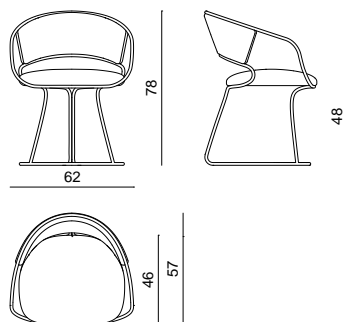

GASPARD

SGABELLO - STOOL
Alessandro La Spada

Struttura schienale in multistrato curvo di pioppo di 18 mm. Imbottitura sedile in densità 45 kg/m³ portante, il tutto ricoperto con lastra di Memory Foam® di 2 cm. Imbottitura spalliera in densità 40 kg/m³ portante. Struttura di base in acciaio inox lucido con logo in ottone e zavorra in ferro, gamba in torneria di alluminio e acciaio cromato con pistone a gas ammortizzato. Poggiatesta in acciaio inox con battitacco satinato, gancio porta borsa in alluminio con logo inciso, disponibile nelle finiture cromo e lacca oro. Disponibile nella versione regolabile in altezza (h seduta variabile da 58 a 82 cm).

Back structure in curved poplar plywood 18 mm. Seat padding D. 45 kg/m³, all covered with a layer of Memory Foam® by 2 cm. Back padding D. 40 kg/m³. Base in polished stainless steel with logo in brass and stabilizing mass in iron, turned leg in aluminium and chromed steel with gas pneumatic cylinder. Footrest in stainless steel with satinized steel bar, bag holder in aluminium with Visionnaire logo engraved, available in the version with chrome finishing or golden lacquer. Available also in the version adjustable in height (seat height from 58 cm up to 82 cm).

● [click here](#)

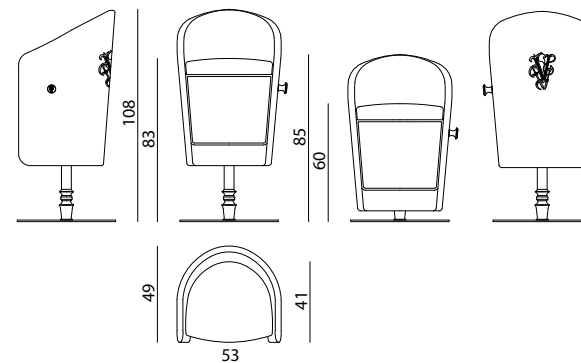
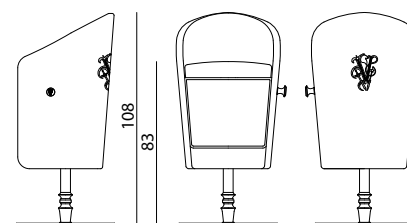

GINSBERG

SEDIA, SEDIA CAPOTAVOLA - CHAIR, HEAD OF THE TABLE CHAIR
Samuele Mazza

Telaio schienale in multistrati sagomato, accorpato al telaio di seduta con gambe in massello di faggio. Molleggio seduta con nastri elastici intrecciati. Rivestimento in pelle o tessuto. Imbottitura piano seduta in poliuretano. Parte interna schienale in poliuretano e falda acrilica con porzioni singolarmente imbottite. Parte esterna in lastra da 10 mm in poliuretano. Gambe in legno di faggio laccate lucido con inserto verticale in metallo lucido da 5 mm disponibile in finitura cromo o oro. Disponibile anche in versione capotavola con braccioli. Disponibile anche in versione con base in acciaio inox a 5 razze lavorato al laser da sp. 8 mm lucidato, con rotelle e torneria in alluminio regolabile in altezza disponibile nella selezione finiture metalliche.

Back frame in shaped plywood joined to the seat frame, legs in beech solid wood. Seat sprung system with twisted elastic belts. Upholstery in leather or fabric. Seat padding in polyurethane foam. Internal part of the back in polyurethane foam and acrylic fibres, parts padded individually. External part equipped with a 10 mm layer of polyurethane. Legs in polished lacquered beech wood with a vertical insert in 5 mm polished metal, available with chrome or gold finishing. Available also in high version with armrests. Available also with base in polished stainless steel with 5 laser-finished spokes, 8 mm in width, with aluminium turnings and chrome wheels, available in the metal finishing selection.

● [click here](#)

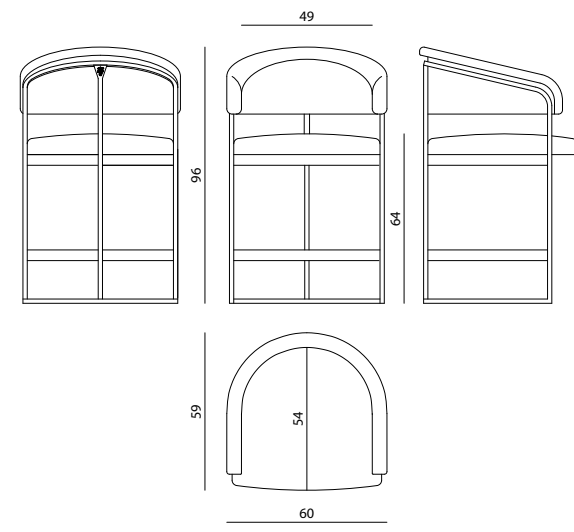
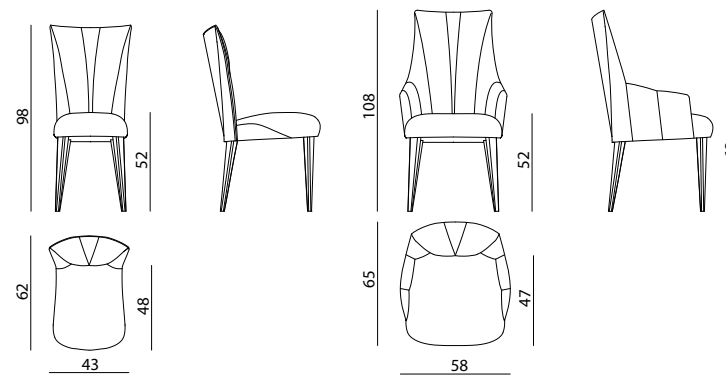



GINSBERG

POLTRONA DA UFFICIO - OFFICE ARMCHAIR
Samuele Mazza

Telaio schienale in multistrati sagomato, accorpato al telaio di seduta. Molleggio seduta con nastri elastici intrecciati. Rivestimento in pelle o tessuto. Imbottitura piano seduta in poliuretano. Parte interna schienale in poliuretano e falda acrilica con porzioni singolarmente imbottite. Parte esterna in lastra da 10 mm in poliuretano. Base in acciaio inox a 5 razze lavorato al laser da sp. 8 mm lucidato, con rotelle e torneria in alluminio regolabile in altezza disponibile nella selezione finiture metalliche.

Back frame in shaped plywood joined to the seat frame. Seat sprung system with twisted elastic belts. Upholstery in leather or fabric. Seat padding in polyurethane foam. Internal part of the back in polyurethane foam and acrylic fibres, parts padded individually. External part equipped with a 10 mm layer of polyurethane. Base in polished stainless steel with 5 laser-finished spokes, 8 mm in width, with aluminium turnings and chrome wheels, available in the metal finishing selection.

● click here

JERA

SEDIA IMBOTTITA - PADDED CHAIR
Steve Leung

Struttura in legno massello laccato lucido (colori RAL/NCS). Torneria retro-schienale e puntali in alluminio cromato, scocca in multistrati curvato rivestita all'esterno in pelle o tessuto, imbottita all'interno in poliuretano e tappezzata in pelle o tessuto, con lavorazione trapuntata. Le parti metalliche sono disponibili nella selezione finiture metalliche.

Disponibile nella versione JERA RADICA con scocca retro-schienale in radica con finitura lucida 100 gloss.

Structure in solid natural wood with shiny lacquered finishing (RAL/NCS colours). Turning on rear backrest and tips in chromed aluminium, curved plywood frame covered in fabric or leather on the outside; inside in polyurethane padding, upholstered in fabric or leather with quilted finishing. Metal parts available in the metal finishing selection.

Available in the JERA RADICA version with a briarwood backrest shell with a 100 gloss finish.



VERSIONE RADICA / RADICA VERSION

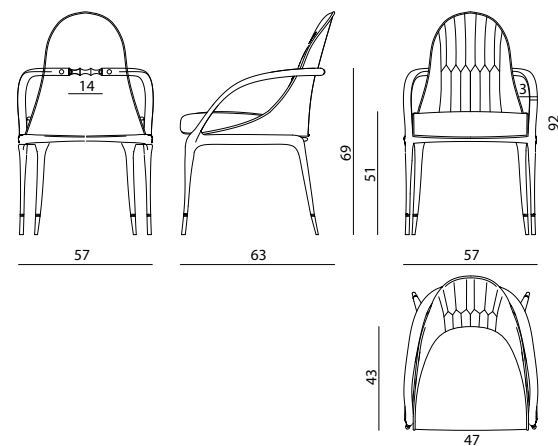

KYLO FRAMED

SEDIA - CHAIR
Alessandro La Spada

Sedia in legno curvato, con gambe in tubo metallico conifcato e piedi torniti. Tappezzeria trapuntata con rivestimento in pelle o tessuto e profili decorativi in alluminio satinato sullo schienale. Le parti in metallo sono disponibili nella selezione finiture metalliche.

Chair in curved wood, legs in conic-shaped metal tube and turned feet. Quilted upholstery in leather or fabric and backrest piping made in satin aluminium. Metal parts can be finished with any lacquer of the metal finish collection.

vedi anche/see also KYLO tavolo da pranzo-dining table

● click here

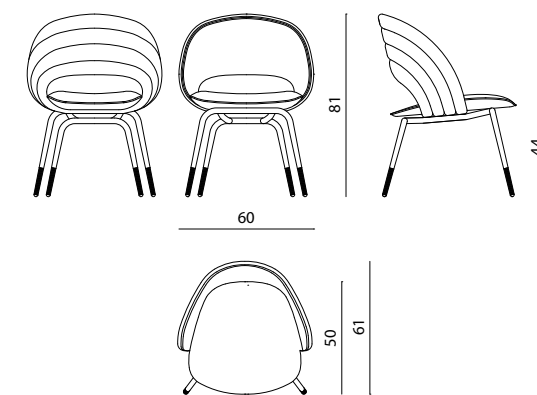

KYLO PADDED

SEDIA - CHAIR
Alessandro La Spada

Sedia in legno curvato, con gambe in tubo metallico conifcato e piedi torniti. Tappezzeria trapuntata con rivestimento in pelle o tessuto e filetti sul bordo schienale nello stesso materiale. Le parti in metallo sono disponibili nella selezione finiture metalliche.

Chair in curved wood, legs in conic-shaped metal tube and turned feet. Quilted upholstery in leather or fabric and backrest piping in leather or fabric. Metal parts can be finished with any lacquer of the metal finish collection.

vedi anche/see also KYLO tavolo da pranzo-dining table, KYLO PADDED dehors

● click here

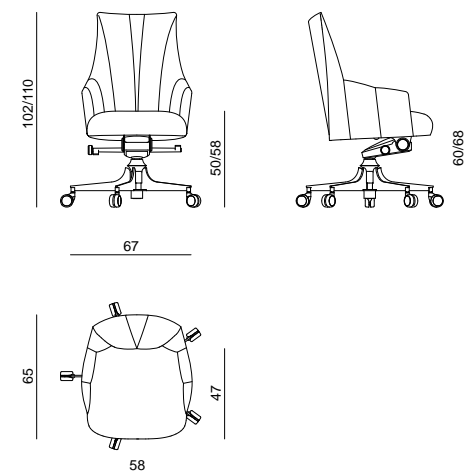
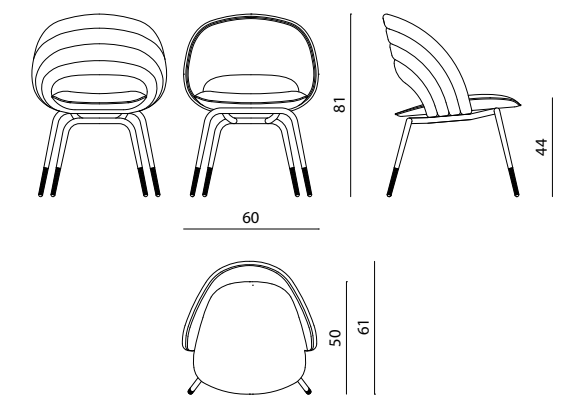



KYLO

SGABELLO - STOOL
Alessandro La Spada

Scocca in legno curvato, con gambe in tubo metallico conificato e piedi torniti. Tapppezzeria trapuntata con rivestimento in pelle o tessuto con fi-letti sui bordi. Le parti in metallo sono disponibili nella selezione finiture metalliche.

External structure in curved wood, with legs in conic metal tube and turned feet. Quilted upholstery in leather or fabric and matching pipings on the edges. Metal parts can be lacquered in any colour included in the metal finish selection.

vedi anche/see also KYLO tavolo da pranzo-dining table, KYLO PADDED dehors

● click here

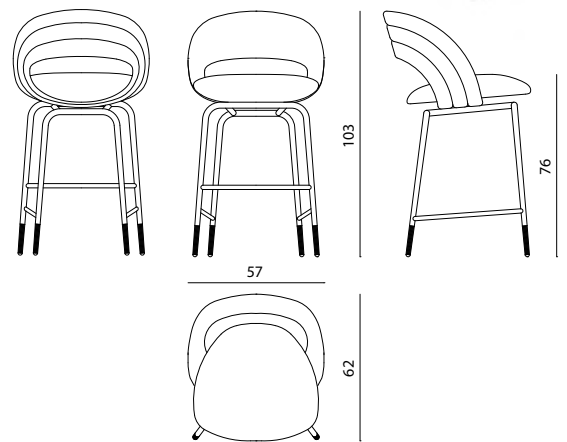

NANOOK

POLTRONA GIREVOLE - SWIVEL ARMCHAIR
Steve Leung

Struttura in legno massello multistrati sagomato, imbottitura in poliuretano espanso e molleggio seduta a cinghie elastiche, rivestimento in pelle o tessuto. Schienale alto con parte interna in poliuretano e falda acrilica con porzioni singolarmente imbottite, e parte esterna decorata con un ricamo in rilievo con motivo geometrico. Base in acciaio inox lucidato a cinque razze lavorate al laser, con rotelle e tornerie in alluminio, disponibile nella selezione finiture metalliche. Pistone ammortizzato girevole regolabile in altezza con sistema basculante bloccabile.

Structure in shaped plywood and solid wood, padding in polyurethane foam and spring system with straps, upholstery in leather or fabric. High back padded in polyurethane foam and acrylic fibres, portions padded individually; external part decorated with embroidery in relief, creating a geometrical pattern. Base in stainless steel with 5 laser-cut spokes, with wheels and turnings in aluminium, available in the metal finishing selection. Swivel shock absorber piston, adjustable in height, with lockable reclining system.

● click here

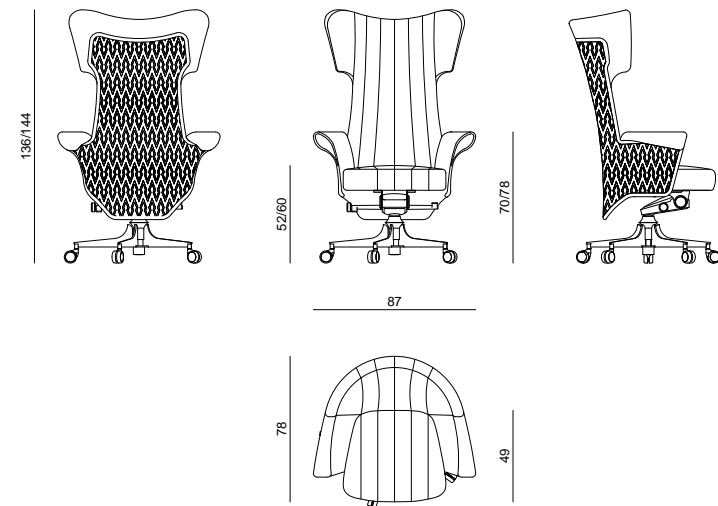

PALMYRA

SEDIA - CHAIR
Steve Leung

Scocca in multistrati curvato rivestita all'esterno in pelle o tessuto, imbottita all'interno in poliuretano e tappezzata in pelle o tessuto, con lavorazione trapuntata. Sedile con molleggio a cinghie elastiche imbottito in poliuretano e Memory Foam®. Gambe anteriori in legno massello sagomato e laccato lucido (colori RAL/NCS). Puntali in metallo disponibili nella selezione finiture metalliche.

Plywood curved structure covered externally in leather or fabric, padded on the inside part in polyurethane, and upholstered in leather or fabric with quilted finishing. Seat with sprung system with elastic bands, padded in polyurethane and Memory Foam®. Front legs in solid shaped and glossy lacquered wood (RAL/NCS colours). Metal tips available in the metal finishing selection.

● click here



VERSIONE RADICA/
RADICA VERSION

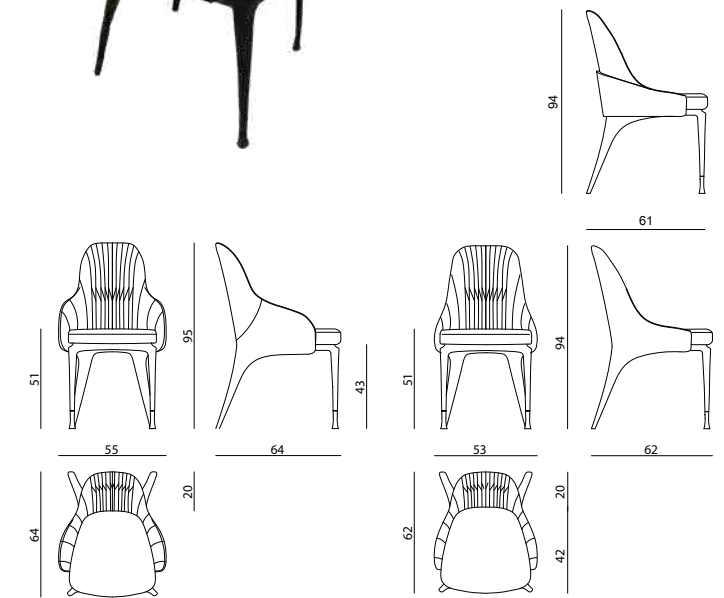

PLANET

POLTRONCINA DA UFFICIO - OFFICE ARMCHAIR
Steve Leung

Struttura portante in legno multistrati curvato e massello con molleggio di seduta a cinghie elastiche. Imbottitura di seduta e braccioli a densità differenziate. Rivestimento in pelle, con braccioli e schienale trapuntati con lavorazione a ricamo e traforatura. Scocca esterna curvata rivestita in pelle. Base in acciaio inox a cinque razze con rotelle, tornerie in alluminio. Pistone ammortizzato girevole regolabile in altezza con sistema basculante bloccabile. La base è disponibile nella selezione finiture metalliche.

Supporting frame in shaped plywood and solid wood; seat with elastic belt spring system. Seat and armrest padding with different densities. Upholstery in leather, armrests and backrest cover decorated with quilted embroidery and perforation pattern. Curved external structure upholstered in leather. Base in stainless steel with 5 wheels, turnings in aluminium. Rotary piston damper with self-locking drive system and adjustable height. Base can be finished with any lacquer of the metal lacquer finish selection.

● click here

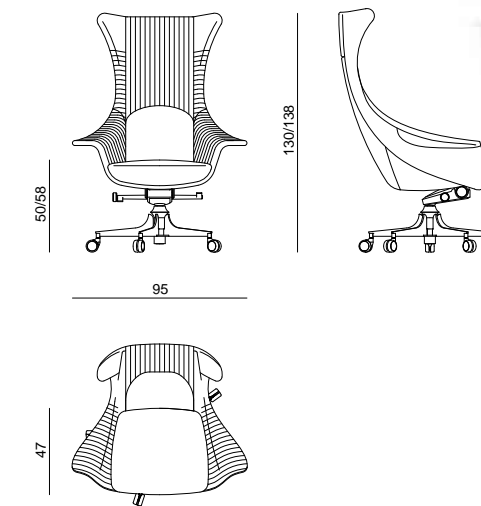



RHEA

SEDIA - CHAIR
Giuseppe Viganò

Struttura in legno massello interamente rivestita in pelle. Seduta con imbottitura in poliuretano a densità differenziata.

Structure in solid wood fully upholstered in leather. Seat padded in polyurethane with different densities.

● click here

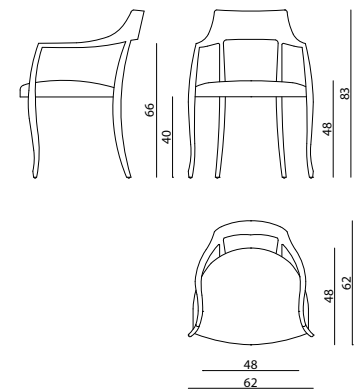

SADKO

POLTRONA DA UFFICIO - OFFICE ARMCHAIR
Alessandro La Spada

Struttura portante in legno multistrati curvato e massello. Imbottitura di seduta e braccioli a densità differenziate. Rivestimento in pelle o tessuto, con porzioni interne a imbottiture separate a tre zone per braccioli e schienale. Scocca esterna curvata rivestita in pelle o tessuto con cuciture decorative. Base in acciaio inox a cinque razze con rotelle, tornerie in alluminio. Pistone ammortizzato girevole regolabile in altezza. La base è disponibile nella selezione finiture metalliche.

Main structure in curved and solid multilayer wood. Seat and armrest padding in differentiated densities. Upholstery in leather or fabric, with separate three-zone upholstery for armrests and backrest. Curved outer shell covered in leather or fabric with decorative stitching. Five-spoke stainless steel base with castors, aluminium turnings. Cushioned swivel piston adjustable in height. The base is available in a selection of metal finishes.

● click here



SEKTOR

POLTRONA GIREVOLE - SWIVEL ARMCHAIR
La Conca

Poltrona da ufficio in pelle o tessuto. Scocca in multistrati di legno curvato e sagomato a spessore sottile, con rivestimento duotone con possibilità di abbinare pelle e/o tessuto. Nella versione in pelle, la parte interna dello schienale ha una lavorazione trapuntata e traforata a fasce verticali imbottite. Poggiatesta con logo ricamato. Base in acciaio inox girevole a 5 razze con ruote, regolazione in altezza con pistone a gas. Ruote ad alta scorrevolezza con battistrada antigraffio. Le parti metalliche sono disponibili nella selezione finiture metalliche.

Office armchair in leather or fabric. External structure in curved plywood with thin thickness, duotone upholstery available also in matching leather and/or fabric. If upholstered in leather, the internal part of the backrest is quilted in vertical padded strips decorated with a perforated pattern. Headrest with embroidered logo. Rotating base in stainless steel with 5-spokes wheels, adjustable in height. Ergo-glide wheels with antiscratch tread. Metal parts available with polished and satin lacquered finish.

● click here



STONE

SEDIA - CHAIR
Fabio Bonfà

Sedia in pelle o tessuto. Struttura in legno massello e multistrati. Gambe in faggio massello rivestite in pelle con puntali e tappi superiori in alluminio lucidato o satinato. Struttura portante del basamento in multistrati laccato nero lucido. Sedile e schienale in multistrati curvato e imbottito in poliuretano, con doppio rivestimento del sedile interno/esterno in pelle o tessuto. Filetti decorativi sui bordi dei pannelli. Le parti metalliche sono disponibili nelle finiture metalliche satinato.

Chair in leather or fabric. Frame in solid wood and plywood. Legs in beech solid wood covered in leather with polished or satin aluminium tips and top caps. Base supporting structure in glossy black lacquered plywood. Seat and backrest in curved plywood padded with polyurethane, with double upholstery on the inside/outside of the seat in leather or fabric. Decorative threads on the edges of the panels. Metal parts are available in satin-finish metal finishes.

● click here





SUNNY
POLTRONCINA - ARMCHAIR
Alessandro La Spada

Sedia imbottito con telaio in acciaio inox lucidato, struttura dello schienale curvato e del sedile in multistrati. Imbottitura in poliuretano a densità differenziate. Rivestimento in pelle o tessuto. Le parti in metallo sono disponibili nella selezione finiture metalliche.

Upholstered chair with frame in polished stainless steel, structure of the curved backrest and seat in plywood. Padding in polyurethane in different densities. Main upholstery in leather or fabric. Metal parts available in the metal finishing selection.

vedi anche/see also SUNNY dehors

● [click here](#)



SUNNY
SGABELLO - STOOL
Alessandro La Spada

Sgabello imbottito con telaio in acciaio inox lucidato, struttura dello schienale curvato e del sedile in multistrati. Imbottitura in poliuretano a densità differenziate. Rivestimento in pelle o tessuto. Le parti in metallo sono disponibili nella selezione finiture metalliche.

Upholstered stool with frame in polished stainless steel, structure of the curved backrest and seat in plywood. Padding in polyurethane in different densities. Main upholstery in leather or fabric. Metal parts available in the metal finishing selection.

vedi anche/see also SUNNY dehors

● [click here](#)



SYBILLA
SEDIA - CHAIR
Mauro Lipparini

Sedia tappezzata in pelle o tessuto con fusto in legno cinghiato e imbottitura in poliuretano a diverse densità. Schienale in legno curvo imbottito all'interno disponibile con superficie esterna scanalata con "effetto wave" rivestito in pelle. Gambe anteriori in metallo tubolare e gamba posteriore in piastra curva. Le parti metalliche sono disponibili nella selezione finiture metalliche.

Chair upholstered in leather or fabric with crawled wooden frame and polyurethane padding in different densities. Backrest in curved wood padded on the inside and available with grooved outer surface with "wave effect" covered in leather. Front legs in tubular metal and back leg in curved plate. Metal parts are available in the metal finish selection.

● [click here](#)



TANYA
POLTRONCINA, SEDIA - ARMCHAIR, CHAIR
Roberto Lazzeroni

Poltroncina monoscocca in poliuretano stampato a freddo con scocca interna in metallo. Rivestimento in pelle o tessuto; la parte esterna può essere rivestita in contrasto con la parte interna, divisa da un filetto in pelle, tappezzeria rifinita sul retro con cucitura manuale. Gambe costituite da una singola struttura in fusione di alluminio, con finitura antracite perlato e piedini in acciaio inox, disponibili nella selezione finiture metalliche.

Armchair in cold-cured PU Foam molding with internal metal shell. Upholstery in leather or fabric; the external part can be covered in contrast with the internal part, divided by a leather thread, upholstery finished on the back with manual stitching. Legs in aluminium cast, with pearl anthracite mattfinish and stainless steel feet, available in the metal finishing selection.

Winner of the 2018 Architizer A+Awards, "Commercial furniture" category

vedi anche/see also TANYA dehors

● [click here](#)

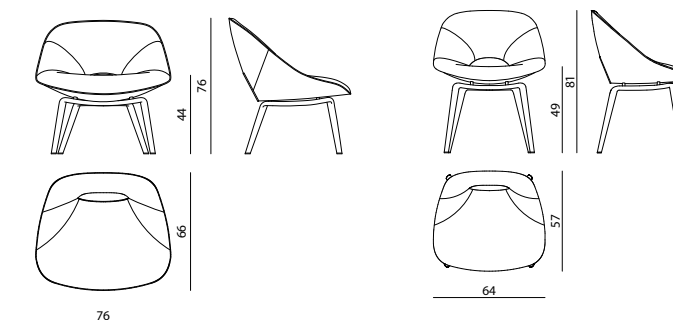
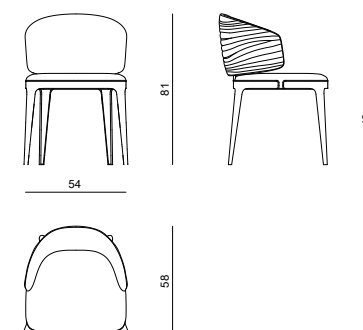
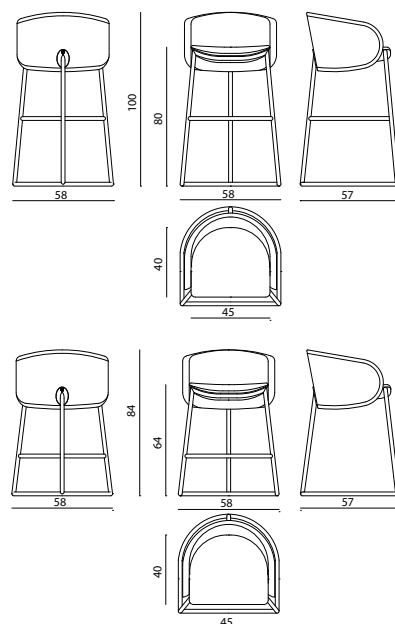
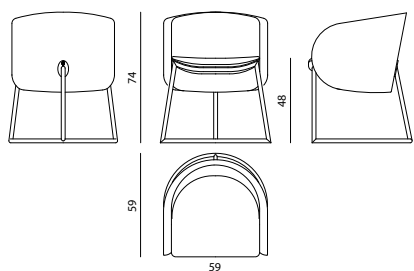



VOLVER

POLTRONCINA DA UFFICIO - OFFICE CHAIR

Roberto Lazzeroni

Poltroncina da ufficio in legno curvato e tappezzeria fissa in pelle o tessuto, con scocca esterna rivestita e sedile interno tappezzato con trapuntatura "canneté". Braccioli in alluminio satinato a sottile sezione ovale e forma "a torchon". Base in acciaio a 5 razze con ruote anti graffio. Le parti in metallo sono disponibili nella selezione finiture metalliche.

Office armchair in shaped wood with non-removable upholster in fabric or leather; external structure upholstered and internally decorated with quilted 'canneté' motif. Torchon-shaped armrests in satin aluminium with oval section. Base in steel with 5 anti-scratch wheels. Metal details can be finished with any lacquer of the metal lacquer finish selection.

● [click here](#)

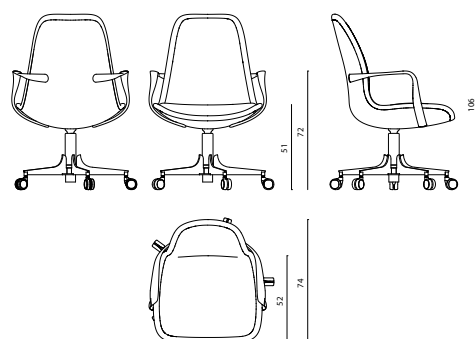

ZOE DECO

SEDIA - CHAIR

Draga & Aurel

Sedia tappezzata in pelle o tessuto con fusto in legno cinghiato e imbottitura in poliuretano a diverse densità. Gambe anteriori in metallo tubolare e gamba posteriore in piastra curva. Le parti metalliche sono disponibili nella selezione finiture metalliche con doppia finitura lucido/satinato sulla gamba posteriore mediante inserti in acciaio inox lucido.

Chair upholstered in leather or fabric with wooden frame and polyurethane padding in different densities. Front legs in tubular metal and back leg in curved plate. The metal parts are available in the metal finish selection with a double polished/satin finish on the rear leg by means of polished stainless steel inserts.

● [click here](#)

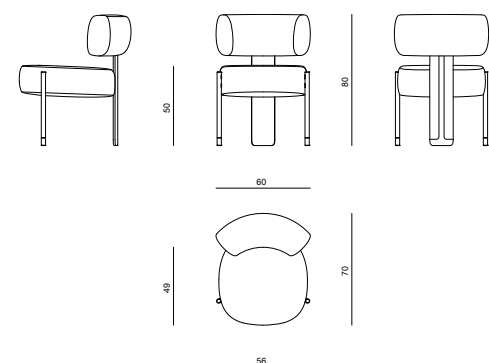



BOVERY

SEDIA - CHAIR
La Conca

Sedia rivestita in pelle o tessuto, con possibilità di bicolore e lavorazione interna capitonné. Scocca in multistrati di pioppo curvato. Imbottitura in poliuretano espanso. Gambe in acciaio cromato. Elemento decorativo in ottone e nappa in pelle sullo schienale. Le parti metalliche sono disponibili nella selezione finiture metalliche lucide.

Chair upholstered in leather or fabric, with possibility to choose two different colours and internal capitonné patterns. Structure in curved poplar plywood padded in polyurethane. Legs in chromed steel. To the rear backrest a decorative tassel composed of leather and brass is applied. Metal parts available in the polished metal finishing selection.

● click here

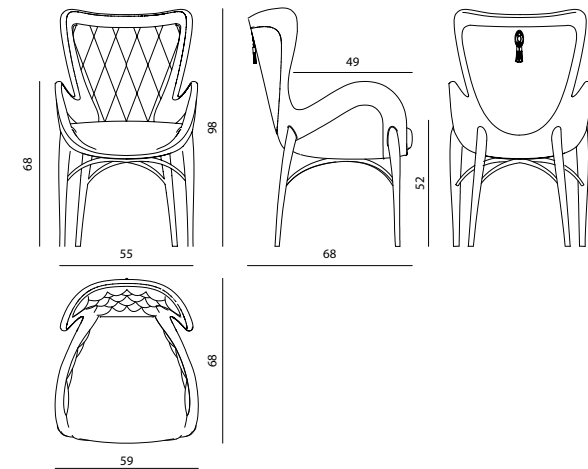

GRIMILDE

POLTRONCINA - ARMCHAIR
Alessandro La Spada

Struttura schienale in multistrato curvo di pioppo di 18 mm. Telaio sedile cinghiato con nastri elastici 60 mm incrociati. Imbottitura sedile in densità 45 kg/m³ portante il tutto ricoperto con lastra di Memory Foam® di 2 cm. Imbottitura spalliera in densità 40 kg/m³ portante. Il rivestimento interno viene trapuntato con lastra di gomma densità 30 kg/m³ portante per marcare le dime. Imbottitura esterna spalliera in densità 30 kg/m³ di 1 cm. Il basamento in acciaio viene bloccato al meccanismo girevole, e decorato con ovali in acciaio inox finitura lucida o disponibili nella selezione finiture metalliche.

Back structure in curved poplar plywood 18 mm. Seat frame made of twisted elastic belts 60 mm. Seat padding D. 45 kg/m³, all covered with a layer of Memory Foam® by 2 cm. Back padding D. 40 kg/m³. The internal cover is quilted to a layer D. 30 kg/m³ to mark the shape. External padding D. 30 kg/m³ th. 1 cm. The base in steel is fixed to the swivel mechanism and decorated with ovals in shiny stainless steel available in the metal finishing selection.

vedi anche/see also GRIMILDE mobile trucco-vanity unit, GRIMILDE SINGOLA wellness room

● click here

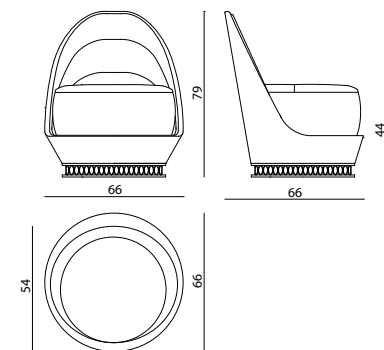

MAC KENZIE

POLTRONA GIREVOLE - SWIVEL ARMCHAIR
Alessandro la Spada

Struttura in multistrato di pioppo curvato ricoperta da imbottitura in poliuretano espanso, uno strato di Memory Foam® e falda acrilica. Rivestimento in pelle o tessuto. Su richiesta possibilità di ricamo "Lindoro" sui fianchi e/o logo "Visionnaire" sul retro. Base a 5 gambe in acciaio inox da 8 mm, lavorate al laser, con tornerie di alluminio e con ruote cromate.

Structure in curved poplar plywood, covered with a padding in polyurethane foam, a layer of Memory Foam® and acrylic fibre. Armchair upholstered in leather or fabric. "Lindoro" and/or "Visionnaire" logo embroidery on the back available upon request. Base with 5 laser-finished spokes in 8 mm stainless steel, with aluminium turnings and chromed wheels.

● click here

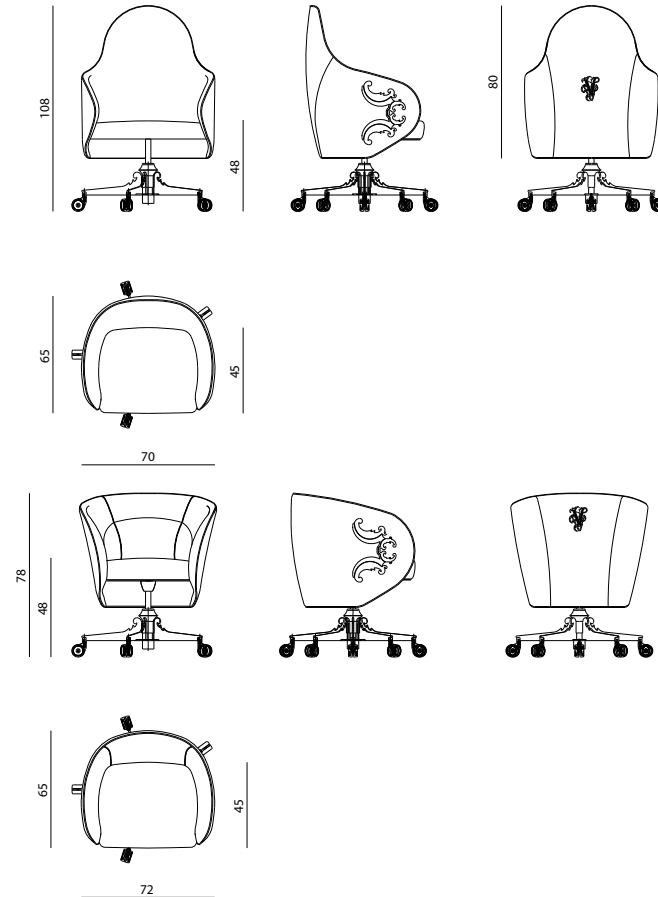

PRISCILLA

SEDIA ALTA, SEDIA - HIGH CHAIR, CHAIR
Alessandro La Spada

Sedia rivestita in pelle o tessuto, struttura portante in faggio massiccio laccato lucido. Elementi decorativi in alluminio e acciaio cromati sulle gambe. Sostegno schienale formato da due elementi cromati in alluminio e acciaio. Schienale in multistrati curvato con imbottitura in poliuretano; cuscino di seduta con molleggio a cinghie elastiche e imbottitura in poliuretano ad alta densità. Le parti metalliche sono disponibili nella selezione finiture metalliche.

Chair upholstered in leather or fabric. Supporting structure in solid beech wood glossy lacquered. Aluminium and chromed steel decorative elements applied on the legs. Two aluminium and chromed steel elements are fixed in backrest support which is made of curved multi plywood and padded with polyurethane. Seat cushion with elastic belts system and padded in high density polyurethane. Metal parts can be lacquered in any colour of the metal finish selection.

vedi anche/see also PRISCILLA divanetto-sofa

● click here

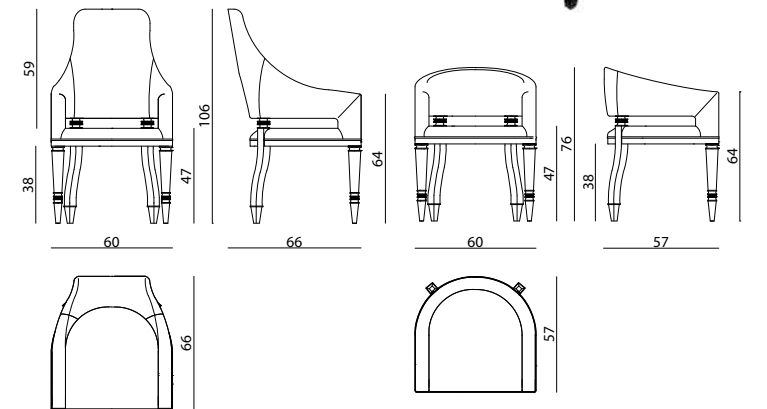



SÉVIGNÉ

SEDIA CAPOTAVOLA, SEDIA - HEAD OF TABLE CHAIR, CHAIR
Alessandro La Spada

Struttura portante in compensato multistrati di abete. Imbottitura in poliuretano espanso a densità differenziate con ricopertura a falde di Dacron®. Molleggio seduta a cinghie elastiche. Rivestimento non sfoderabile capitonné. Gambe frontali con elemento conico in ottone laccato ed inserto superiore in cristallo sfaccettato di forma cilindrica. Tornerie e puntale in metallo. Gambe posteriori in ottone a cono ricurvo laccato. Le parti metalliche sono disponibili nella selezione finiture metalliche.

Main structure in fir plywood. Padding in polyurthane in different densities with Dacron® layers. Seat sprung system made of elastic belts. Capitoné upholstery not removable. Front legs with cone element in lacquered brass and upper insert in multifaced cylindrical crystal. Turnings and tip in gold lacquered metal. Lacquered rear legs in brass with curved shape. Metal parts can be lacquered in any colour of the metal finish selection.

● click here

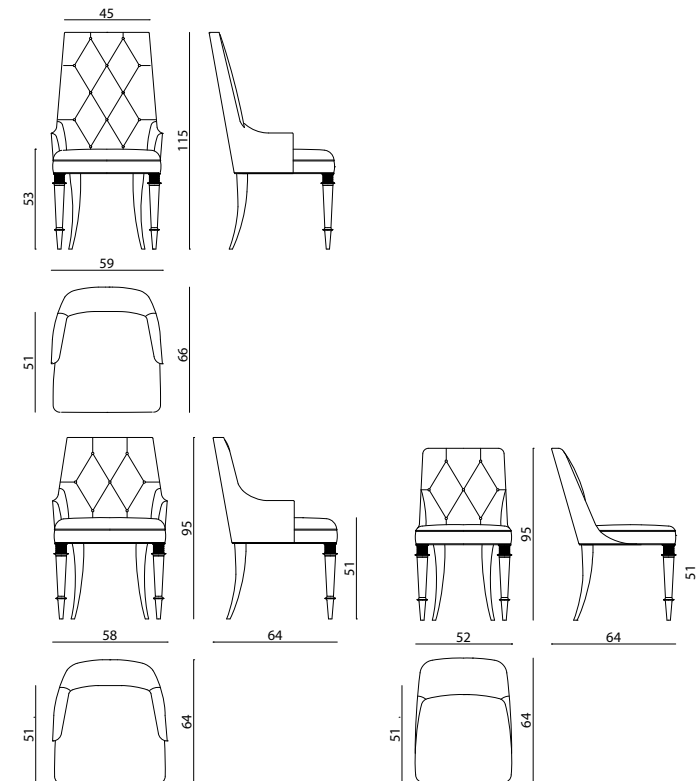

SÉVIGNÉ OFFICE

POLTRONA GIREVOLE - SWIVEL ARMCHAIR
Alessandro La Spada

Poltrona girevole imbottita in pelle o tessuto. Struttura in multistrato curvo, imbottitura in poliuretano espanso. Molleggio seduta a cinghie elastiche. Base in acciaio inox lucidato a 5 gambe lavorate al laser, con rotelle e tornerie in alluminio e pistone ammortizzato girevole con sistema basculante. Le parti in metallo sono disponibili nella selezione finiture metalliche.

Swivel padded armchair upholstered in leather or fabric. Structure in curved plywood, padding in polyurethane foam. Seat sprung system with elastic belts. Base in polished stainless steel with 5 spokes laser finishing, with wheels and aluminium turnings. Base structure is provided of swivel cushioned piston with reclining system. Metal parts available in the metal finishing selection.

● click here

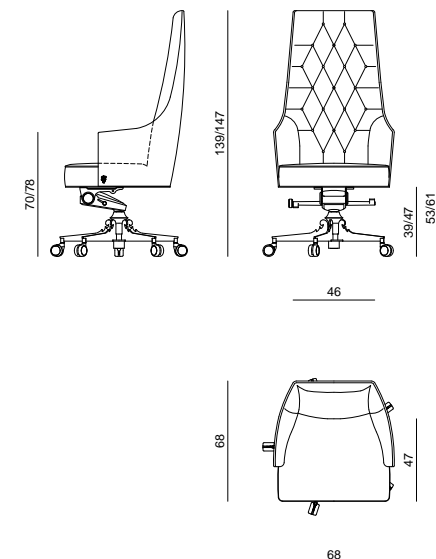

SIEGFRID

SEDIA CAPOTAVOLA - CHAIR AT THE HEAD OF THE TABLE
Alessandro La Spada - Samuele Mazza

Struttura portante in faggio massello e multistrato di pioppo e abete. Molleggio seduta a cinghie elastiche. Imbottitura schienale, bracciolo e seduta in poliuretano espanso a densità differenziata. Copertura in poliuretano con falda acrilica. Rivestimento non sfoderabile in pelle o tessuto con eventuale lavorazione capitonné sullo schienale. Filetti decorativi in pelle. Gambe anteriori in torneria di alluminio cromato, gambe posteriori rivestite della stessa pelle/tessuto della struttura.

Main structure in solid beech and poplar and fir plywood. Seating sprung system with elastic belts. Padding for backrest, armrest and seat cushion in polyurethane foam, different densities. The polyurethane is covered with an acrylic layer. Head of table chair upholstered in leather or fabric with possibility of capitonné finishing on the backrest. Decorative pipings in leather. Cover not removable. Front legs in turned chromed or golden/brass aluminium and back legs upholstered.

vedi anche/see also SIEGFRID panca-bench

● click here

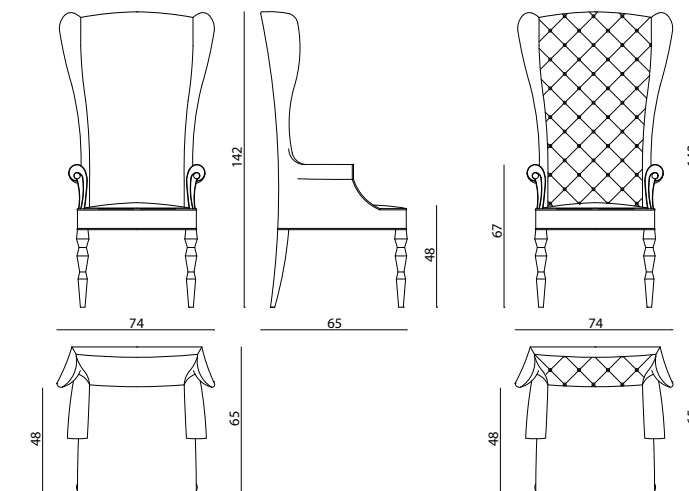

SIEGFRID

SEDIA - CHAIR
Alessandro La Spada

Struttura in abete e faggio massello e multistrato di pioppo. Imbottitura in poliuretano di varie densità. Sistema molleggio seduta a cinghiatura elastica ricoperto da uno strato di Memory Foam®. Rivestimento non sfoderabile in pelle o tessuto con filetti decorativi e lavorazione interno schienale capitonné. Le gambe anteriori sono in alluminio cromato o laccato oro/bronzo mentre quelle posteriori sono rivestite.

Structure in solid fir and beech wood and poplar plywood. Padding in polyurethane of different densities. Seat sprung system with elastic belts covered by a layer of Memory Foam®. Chair upholstered in leather or fabric with decorative pipings and front part of backrest in capitonné finishing. Front legs in chromed or golden/bronze lacquer aluminium and back legs upholstered.

● click here

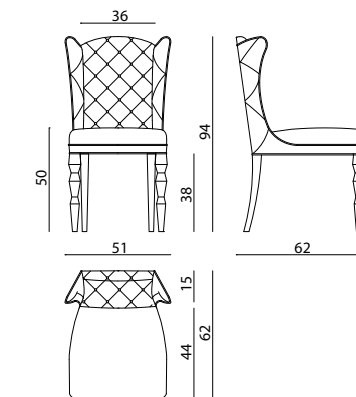



YORK

POLTRONCINA GIREVOLE - SWIVEL ARMCHAIR

Alessandro La Spada - Samuele Mazza

Struttura principale in legno multistrati di abete con tamponature in masonite. Molleggio con cinghie elastiche. Imbottitura seduta in poliuretano D. 30 kg/m³; imbottitura braccioli e schienale in poliuretano D. 40 kg/m³; imbottitura braccioli e schienale in poliuretano D. 40 kg/m³. Rivestimento in pelle, con porzione centrale dello schienale tappezzato a capitonné: non sfoderabile. Completa di cuscinetto appoggiatesta in pelle con imbottitura in piuma e contrappeso con elementi torniti in alluminio cromato. Base girevole con possibilità di regolazione dell'altezza e dell'inclinazione dello schienale. Incisione di logo e stemma araldico Visionnaire su piastra/zavorra.

Main structure in fir plywood with fillings in masonite. Seating system with elastic belts. Seat filling in polyurethane D. 30 kg/m³; filling of armrests and back in polyurethane D. 40 kg/m³. Cover in leather, with central portion of back upholstered capitonné: not removable. Complete with headrest cushion in leather with filling in feathers and counterweight with turned elements in chromed aluminium. Swivel base with possibility of height regulation and inclination. Incision of logo and Visionnaire coat of arms on base anchor/plate.

● [click here](#)

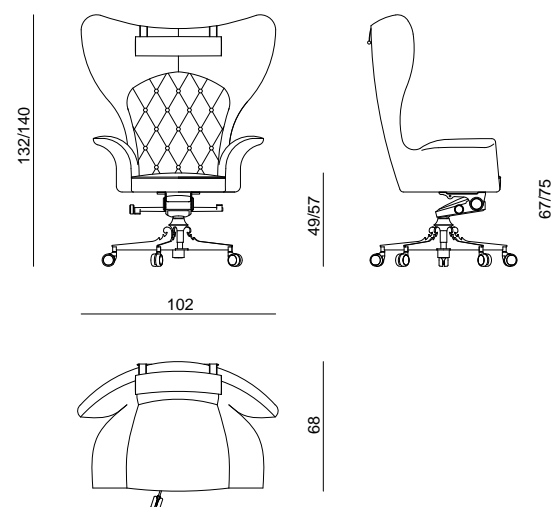

- click on the icons -



AUBADE LARGE p.152



AUBADE REGULAR p.153



BALANCE p.154



CA' FOSCARI p.155



BASTIAN LARGE p.156



BASTIAN REGULAR p.157



BELOVED p.158



BELOVED ART p.159



EMOTION p.160



HEMINGWAY p.161



LE COMTE p.162



LEONARDO p.163



PERKINS p.164



PALAU REGULAR p.165



PLAZA p.166

- click on the icons -



PORFIRIO p.167



PRINCESS p.168



RÊVERIE p.169



ULTRASOUND LARGE p.170



ULTRASOUND REGULAR p.171



RIPLEY p.172

ICONICI - *ICONIC*



BRADLEY p.174



WOTTON BELT p.175



WOTTON METAL p.176



AUBADE LARGE

LETTO - BED

Alessandro La Spada

Letto tappezzato in pelle o tessuto. Testata tappezzata con pannelli rettangolari in legno leggermente imbottiti rivestiti singolarmente, separati da inserti in acciaio inox. Cornice perimetrale con pannelli in marmo incassati con luce di cortesia a LED. Zoccolo e inserti in acciaio inox. Predisposizione per attacco a parete. Giroletto in multistrati imbottito in poliuretano a più elementi rivestiti. Base in acciaio inox. Rete a doghe in legno, supporto rete costituito da quattro angolari più traversa centrale, regolabili in altezza, in acciaio verniciato. Le parti metalliche sono disponibili nella selezione finiture metalliche.

Abbinabile a set lenzuola Sunrise.

Bed upholstered in leather or fabric. Headboard made of rectangular wooden panels slightly padded and upholstered individually, separated by inlays in stainless steel. Perimetral frame with built-in marble panels with LED courtesy light. Plinth and inserts in stainless steel. Predisposed for wall fixing. Bedframe in multiply wood padded in polyurethane and made of single upholstered elements. Stainless steel base. Wooden slats supported by four corner brackets and one central rod, with adjustable height. The metal parts are available in the metal finishes selection.

Shown with Sunrise sheets set.

vedi anche/see also AUBADE comodino-bedside table

● [click here](#)

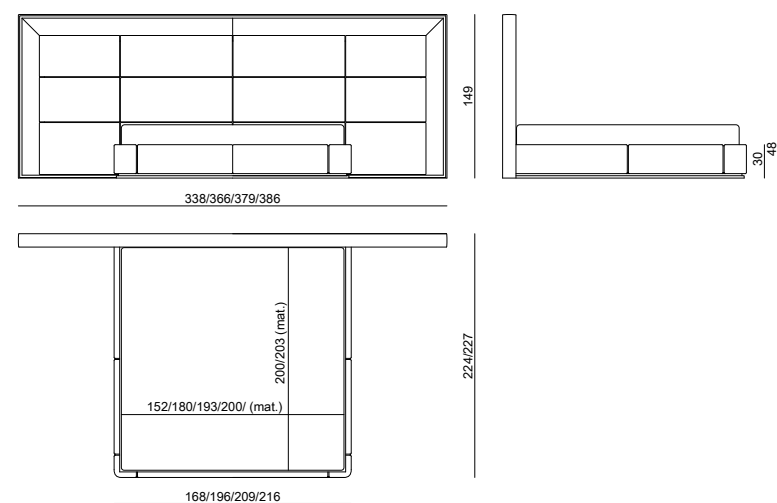

AUBADE REGULAR

LETTO - BED

Alessandro La Spada

Letto tappezzato in pelle o tessuto. Testata tappezzata con pannelli rettangolari in legno leggermente imbottiti rivestiti singolarmente, separati da inserti in acciaio inox. Cornice perimetrale con pannelli in marmo incassati con luce di cortesia a LED. Zoccolo e inserti in acciaio inox. Predisposizione per attacco a parete. Giroletto in multistrati imbottito in poliuretano a più elementi rivestiti. Base in acciaio inox. Rete a doghe in legno, supporto rete costituito da quattro angolari più traversa centrale, regolabili in altezza, in acciaio verniciato. Le parti metalliche sono disponibili nella selezione finiture metalliche.

Abbinabile a set lenzuola Sunrise.

Bed upholstered in leather or fabric. Headboard made of rectangular wooden panels slightly padded and upholstered individually, separated by inlays in stainless steel. Perimetral frame with built-in marble panels with LED courtesy light. Plinth and inserts in stainless steel. Predisposed for wall fixing. Bedframe in multiply wood padded in polyurethane and made of single upholstered elements. Stainless steel base. Wooden slats supported by four corner brackets and one central rod, with adjustable height. The metal parts are available in the metal finishes selection.

Shown with Sunrise sheets set.

vedi anche/see also AUBADE comodino-bedside table

● [click here](#)

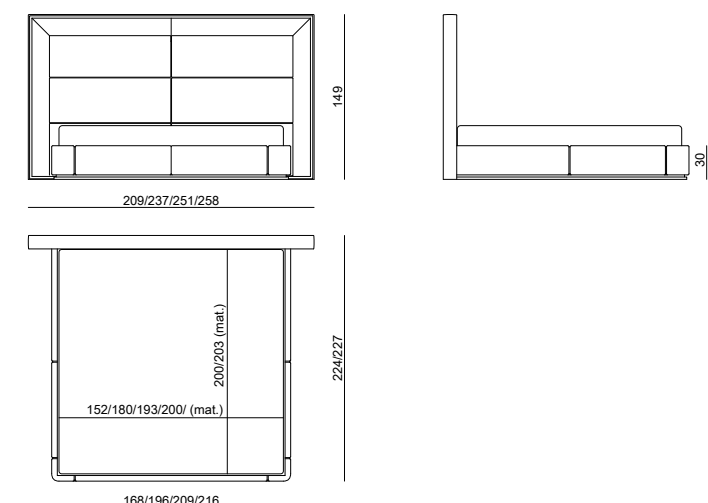



BALANCE

LETTO - BED

Alessandro La Spada

Letto tappezzato in pelle o tessuto. Struttura interna in legno massello e multistrati sagomati, imbottitura in poliuretano espanso a densità differenziate. Testata sagomata tappezzata internamente con porzione centrale trapuntata con memory foam. Sommier con spigoli sagomati. Rete a doghe in legno, supporto rete costituito da quattro angolari più traversa centrale, regolabili in altezza, in acciaio verniciato. Base in MDF laccato bordato in acciaio inox satinato disponibile nella selezione finiture metalliche. Disponibile in versione PLAIN con testata senza trapuntatura.

Bed upholstered in leather or fabric. Structure in solid wood and moulded plywood, padding in polyurethane foams in different densities. Shaped headboard with quilted central section padded with memory foam. Bed base with rounded corners. Wooden slats supported by four corner braces and one central rod in steel with lacquer finish, adjustable in height. Base in lacquered MDF with profile in satin steel, available in any finish of the metal lacquer finish selection.

Available in PLAIN version, with headboard without quilting.

LETTO CON PANCA - BED WITH BENCH

Letto tappezzato in pelle o tessuto. Struttura interna in legno massello e multistrati sagomati, imbottitura in poliuretano espanso a densità differenziate. Testata sagomata tappezzata internamente con porzione centrale trapuntata con memory foam. Sommier completo di una panca di servizio con cuscini di seduta in poliuretano e Memory Foam®. Rete a doghe in legno, supporto rete costituito da quattro angolari più traversa centrale, regolabili in altezza, in acciaio verniciato. Base in MDF laccato bordato in acciaio inox satinato disponibile nella selezione finiture metalliche.

Disponibile in versione PLAIN con testata senza trapuntatura.

Bed upholstered in leather or fabric. Structure in solid wood and moulded plywood, padding in polyurethane foams in different densities. Shaped headboard with quilted central section padded with memory foam. Bed base with rounded corners and footboard with seat cushions padded in polyurethane foam and Memory Foam®. Wooden slats supported by four corner braces and one central rod in steel with lacquer finish, adjustable in height. Base in lacquered MDF with profile in satin steel, available in any finish of the metal lacquer finish selection.

Available in PLAIN version, with headboard without quilting.

VERSIONE CON INTERNO TESTATA TRAPUNTATA - VERSION WITH QUILTED HEADBOARD

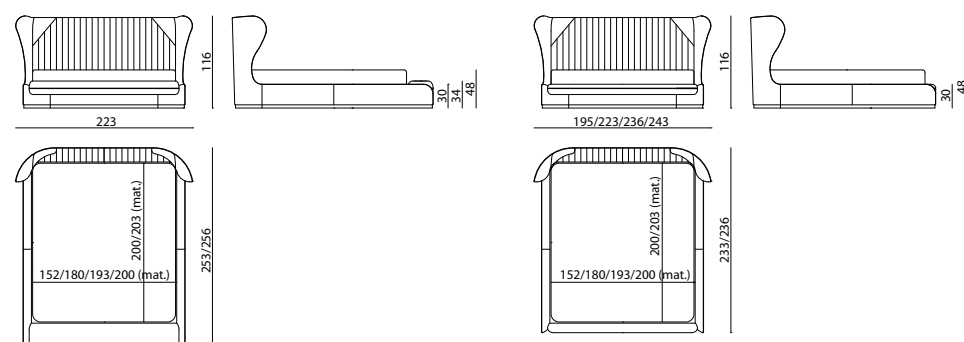

VERSIONE CON INTERNO TESTATA LISCIO - VERSION WITH PLAIN HEADBOARD

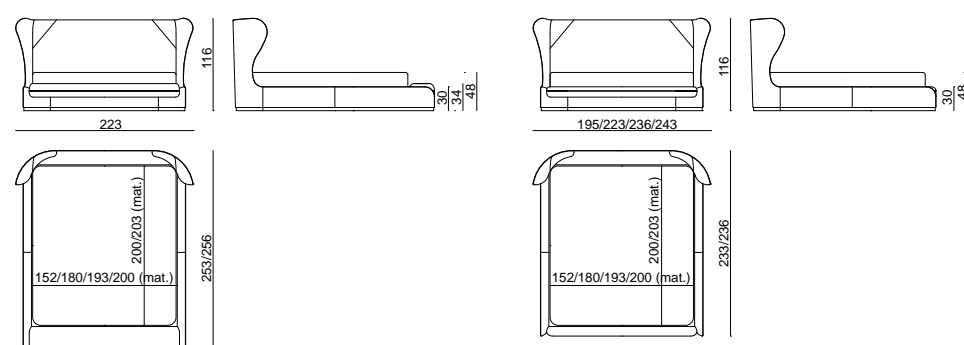

vedi anche/see also BALANCE divano, poltrona, chaise-longue, pouf-sofa, armchair, chaise-longue, pouffe

click here

CA' FOSCARI

LETTO - BED

Alessandro La Spada

Versione large e regular: Letto con tappezzeria fissa in pelle o tessuto con testata ricamata e trapuntata con grafica dedicata. Sommier sagomato a profilo bombato. Fusto in legno multistrati e massello con rete integrata in doghe di legno, imbottitura in poliuretano a diverse densità. Base sagomata in legno rivestita in acciaio inox curvato a profilo concavo, sia per testata che per sommier. Testata e sommier vengono forniti smontati. Le parti decorative in metallo sono disponibili nella selezione finiture metalliche.

Abbinabile al set lenzuola, cuscini e copriletto Cala Luna.

Large and Regular version: Bed with non-removable upholstery in leather or fabric; headboard with dedicated quilted embroidery. Shaped bed base with rounded profile. Structure in plywood and solid wood with integrated wooden slats, padding in differentiated-density polyurethane foam. Shaped base of headboard and bed base made in wood, covered in curved stainless steel with concave profile. Headboard and bed base are provided disassembled. Decorative metal elements can be finished with any lacquer of the metal lacquer finish selection.

Shown with bed linings, pillows and bedcover Cala Luna.

vedi anche/see also CA' FOSCARI divano, poltrona-sofa, armchair, CA' FOSCARI comodino-bedside table

click here

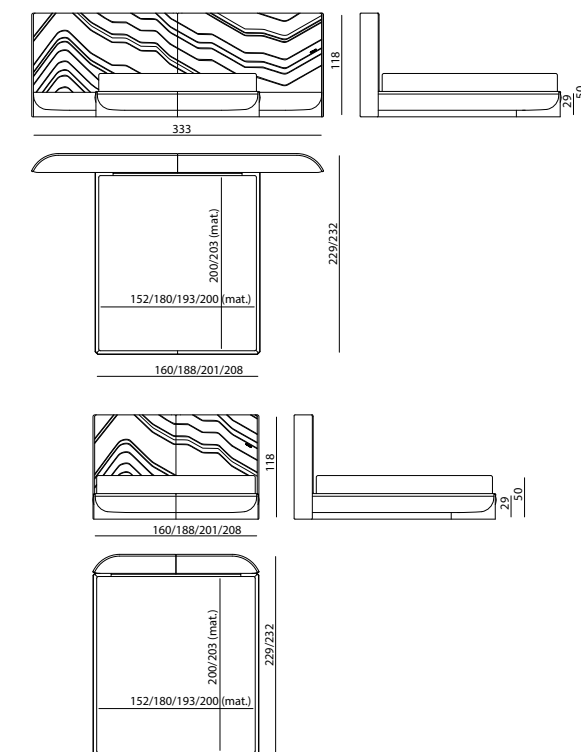



BASTIAN LARGE

LETTO - BED

Mauro Lipparini

Letto tappezzato in pelle o tessuto. Struttura interna in legno massello e multistrati sagomati, imbottitura in poliuretano espanso a densità differenziate. Testata sagomata tappezzata decorata con filetti e fettucce ribattute in pelle a contrasto, fornita di due guanciali decorativi in piuma nello stesso rivestimento. Sommier composto da tre elementi tappezzati decorati con filetti e fettucce in pelle a contrasto. Fregi nel sommier in alluminio e acciaio inox satinato a doppia finitura disponibili nella selezione finiture metalliche. Rete a doghe in legno, supporto rete costituito da quattro angolari più traversa centrale, regolabili in altezza, in acciaio verniciato. Disponibile con luce di cortesia a LED montata sotto il profilo della testata.

Abbinabile a set lenzuola, cuscini e copriletto Mirabell.

Bed upholstered in leather or fabric. Internal structure in solid wood and shaped plywood, padding in polyurethane foam with different densities. Shaped headboard padded and decorated with piping and edges with topstitching in leather with contrasting colour. Two decorative pillows in feather with the same upholstery are provided. Bed-frame composed by three elements padded and decorated with piping and edges in contrasting leather. Friezes on the bed frame are in aluminium and satin stainless steel, with double finish. They can be lacquered in any colour included in the metal finish selection. Slats in wood are supported by four corner brackets and one central rod, with adjustable height, in varnished steel. LED courtesy light can be mounted under the headboard profile upon request.

Shown with bed linings, pillows and bedcover Mirabell.

vedi anche/see also BASTIAN divano, poltrona, chaise-longue, pouf-sofa, armchair, chaise-longue, pouffe

[click here](#)

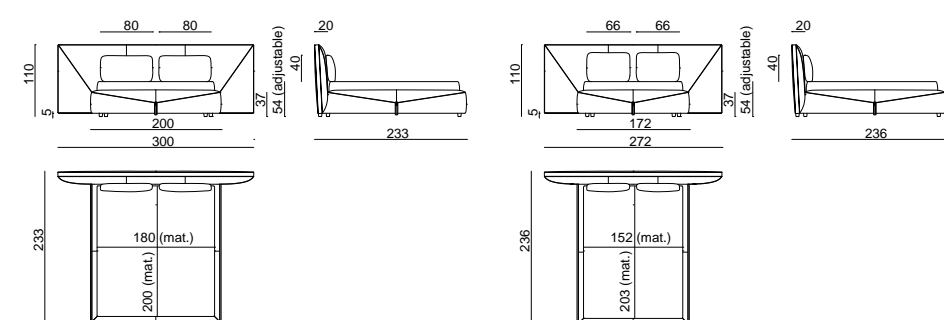
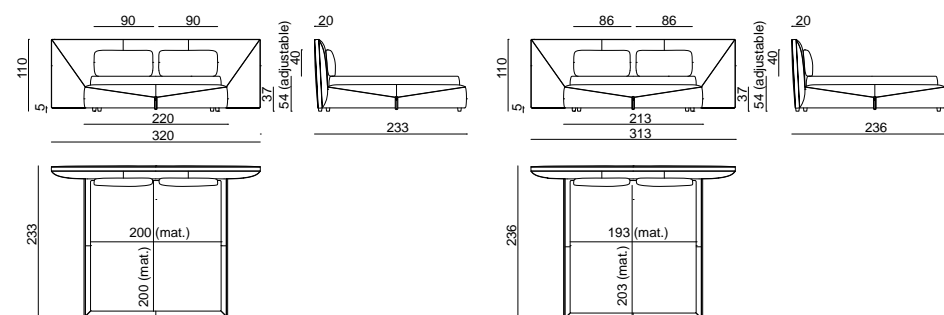

BASTIAN REGULAR

LETTO - BED

Mauro Lipparini

Letto tappezzato in pelle o tessuto. Struttura interna in legno massello e multistrati sagomati, imbottitura in poliuretano espanso a densità differenziate. Testata sagomata tappezzata decorata con filetti e fettucce ribattute in pelle a contrasto, fornita di due guanciali decorativi in piuma nello stesso rivestimento. Sommier composto da tre elementi tappezzati decorati con filetti e fettucce in pelle a contrasto. Fregi nel sommier in alluminio e acciaio inox satinato a doppia finitura disponibili nella selezione finiture metalliche. Rete a doghe in legno, supporto rete costituito da quattro angolari più traversa centrale, regolabili in altezza, in acciaio verniciato.

Abbinabile a set lenzuola, cuscini e copriletto Mirabell.

Bed upholstered in leather or fabric. Internal structure in solid wood and shaped plywood, padding in polyurethane foam with different densities. Shaped headboard padded and decorated with piping and edges with topstitching in leather with contrasting colour. Two decorative pillows in feather with the same upholstery are provided. Bed-frame composed by three elements padded and decorated with piping and edges in contrasting leather. Friezes on the bed frame are in aluminium and satin stainless steel, with double finish. They can be lacquered in any colour included in the metal finish selection. Slats in wood are supported by four corner brackets and one central rod, with adjustable height, in varnished steel.

Shown with bed linings, pillows and bedcover Mirabell.

[click here](#)

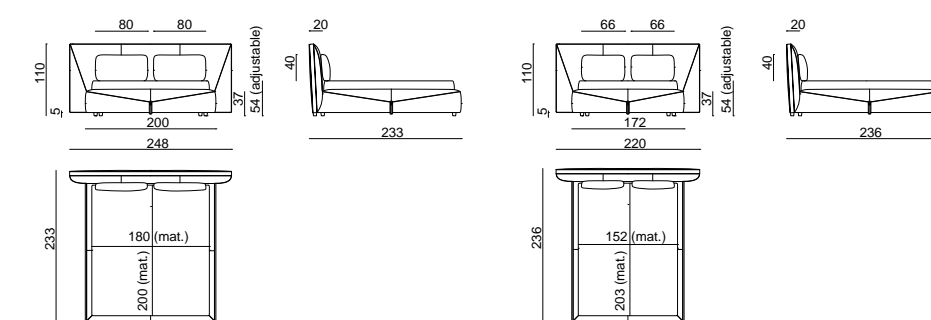
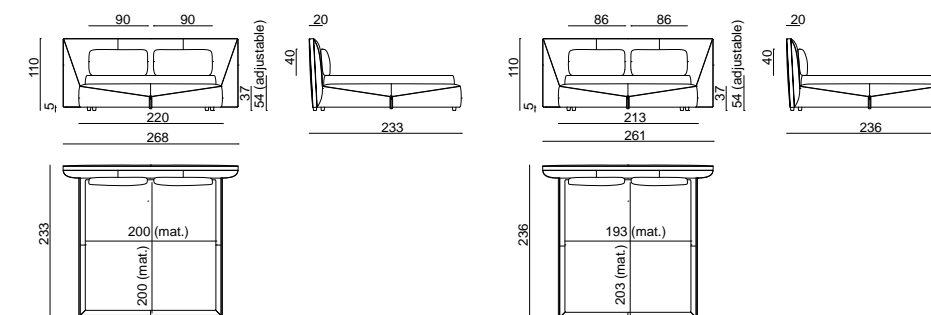



BELOVED

LETTO - BED

Alessandro La Spada

Letto tappezzato in pelle o tessuto. Testata tappezzata con trama geometrica, struttura in multistrati con pannelli leggermente imbottiti rivestiti singolarmente. Zoccolo e inserti in acciaio inox satinato con logo inciso, predisposizione per attacco a parete. Giroletto in multistrati imbottito in poliuretano a più elementi rivestiti singolarmente, decorati con quattro inserti in acciaio inox satinato. Base in acciaio inox satinato. Rete a doghe in legno, supporto rete costituito da quattro angolari più traversa centrale, regolabili in altezza, in acciaio verniciato. Opzione: parti metalliche disponibili nella selezione finiture metalliche.

Abbinabile a set lenzuola e copripetto Ernon.

Bed upholstered in leather or fabric. Upholstered headboard with geometrical pattern, structure in plywood with slightly padded panels upholstered individually. Plinth and inserts in satinized stainless steel with engraved logo, predisposed for wall fixing. Bed base in plywood padded in polyurethane, made of several elements individually upholstered, decorated with four inserts in satinized stainless steel. Base in satinized stainless steel. Wooden slats with 4 corner supports and central bar, adjustable in height, in varnished steel. Metal parts available in the metal finishing selection.

Shown with bed linings and bedcover Ernon.

vedi anche/see also BELOVED comodino-bedside table

click here

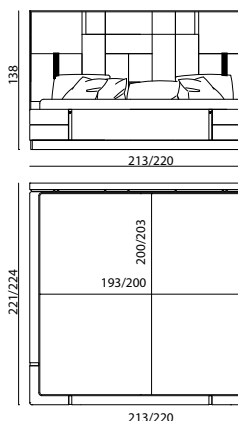
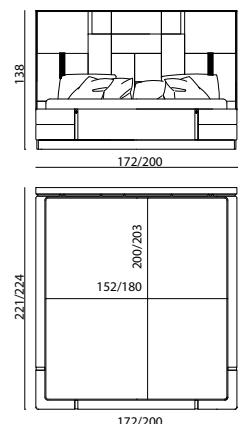
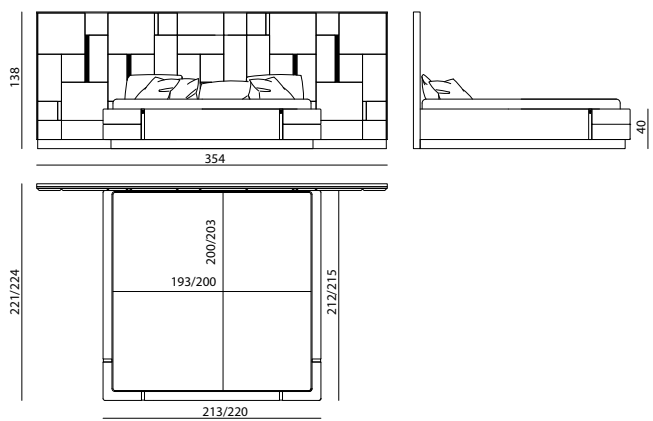
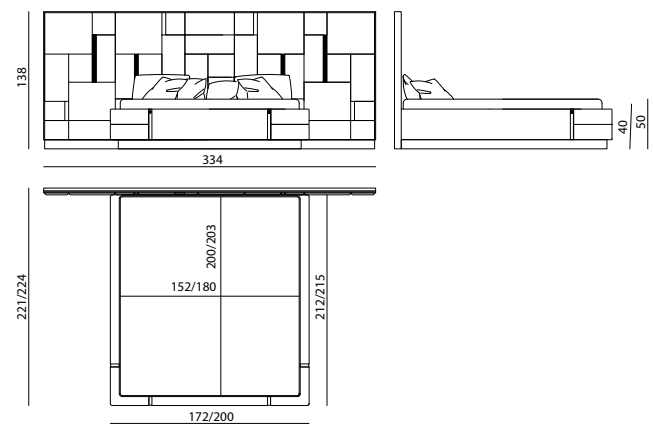

BELOVED ART

LETTO - BED

Alessandro La Spada - Michele Astolfi

Letto tappezzato in pelle o tessuto. Testata tappezzata con trama geometrica, struttura in pannelli di multistrati e legno massello con pannelli leggermente imbottiti rivestiti singolarmente. Lo zoccolo e gli inserti decorativi nel sommier e nella testata sono in acciaio inox satinato. Nicchia portaoggetti con fondo rivestito da pannello artistico by Michele Astolfi in policarbonato stampato e decorato con inserti in vetro artistico e cristalli Swarovski. Illuminazione di cortesia a LED. La testata viene fornita smontata e predisposta per attacco a parete. Giroletto in multistrati imbottito in poliuretano a più elementi rivestiti singolarmente, decorati con quattro inserti e base in acciaio inox satinato. Rete a doghe in legno, supporto rete costituito da quattro angolari più traversa centrale, regolabili in altezza, in acciaio verniciato. Le parti decorative in metallo sono disponibili nella selezione finiture metalliche.

Abbinabile a set lenzuola, cuscini e copripetto Ernon.

Bed upholstered in leather or fabric. Headboard padded as to design a geometric pattern; structure in plywood panels and solid wood with slightly padded tiles, upholstered one by one. Plinth and decorative elements inserted into bed base and headboard in stainless steel with satin finish. Storage compartment with back panel decorated with artistic artwork by Michele Astolfi made in printed polycarbonate and decorated with inserts in artistic glass and Swarovski crystals. LED courtesy lights. Headboard provided disassembled and designed to be installed on the wall. Bed base in plywood padded with polyurethane foam, consisting of several elements upholstered one by one and decorated with inserts and base in satin stainless steel. Wooden slats, slats supported by four corner braces and one central rod in lacquered steel, adjustable in height. Decorative metal elements can be finished with any lacquer of the metal lacquer finish selection.

Shown with bed linings, pillows and bedcover Ernon.

click here

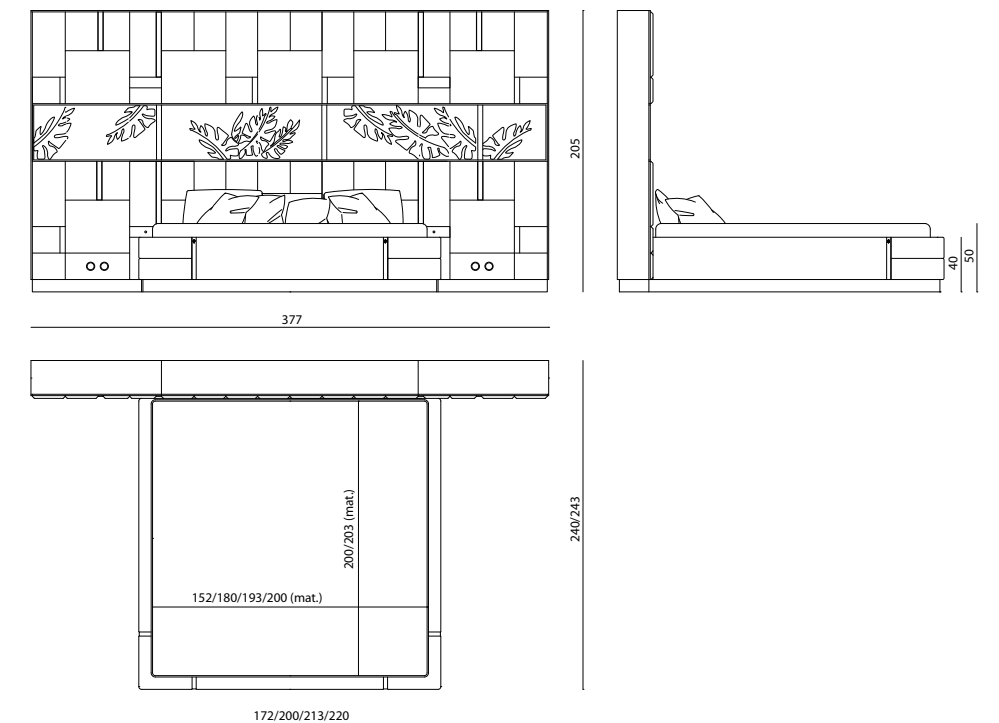



EMOTION

LETTO - BED

La Conca

Letto tappezzato in pelle o tessuto. Struttura della testata in legno impiallacciato in essenza laccata lucida in multistrati con pannelli imbottiti rivestiti singolarmente, con vani a giorno e due vani nascosti con apertura a ribalta a richiesta, rivestiti internamente in pelle o tessuto. Comodini con cassetto integrati. Zoccolo di testata e sommier in legno, inserti in acciaio inox satinato, predisposizione per attacco a parete. Giroletto in multistrati imbottito in poliuretano. Rete a doghe in legno, supporto rete costituito da quattro angolari più traversa centrale, regolabili in altezza, in acciaio verniciato. Fornito con illuminazione a LED in tutti i vani. Le parti metalliche sono disponibili nella selezione finiture metalliche.

Abbinabile a set lenzuola, cuscini e copriletto Isydor.

Bed upholstered in leather or fabric. Structure of the headboard in plywood covered in veneered wood with polish lacquering, padded panels upholstered one-by-one, two hidden storage compartments with flap-door opening system, internally upholstered in leather or fabric. Integrated bedside table. Headboard and bedframe plinth in wood, inserts in satinized stainless steel. Equipped for wall-mounting. Bedframe in plywood padded with polyurethane. Wooden slats supported by four corner elements and a central bar, adjustable in height, in lacquered steel. All the storage compartments are equipped with LED lights. Metal parts available in the metal finishing selection.

Shown with bed linings, pillows and bedcover: Isydor.

● click here

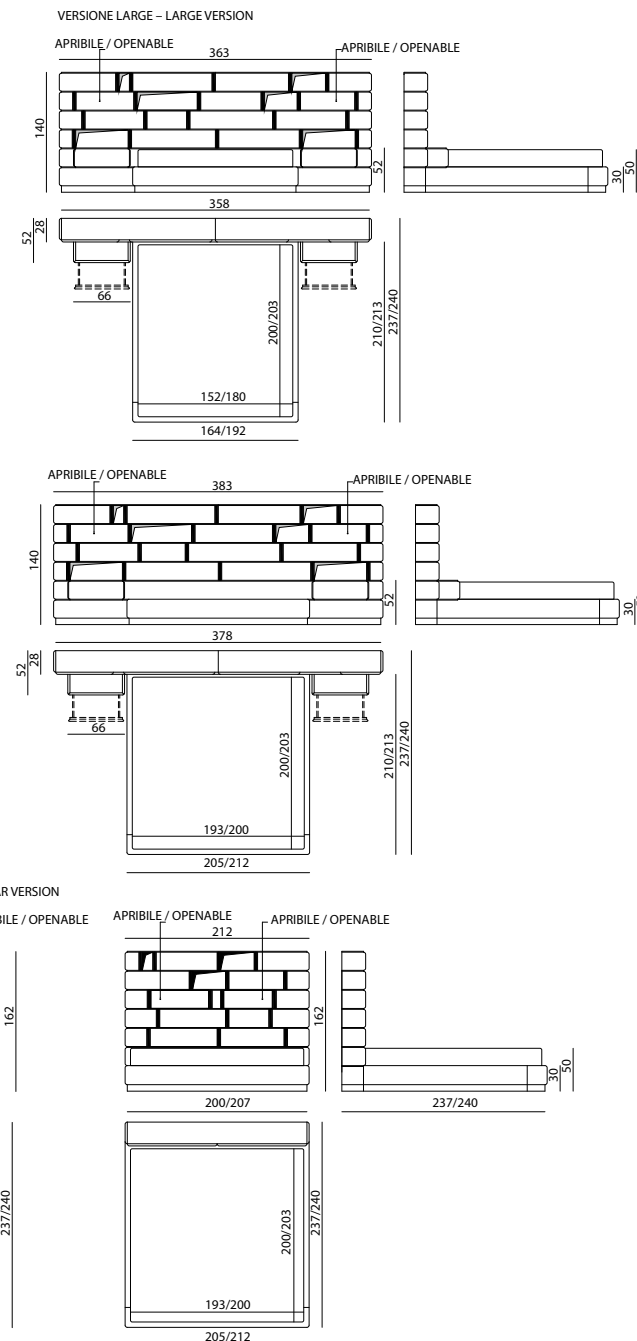

HEMINGWAY

LETTO, LETTO CON PANCA

BED, BED WITH BENCH

Samuele Mazza

Letto tappezzato in pelle o tessuto. Struttura interna in legno massello e multistrati sagomati, imbottitura in poliuretano espanso a densità differenziate. Testata sagomata tappezzata internamente con pannelli imbottiti singolarmente. Sommier con spigoli sfaccettati completato da una panca di servizio con cuscini di seduta in poliuretano e Memory Foam® e piume d'oca. Schienale imbottito con pannelli rivestiti singolarmente. Zip decorative su base, braccioli e schienale disponibili in finitura oro, ottone anticato e nickel nero. Rete a doghe in legno, supporto rete costituito da quattro angolari più traversa centrale, regolabili in altezza, in acciaio verniciato. Base in MDF laccato.

Abbinabile a set lenzuola, cuscini e copriletto Sylvia.

Bed upholstered in leather or fabric. Internal structure in solid wood and shaped plywood; padding in polyurethane foam in different densities. Shaped headboard internally finished with padded panels, individually upholstered. Sommier with multi-faceted angles, equipped with bench with seat cushions in polyurethane and Memory Foam® and goose down. Backrest padded in individually upholstered panels. Decorative zipper on base, armrests and backrest available in gold, antiqued brass and black nickel. Wooden slats with 4 angle supports and a central bar, adjustable in height, in varnished steel. Base in lacquered MDF.

Shown with bed linings, pillows and bedcover Sylvia.

vedi anche/see also HEMINGWAY divano, poltrona-sofa, armchair, HEMINGWAY turca-ottoman, HEMINGWAY panca alta-high bench

● click here

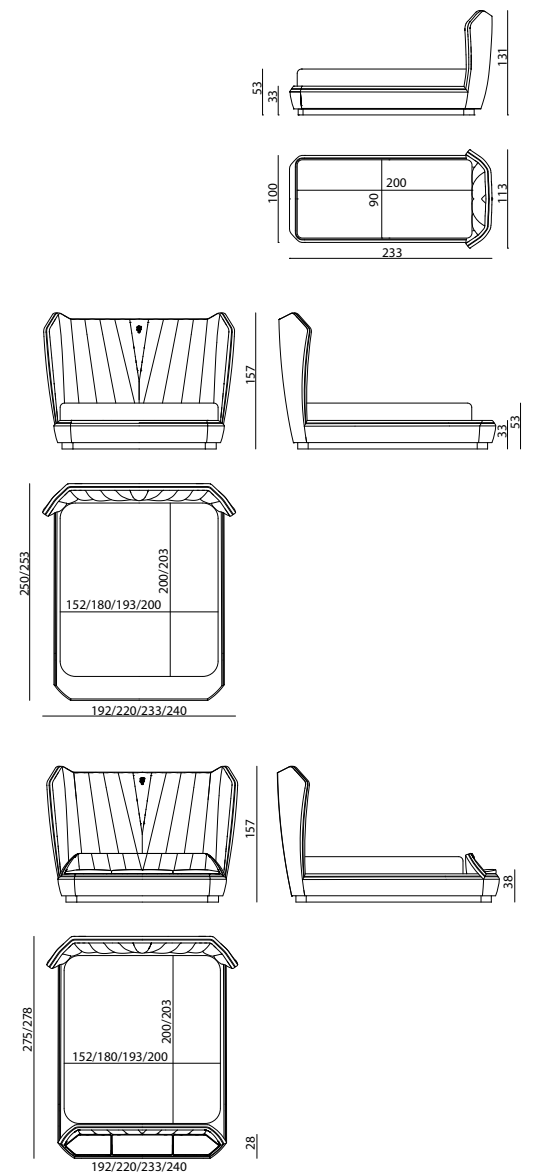



LE COMTE

LETTO - BED

Fabio Bonfà

Letto imbottito in pelle o tessuto. Testata in multistrati curvato e cuscino poggiatesta imbottito in poliuretano. La testata è rivestita in pelle o tessuto con logo ricamato e cuscino interno poggiatesta rivestito a contrasto. Bordo di finitura della testata in alluminio lucido, sommier in multistrati di legno diviso in tre parti, rivestito in pelle o tessuto con bordi inferiore e superiore rivestiti a contrasto. Piedi e profilo testata in alluminio. Le parti metalliche sono disponibili nelle finiture metalliche oro e cromo. Abbinabile alle reti a doghe in legno e materassi Visionnaire. Supporti della rete regolabili in altezza.

Padded bed in leather or fabric. Headboard in curved plywood and headrest cushion padded with polyurethane foam. Headrest upholstered in leather or fabric decorated with embroidered logo and pillow inside the headrest provided with contrasting upholstery. Headboard decorative profile in polished aluminium. Bed frame in wood plywood divided in 3 parts, upholstered in leather or fabric, lower and upper edges with contrasting upholstery. Feet and headboard profiles in aluminium. Metal parts available with chrome or gold finish. Suitable for Visionnaire slats and mattresses. Slats supporting brackets with adjustable height.

vedi anche/see also LE COMTE comodino-bedside table

● click here

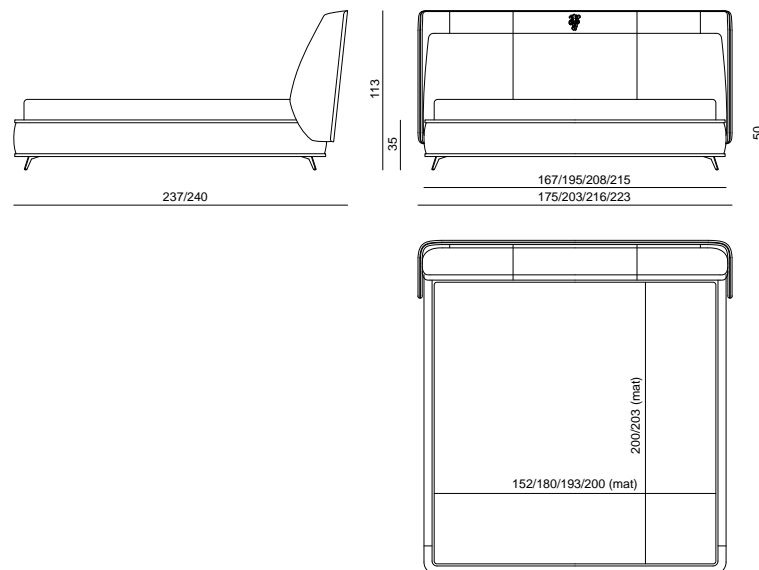

LEONARDO

LETTO - BED

Alessandro La Spada

Letto tappezzato in pelle o tessuto. Struttura testata in multistrati di pioppo e tamponature in compensato. Imbottitura testata in poliuretano di densità 30Kg/m³ con lavorazione a canne d'organo imbottite e rivestite singolarmente. Cornice superiore e zoccolo in acciaio inox ad alto spessore, unite da due profili concavi in acciaio con luce di cortesia a LED con accensione a sfioro. Telaio giroletto in multistrati di pioppo da 25 mm con elementi imbottiti e rivestiti singolarmente. La testata può essere dotata di faretto di lettura a LED opzionali. Supporti per rete angolari regolabili in altezza. Rivestimento di testata e sommier non sfoderabile. Le parti metalliche sono disponibili nella selezione finiture metalliche.

Abbinabile a set lenzuola Vinci.

Bed covered in leather or fabric. Headboard structure in poplar plywood and plywood infills. Headboard padding in polyurethane with 30 kg/m³ density with stovepipe working, padded and covered individually. Upper frame and plinth in thick stainless steel, joined by two steel concave profiles with LED courtesy light with on/off switch device. Bedframe in poplar plywood 25 mm with elements padded and covered individually. The headboard can be equipped with optional LED reading spotlights. Corner supports for wooden slats with height adjustable system. Cover of headboard and bedframe not removable. The metal parts are available in the metal finishes selection.

Shown with Vinci bed complements.

vedi anche/see also LEONARDO comodino-bedside table, LEONARDO cassetiera-chest of drawers, LEONARDO media-high unit, LEONARDO mobile basso-low unit, LEONARDO consolle portalavabo-wellness unit, LEONARDO mobile bar-bar unit, LEONARDO libreria-bookshelf, LEONARDO armadio-wardrobe

● click here

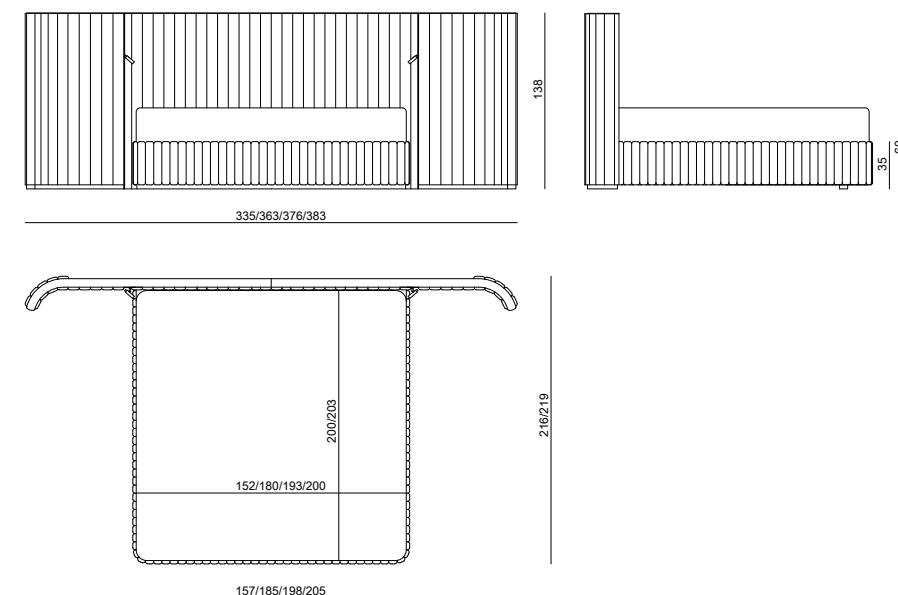



PERKINS

LETTO - BED

La Conca

Letto imbottito in pelle o tessuto, testata formata da fusto in multistrati di pioppo e tessere imbottite e tappezzate singolarmente, a formare un mosaico tridimensionale; bordatura esterna in acciaio lucidato, predisposizione attacco a parete. Sommier con scocca in multistrati imbottito in poliuretano espanso e rivestita in pelle o tessuto, con fregi metallici in acciaio inox lucidato, con logo in ottone. Base in acciaio lucidato. Rete a doghe in legno, supporto rete costituito da quattro angolari più traversa centrale, regolabili in altezza, in acciaio verniciato. Le parti metalliche sono disponibili nella selezione finiture metalliche.

Abbinabile a set lenzuola, cuscini e copriletto Bianca.

Quilted bed upholstered in leather or fabric, headboard made of poplar plywood composed of quilted elements individually upholstered and interwoven so to compose a tridimensional mosaic. Polished steel external outlines. Equipped to be fixed to the wall. Bedframe with matelassé effect upholstery, frame in plywood padded in polyurethane, plinth in satin stainless steel. Available with wooden slats supported by four corner braces and one central rod in lacquered steel, with adjustable heights. Metal components can be finished with any lacquer of the metal lacquer finish selection.

Shown with bed linings, pillows and bedcover Bianca.

vedi anche/see also PERKINS comodino-bedside table, PERKINS cassettera-chest of drawers, PERKINS specchiera-mirror

● click here

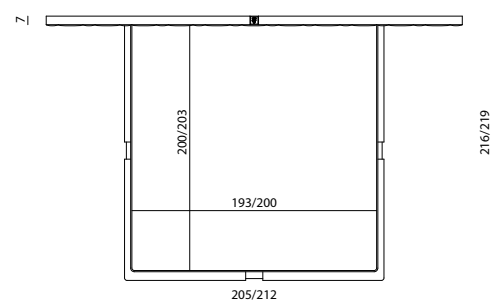
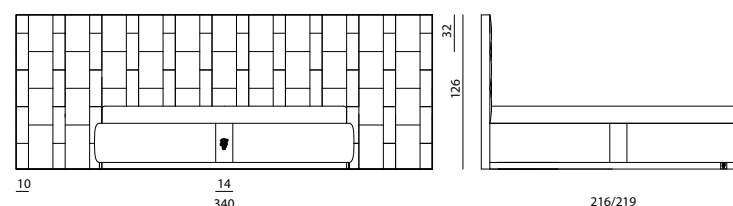
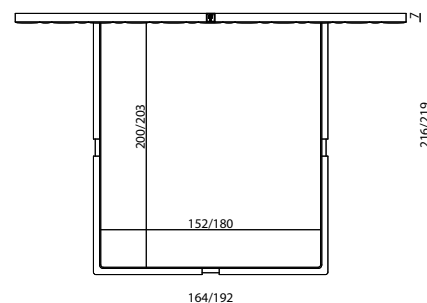
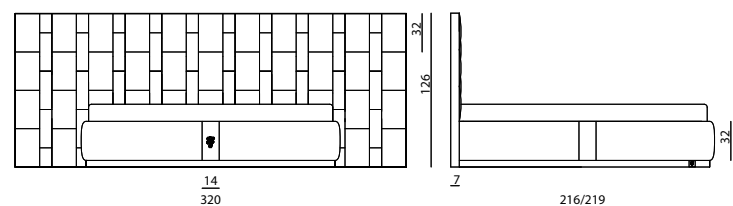

PALAU REGULAR

LETTO - BED

La Conca

Letto tappezzato in pelle o tessuto. Testata composta da guanciali in piuma sostenuti da struttura posteriore in legno a filo del sommier, rivestita in pelle o tessuto. Sommier tappezzato a effetto matelassé, con struttura interna in legno multistrati imbottito in poliuretano e base in acciaio inox satinato. Disponibile con rete a doghe in legno supportata da quattro angolari più traversa centrale, regolabili in altezza, in acciaio verniciato. Le parti decorative in metallo sono disponibili nella selezione finiture metalliche.

Abbinabile a set lenzuola, cuscini e copriletto Ernon.

Bed upholstered in leather or fabric. Headboard consisting of pillows in feather, supported by a wooden structure as large as the bedframe, upholstered in leather or fabric. Bedframe with matelassé effect upholstery, frame in plywood padded in polyurethane, plinth in satin stainless steel. Available with wooden slats supported by four corner braces and one central rod in lacquered steel, with adjustable heights. Metal components can be finished with any lacquer of the metal lacquer finish selection.

Shown with bed linings, pillows and bedcover Ernon.

vedi anche/see also PALAU comodino-bedside table

● click here

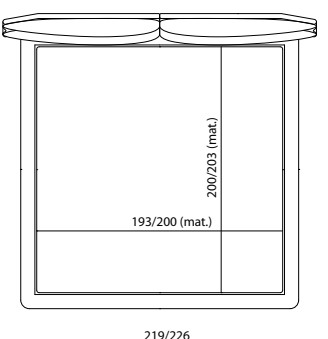
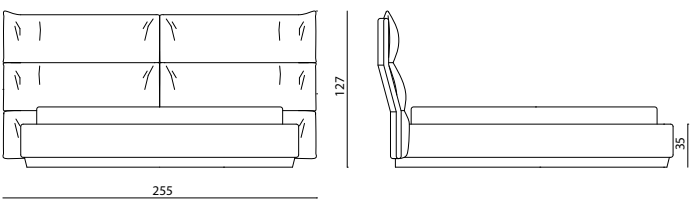
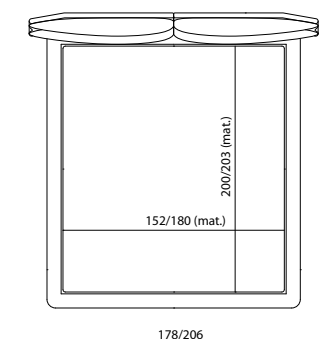
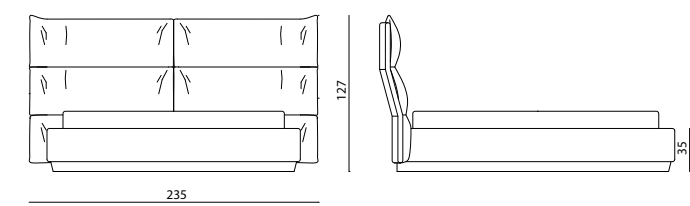



PLAZA

LETTO - BED

Mauro Lipparini

Letto tappezzato in pelle o tessuto, testata in due parti con struttura in multistrati imbottito in poliuretano espanso, rivestimento liscio oppure assemblato con motivo geometrico, elementi decorativi laterali in acciaio inox curvo satinato. Parte centrale con grande cuscino in poliuretano e falda acrilica fissato con zip. Sommier in legno con zoccolo sagomato in acciaio inox satinato e struttura superiore leggermente imbottita e rivestita in raso ospitante un materassino di supporto. Le parti in metallo sono disponibili nella selezione finiture metalliche satinato. Disponibile in opzione luce di cortesia a LED sotto il sommier. Predisposto per attacco a parete.

Abbinabile a set lenzuola, cuscini e copriletto Pacific.

Bed upholstered in leather or fabric; headboard divided in 2 parts with plywood structure padded in polyurethane foam, upholstered plain or assembled with geometrical pattern. Decorative lateral elements in curved satinized stainless steel. Central part with cushion in polyurethane and acrylic fibre with zip closure. Wooden sommier with shaped plinth in satinized stainless steel and upper part slightly padded and upholstered in satin, equipped with a supporting mattress. Metal parts available in the satinized metal finishing selection. Courtesy LED light under the sommier also available. Predisposed for wall fixing.

Shown with bed linings, pillows and bedcover Pacific.

[click here](#)

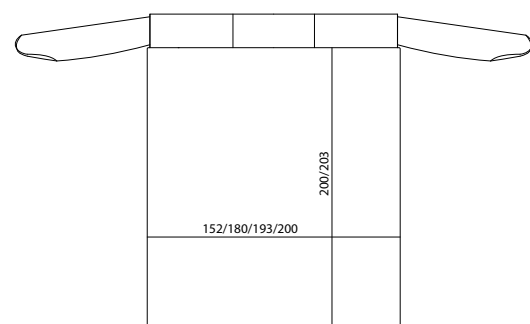
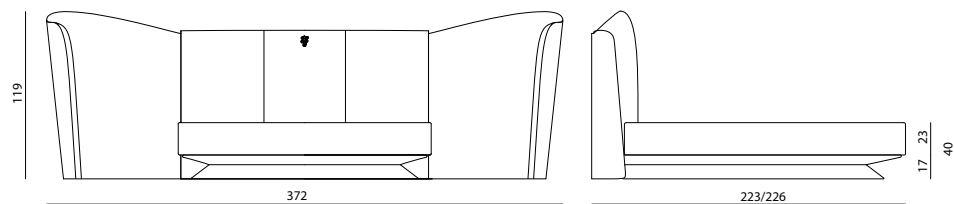
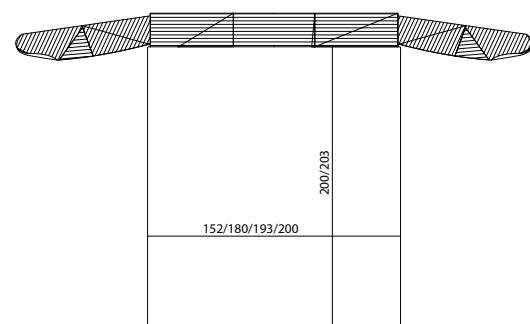
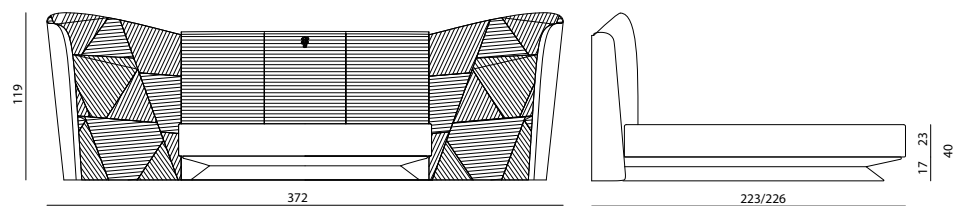

PORFIRIO

LETTO - BED

Roberto Lazzeroni

Testata: struttura in tamburato di multistrato di pioppo da mm 25 con tamponature in compensato da mm 4. Bordatura a fascia larga in massello di faggio laccato lucido. Imbottitura in poliuretano D. 40 kg/m³ con ricopertura in lastra D. 30 kg/m³. Base in legno rivestito in lamina di acciaio. Tappezzeria realizzata con trapuntatura a fasce verticali con supporto in lastra da mm 20 in poliuretano Memory Foam[®]. Giroletto: in multistrati di pioppo da mm 25 tamburato con compensato da mm 4 e imbottitura in poliuretano D. 40 kg/m³. Tappezzeria realizzata con trapuntatura a fasce verticali con supporto in lastra da mm 20 in poliuretano Memory Foam[®]. Base in MDF laccato lucido su zoccolo in legno rivestito in lamina di acciaio inox lucido. Quattro angolari e una traversa centrale, in acciaio verniciato, costituiscono la ferramenta in dotazione per l'assemblaggio del giroletto e relativo ancoraggio alla testata e quale sostegno, regolabile in altezza, di un piano letto con rete a doghe.

Abbinabile a set lenzuola, cuscini e copriletto Porfirio.

Headboard: structure in poplar honeycomb plywood mm 25 with plywood fillers mm 4. Large band border in polished lacquered beech solid wood. Padding in polyurethane D. 40 kg/m³ with cover in layer D. 30 kg/m³. Wooden base covered by steel laminate. Upholstery made with vertical quilting with support in Memory Foam[®] polyurethane layer mm 20. Bedframe: in poplar multiply wood mm 25 honey-combed with plywood mm 4 and padding in polyurethane D. 40 kg/m³. Upholstery made with vertical quilting with support in Memory Foam[®] polyurethane layer mm 20. Base in polished lacquered MDF on wooden plinth covered with polished stainless steel laminate. Four angled corner supports and a central crossbar, in painted steel, make up the hardware included for assembly of the bed perimeter and relative fixing to the headboard for support, adjustable in height for the slats which determine the bed level.

Shown with bed linings, pillows and bedcover Porfirio.

[click here](#)

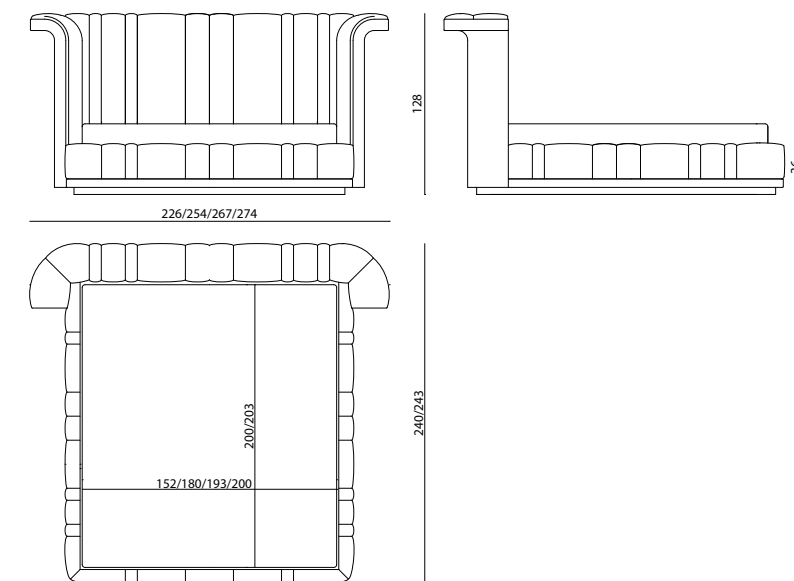



PRINCESS

LETTO - BED

Steve Leung

Letto tappezzato in pelle o tessuto. Struttura del sommier in legno massello di faggio scolpito e rivestito in pelle con piedi sagomati conici con puntale metallico satinato. Testata tappezzata in pelle nella parte centrale con lavorazione a plissettature ribattute ed in pelle o tessuto nelle parti laterali. Imbottitura in poliuretano a densità differenziate. Le pelli disponibili sono: Nabuk, Soft leather, Malta, Sherwood, Classic. Le parti metalliche sono disponibili nella selezione finiture metalliche satiniate.

Abbinabile a set lenzuola, cuscini, copriletto e fondo letto Solange.

Bed upholstered in leather or fabric. Bedframe structure in ash solid wood carved and upholstered in leather with conic-shaped feet with satinized metal tips. Headboard with central part upholstered in leather, quilted with pleated decoration, and lateral parts upholstered in leather or fabric. Padding in polyurethane with different densities. Leathers available: Nabuk, Soft, Malta, Sherwood, Classic. Satinized metal parts available in the metal finishing selection.

Shown with bed linings, pillows, bedcover and throw: Solange.

vedi anche/see also PRINCESS panca-bench

[click here](#)

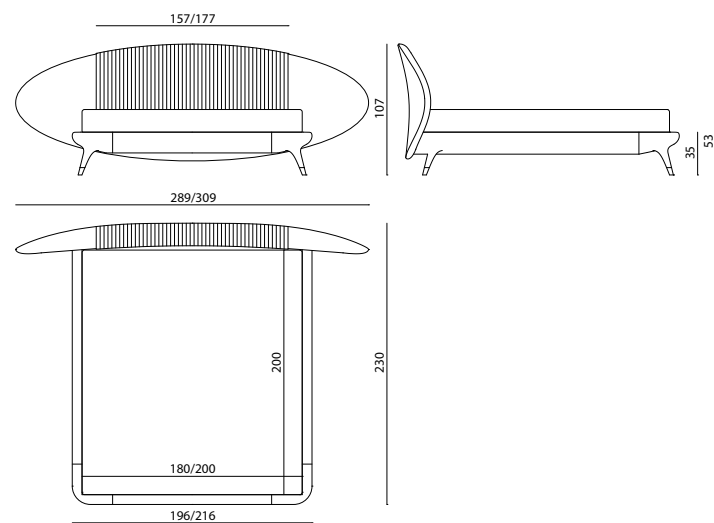

RÊVERIE

LETTO - BED

Roberto Lazzeroni

Letto imbottito in pelle o tessuto con testata alta divisa in due sezioni orizzontali a diversa inclinazione. La parte esterna può essere rivestita in contrasto con la parte interna, divisa da un filetto in pelle. Sommier imbottito con giroletto inclinato verso l'interno e basamento in legno laccato lucido con angolari decorativi in ottone satinato. Struttura interna in masselli e multistrati di legno, rete a doghe in legno massello. Supporti rete/materasso regolabili in altezza. Le parti in metallo sono disponibili nella selezione finiture metalliche.

Disponibile in versione RÊVERIE RADICA con scocca esterna della testata in radica in finitura lucida 100 gloss.

Abbinabile a set lenzuola, cuscini e copriletto Chambre Cinq.

Upholstered bed in leather or fabric with high head divided into two horizontal sections with different inclination. The external part can be covered in contrast with the inner part, divided by a leather thread. Padded sommier with inwardly inclined bed frame; polished lacquered wooden base with decorative satin brass corners. Internal structure in solid and multilayer wood, solid wood slatted base. Height adjustable slats/mattress supports. Metal parts available in the metal finishing selection.

Available in RÊVERIE RADICA version with burr walnut outer shell in 100 gloss finish.

Shown with bed linings, pillows and bedcover: Chambre Cinq.

[click here](#)

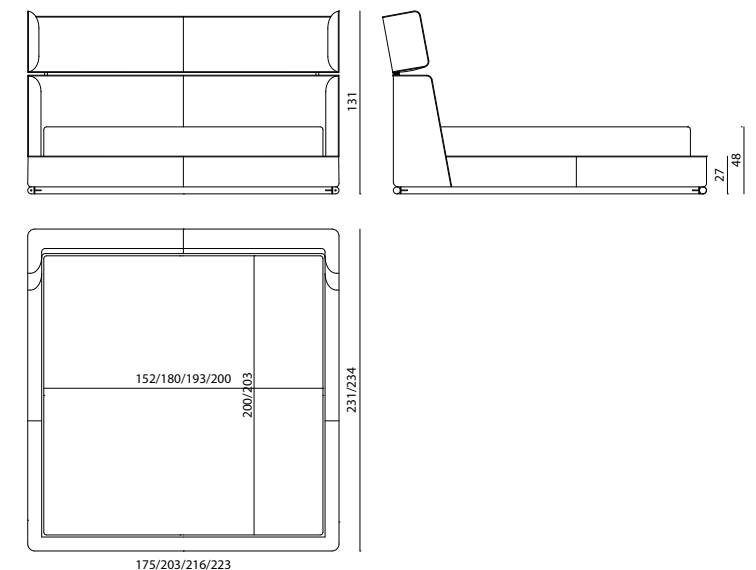
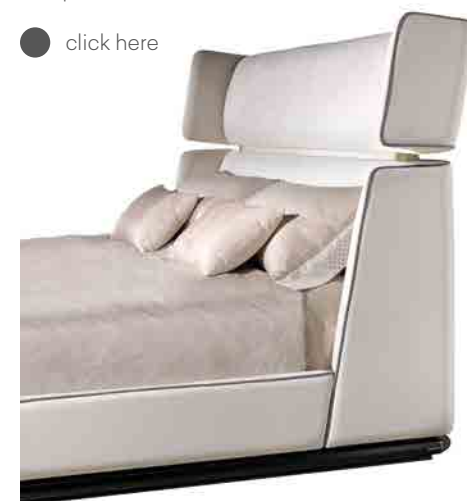

VERSIONE RADICA/ RADICA VERSION



ULTRASOUND LARGE

LETTO - BED

Alessandro La Spada

Letto imbottito in pelle o tessuto, testata formata da fusto in multistrati di pioppo e fasce imbottite e tappezzate singolarmente, a formare un motivo tridimensionale ad alto spessore completato da fregi metallici in acciaio inox lucidato. Predisposizione per attacco a parete. Sommier con scocca in legno multistrati imbottito in poliuretano e motivo trapuntato. Letto consegnabile smontato. Zoccolo di base in acciaio lucidato. Rete a doghe in legno, supporto rete costituito da quattro angolari metallici e traversa centrale, regolabili in altezza. Le parti in metallo sono disponibili nella selezione finiture metalliche.

Abbinabile a set lenzuola, cuscini e copriletto Techno.

Bed upholstered in leather or fabric, headboard composed by a structure in poplar plywood and bands padded and upholstered one by one, creating a three-dimensional pattern decorated with polished stainless steel friezes. To be wall mounted. Bed frame with structure in plywood, padded in polyurethane foam and decorated with quilting. Bed can be provided disassembled. Plinth in polished stainless steel. Wooden slats supported by four corner brackets and one central rod, with adjustable height. The metal parts are available with any finish included in the metal finish selection.

Shown with bed linings, pillows and bedcover Techno.

vedi anche/see also ULTRASOUND comodino-bedside table

● click here

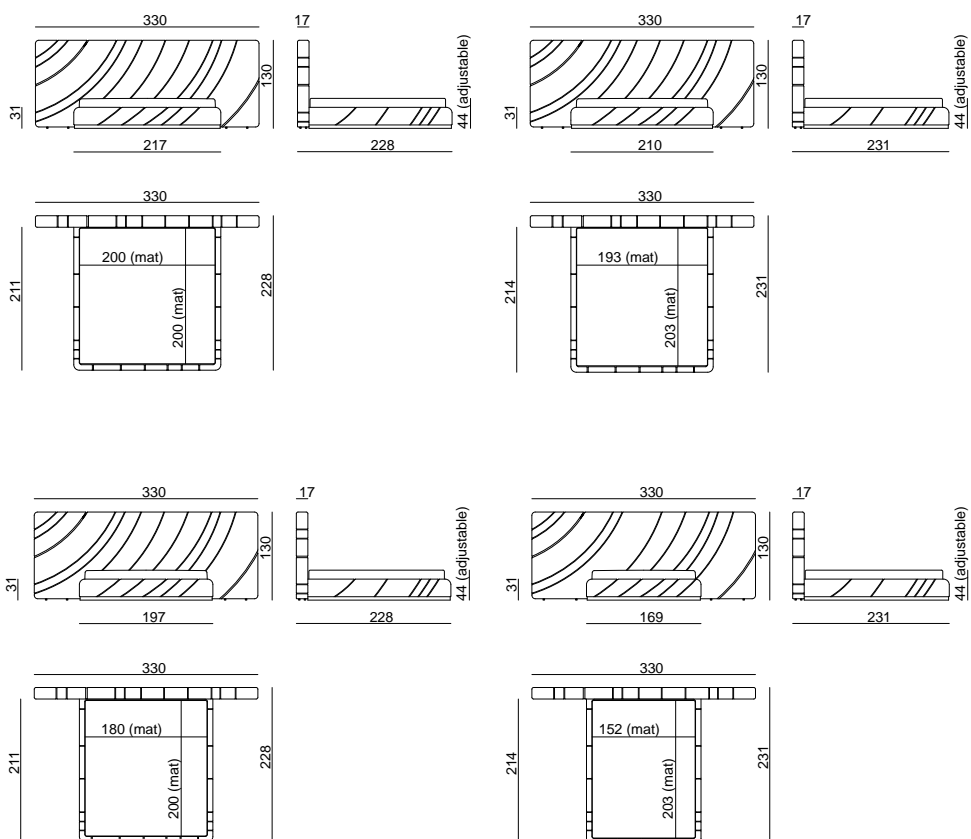

ULTRASOUND REGULAR

LETTO - BED

Alessandro La Spada

Letto imbottito in pelle o tessuto, testata formata da fusto in multistrati di pioppo e fasce imbottite e tappezzate singolarmente, a formare un motivo tridimensionale ad alto spessore completato da fregi metallici in acciaio inox lucidato. Predisposizione per attacco a parete. Sommier con scocca in legno multistrati imbottito in poliuretano e motivo trapuntato. Letto consegnabile smontato. Zoccolo di base in acciaio lucidato. Rete a doghe in legno, supporto rete costituito da quattro angolari metallici e traversa centrale, regolabili in altezza. Le parti in metallo sono disponibili nella selezione finiture metalliche.

Abbinabile a set lenzuola, cuscini e copriletto Techno.

Bed upholstered in leather or fabric, headboard composed by a structure in poplar plywood and bands padded and upholstered one by one, creating a three-dimensional pattern decorated with polished stainless steel friezes. To be wall mounted. Bed frame with structure in plywood, padded in polyurethane foam and decorated with quilting. Bed can be provided disassembled. Plinth in polished stainless steel. Wooden slats supported by four corner brackets and one central rod, with adjustable height. The metal parts are available with any finish included in the metal finish selection.

Shown with bed linings, pillows and bedcover Techno.

vedi anche/see also ULTRASOUND comodino-bedside table

● click here

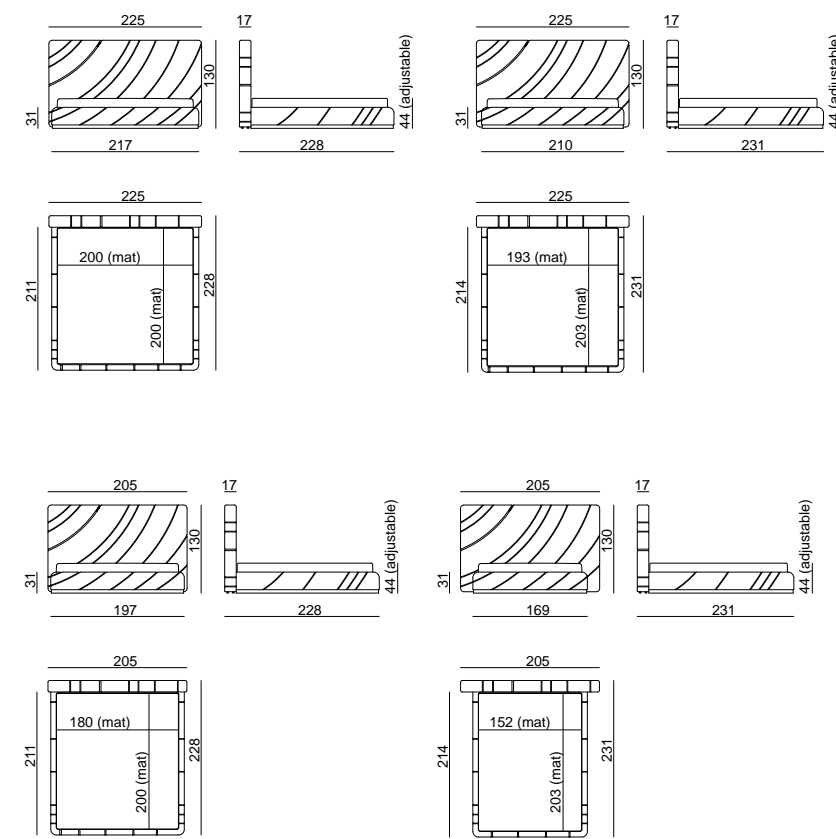



RIPLEY

LETTO - BED

Fabio Bonfà

Letto imbottito con testata trapuntata in pelle o tessuto, incorniciata da un profilo in legno rivestito in pelle o tessuto rifinito con un profilo in ottone. Fianchi della testata incassati nella cornice rivestiti in pelle o tessuto intrecciati, leggermente imbottiti. Disponibile con luce di cortesia a LED sui fianchi della testata con interruttori a sfioramento. Sommier in pelle o tessuto intarsiato con profili in ottone sul perimetro del giroletto. Struttura interna in masselli e multistrati di legno, rete a doghe in legno massello. Supporti rete e materasso regolabili in altezza.

Abbinabile a set lenzuola, cuscini e copriletto Epoque.

Upholstered bed with quilted headboard in leather or fabric, framed by a wooden profile covered in leather or fabric with a brass profile. Headboard sides embedded in the frame covered in leather or woven, slightly padded. Available with LED courtesy light on the sides of the head with touch switches. Sommier in leather or fabric inlaid with brass profiles around the bed frame. Internal structure in solid and multilayer wood, solid wood slatted base. Height adjustable slats/mattress supports.

Shown with bed linings, pillows and bedcover: Epoque.

[click here](#)



VERSIONE LARGE - LARGE VERSION

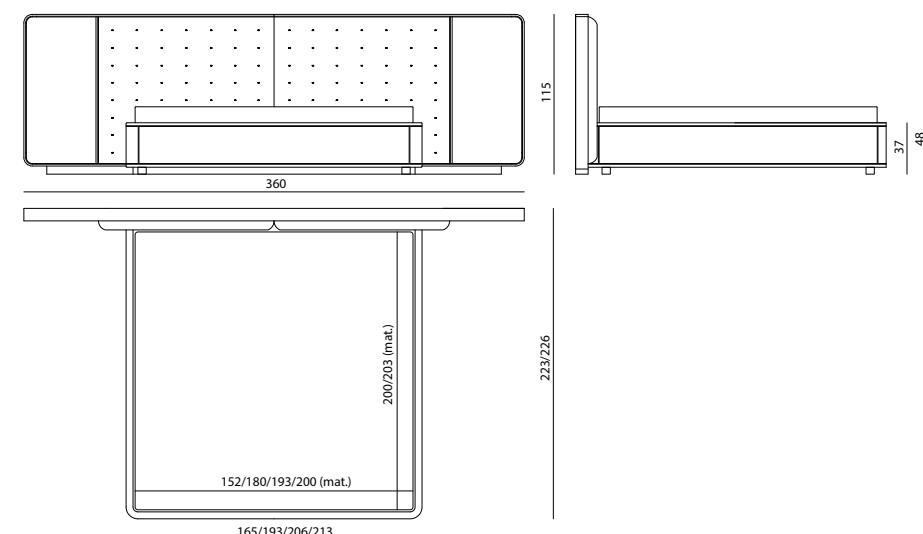

VERSIONE REGULAR - REGULAR VERSION

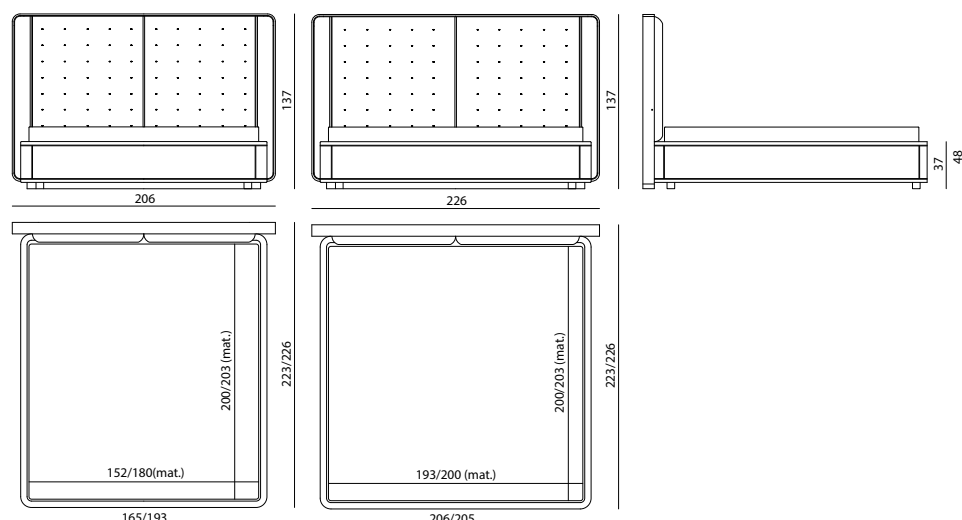



BRADLEY

LETTO - BED

Giuseppe Viganò

Testata con struttura in multistrati sagomati, con pannelli imbottiti in poliuretano e tappezzati in pelle o tessuto, bordo testata e basamento in acciaio inox lucidato, predisposizione attacco a parete. Sommier imbottito in poliuretano espanso e rivestito in pelle o tessuto. Rete a doghe in legno, supporto rete costituito da quattro angolari più traversa centrale, regolabili in altezza, in acciaio verniciato. Le parti in metallo sono disponibili nella selezione finiture metalliche.

Abbinabile a set lenzuola, cuscini e copriletto Koralyñ.

Headboard with shaped plywood structure, quilted panels in polyurethane and upholstered in fabric or leather, headboard frame and base in polished stainless steel. Headboard predisposed for wall fixing ready. Wooden slats with four angles support and central bar, adjustable in height, in varnished steel. Metal parts available in the metal finishing selection.

Shown with bed linings, pillows and bedcover Koralyñ.

vedi anche/see also BRADLEY comodino-bedside table

click here

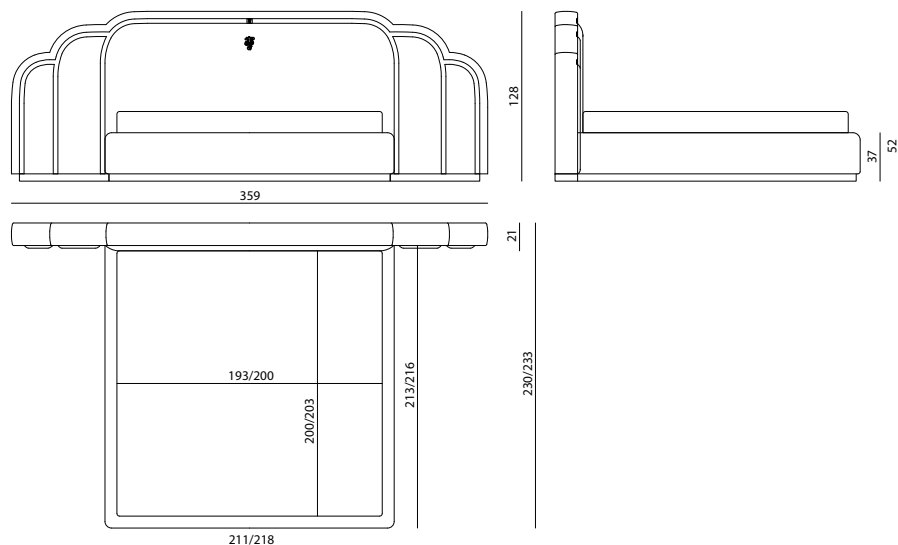
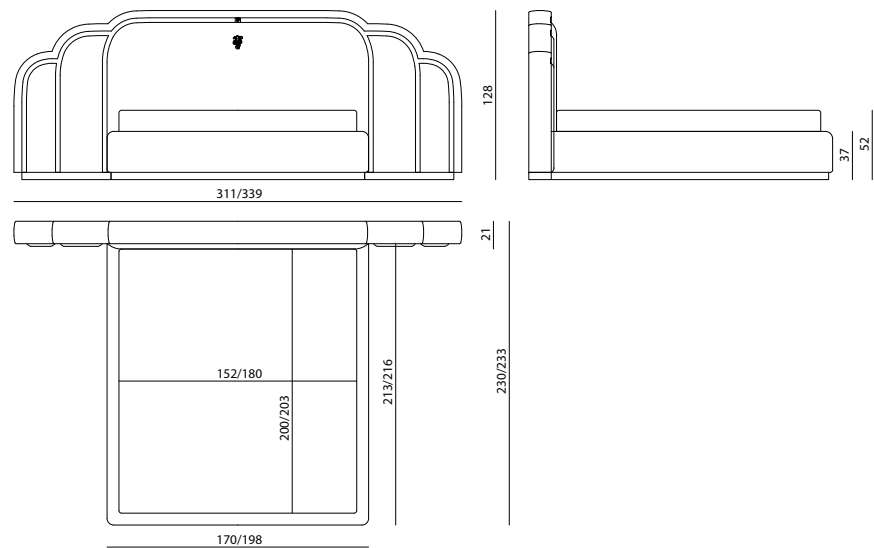

WOTTON BELT

LETTO - BED

Alessandro La Spada

Letto imbottito e rivestito in pelle o tessuto. Struttura della testata e della pediera in multistrati di pioppo imbottito in poliuretano espanso con loghi ricamati. Longoni laterali in metallo rivestiti con una cover in MDF e tappezzati in pelle o tessuto. Gambe in metallo tappezzate e decorate con bracciali e pomoli in alluminio tornito. Loghi in ottone inciso. Supporto rete formato da quattro angolari più una traversa centrale, senza possibilità di regolazione in altezza. Le parti in metallo sono disponibili nella selezione finiture metalliche. Disponibile versione letto con pediera alta o bassa. Versione BELT: profili rivestiti in pelle, fissati con borchie.

Abbinabile a set lenzuola, cuscini e copri-piumino Bolero.

Quilted bed upholstered in leather or fabric. Headboard and footboard structure poplar plywood padded with polyurethane. Embroidered logos. On the sides long metallic stripes covered by MDF and upholstered in leather or fabric. Metallic legs upholstered and decorated with turned aluminium rings and knobs. Brass engraved logos. Wooden slats support with four angles support and central bar, not adjustable in height. Metal parts available in the metal finishing selection. Available also in the version with high or low footboard. Version BELT: upholstered in leather, fixed with studs.

Shown with bed linings, pillows and duvet cover Bolero.

click here

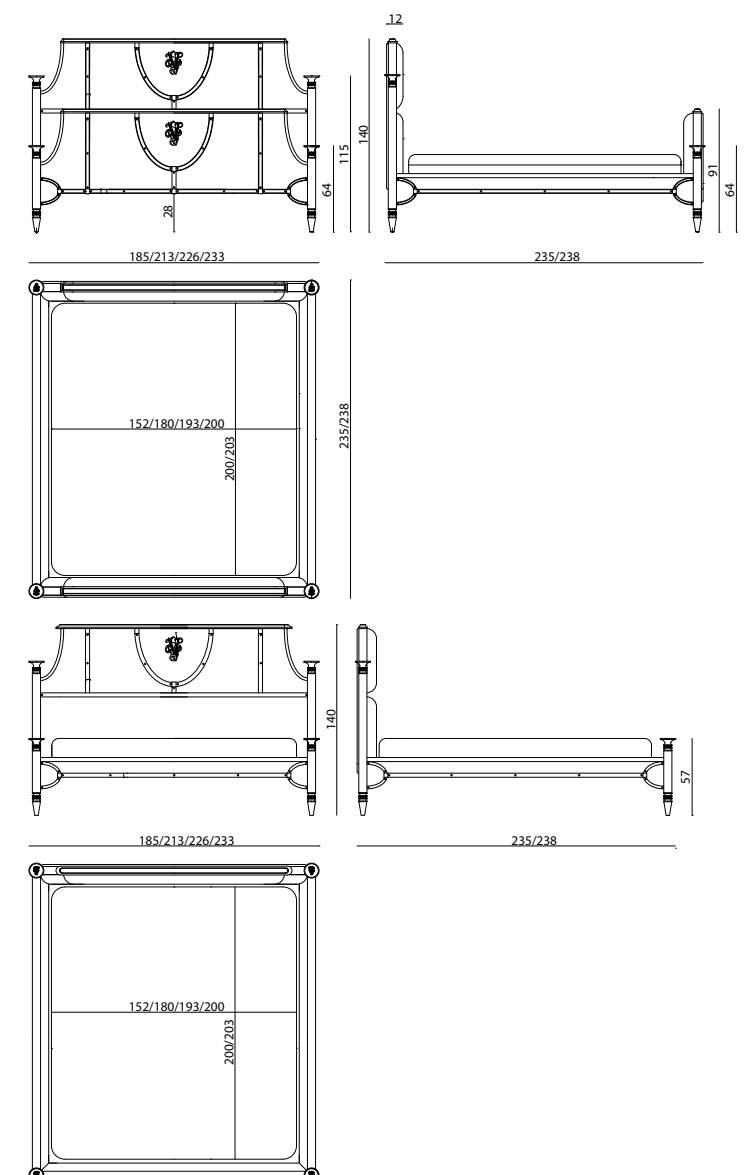



WOTTON METAL

LETTO - BED

Alessandro La Spada

Letto imbottito e rivestito in pelle o tessuto. Struttura della testata e della pediera in multistrati di pioppo imbottito in poliuretano espanso con loghi ricamati. Longoni laterali in metallo rivestiti con una cover in MDF e tappezzati in pelle o tessuto. Gambe in metallo tappezzate e decorate con bracciali e pomoli in alluminio tornito. Loghi in ottone inciso. Supporto rete formato da quattro angolari più una traversa centrale, senza possibilità di regolazione in altezza. Le parti in metallo sono disponibili nella selezione finiture metalliche. Disponibile versione letto con pediera alta o bassa. Versione METAL: decorazione profili in ottone cromato.

Abbinabile a set lenzuola, cuscini e copriletto Viola.

Quilted bed upholstered in leather or fabric. Headboard and footboard structure poplar plywood padded with polyurethane. Embroidered logos. On the sides long metallic stripes covered by MDF and upholstered in leather or fabric. Metallic legs upholstered and decorated with turned aluminium rings and knobs. Brass engraved logos. Wooden slats support with four angles support and central bar, not adjustable in height. Metal parts available in the metal finishing selection. Available also in the version with high or low footboard. Version METAL: decorated with chromed brass outlines.

Shown with bed linings, pillows and bedcover Viola.

[click here](#)

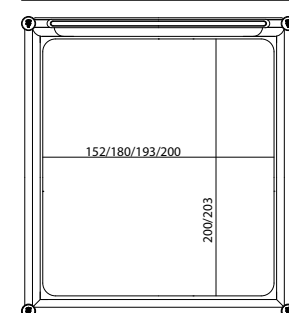
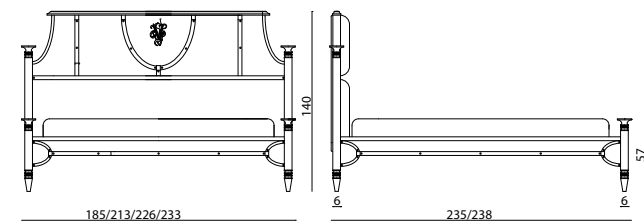
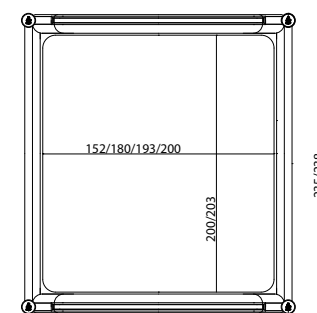
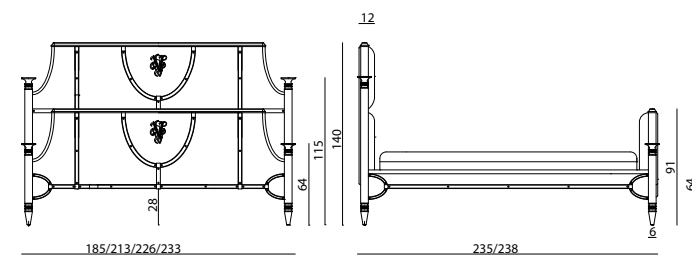

- click on the icons -



AUBADE p.180



BEAUFORTS p.180



BELOVED p.181



CA' FOSCARI p.181



LE COMTE p.182



LEONARDO p.182



NOMOS p.183



PALAU p.183



PERKINS p.184



RONDÒ p.184



SKIBA p.185



ULTRASOUND p.185



WILLIAMS p.186



ZENIT p.186

ICONICI - *ICONIC*



ALICE p.188



BECKY p.188



BRADLEY p.189



NOTTINGHAM p.189



AUBADE

COMODINO - BEDSIDE TABLE
Alessandro La Spada

Comodino rivestito in pelle o tessuto. Struttura in multistrati, con cassetto indipendente e top in specchio fumé leggermente incassato, contenuto in un vano a giorno. Cornice e base in acciaio inox. Il vano a giorno è servito da luce di cortesia a LED. Lo schienale del vano a giorno è rivestito in pelle o tessuto, oppure in opzione con inserto in marmo. Le parti in metallo sono disponibili nella selezione finiture metalliche.

Bedside table upholstered in leather or fabric. Structure in multiply wood with separate drawer and top in smoked mirror glass slightly built in and contained in an open compartment. Frame and base in stainless steel. The open compartment is provided with a LED courtesy light. The back of the open compartment is upholstered in leather or fabric, or optionally with a marble insert. The metal parts are available in the metal finishes selection.

vedi anche/see also AUBADE letto-bed

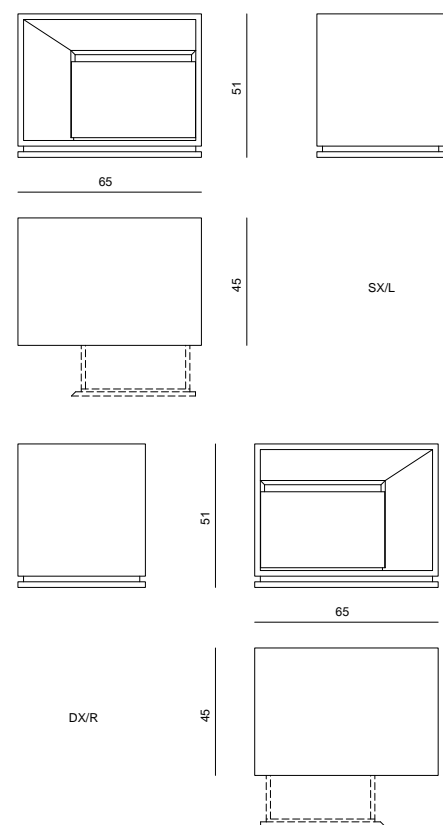

BEAUFORTS

COMODINO - BEDSIDE TABLE
Maria Serebryanaya

Comodino ellittico. Struttura in MDF laccato lucido con 2 cassetti. Top scorrevole lateralmente. Maniglia ovale in acciaio finitura lucida. Profilatura zoccolo di base in acciaio finitura cromo lucido. Le parti in metallo sono disponibili nella selezione finiture metalliche.

Elliptical bedside table. Structure in MDF shiny lacquered with 2 drawers. Top with sliding system on the side. Oval handle in steel polished finishing. Base plinth in polished chromed steel. Metal parts available in the metal finishing selection.

● click here

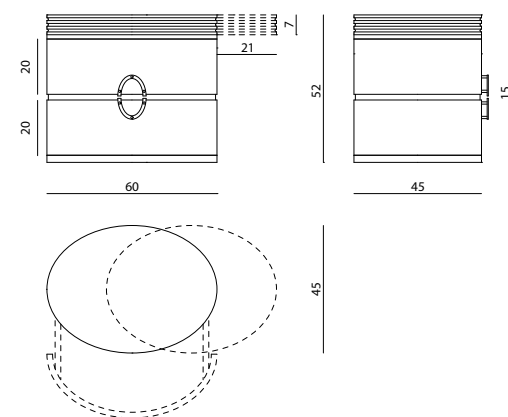

BELOVED

COMODINO - BEDSIDE TABLE
Alessandro La Spada

Comodino tappezzato con trama geometrica. Struttura in multistrati, cassetto imbottito in poliuretano tappezzato con pannelli leggermente imbottiti rivestiti singolarmente in pelle o tessuto. Inserto in acciaio inox satinato con logo inciso. Vano a giorno servito da luce di cortesia a LED. Il bordo del vano è incorniciato da un telaio in acciaio inox. Zoccolo in acciaio inox satinato. Le parti in metallo sono disponibili nella selezione finiture metalliche.

Bedside table upholstered creating a geometrical pattern. Structure in plywood, drawer padded in polyurethane, finished in slightly padded panels individually upholstered in leather or fabric. Insert in satinized stainless steel with engraved logo. Open shelf with courtesy LED light; edge with frame in polished stainless steel. Plinth in satinized stainless steel. Metal parts available in the metal finishing selection.

vedi anche/see also BELOVED letto-bed, BELOVED ART letto-bed

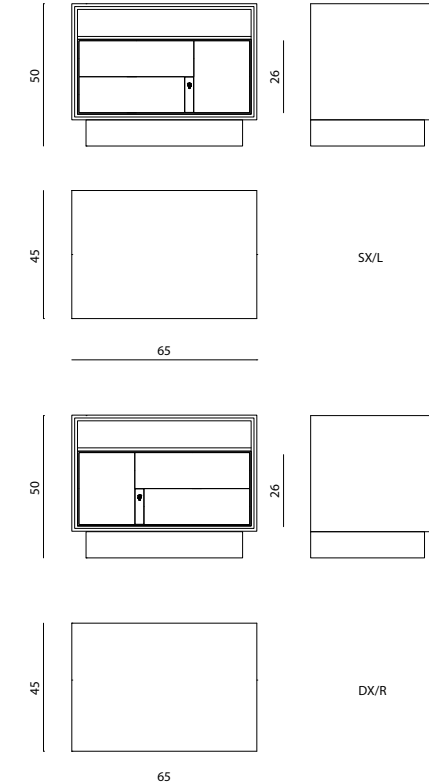

CA' FOSCARI

COMODINO - BEDSIDE TABLE
Alessandro La Spada

Comodino in legno con fianchi concavi in essenza o laccati a finitura manuale lucida 100 gloss. Cornice interna in acciaio inox curvato. Cassetto con frontale rivestito in pelle o tessuto laccato internamente RAL/NCS opaco. Le parti in metallo sono disponibili nella selezione finiture metalliche, le parti in legno sono disponibili nella selezione finiture essenze oppure verniciate in colori RAL/NCS.

Bedside table in wood with concave sides finished with veneered wood or 100 gloss hand-polish lacquer. Internal frame in curved stainless steel. Drawer front upholstered in leather or fabric with internal parts finished with matt RAL/NCS lacquer. Metal parts can be finished in any lacquer of the metal lacquer finish selection. Wooden parts can be finished with any wood veneer of the veneer finish selection or with RAL/NCS lacquer.

vedi anche/see also CA' FOSCARI divano, poltrona-sofa, armchair, CA' FOSCARI letto-bed

● click here

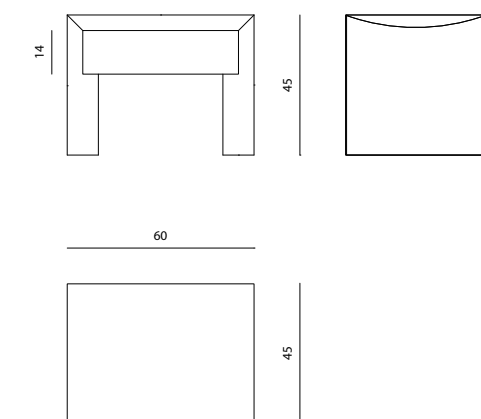



LE COMTE

COMODINO - BEDSIDE TABLE

Fabio Bonfà

Comodino ovale con cassetto. Scocca in MDF sagomato laccato lucido (colori RAL/NCS), cassetto e bordo del top rivestiti in pelle o tessuto a contrasto. Top incassato in marmo lucidato. Il cassetto monta guide a rientro smorzato.

Oval bedside table with drawer. External frame in shaped MDF lacquered with polished finish (RAL/NCS colours), drawer and top edge covered in contrasting leather or fabric. Built-in top in polished marble. Drawer with damped hinges.

vedi anche/see also LE COMTE letto-bed

● click here

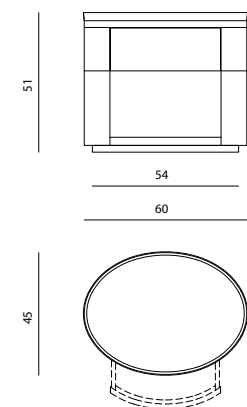

LEONARDO

COMODINO - BEDSIDE TABLE

Alessandro La Spada

Comodino con cassetto, struttura in legno composta da uno zoccolo e un pannello sotto-top rivestiti in acciaio inox lucido curvato in porzioni concave e convesse. Frontale cassetto e fianchi curvi scolpiti con lavorazione superficiale canneté in bassorilievo, disponibili con verniciatura lucida (colori RAL/NCS), nelle vernici metallescenti a campionario, oppure rivestiti in pelle Soft leather. Interni laccati con colori RAL/NCS opaco. I profili decorativi in acciaio inox curvato sono disponibili nella selezione finiture metalliche. Top in appoggio in marmo lucidato con profilo inferiore bisellato.

Bedside table with drawer. Structure in wood with plinth and undertop profile covered in polished curved stainless steel, with convex and concave shapes. Front drawer and curved sides decorated with 'canneté' stripes carved in low relief, available with shiny lacquer (RAL or NCS colours) finish or in metal colours as per finishes selection or upholstered in Soft leather. Interiors in matt RAL/ NCS lacquer. Decorative profiles in curved stainless steel, available in the metal lacquer finish selection. Top in polished marble with bevelled lower edge.

vedi anche/see also LEONARDO letto-bed, LEONARDO cassettiere-chest of drawers, LEONARDO media-high unit, LEONARDO mobile basso-low unit, LEONARDO consolle portalavabo-wellness unit, LEONARDO mobile bar-bar unit, LEONARDO libreria-bookshelf, LEONARDO armadio-wardrobe

● click here

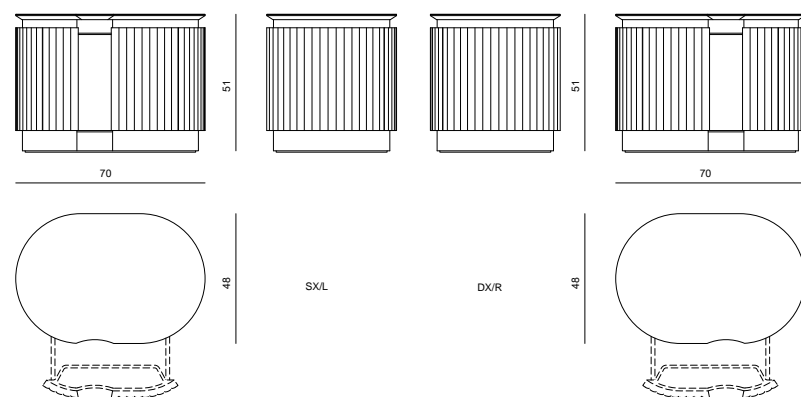

NOMOS

COMODINO - BEDSIDE TABLE

Roberto Lazzeroni

Comodino con 2 cassetti con corpo centrale semi-ellittico in legno curvato su tutti i lati, superficie esterna con profili a rilievo, finitura laccato lucido o rivestito in pelle. Top in marmo inserito in una cornice sagomata in legno massello di rovere con finitura nera a poro aperto. Base conica in legno nero e profilo inferiore in metallo satinato. Interno cassetti in essenza rovere nero e interno in microfibra nera.

Bedside table with 2 drawers with semi-elliptical central body in curved wood on all sides, external surface with raised profiles, glossy lacquered finish or covered in leather. Marble top inserted in a molded frame in solid Oak wood with black open-pore finish. Conical base in black wood and lower profile in satin metal. Drawers interiors in black oak and black microfibre inside.

vedi anche/see also NOMOS mobile alto-cabinet, NOMOS cassettiere-chest of drawers

● click here

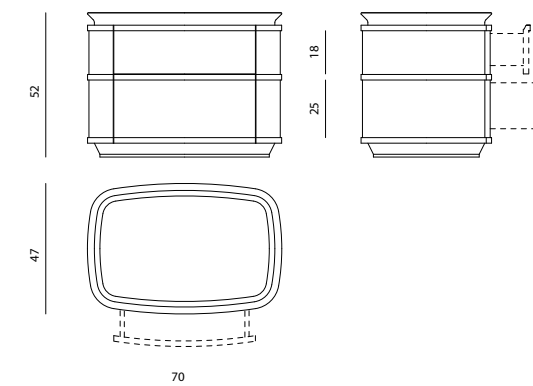

PALAU

COMODINO - BEDSIDE TABLE

Alessandro La Spada

Struttura in MDF con leggera imbottitura. Top in specchio bisellato. Zoccolo di base in legno rivestito in acciaio. Tappetzeria in pelle o tessuto. Interno cassetto rivestito in microfibra. Targhetta in acciaio inox lucido con logo Visionnaire applicata sul frontale del cassetto.

Structure in MDF with light padding. Top in bevelled mirror. Base in wood covered in steel. Upholstery in leather or fabric. Drawer with manual opening and with soft locking system. A plate in polished stainless steel with Visionnaire logo is fixed on the front part of the drawer.

vedi anche/see also PALAU REGULAR letto-bed

● click here

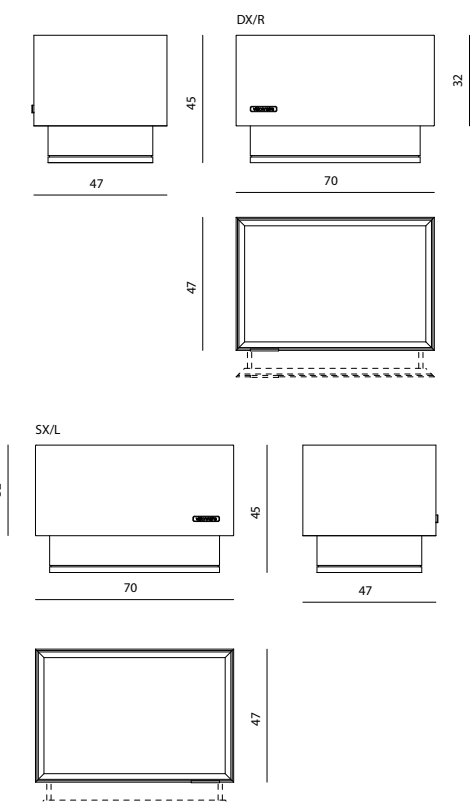



PERKINS

COMODINO - BEDSIDE TABLE

La Conca

Comodino con due cassetti ad apertura push-pull con scocca in multistrati e MDF, imbottita e rivestita in pelle o tessuto. Fregi laterali in acciaio inox lucidato, con logo in ottone. Top in marmo, base in acciaio lucidato. Opzione: maniglia in ottone lucidato con logo in bassorilievo sagomato. Le parti in metallo sono disponibili nella selezione finiture metalliche.

Bedside table with 2 push-pull drawers. Body in multi plywood and MDF, quilted and upholstered in leather or fabric. Polished stainless steel decorations with brass logo on the sides. Top in marble and plinth in polished steel. Polished brass handles with shaped logo in low-relief can be added as optional. Metal parts available in the metal finishing selection.

vedi anche/see also PERKINS letto-bed, PERKINS cassettiera-chest of drawers, PERKINS specchiera-mirror

● click here

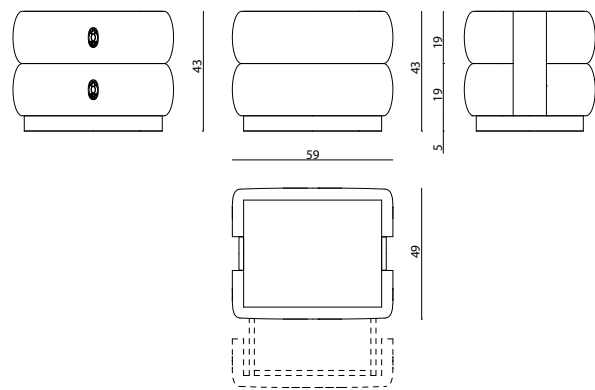
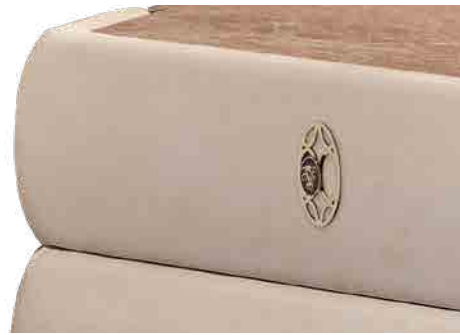

RONDÒ

COMODINO - BEDSIDE TABLE

Roberto Tapinassi - Maurizio Manzoni

Struttura in lamiera acciaio inox spessore mm 3. Cassetto con struttura in legno laccato opaco e frontale in lamiera acciaio inox con decorazione logo Visionnaire in ottone traforato. Top e ripiano di base in vetro retro-laccato, disponibile nei colori di serie, oppure a specchio. Le parti in metallo sono disponibili nella selezione finiture metalliche.

Structure in stainless steel laminate th. mm 3. Drawer with structure in lacquered wood and front in stainless steel laminate, with Visionnaire logo decoration in pierced brass. Top and base in lacquered glass, available in the standard colours or in mirror. Metal parts available in the metal finishing selection.

● click here

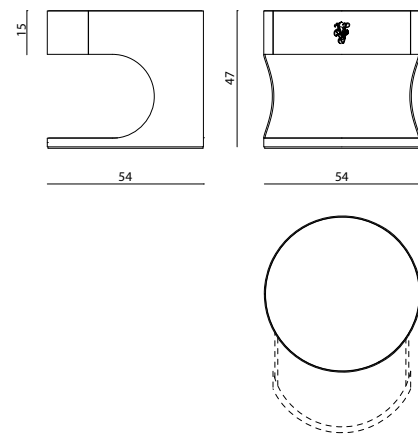

SKIBA

COMODINO - BEDSIDE TABLE

Mauro Lipparini

Comodino tappezzato in pelle o tessuto con un cassetto e vano inferiore a giorno, struttura curva in multistrati leggermente imbottita, cassetto dotato di guide smorzate, interno laccato opaco e frontalino rivestito. Top e ripiano inferiore in specchio bronzo o fumé, oppure in essenza. Base curva in MDF rivestita in acciaio inox satinato. Le parti in metallo sono disponibili nella selezione finiture metalliche.

Bedside table upholstered in leather or fabric with drawer and open lower shelf, slightly padded curved structure in plywood, drawer with damped runners, internal part matt lacquered and upholstered front part. Top and lower shelf in bronze or smoke mirror or in veneered wood. Curved base in MDF, coated in satinized stainless steel. Metal parts available in the metal finishing selection.

● click here

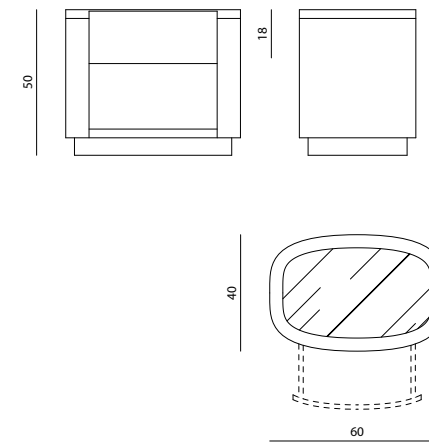

ULTRASOUND

COMODINO - BEDSIDE TABLE

Alessandro La Spada

Comodino tondo con un'anta tappezzata in pelle o tessuto. Scocca in legno multistrati curvato imbottito a fasce diagonali singolarmente tappezzate, zoccolo di base in acciaio lucidato, top in marmo. Interno rivestito in microfibra in tinta con l'esterno, con ripiano di cortesia all'interno dell'anta. Le parti in metallo sono disponibili nella selezione finiture metalliche.

Round bedside table with door upholstered in leather or fabric. Structure in curved plywood with diagonal bands padded one by one, plinth in polished steel, top in marble. Internally covered in microfiber in tone with the external upholstery, internal door provided with courtesy shelf. Metal parts available with any finish included in the metal finish selection.

vedi anche/see also ULTRASOUND LARGE letto-bed, ULTRASOUND REGULAR letto-bed

● click here

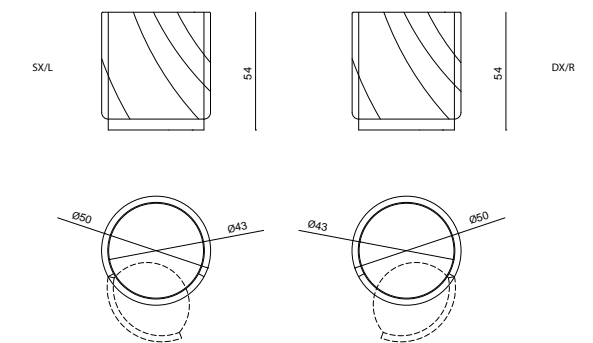



WILLIAMS

COMODINO - BEDSIDE TABLE

Samuele Mazza

Comodino rivestito in specchio bronzo o fumé con top in marmo, servito da un cassetto e vano inferiore a giorno; struttura sfaccettata in MDF rivestita in specchio sia internamente che esternamente; cassetto dotato di guide smorzate con interno in multistrati laccato opaco. Base sfaccettata in legno laccato nero.

Bedside table coated in bronze or smoked mirror with marble top, equipped with drawer and open lower shelf; multi-faceted structure in MDF coated in mirror both internally and externally; drawer runners equipped with damping system; internal part of the drawer in matt lacquered plywood. Multi-faceted base in black lacquered wood.

● [click here](#)



ZENIT

COMODINO - BEDSIDE TABLE

Steve Leung

Comodino interamente rivestito in pelle con top in marmo incassato. Struttura in legno massello con anima metallica. Finiture con cuciture fatte a mano.

Bedside table internally upholstered in leather with built-in marble top. Structure in solid wood with metal frame. Decorated with hand-made stitching.

● [click here](#)

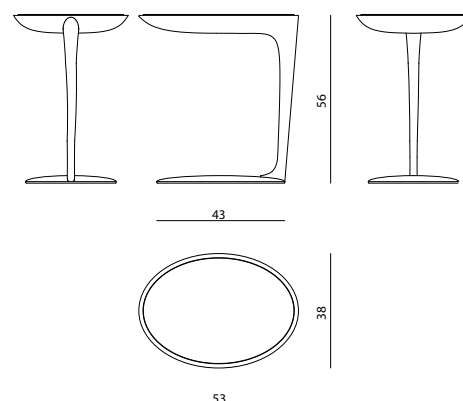
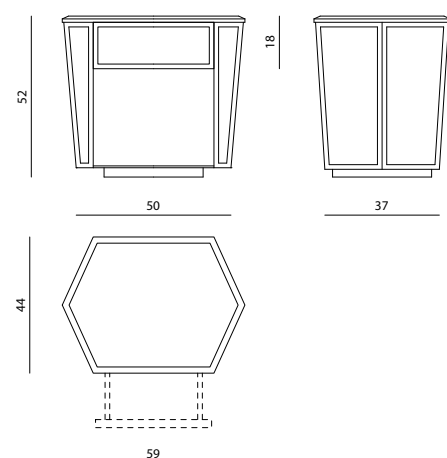



ALICE

COMODINO - BEDSIDE TABLE

Alessandro La Spada

Comodino rivestito con cassetto. Struttura in MDF e multistrato curvato. Zoccolo di base profilato in acciaio inox. Top, cassetto e base laccato lucido. Rivestimento interno ed esterno in pelle o tessuto. Possibilità di trapuntatura interna con ricamo. Maniglia cassetto a scudo in pelle con incisione stemma araldico Visionnaire. Illuminazione di cortesia opzionale.

Upholstered bedside table with drawer. Structure in MDF and curved plywood. Plinth outline in stainless steel. Top, drawer and base in shiny lacquer. Internal and external upholstery in leather or fabric. Optional: internal side quilted with embroidery. Shield handle in leather with Visionnaire coats of arms. Courtesy lights can be applied as optional.

vedi anche/see also ALICE poltrona-armchair, ALICE chaise-longue, ALICE panca-bench, ALICE cassettiere-chest of drawers

● click here

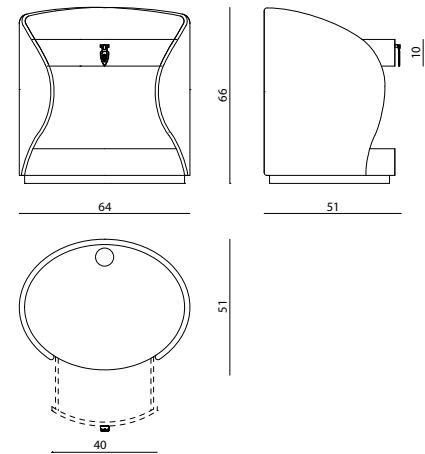

BECKY

COMODINO - BEDSIDE TABLE

Alessandro La Spada

Top in marmo incassato in una cornice bordata in ottone trafilato cromato. Struttura con un cassetto, in legno laccato 100gloss, fregi in acciaio inox lucidato a doppio spessore 3+3 mm, decorazioni delle gambe in alluminio e acciaio laserato. Le parti in metallo sono disponibili nella selezione finiture metalliche.

Top in marble recessed in a bordered chromed and drawn brass frame. Structure with a drawer in 100 gloss lacquered wood. Shiny stainless steel decorations with double thickness 3+3 mm. Aluminium and laser steel legs decoration. Metal parts available in the metal finishing selection.

● click here

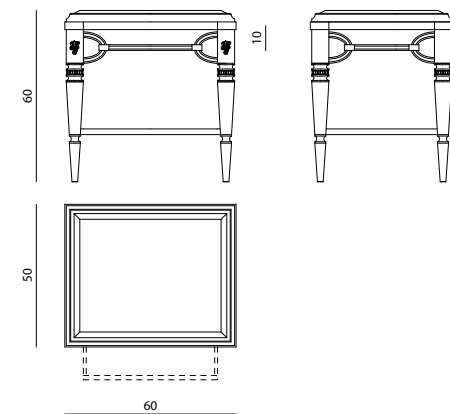

BRADLEY

COMODINO - BEDSIDE TABLE

Giuseppe Viganò

Comodino con 2 cassetti, top in marmo struttura in multistrati curvo leggermente imbottita, rivestimento in pelle o tessuto, interno laccato opaco, cintura e zoccolo in acciaio inox lucido. Le parti in metallo sono disponibili nella selezione finiture metalliche.

Bedside with two drawers, marble top, structure in curved plywood and lightly padded, upholstery in leather or fabric, mat internal lacquering, belt and plinth in polished stainless steel. Metal parts available in the metal finishing selection.

vedi anche/see also BRADLEY panca-bench, BRADLEY letto-bed

● click here

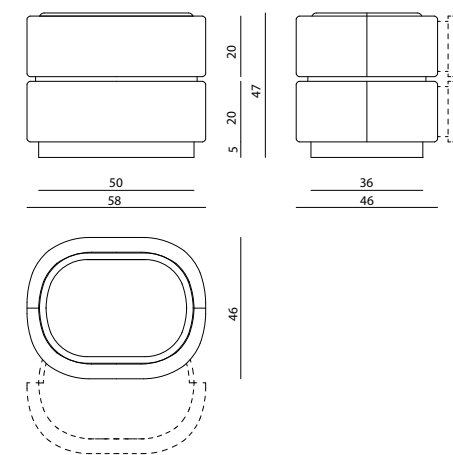

NOTTINGHAM

COMODINO - BEDSIDE TABLE

Samuele Mazza

Comodino con cassetto e vano a giorno con struttura in multistrati curvato. Esternamente tappezzato in tessuto o pelle. Apertura del cassetto con maniglia, a scelta: -G (giglio di Francia) in fusione d'ottone con finitura bronzo anticato oppure argento semilucido; -V in massello di legno con stemma araldico Visionnaire pantografato; -Maniglia a scudo con supporto in metallo e stemma araldico Visionnaire, in acciaio inox, applicato su scudo in cuoio, con finitura patinata a cera, oppure con finitura argento semilucido. Disponibile nella versione con top in vetro o in marmo a incasso.

Bedside table with drawer and open space with structure in curved plywood. Externally covered in fabric or leather. Opening of drawer with handle. Choice of handles: -G (lily of France) in fused brass with antique bronze finish or semilucid silver; -V in solid wood with pantographed Visionnaire coat of arms; -Handles with support in metal and Visionnaire logo in stainless steel on shield in leather, with hand waxed patina finish or with semi-lucid silver finish. Available in the version with glass or built-in marble top.

● click here

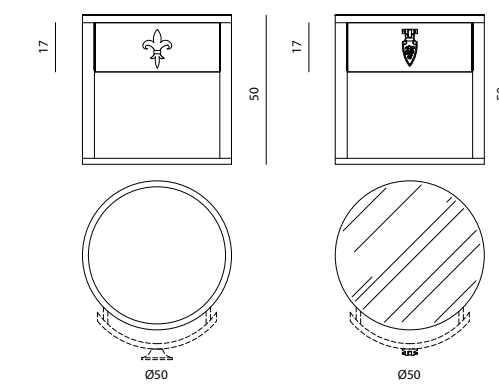

- click on the icons -

- click on the icons -



AMOS p.192



ARKADY p.193



DYLAN 2022 p.194



SOLSTICE p.207



STONE p.208



TEMPTATION p.209



GALITSIN p.195



JASON p.196



KERWAN p.197



THULE p.210



VALIANT p.211



KYLO p.198



LEONARDO p.199



LYRIQUE p.200



MORGAN p.201



OPERA p.202



PALACE p.203



RAIDHO p.204



REVENGE p.205



ROHAN p.206



CHATAM p.212



VERSAILLES p.213



WINDSOR p.214

ICONICI - *ICONIC*



AMOS

TAVOLO DA PRANZO - DINING TABLE

Draga & Aurel

Struttura portante in cemento e alluminio fuso con superficie lucidata e pigmentata a mano. La parte in cemento armato è lavorata con trattamento di erosione e colorazione nero opaco. Top in vetro di spessore 20 mm extra-chiaro molato e sabbato a mano con tecnica ad aerografo, protetto con trattamento anti-macchia. Le parti in alluminio sono disponibili nella selezione finiture metalliche. Peso totale circa 200 kg. Disponibile in versione con top in marmo e sotto-top in legno laccato opaco; disponibile anche con "lazy susan" in marmo incassato a filo del top.

Main structure in concrete and polished aluminium cast with surface treated and pigmented by hand. The armed concrete part is made even more material due to the exclusive erosion treatment and the matt black colour. Top in extra clear glass with 20 mm thickness, grounded and sanded by hand with airbrush technique, treated with anti-stain protective agents. Aluminium elements can be lacquered in any colour included in the metal finish selection. Weight 200 kg. Available in marble top version with lacquered wood under-top; available with turning "lazy susan" in marble built in the top.

● click here



VERSIONE CON TOP IN VETRO - GLASS TOP VERSION

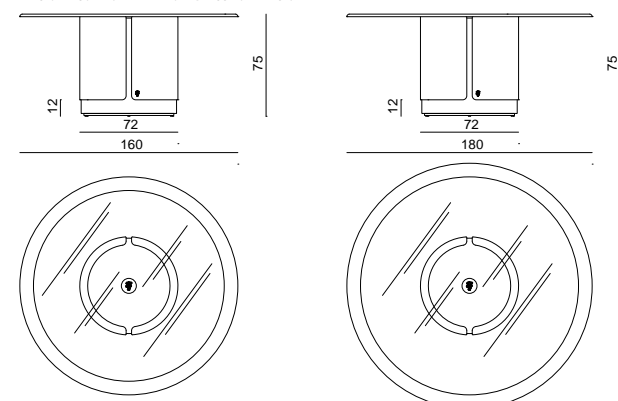

VERSIONE CON TOP IN MARMO - MARBLE TOP VERSION

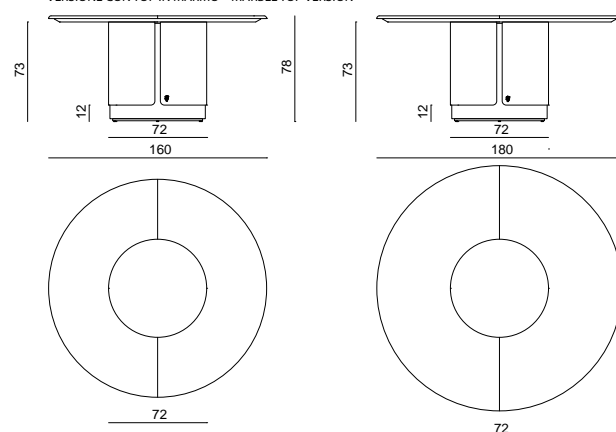

ARKADY

TAVOLO DA PRANZO - DINING TABLE

Alessandro La Spada

Struttura portante in fusione di alluminio e acciaio. Le quattro gambe, con finitura "martellata", sono lucidate a mano e collegate a un telaio portante a sostegno di un sotto-top in marmo Crema Marfil lavorato e decorato a mano con trama minerale in bassorilievo, disponibile nelle varianti cromatiche "Laguna" e "Tenerife". Top in vetro temperato extra-chiaro con bordo bisellato. Le parti metalliche sono disponibili nella selezione finiture metalliche.

Main structure in aluminium cast and steel. Four legs with hammered finish are polished by hand and connected to the main frame sustaining the lower top in marble Crema Marfil marble is treated and decorated by hand, creating a bas-relief mineral texture on its surface, available in two colour variations ("Laguna" or "Tenerife"). Top in extra clear tempered glass. Metal parts can be lacquered in any colour included in the metal finish selection.

● click here

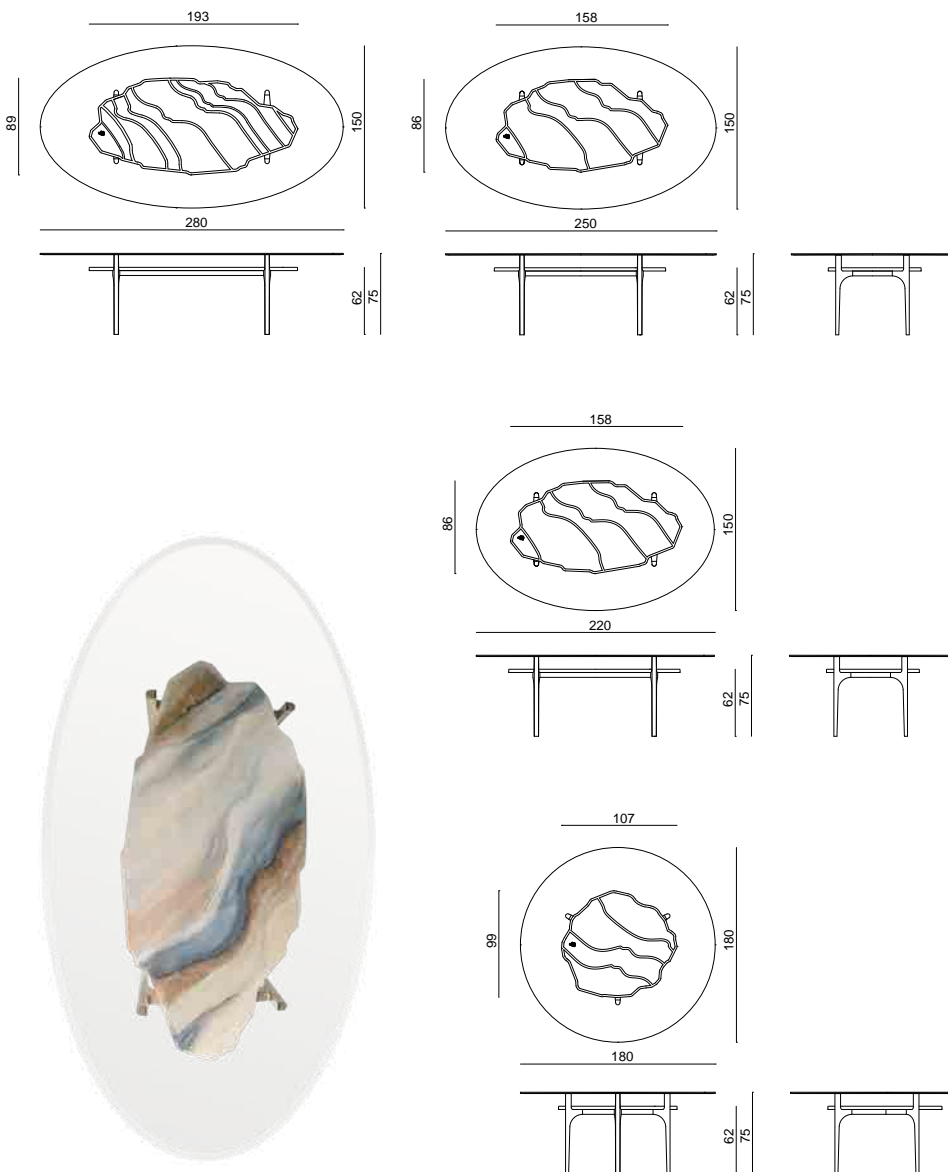



DYLAN 2022

TAVOLO DA PRANZO - DINING TABLE

Alessandro La Spada

Struttura in acciaio AISI 316, crociera e zavorra in ghisa verniciata a polvere. Gamba centrale in ottone rigato verniciato a polvere e anello decorativo in ottone cromato. Base in acciaio AISI 316 spazzolato. Top in vetro satinato sp. 8 mm, stratificato con stampa digitale sulla superficie, molato a filo lucido incollato su sotto-top in HPL. Cornice perimetrale in acciaio verniciato a polvere.

Le parti metalliche sono disponibili verniciate a polveri (per esterni).

Frame in AISI 316 steel, powder-coated cast iron cross and ballast. Striped powder-coated brass central leg and chrome-plated brass decorative ring. Brushed AISI 316 steel base. 8 mm thick satin-finish glass top, laminated with digital printing on the surface, ground to a polished edge glued onto HPL sub-top. Perimeter frame in powder-coated steel. Metal parts are available powder-coated (for outdoor use).

[click here](#)

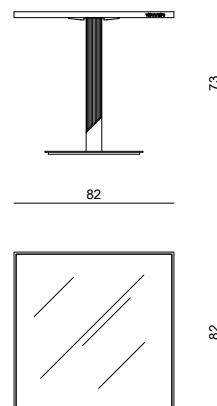

GALITSIN

TAVOLO DA PRANZO - DINING TABLE

Maria Serebryanaya

con intervento artistico di Roberta Verteramo
with Roberta Verteramo art intervention

Tavolo da pranzo rettangolare con top in marmo lavorato con inserto artistico composto da resine, gesso, rame e pigmenti disposti manualmente. Il bordo del top è lavorato con profilo smussato. Sotto-top in legno laccato lucido a sezione smussata. Basamento composto da due gambe in acciaio inox scatoletto a sezione romboidale. Le parti in metallo sono disponibili nella selezione finiture metalliche.

Rectangular dining table with top in marble decorated with artistic insert, made in resin, gypsum, copper and pigments applied by hand. Top edge with rounded profile. Rounded under-top in shiny lacquered wood. Base consisting of two legs in tubular steel with rhomboid section. Metal parts available in any colour included in the metal finish selection.

[click here](#)

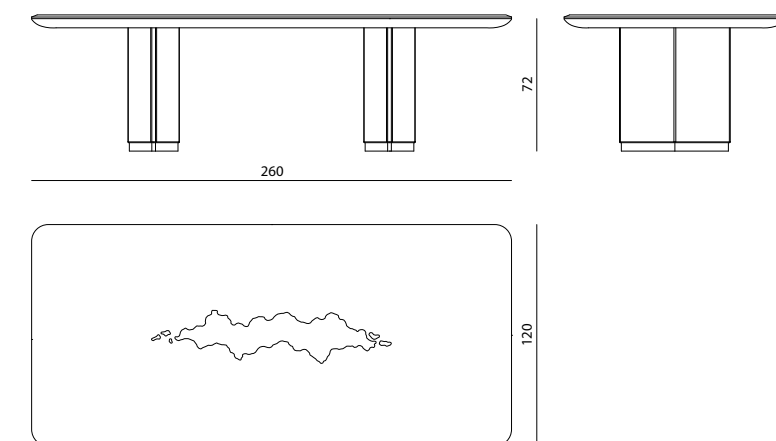



JASON

TAVOLO DA PRANZO - DINING TABLE

Roberto Lazzeroni

Tavolo da pranzo tondo con top in marmo composto da un macro-mosaico in tre tipologie di marmo intarsiate con profilo metallico da 5 mm in acciaio inox lavorato a filo del piano. Il bordo del top è lavorato con profilo smussato. Sottotop in legno laccato lucido a sezione smussata. Basamento composto da tre gambe concave in legno rivestito in cuoio nero con profili decorativi in acciaio inox satinato e traversi centrali. Disponibile con "Lazy Susan" incassato a filo del top oppure con "Lazy Susan" in appoggio asportabile. Le parti in metallo del basamento sono disponibili nella selezione finiture metalliche.

Disponibile versione JASON RADICA con gambe concave rivestite in radica con profili decorativi in acciaio inox satinato.

Round dining table with marble top composed of a macro-mosaic in three types of marble inlaid with a 5mm metal profile in stainless steel. The edge of the top is worked with a rounded edge. Undermount in glossy lacquered wood with rounded section. Base made of three concave wooden legs covered in black leather with decorative profiles in stainless steel. Available with turning "Lazy Susan" built in the top or removable leant on it. The metal parts of the base are available in the metal finishing selection.

Available JASON RADICA version with concave legs upholstered in burr walnut with decorative profiles in satin-finished stainless steel.

● click here

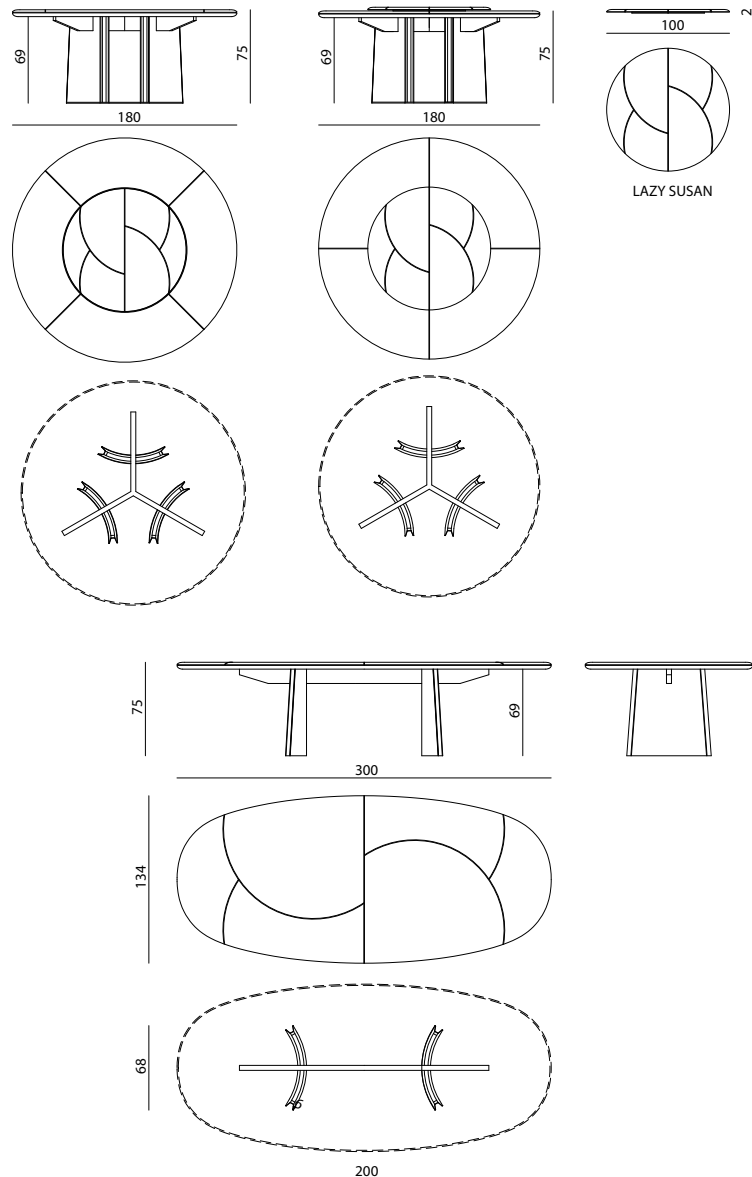

VERSIONE RADICA/ RADICA VERSION



KERWAN

TAVOLO DA PRANZO - DINING TABLE

Alessandro La Spada

Tavolo da pranzo, top in lastra di marmo con bordo bisellato in negativo e sotto-top in legno laccato. Basamento in acciaio inox lucido curvato su tre lati. Le superfici esterne concave del basamento sono realizzate in marmo curvato e lucidato. Le parti in acciaio sono disponibili nella selezione finiture metalliche. Il top e le superfici concave delle gambe sono disponibili anche nella versione in essenza nei materiali della selezione essenze.

Disponibile nella versione KERWAN RADICA con top e superfici concave delle gambe in radica lucida finitura 100 gloss, oppure nella combinazione con top in marmo e superfici concave in radica.

Dining table, top in marble with bevelled edge and under board in lacquered wood. Polished and curved stainless steel base with concave external surfaces made of curved and polished marble. Metal parts available in the metal finishing selection. Also available in the veneer version with top and concave wooden surfaces coated in the materials of the veneer selection finishings.

Available in the KERWAN RADICA version with top and concave surfaces of the legs in 100 gloss finish burr walnut, or in the combination with marble top and concave surfaces in burr walnut.

● click here



VERSIONE RADICA/ RADICA VERSION

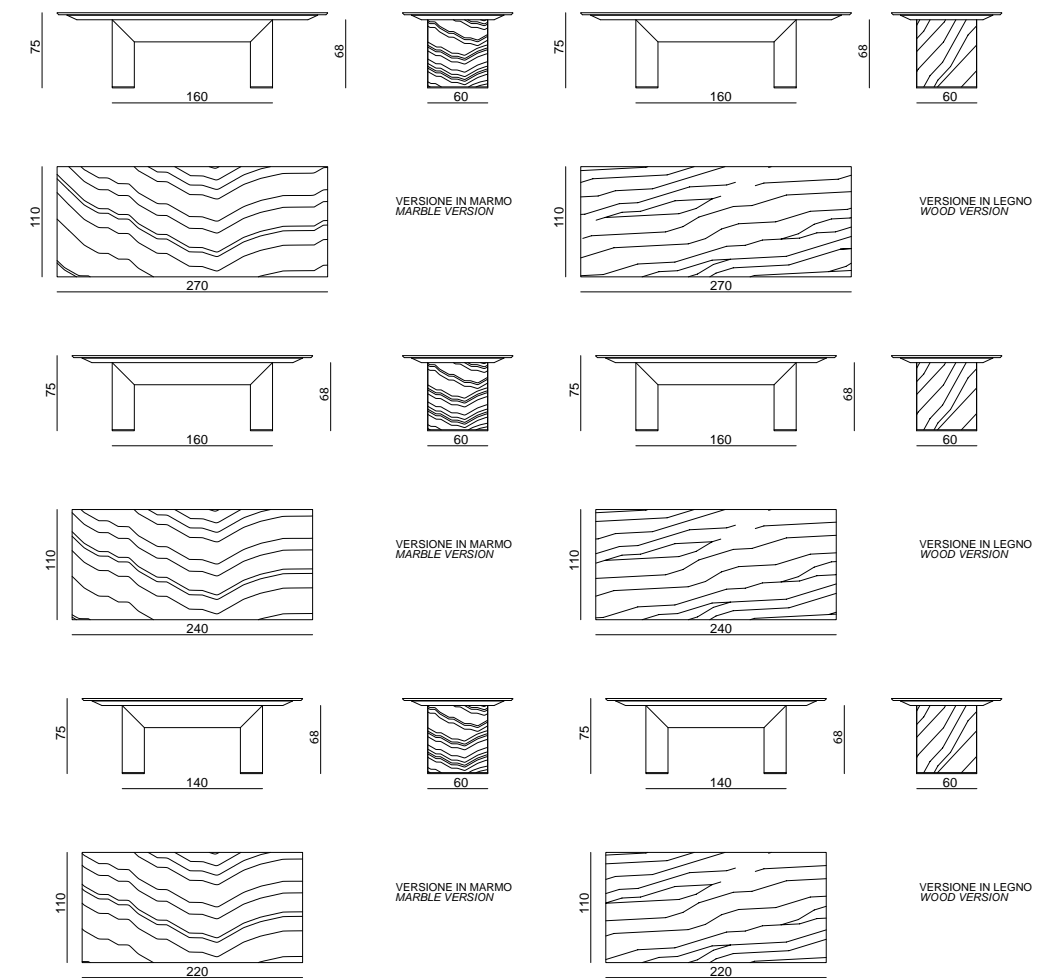

VERSIONE RADICA/ RADICA VERSION



KYLO

TAVOLO DA PRANZO - DINING TABLE

Alessandro La Spada

Tavolo da pranzo tondo in vetro fumè con bordo bisellato abbinabile a un piano rotante Lazy Susan in marmo in appoggio. Basamento formato da gambe in metallo curvato con rivestimento esterno trapuntato in pelle o tessuto e superficie interna in acciaio inox lucido. Le gambe sono collegate al top in vetro tramite supporti in alluminio e acciaio inox saldati a UV. Piastra di base in acciaio inox lucido. Le parti in metallo sono disponibili nella selezione finiture metalliche, il vetro del top è disponibile nelle varianti fumè, bronzo, extrachiaro. Disponibile anche in versione con top in marmo bisellato con inserti metallici a filo top in ottone o acciaio inox, fornito di sottotop in legno laccato nero opaco.

Round dining table in smoked glass with bevelled edge, with optional counter-top rotating serving tray 'Lazy Susan' in marble. Base with legs in shaped metal with external upholstery in quilted leather or fabric and internally covered in shiny stainless steel. Aluminium and steel supports for table legs bonded to the glass top using UV light. Basement in polished stainless steel. Metal parts can be finished with any lacquer of the metal lacquer finish selection, top available in smoked, bronze or extra-clear glass. Also available in marble bevelled top version, equipped with undertop in matt black lacquered wood.

vedi anche/see also KYLO FRAMED sedia-chair, KYLO PADDED sedia-chair. KYLO sgabello-stool

● [click here](#)

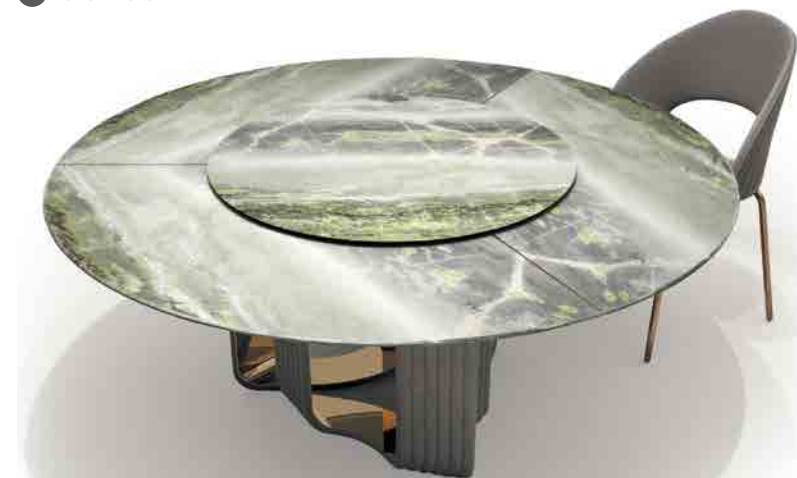

VERSIONE CON TOP IN VETRO - GLASS TOP VERSION

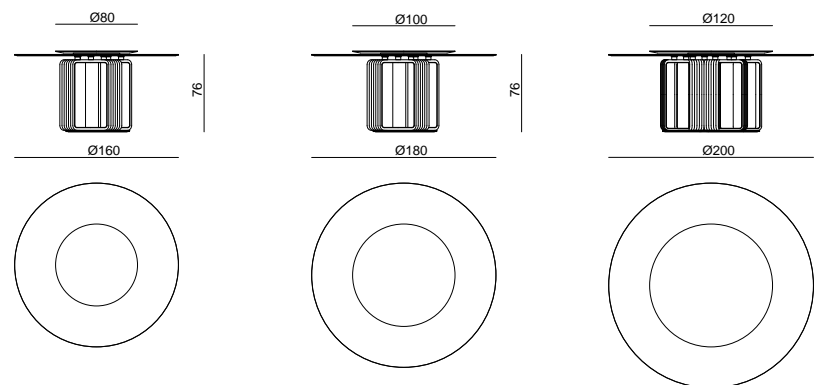

VERSIONE CON TOP IN MARMO - MARBLE TOP VERSION

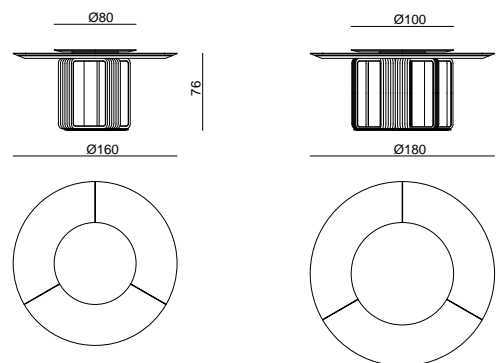

LEONARDO

TAVOLO DA PRANZO - DINING TABLE

Alessandro La Spada

Tavolo da pranzo in marmo. Top in marmo con sagoma ovale e bordo a mezzo toro, sotto-top in MDF verniciato lucido in colori RAL/NCS. Struttura del basamento in legno composta da uno zoccolo e profili verticali concavi rivestiti in acciaio inox lucido curvato in porzioni concave e convesse. Pannelli verticali scolpiti con lavorazione superficiale canneté in bassorilievo, disponibili con verniciatura lucida (colori RAL/NCS), nelle vernici metallescenti a campionario, oppure rivestiti in pelle Soft leather. I profili decorativi in acciaio inox curvato sono disponibili nella selezione finiture metalliche.

Dining table in marble. Marble top with oval shape and half bullnose border, undertop in glossy painted MDF in RAL/NCS colours. Wooden base structure consisting of a plinth and vertical concave profiles covered in polished stainless steel curved in concave and convex portions. Vertical panels decorated with 'canneté' stripes carved in low relief, available with shiny lacquer (RAL or NCS colours) finish or in metal colours as per finishes selection or upholstered in Soft leather. Interiors in matt RAL/NCS lacquer. Decorative profiles in curved stainless steel, available in the metal lacquer finish.

vedi anche/see also LEONARDO letto-bed, comodino-bedside table, LEONARDO cassettiera-chest of drawers, LEONARDO media-high unit, LEONARDO mobile basso-low unit, LEONARDO consolle portavabo-wellness unit, LEONARDO mobile bar-bar unit, LEONARDO libreria-bookshelf, LEONARDO armadio-wardrobe

● [click here](#)

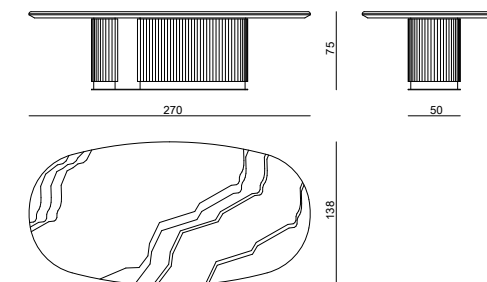



LYRIQUE

TAVOLO DA PRANZO - DINING TABLE

Alessandro La Spada

Struttura in legno con top in essenza o laccato lucido, basamento rivestito in pelle o tessuto con lavorazione cannettata, profili decorativi e base in acciaio inox satinato con logo Visionnaire inciso. Sottotop in alluminio verniciato. Top accessorato da tre fregi metallici sul bordo. Disponibile in opzione piano aggiuntivo con meccanismo circolare a cuscinetto rotante "Lazy Susan" in appoggio sul top del tavolo. Le parti in legno sono disponibili nelle finiture selezione essenze; gli elementi metallici sono disponibili nella selezione finiture metalliche satiniate.

Wooden structure with top in wood with veneered or glossy lacquered finish; base upholstered in leather or fabric with cannetté quilted motif; decorative profiles and base in satin stainless steel with engraved Visionnaire logo. Under-top in lacquered aluminium. Top comes with three decorative plates on the edge. Optional rotating serving tray "Lazy Susan" to be placed on top of the table. Wooden parts can be finished in any of the wood veneers included in the veneer finish selection. Metal parts can be finished in any of the lacquers included in the metal finish selection.

● click here

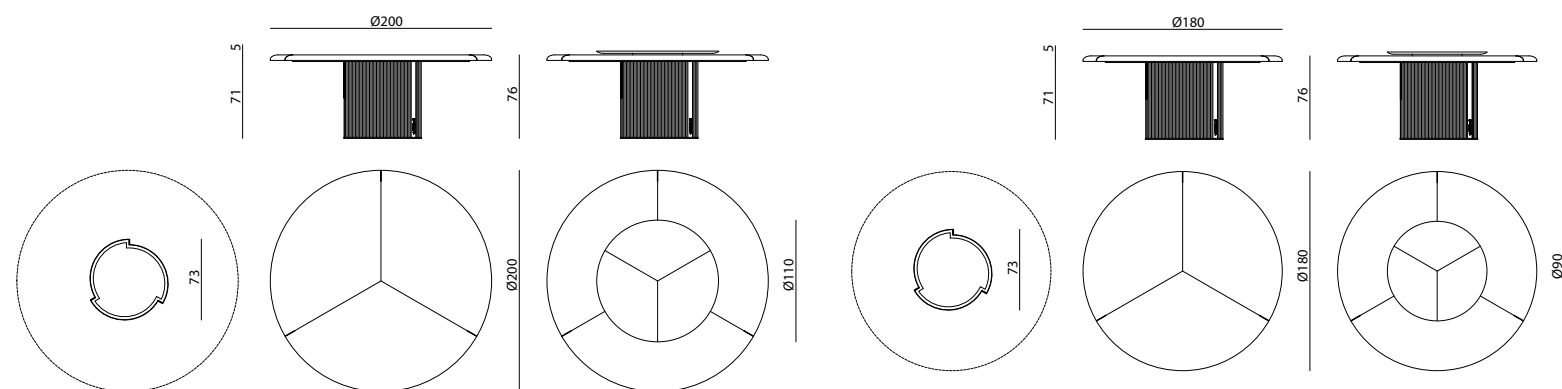

CON LAZY SUSAN IN APPOGGIO
WITH LAZY SUSAN PLACED ON TOP

CON LAZY SUSAN IN APPOGGIO
WITH LAZY SUSAN PLACED ON TOP



MORGAN

TAVOLO DA PRANZO - DINING TABLE

Fabio Bonfà

Tavolo da pranzo in marmo. Top in due marmi lucidati con bordo sagomato a mezzo toro e sotto-top in legno laccato lucido con bordo a mezzo toro (colori RAL), con profilo metallico di separazione con fibbie decorative in ottone cromato con logo inciso. Lazy susan in appoggio in due marmi lucidati, asportabile. I due marmi formano un disegno geometrico con grafica complementare. Basamento formato da tre gambe in tubolare metallico a sezione ovale parzialmente rivestite in pelle e unite al centro in un elemento a stella in metallo satinato con logo in ottone cromato. Le parti metalliche sono disponibili nella selezione finiture metalliche satiniate.

Dining table in marble. Top in two types of polished marble with shaped half-bullnose edge and undertop in polished lacquered wood with half-bullnose edge (RAL colours), divisory profil with decorative buckles in chromed brass engraved with logo. Lazy Susan on top in two types of marble, polished and removable. The 2 marbles design a geometric complementary pattern. Base made of 3 tubular metal legs with oval section, partly covered in leather, connected to a central block in satin metal with chromed brass logo, designing a star shape. Metal parts available with satin metal lacquered finish.

● click here

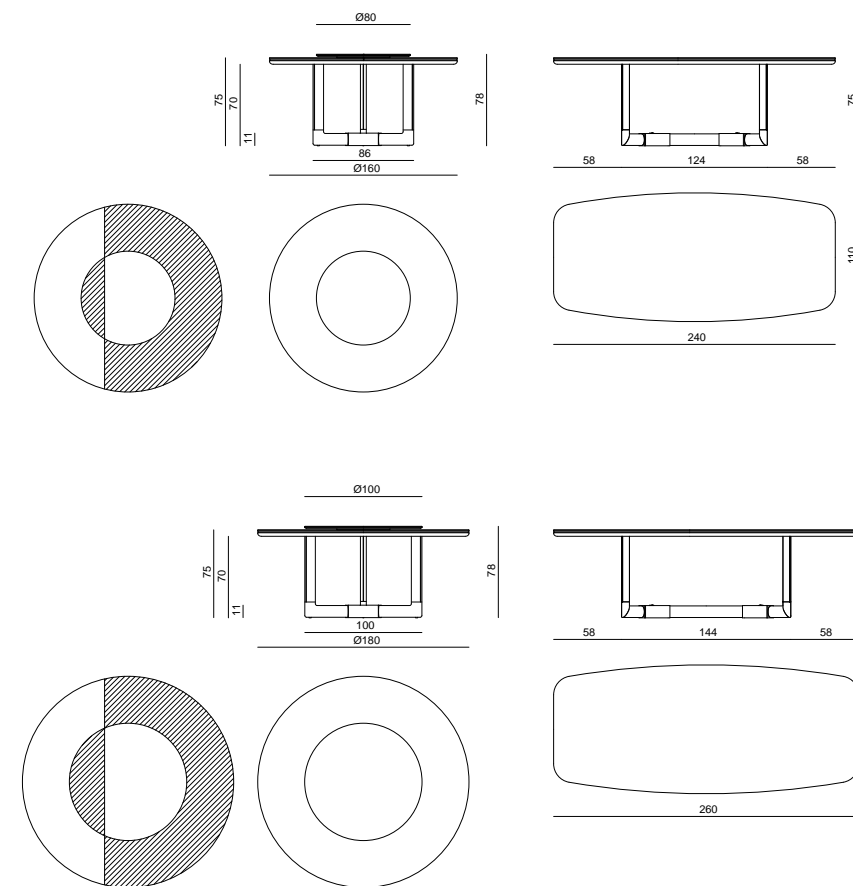



OPERA

TAVOLO DA PRANZO - DINING TABLE

Alessandro La Spada

Struttura in legno con top e base rivestita in essenza o laccata, basamento con lavorazione cannettata, profili decorativi e base in acciaio inox satinato con logo Visionnaire inciso. Sottotop in alluminio verniciato. Top accessorato da tre fregi metallici sul bordo e meccanismo circolare a cuscinetto rotante "Lazy Susan" a filo top, indipendente ed estraibile. Le parti in legno sono disponibili nelle finiture selezione essenze; gli elementi metallici sono disponibili nella selezione finiture metalliche satiniate.

Structure of top and base in veneer or lacquered, staggered base with cannettè decoration, decorative profiles and base in satinized stainless steel with engraved Visionnaire logo. Undertop in painted aluminium. Top decorated with 3 metal friezes on the edge and turning "Lazy Susan" built in the top, removable. Wooden parts available in the veneer selection finishings; metal parts available in the satinized metal finishing selection.

Winner of the 2018 AD's Great Design Awards

● click here

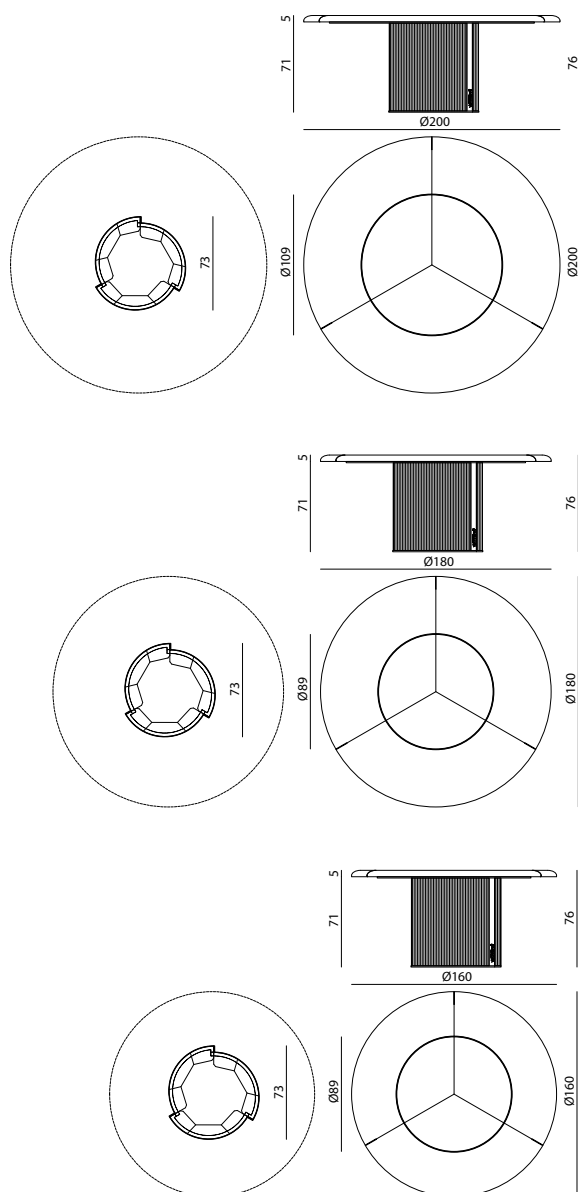

PALACE

TAVOLO DA PRANZO - DINING TABLE

Fabio Bonfà

Tavolo da pranzo in marmo. Top in marmo lucidato con bordo sagomato a mezzo toro e sotto-top in legno laccato lucido con bordo a mezzo toro (colori RAL), con profilo metallico di separazione con fibbie decorative in ottone cromato con logo inciso. Lazy susan in appoggio in marmo lucidato, asportabile. Basamento formato da due plinti sfaccettati in legno laccato lucido e superfici esterne rivestite in pelle o tessuto con lavorazione a trapunta cannettata. Le parti metalliche sono disponibili nella selezione finiture metalliche satiniate.

Dining table in marble. Top in polished marble with shaped half-bullnose edge and undertop in polish lacquered wood with half-bullnose edge, metal divisory profil with decorative buckles in chromed brass engraved with logo. Lazy susan on top made in polished marble. Base made of 2 multi-faceted pillars in polished lacquered wood and external surfaces covered in leather or fabric, decorated with cannettè quilted motif. Metal parts available with satin or polished metal lacquered finish.

● click here

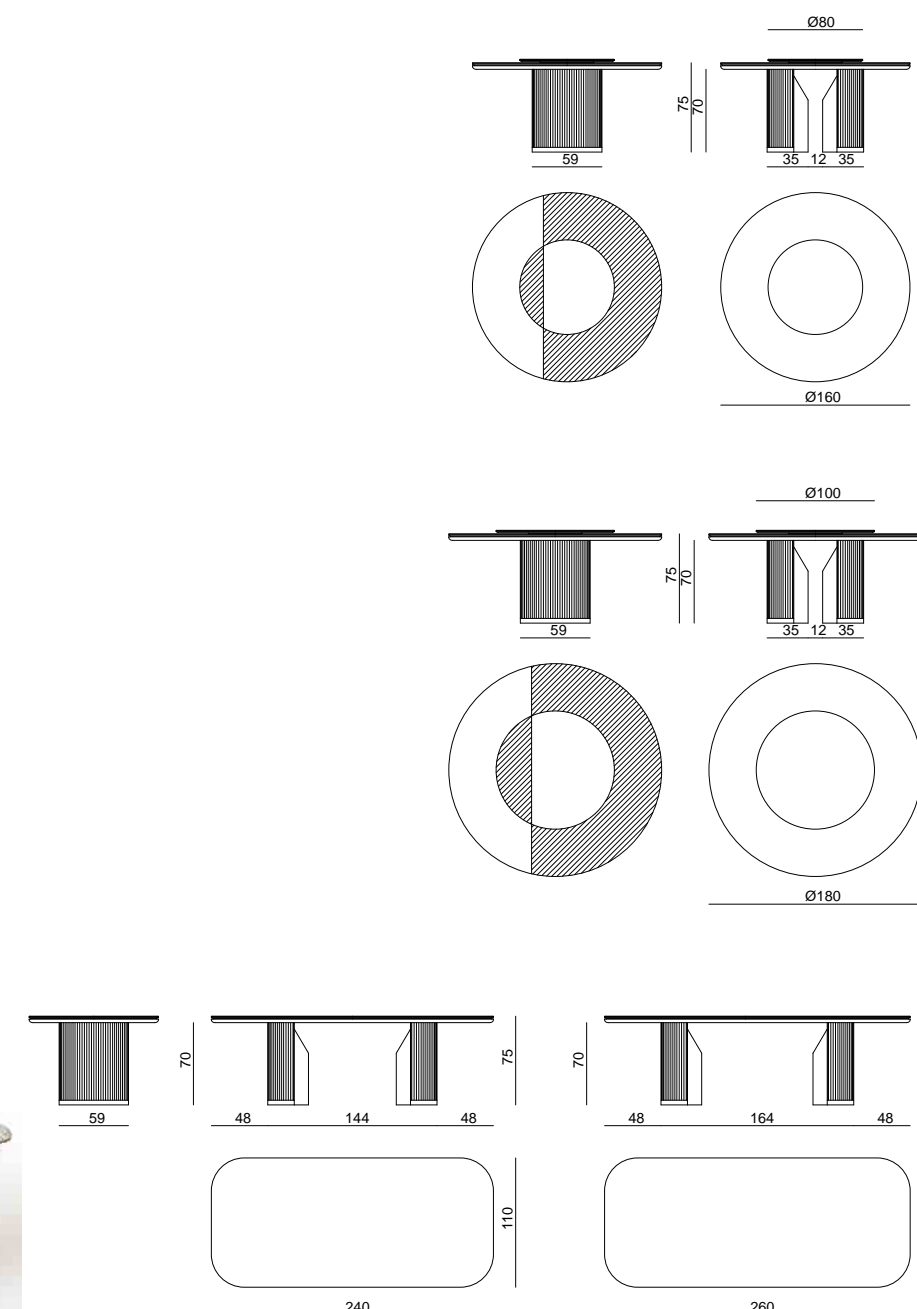



RAIDHO

TAVOLO DA PRANZO - DINING TABLE

Steve Leung

Top in marmo e ametista intarsiato con disegno composto da Mistery White, Nero Marquina, Ametista Viola e profilo di acciaio inox sp.3mm finitura cromo. Cornice del piano in acciaio inox con decoro geometrico ottenuto con tre diverse lavorazioni a mano di lucidatura e satinatura. Sottotop in legno tornito, laccato lucido 100 gloss (colori RAL). Basamento composto da una colonna conica su base sagomata in metallo cromato. Stelo portante e zavorra sotto la base in ferro verniciato. Sono disponibili combinazioni diverse. Cornice solo finitura cromo. Base disponibile in finitura oro, bronzo oppure nickel nero.

Lazy Susan in marmo con costa lavorata e sistema a cuscinetto rotante.

Top in combinazione di marmi disponibile in: Mistery White, Black Marquina, Purple Amethyst oppure Mystic Brown, Arabescato Orobico Grigio, Rosso Levanto Turco.

Marble and amethyst inlaid top with design in Mistery White, Black Marquina, Purple Amethyst and 3mm stainless steel profile chrome finishing. Top frame in stainless steel with geometric decoration obtained through different handmade procedures of polishing and brushing. Under top of turned lacquered polished 100 gloss wood (RAL colours). Base composed by a conical column on a shaped chromed metal base. Central support and ballast under base in painted iron. Several combinations are possible. Top profile in chromed finishing. Base metal parts are available in golden, bronze and black nickel finishing.

Lazy Susan in marble with safety edge and rotating weight holder system.

Top in composition of marbles available in: Mistery White, Black Marquina and Purple Amethyst or Mystic Brown, Arabescato Orobico Grigio and Rosso Levanto Turco.

[click here](#)

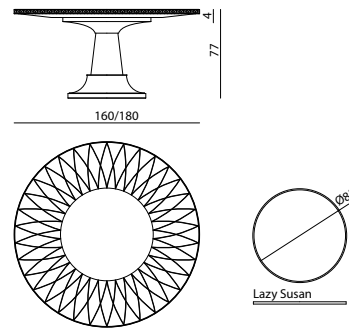
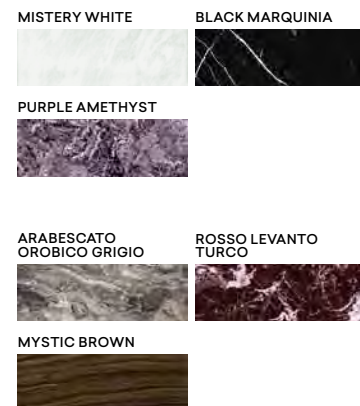
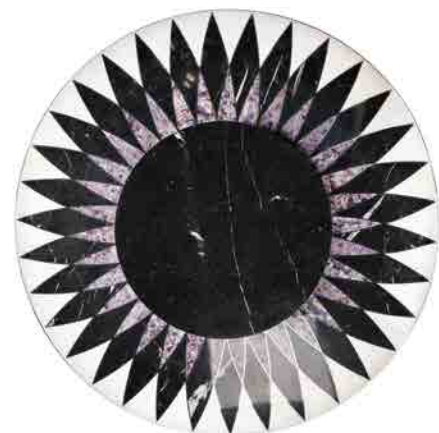
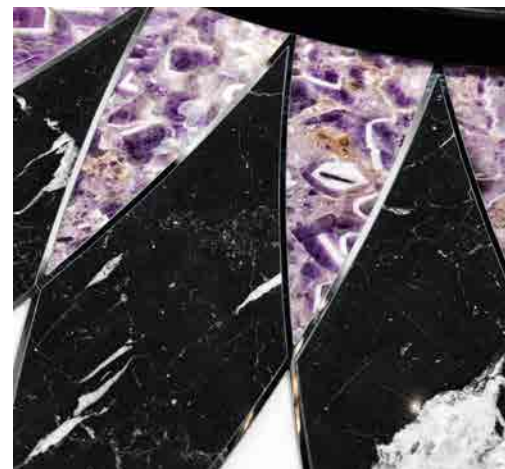

REVENGE

TAVOLO DA PRANZO - DINING TABLE

Alessandro La Spada

Tavolo da pranzo con top in mosaico di marmo con disegno geometrico. Profilo perimetrale del top in acciaio inox monolitico lucidato sp. 5 mm con struttura portante in ferro verniciato. La base è formata da due strutture scatolate in acciaio satinato con bordi lucidi. Gli acciai sono disponibili nella selezione finiture metalliche; gli acciai lucidi del bordo del top e delle gambe possono avere colorazione a contrasto col corpo satinato delle gambe. Disponibile anche in diverse combinazioni omogenee di marmi oppure onici oppure graniti.

Top in combinazione di marmi disponibile in: Gold composition: Giallo Moicano, Emerald Quarzite, Sahara Noir, Cipollino Toscano, Absolute Black; Blue composition: Black Marquina, Calcite Azul, Silverwave, Arabescato Vagli, Bardiglio Grigio; Green composition: Verde Remeggiato, Emerald Quarzite, Sahara Noir, Cipollino Toscano, Absolute Black.

Dining table with top in marble mosaic, creating a geometrical pattern. Monolithic perimetral profile of the top in polished stainless steel, 5 mm in width, with main structure in lacquered iron. The base consists of 2 box-shaped structures in satinized steel with polished edges. Steel parts are available in any colour included in the metal finish selection. The polished steel of the top profile and legs is available also in a stain contrasting with the colour of the main satinized structure of the legs. Available also with different homogeneous combinations of marbles or onyxes or granites.

Top in composition of marbles available in: Gold composition: Giallo Moicano, Emerald Quarzite, Sahara Noir, Cipollino Toscano, Absolute Black; Blue composition: Black Marquina, Calcite Azul, Silverwave, Arabescato Vagli, Bardiglio Grigio; Green composition: Verde Remeggiato, Emerald Quarzite, Sahara Noir, Cipollino Toscano, Absolute Black.

[click here](#)

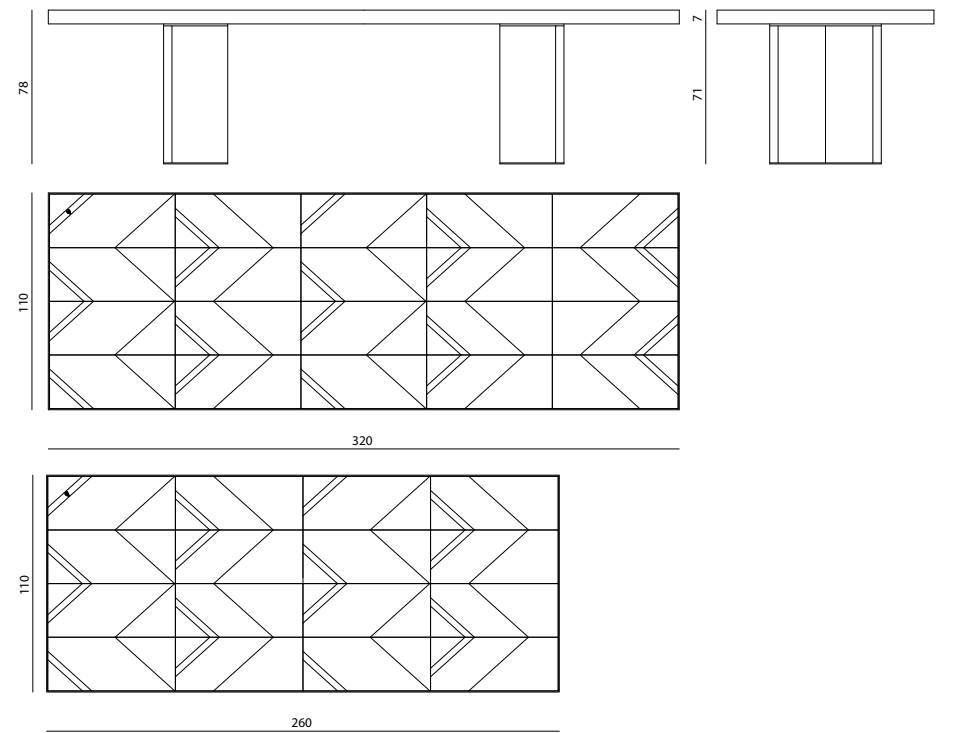



ROHAN

TAVOLO DA PRANZO - DINING TABLE

Steve Leung

Tavolo da pranzo tondo in marmo e legno. Top in marmo con disegno ad archi e inserti decorativi in ottone levigato a filo marmo, e un inserto superficiale in ottone anticato. Perimetro del top lavorato con bordo svasato. Basamento in legno scolpito, rivestito in essenza disponibile a 5 gloss o 100 gloss, sotto-top in legno laccato nero lucido. L'essenza del basamento è disponibile in frassino tinto opaco o nella selezione essenze con finitura lucida o opaca.

Disponibile con "Lazy Susan" da appoggio in marmo, con bordo svasato e dispositivo di rotazione a basso attrito con piedini in gomma.

Round dining table in marble and wood. Marble top with arched design in polished brass flush with marble and decorative inserts in antique brass. Top perimeter with flared edge. Carved wooden base, covered in veneered wood available in 5 gloss or 100 gloss, undertop in glossy black lacquered wood. The veneer of the base is available in matt stained ash or in the veneer selection with polished or matt finish.

Available with "Lazy Susan" marble countertop, with flared edge and low-friction turning device with rubber feet.

[click here](#)

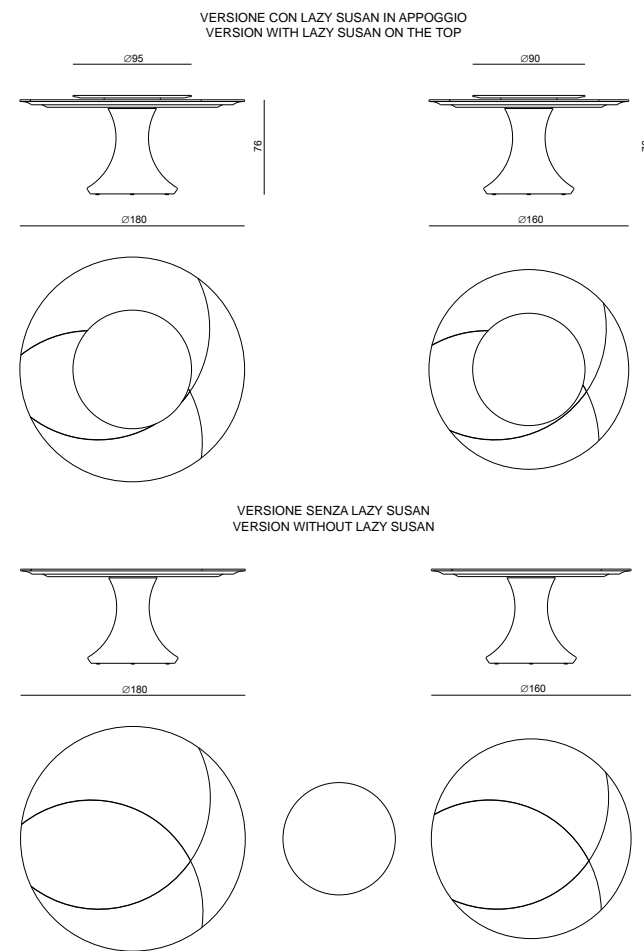
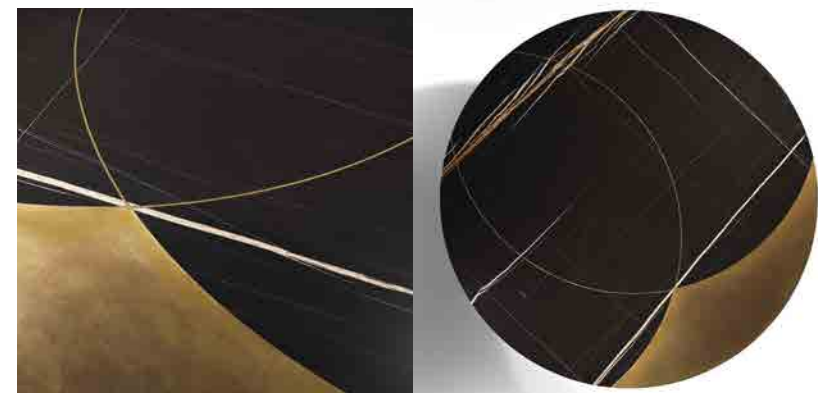

SOLSTICE

TAVOLO DA PRANZO - DINING TABLE

Alessandro La Spada

Struttura a gabbia su base ellittica o circolare in acciaio inox taglio laser. Base e top in acciaio inox piatto, montanti sagomati a scafo di nave in acciaio inox piatto. Top in vetro extrachiaro sp. 15 mm temperato. Le parti metalliche sono disponibili nella selezione finiture metalliche.

Cage structure on elliptic or circular base in laser cut stainless steel. Base and top in flat stainless steel, bars shaped as boat hull in flat stainless steel. Top in extra-clear tempered glass th. 15 mm. Metal parts can be lacquered in any colour of the metal finish selection.

vedi anche/see also SOLSTICE tavolo basso-low table

[click here](#)

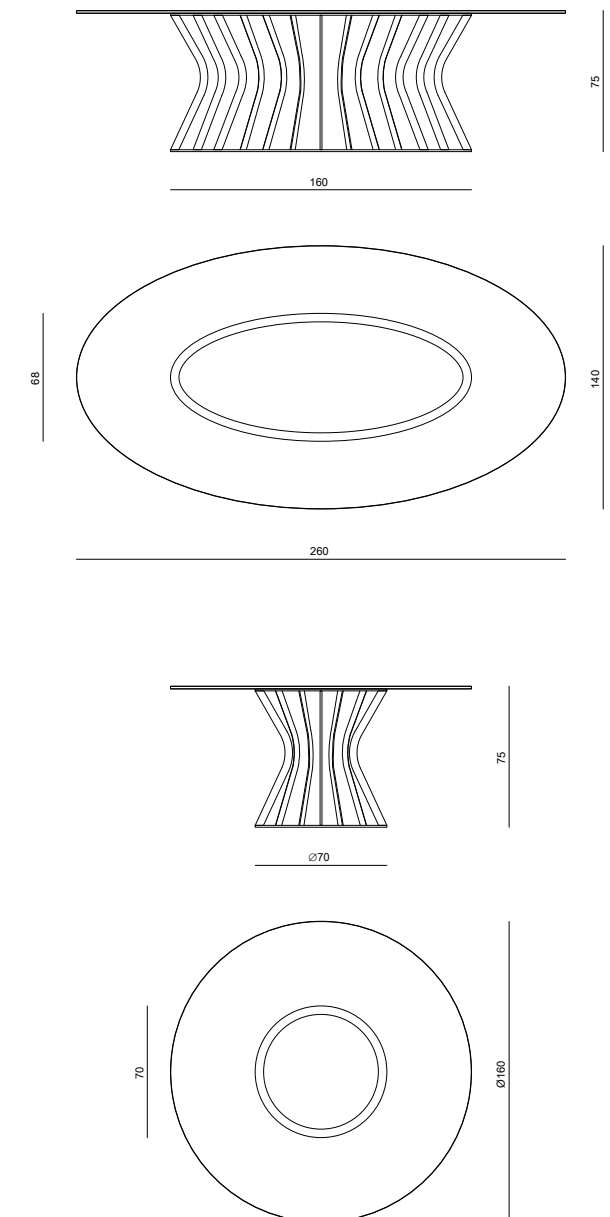



STONE

TAVOLO DA PRANZO - DINING TABLE

Fabio Bonfà

Tavolo da pranzo rettangolare in marmo scatola. Struttura portante in metallo a traliccio, con 4 gambe. Top e gambe in marmo scatola con fasce laterali da 6 cm, il top e le fasce laterali sono lavorati in continuità di vena. Rivestimento interno gambe e sotto-top in lamina di acciaio inox lucido. Le parti in metallo sono disponibili nella selezione finiture metalliche.

Rectangular dining table with boxed marble. Support structure in lattice metal 4 legs. Top and legs in boxed marble with 6 cm side strips, the top and side strips are worked in vein continuity. Internal leg and under-top cladding in polished stainless steel foil. Metal parts are available in the metal finishing selection.

vedi anche/see also STONE sedia-chair

● [click here](#)

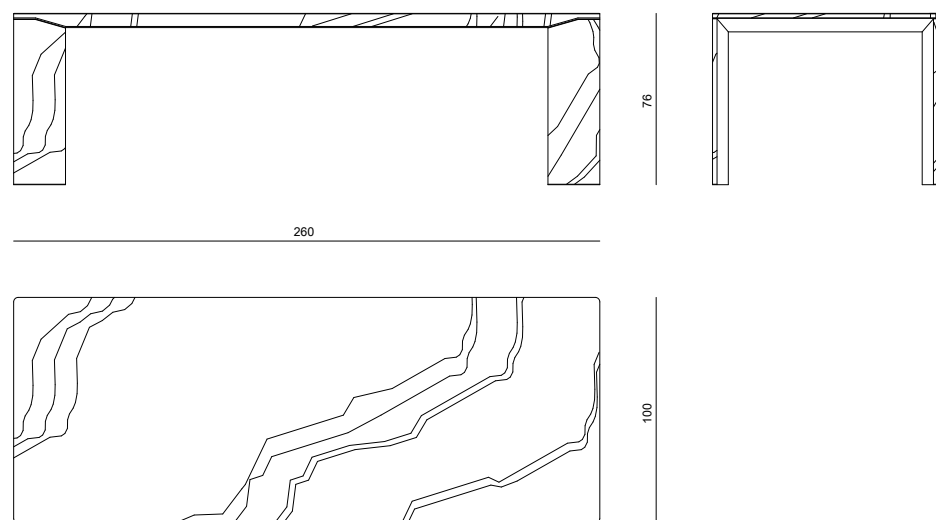

TEMPTATION

TAVOLO DA PRANZO - DINING TABLE

Alessandro La Spada

Tavolo da pranzo con top in legno rivestito in essenza con lavorazione a mosaico con disegno geometrico e logo Visionnaire in acciaio intarsiato. Profilo perimetrale del top in acciaio inox. Due basi in acciaio scatola con finitura satinata e bordi lucidi. Le parti in acciaio sono disponibili nella selezione finiture metalliche. Il top è disponibile nelle finiture selezione essenze.

Dining table, top in wood coated in veneered wood assembled with a mosaic motif creating a geometrical pattern, and Visionnaire logo in carved steel. Top frame profile in stainless steel. Two bases in satinized stainless steel with polished edges. Metal parts available in the metal finishing selection. Top available in veneer selection finishings.

● [click here](#)

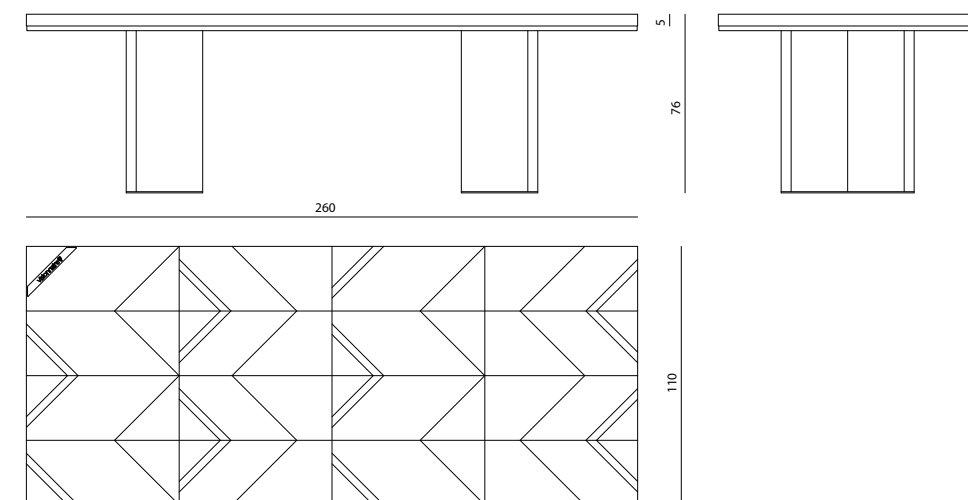



THULE

TAVOLO DA PRANZO - DINING TABLE

Steve Leung

Top in marmo intarsiato con acciaio inox lucidato a filo, incassato in cornice di acciaio inox lucidato. Base e gambe in fusione di alluminio lucidato a specchio e puntali satinati, disponibili nella selezione finiture metalliche.

Top in inlaid marble with polished stainless steel edge. Frame in polished stainless steel. Base and legs in polished cast aluminium and brushed nails, available in any colour included in the metal finish selection.

● [click here](#)

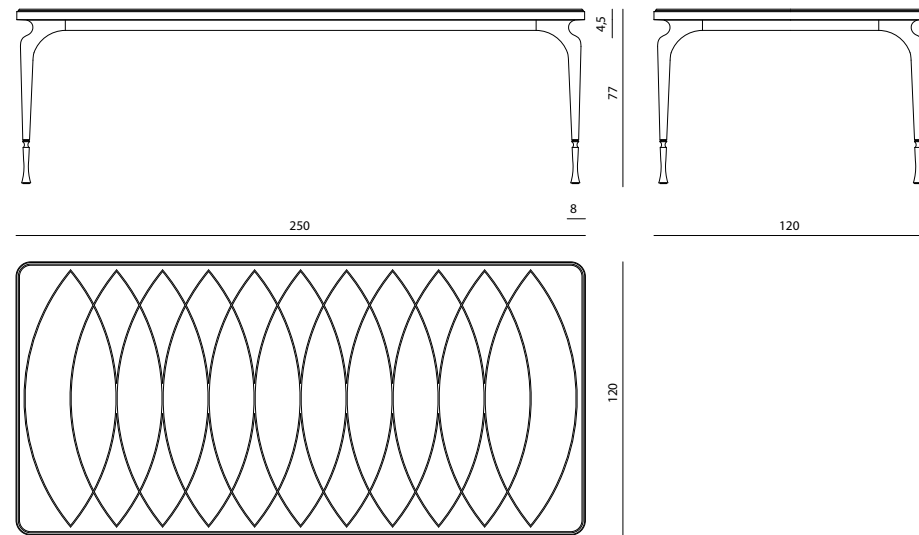

VALIANT

TAVOLO DA PRANZO - DINING TABLE

Alessandro La Spada

Tavolo in legno e marmo, top ad alto spessore in legno multistrati e impiallacciato con angoli irregolari in marmo da 20 mm scatola anche sullo spessore, di 85 mm. Due gambe in legno multistrati e marmo scatola con base rivestita in acciaio a profilo irregolare. Traverso sotto-top di irrigidimento strutturale. Le parti in legno sono disponibili nella selezione essenze con finitura opaca. Le parti in metallo sono disponibili nella selezione finiture metalliche.

Table in wood and marble, thick multilayer wood and veneer top with irregular 20 mm boxed marble corners also 85 mm thick. Two legs in multilayer wood and boxed marble with irregular profile steel covered base. Crossbar under top for structural stiffening. The wooden parts are available in the veneer selection with matt finish. Metal parts are available in the metal finish selection.

● [click here](#)

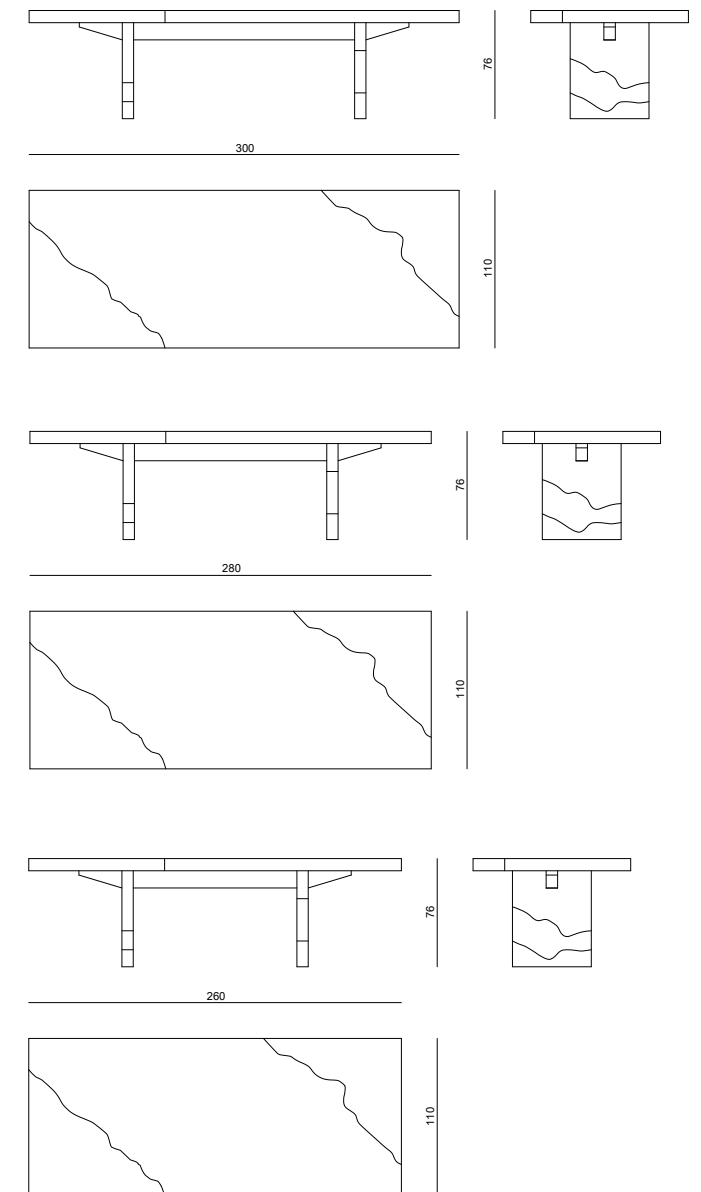



CHATAM

TAVOLO DA PRANZO - DINING TABLE

Alessandro La Spada

Struttura in acciaio inox lucido, gambe in fusione di alluminio con texture "croco" che in bassorilievo è smaltata con logo Visionnaire applicato, e in altorilievo è in ottone lucidato a specchio. Top in marmo. Le parti metalliche sono disponibili nella selezione finiture metalliche.

Structure in polished stainless steel. Legs in aluminium fusion polished and mirrored with enamelled "crocodile" design, with Visionnaire logo in high relief. Top in marble. Metal parts can be lacquered in any colour included in the metal finish selection.

vedi anche/see also CHATAM divano, poltrona-sofa, armchair, CHATAM tavolino-low table

[click here](#)

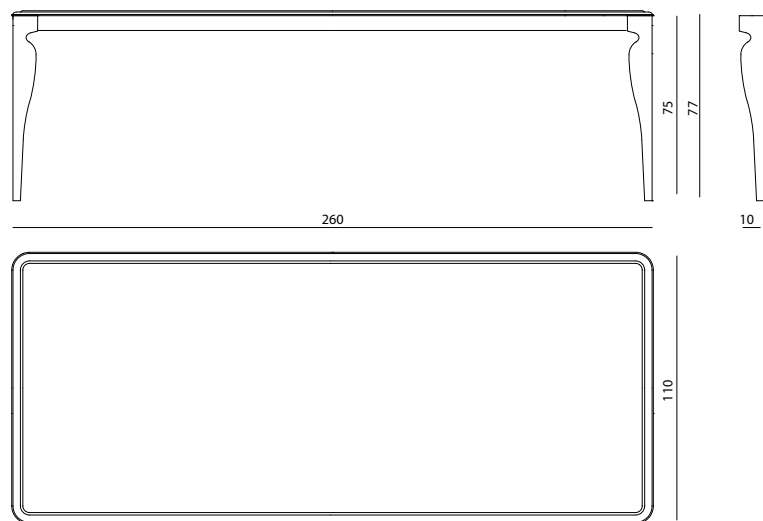

VERSAILLES

TAVOLO DA PRANZO - DINING TABLE

Alessandro La Spada

Struttura portante in MDF sagomato e curvato, laccato lucido al poliestere spazzolato. Top in marmo con bordo bisellato. Gambe composte da elemento principale tronco-cono in cristallo soffiato e molato con lavorazione a bugne, finitura acidata. Elementi torniti e sfera in alluminio e ottone finitura oro. Disponibile anche nella versione con pianetto centrale girevole "Lazy Susan" con top in marmo.

Main structure in shaped and curved MDF, shiny brushed polyester lacquered. Top in marble. Legs made of cone-truncated element in blown and grinded crystal, with diamond pattern and with frosted finishing. Turnings and sphere in aluminium and gold brass. Available also in the version with "Lazy Susan" swivel plate with top in marble.

vedi anche/see also VERSAILLES consolle-console, VERSAILLES mobile bar-bar cabinet, VERSAILLES cassetiera-chest of drawers

[click here](#)

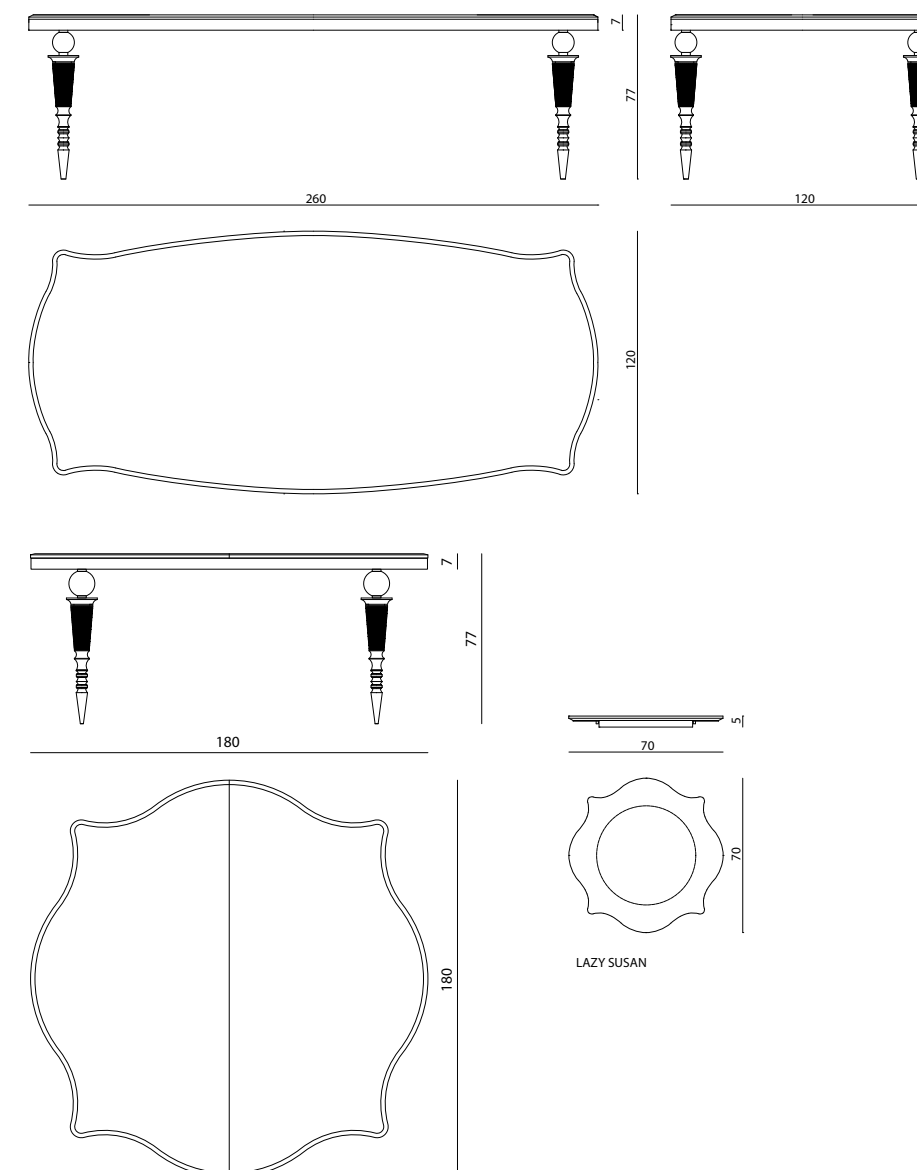



WINDSOR

TAVOLO DA PRANZO - DINING TABLE

Alessandro La Spada

Struttura in legno laccato 100 gloss con montanti e profili a rilievo e fregi decorativi in ottone, decorazioni delle gambe in alluminio e acciaio laserato, loghi Visionnaire sotto trasparenti. Top in marmo. Le parti metalliche sono disponibili nella selezione finiture metalliche.

Top in marble. Structure in 100 gloss lacquered wood with pillars and outlines in relief and brass decorative elements, aluminium and laser cut steel decorations on the legs. Visionnaire coat of arms under transparent lacquer. Metal parts can be lacquered in any colour included in the metal finish selection.

vedi anche/see also WINDSOR mobile trucco-make-up unit, WINDSOR scrittoio con cassetti-desk with drawers, WINDSOR vetrinetta-showcase, WINDSOR parete modulare-modular elements, WINDSOR armadio-wardrobe, WINDSOR specchio-mirror, WINDSOR vaso-vase, WINDSOR wellness room

[● click here](#)

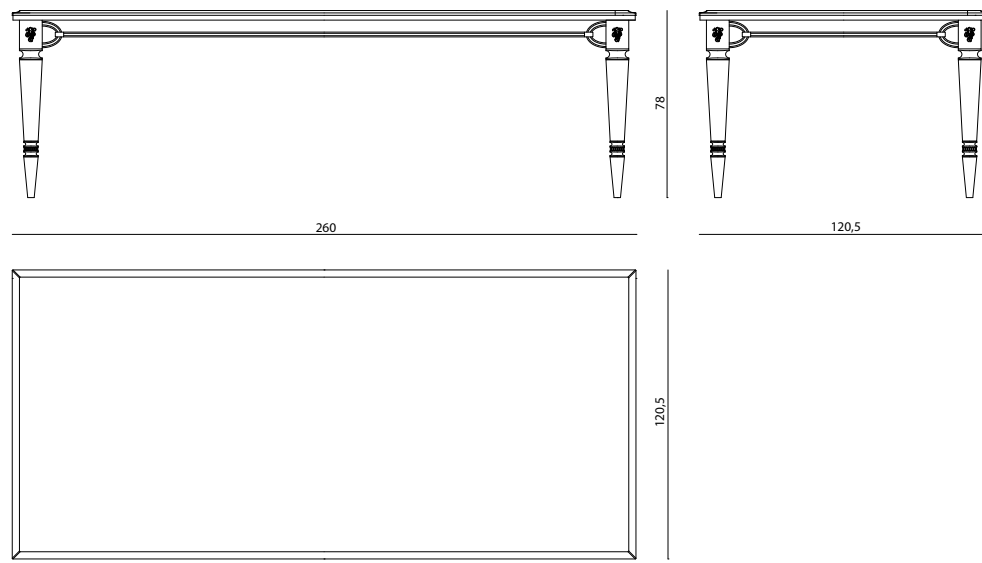

- click on the icons -



ACER p.220



ADMETO p.220



ATREYU p.221



AURYN p.221



BANNER p.222



BARRETT p.222



BUILDING p.223



BREEZE INDOOR p.224



BUTTON p.225



CHARLES p.225



CYBORG p.226



DOUGLAS p.227



EGMONT p.227



EGOISTE p.228



FOSTER p.228



FITZGERALD p.229



FRANKY p.229



FRANKY p.230



GEORG p.230



GRANGER p.231



HANSEL p.231



HAVOK p.232



JAMBOREE p.232



HORIZON FLAT p.233

- click on the icons -



HORIZON TRAY p.233



KENAZ p.234



KINGS CROSS p.234



KINGS CROSS p.235



KINGS CROSS p.235



KORVAC p.236



LEGO p.236



MARTY p.237



MILLER p.237



MINSTREL p.238



MONDRIAN p.238



ORBITAL p.239



PELLEAS p.239



RUBEN p.240



RUIS p.240



RUPERT p.241



RYLAN p.241



SARIN p.242



SOWILO p.242



SOWILO HIGH p.243



SOLSTICE p.243



STINGER p.244



TANGUY p.244



TRAPEZE p.245

- click on the icons -



TRAPEZE p.245



VINCENT p.246



WOODY p.246

ICONICI - *ICONIC*



CHANTILLY p.248



CHATAM p.248



DONALD p.249



MAXIM'S p.249



WEXFORD p.250



ACER

TAVOLO BASSO - LOW TABLE

Alessandro La Spada - Samuele Mazza

Struttura in compensato multistrati spessore 30 mm. Rivestimento esterno in vetro retrolaccato nei colori di serie o "Golden Antique" (vetro specchio colorato, ottenuto per mezzo di argentature speciali, ad esplosione di colore, che determinano un effetto tridimensionale sulle superfici). Vetri con spessore 6 mm, bisellati su tutti i lati. Disponibile anche nella versione ACER/C: quadrato 150x150 cm, con nr. 4 cassetti oppure rettangolare 75x150 cm, con nr. 2 cassetti. Dimensione cassetto: 70x70x13 cm.

Structure in plywood of thickness 30 mm. External cover in retro-lacquered glass in standard colours or "Golden Antique" (coloured mirror glass, obtained by means of special silver-plating, colour explosion, which determine a three dimensional effect on the surface). Glass of thickness 6 mm, bevelled on all sides. Available also in the version ACER/C: square 150x150 cm, with 4 drawers or rectangular 75x150 cm, with 2 drawers. Drawer dimension: 70x70x13 cm.

vedi anche/see also ACER consolle-console, ACER specchiera-mirror

[click here](#)

ADMETO

TAVOLO BASSO - LOW TABLE

Marco Piva

Tavolo basso composto da un top in vetro fumé sp. 8 mm, incastonato in tre basamenti monolitici rivestiti esternamente in marmo con accoppiamento a 45° in continuità di vena. Le pareti interne sono rivestite in acciaio inox con lavorazione in bassorilievo a doppio livello in finitura alternata lucida e satinata. Le parti in metallo sono disponibili nella selezione finiture metalliche.

Low table composed by top in smoked glass with 8 mm thickness, encased in 3 externally bases covered in marble by open-book vein match. Internal sides covered in double layer stainless steel with engraved stripes in bas-relief, alternating polish and satin finish. Metal parts are available in the metal finish selection.

Winner of the 2021 Wallpaper* Design Awards, "Best curves" category

[click here](#)

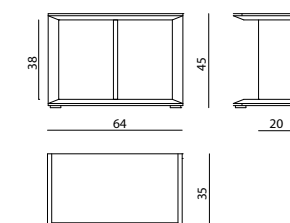
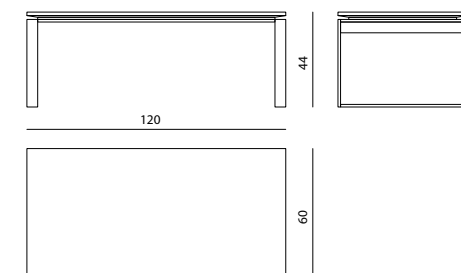
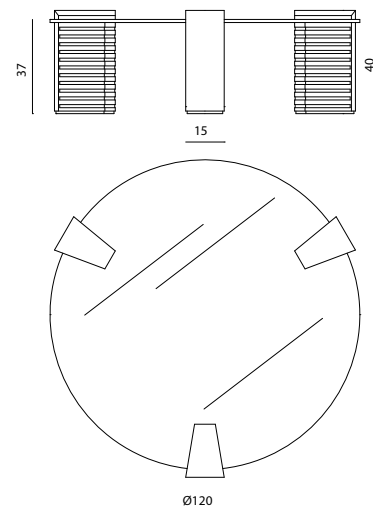
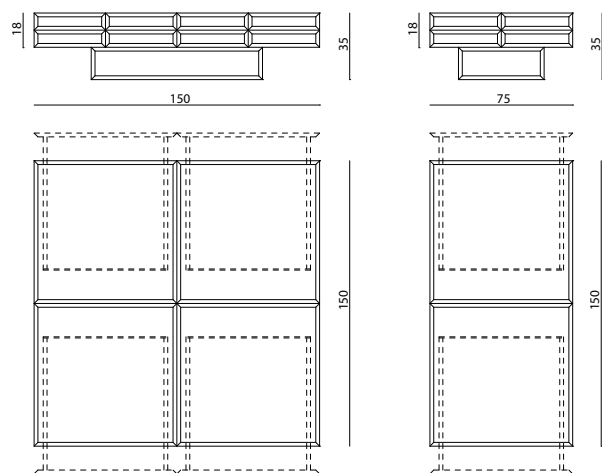



BANNER

TAVOLO BASSO - LOW TABLE

Fabio Bonfà

Tavolo basso a 4 cassetti in legno scolpito in bassorilievo con disegno a righe verticali, top in marmo con profilo lavorato in negativo. Telaio e profili decorativi in acciaio inox satinato. I cassetti sono rivestiti internamente in microfibra. Le parti in legno sono disponibili nelle finiture opache B.180, B.181, B.182, C.001. Le parti metalliche sono disponibili nella selezione finiture metalliche satinato.

Coffee table with 4 drawers in carved wood in low relief with vertical stripes design, marble top with negative machined profile. Frame and decorative profiles in brushed stainless steel. Drawers internally lined with microfibre. The wooden parts are available in matt finishes B.180, B.181, B.182, C.001. Metal parts available in the satinized metal finishing selection.

vedi anche/see also BANNER consolle-console

● click here

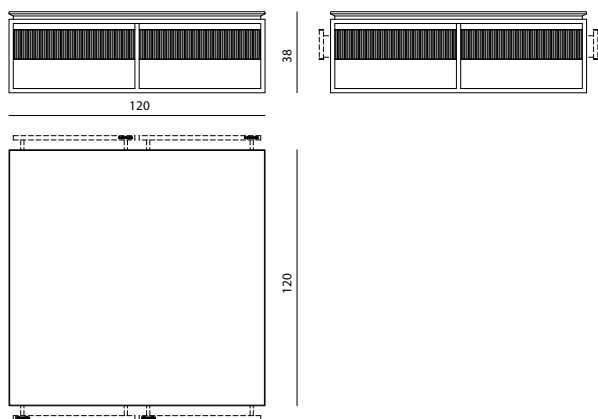

BARRETT

TAVOLINO - SMALL TABLE

Alessandro La Spada

Tavolino in acciaio e vetro, telaio in acciaio inox satinato con quattro gambe inclinate con finitura a satinatura profonda con logo inciso. Top e fianchi in lastra di vetro fumé da 10 mm saldati a UV sagomati con spigoli sfaccettati. Il telaio è disponibile nella selezione finiture metalliche.

Low table in steel and mirror, frame in satinized stainless steel with 4 slanted legs with logo engraved. UV-welded shaped top and sides in smoked 10 mm glass with faceted corners. The frame can be lacquered in any colour included in the metal finish selection.

vedi anche/see also BARRETT consolle-console

● click here

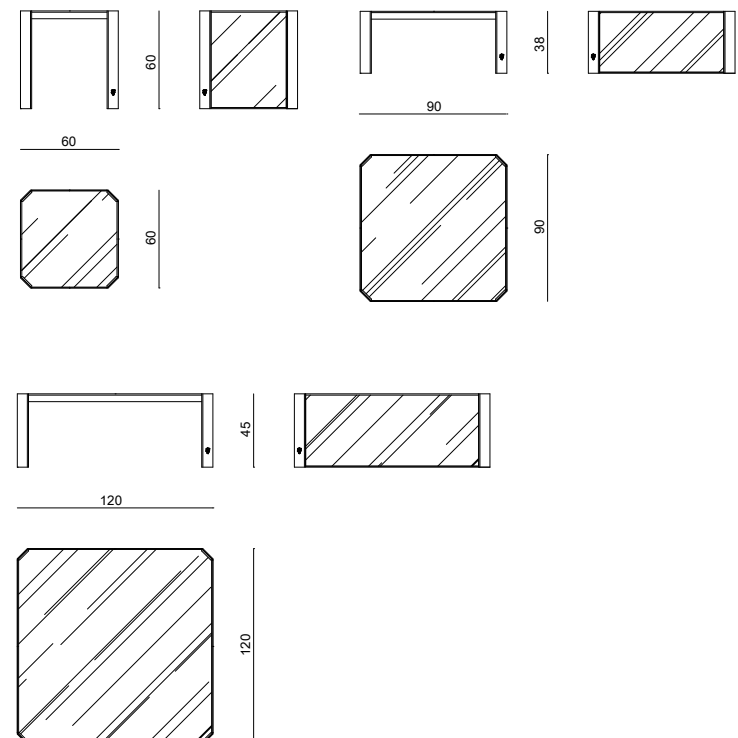

BUILDING

TAVOLO BASSO - LOW TABLE

Alessandro La Spada

Tavolino in marmo, struttura portante in legno rivestita in acciaio inox supermirror e base satinata. Il top in marmo è suddiviso in 5 parti con taglio in continuità di vena, con altezze diverse. I piani in marmo sono supportati da mensole in metallo. Le parti metalliche sono disponibili nella selezione finiture metalliche.

Table with marble tops. Main structure in wood covered in supermirror stainless steel and satin metal base. Top consisting in 5 vein-cut marble slabs positioned at different height. Marble tops are supported by metal shelves. Metal parts available in any lacquer of the metal finish selection.

● click here

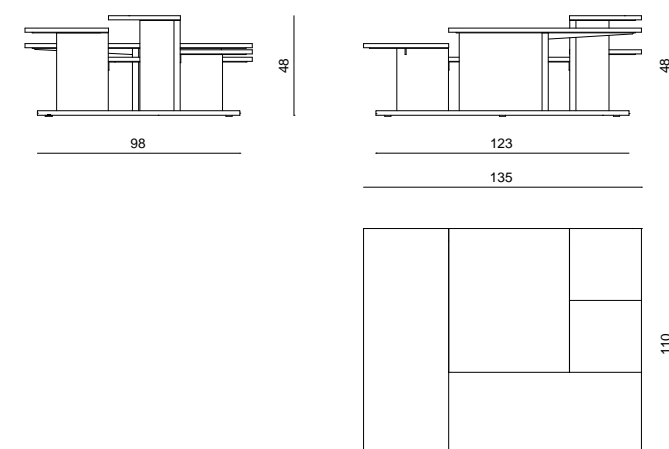



BREEZE INDOOR

TAVOLINO - SMALL TABLE

Roberto Tapinassi - Maurizio Manzoni

Tavolino a tre piedi in legno di frassino massello, con fregi e piedini in ottone inciso satinato. Top in vetro stratificato double-face con stampa digitale e sfondo nero e foglia oro o argento, retro nero. Gli accoppiamenti disponibili sono: libellula e foglia oro (top da Ø120 cm), coleottero nero e foglia oro oppure farfalla e foglia argento (top da Ø60 cm), coleottero verde e foglia argento oppure colibri e foglia argento (top da Ø50 cm), cervo volante e foglia argento oppure pesci lottatori e foglia oro (top da Ø40 cm). Struttura disponibile nelle tonalità "MAS" in finitura lucida 100 gloss. Le parti metalliche sono disponibili nella selezione finiture metalliche satiniate.

Three-foot table in ash solid wood, with decorations and feet in satinized engraved brass. Top in double face laminated glass with digital print, black background and gold or silver leaf, black rear back. The possible matchings are: dragonfly and gold leaf (top diam. 120 cm); black beetle and gold leaf or butterfly and silver leaf (top diam. 60 cm); green beetle and silver leaf or hummingbird and silver leaf (top diam. 50 cm); stag beetle and silver leaf or Siamese fighter fishes and gold leaf (top diam. 40 cm). Structure available in colours MAS 1, 2, 3, 4, 5 in 100 gloss shiny lacquer. Metal parts available in the finishes included in the satinized metal finishing selection.

vedi anche/see also BREEZE OUTDOOR tavolo basso, tavolini-low table, small table

● click here

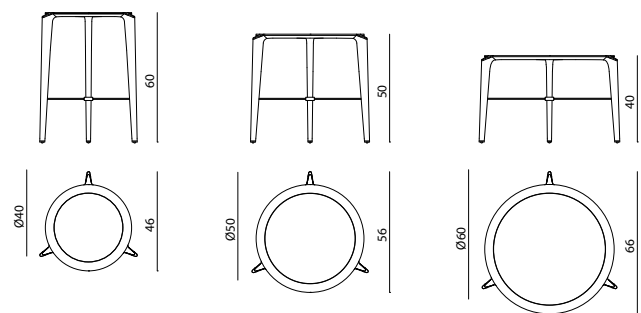

BUTTON

TAVOLO BASSO - LOW TABLE

Alessandro La Spada

Tavolino con doppio top in marmo, struttura metallica in acciaio lucido formata da tre elementi curvati a supporto dei piani in marmo lucidato a mano con bordo lavorato a mezzo toro inferiore. Le parti metalliche sono disponibili nella selezione finiture metalliche.

Table with dual top in marble, structure in polish stainless steel consisting of 3 curved elements supporting the hand-polished marble tops with upside-down half bullnose edge. Metal parts available in any lacquer of the metal finish selection.

● click here

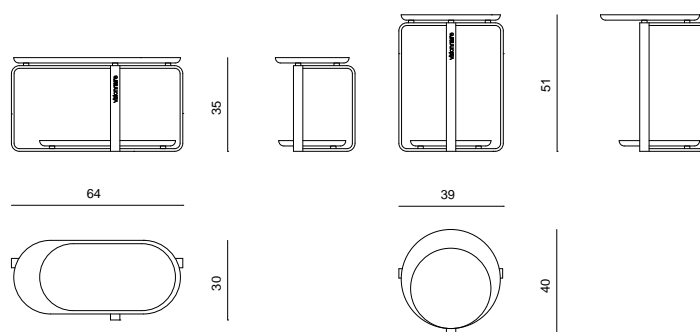

CHARLES

TAVOLO BASSO - LOW TABLE

Alessandro La Spada

Tavolo basso tappezzato in pelle o tessuto, top in marmo incassato in una cornice a sezione ellittica in ottone cromato, impreziosita da inserti con logo Visionnaire. Cerniera decorativa con cursori in pelle con logo, struttura interna in legno. Cerniere e cursori oro oppure cromo. Le parti metalliche sono disponibili nella selezione finiture metalliche.

Low table upholstered in leather or fabric, marble top built in a chromed-brass elliptical frame, enriched by inserts with Visionnaire engraved logo. Decorative zipper with sliders in leather with logo embroidered, internal structure in wood. Zippers and sliders in gold or chrome. Metal parts can be lacquered in any colour included in the metal finish selection.

● click here

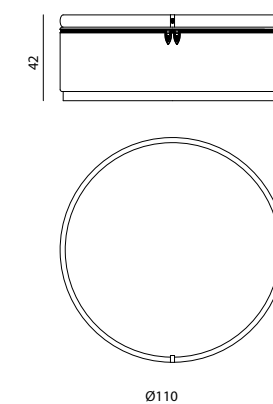



CYBORG LARGE

TAVOLO BASSO - LOW TABLE
Alessandro La Spada

Struttura in legno a pianta sfalsata con rivestimento esterno sagomato in acciaio inox satinato o pelle, base in acciaio inox satinato, top a doppia altezza in marmo o essenza nelle finiture selezione essenze, logo Visionnaire in acciaio applicato sul bordo verticale. Disponibile nelle varianti con top in legno e fianchi in acciaio satinato oppure pelle, o con top in marmo e fianchi in pelle. Le parti metalliche sono disponibili nella selezione finiture metalliche satinare.

Disponibile nella versione CYBORG LARGE RADICA con top rivestito in pelle e scocca esterna in radica con finitura lucida 100 gloss.

Structure in wood with staggered base with external shaped cover in satinized stainless steel or leather, base in satinized stainless steel, top with double height in marble or in veneered wood (available in the finishes included in the veneer selection), Visionnaire logo in steel applied on vertical profile. Two versions available: top in wood and laterals in satinized steel or leather, or top in marble and laterals in leather. Metal parts available in the satinized metal finishing selection.

Available in CYBORG LARGE RADICA version with upholstered in leather top and burr walnut outer shell with 100 gloss finish.

● click here



VERSIONE RADICA/ RADICA VERSION

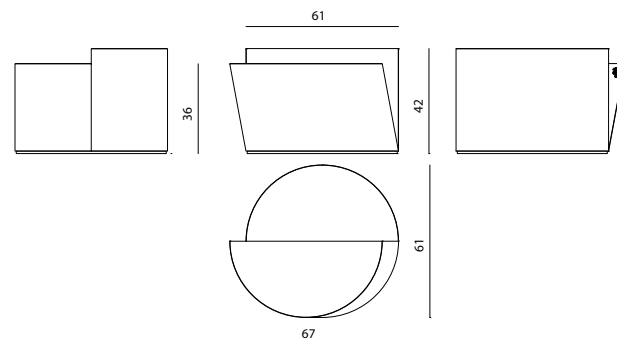

CYBORG HIGH

TAVOLINO - SMALL TABLE
Alessandro La Spada

Struttura in legno a pianta sfalsata con rivestimento esterno sagomato in acciaio inox satinato o pelle, base in acciaio inox satinato, top a doppia altezza in marmo o essenza nelle finiture selezione essenze, logo Visionnaire in acciaio applicato sul bordo verticale. Disponibile nelle varianti con top in legno e fianchi in acciaio satinato oppure pelle, o con top in marmo e fianchi in pelle. Le parti metalliche sono disponibili nella selezione finiture metalliche satinare.

Structure in wood with staggered base with external shaped cover in satinized stainless steel or leather, base in satinized stainless steel, top with double height in marble or in veneered wood (available in the finishes included in the veneer selection), Visionnaire logo in steel applied on vertical profile. Two versions available: top in wood and laterals in satinized steel or leather, or top in marble and laterals in leather. Metal parts available in the satinized metal finishing selection.

● click here

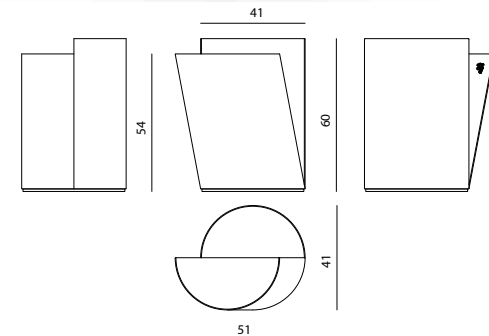

DOUGLAS

TAVOLINO - SMALL TABLE
Alessandro La Spada

Struttura in acciaio curvato e lucidato, top scatolato in legno sagomato e rivestito in essenza o laccato lucido (colori RAL/NCS). Le parti metalliche sono disponibili nella selezione finiture metalliche. Le parti in legno sono disponibili nelle finiture selezione essenze.

Structure in curved and polished steel, top in veneered or shiny lacquered shaped wood (RAL/NCS colours). Wooden parts available in the finishes included in the veneer selection; metal parts available in the satinized metal finishing selection.

vedi anche/see also DOUGLAS consolle-consolle, DOUGLAS divano,poltrona-sofa, armchair, DOUGLAS pouf-pouffe

● click here

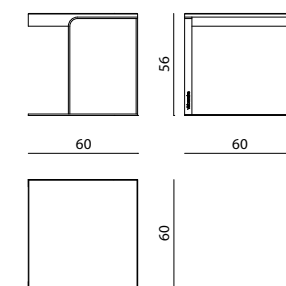

EGMONT

TAVOLO BASSO - LOW TABLE
Alessandro La Spada

Struttura in metallo e marmo, tre gambe in acciaio curvo con superficie interna lucida ed esterna satinata. Top in marmo parzialmente incassato con tre impronte in corrispondenza delle gambe. Opzione: top in marmo disponibile con finitura superficiale in micro-rilievo incisorio decorativo tipo Galuchat su marmo Black&Gold, lavorazione manuale curata da Diego Crestani.

Structure in metal and marble, three legs in curved steel with polish internal surface and satin external surface. Top in marble partially recessed in the three legs. When top is in Black&Gold marble, it can be finished with Galuchat micro-relief engraving, with manual processing by Diego Crestani.

● click here

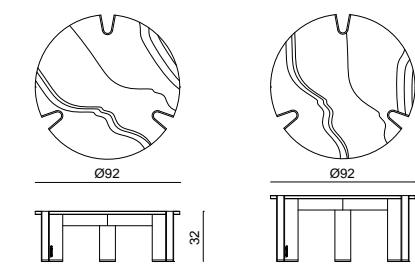
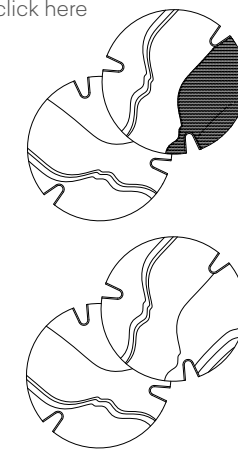

Marmi testurizzati disponibili: Colle Mandina con texture Serpente, Rain Forest con texture Linfa, Confusion Dark con texture Sea Waves, Port Laurent con texture Coccodrillo, Black&Gold con texture Galuchat.

Textured marble available: texture Snake on Colle Mandina, texture Linfa on Rain Forest, texture Sea Waves on Confusion Dark, texture Crocodile on Port Laurent, texture Galuchat on Black&Gold.



EGOISTE

TAVOLO BASSO - LOW TABLE

Alessandro La Spada

Tavolino con top in marmo, struttura metallica in acciaio satinato formata da quattro gambe connesse al centro con elementi ad arco. Top in marmo lucidato a mano con bordo lavorato a mezzo toro inferiore. Le parti metalliche sono disponibili nella selezione finiture metalliche satiniate.

Table with marble top, structure in satinized stainless steel consisting of 4 legs connected to the base by arc-shaped supporting elements. Top in hand-polished marble with upside-down half bullnose edge. Metal parts available in any lacquer of the satinized metal finish selection.

vedi anche/see also EGOISTE chaise-longue

● click here

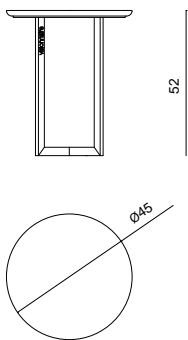

FOSTER

TAVOLO BASSO - LOW TABLE

Alessandro La Spada

Scocca in legno curvato "a ponte" rivestita in pelle. Finitura sui bordi con filetto in tinta. Top parzialmente in marmo con cornice sagomata in legno rivestita in pelle a contrasto, con bordino d'appoggio in metallo. Zoccoli di appoggio rivestiti in metallo, disponibile in colore cromo satinato, oro satinato e siena satinato.

Structure in curved "bridge-shaped" wood covered with leather. Finishing on the edges with piping in matching colour. Top partially covered in marble with shaped wooden frame covered with contrast leather, with metal support border. Supporting sockets covered in metal, available in satin chrome, satin gold and satin sienna.

vedi anche/see also FOSTER divano-sofa, poltrona-armchair, FOSTER dormeuse

● click here

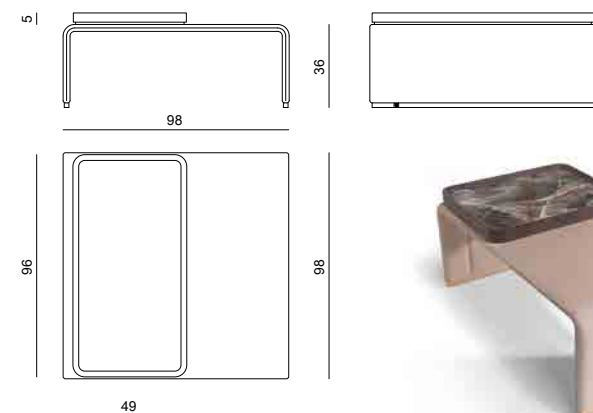
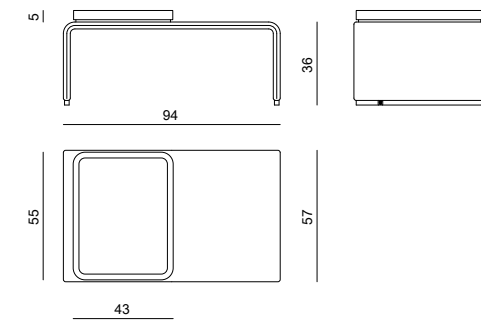

FITZGERALD

TAVOLO BASSO - LOW TABLE

La Conca

Tavolo basso in legno e marmo. Scocca esterna in multistrati di pioppo curvato e sagomato, impiallacciata in essenza con bordo in metallo su tutto il perimetro. Top in marmo a incasso parziale e ripiano inferiore in vetro fumé. Telaio portante interno in metallo verniciato a polveri. Le parti in legno sono disponibili lucide 100 gloss nelle finiture selezione essenze e in Radica. Le parti metalliche sono disponibili nella selezione finiture metalliche.

Low table in wood and marble. External structure in curved and shaped poplar plywood, coated in veneer and decorated with a metal profile framing the perimeter. Top in marble - partially built in the structure - and lower shelf in smoked glass. Internal supporting frame in powder-coated metal. Wooden parts available in any of the polished finishes included in the wood veneer selection or in Radica. Metal parts available in any of the lacquers included in the metal finish selection.

vedi anche/see also FITZGERALD divano-sofa

● click here

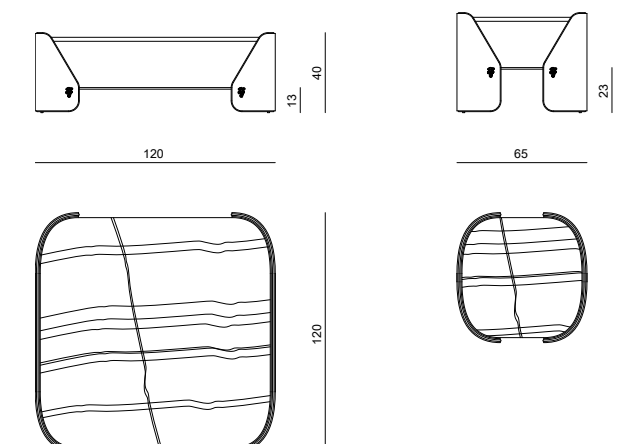

FRANKY

TAVOLO BASSO - LOW TABLE

Fabio Bonfà

Tavolo basso in acciaio e marmo. Telaio portante e basamento in acciaio inox tubolare di grande diametro e rivestimento in pelle. Sotto-top in legno laccato opaco e bordo sagomato in pelle con cuciture a due aghi ribattute sugli spigoli. Top incassato in marmo lucidato. Le parti metalliche sono disponibili nella selezione finiture metalliche.

Low table in steel and marble. Supporting frame and base in stainless steel with large tubular section and upholstery in leather. Undertop lacquered with mat finish and shaped edge covered in leather with double overlock stitching on the corners. Built-in top in polished marble. Metal parts available with polished and satin metal lacquered finish.

● click here

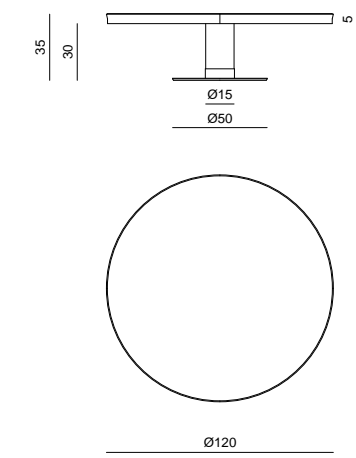



FRANKY

TAVOLINO - LOW TABLE

Fabio Bonfà

Tavolo basso in acciaio e marmo. Telaio e basamento in acciaio inox tubolare decentrato e rivestimento in pelle. Sotto-top in legno laccato opaco e bordo sagomato in pelle con cuciture a due aghi ribattute sugli spigoli. Top incassato in marmo lucidato. Le parti metalliche sono disponibili nella selezione finiture metalliche.

Low table in steel and marble. Frame and off-centred base in tubular stainless steel and upholstery in leather. Undertop lacquered with mat finish and shaped edge covered in leather with double overlock stitching on the corners. Built-in top in polished marble. Metal parts available with polished and satin metal lacquered finish.

● click here

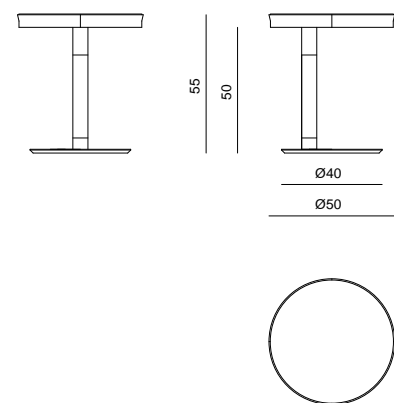

GEORG

TAVOLO BASSO - LOW TABLE

Giuseppe Viganò

Struttura in MDF laccato lucido 100 gloss (colori RAL/NCS) con inserti verticali in barra di ottone naturale. Bordo top e base superiore in acciaio inox lucidato oppure laccato nella selezione finiture metalliche. Top a semi-incasso in marmo bisellato, base a terra in marmo.

Structure in lacquered and polished 100 gloss MDF (RAL/NCS colours) with vertical inserts on natural brass stem. Top edge and upper base in polished stainless steel, available in the metal finishing selection. Built-in top in bevelled marble, base in marble.

● click here

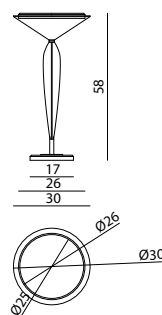

GRANGER

TAVOLI BASSI TRITTIKO - SET OF 3 LOW TABLES

Alessandro La Spada

Trittico di tavolini a diverse altezze con struttura in acciaio inox con superfici concave e convesse. La gamba in acciaio lucido è disposta fuori centro con un lato concavo che termina con una lavorazione nel top in marmo della stessa forma. Il top in marmo, lucidato e bisellato nel lato inferiore, è disponibile anche nella versione "invisible grey marble - leather finishing" con trattamento superficiale manuale di verniciatura decorativa in oro, bronzo o manganese. Le parti in metallo sono disponibili nelle selezioni finiture metalliche lucide. Disponibili anche singolarmente.

Opzione: la decorazione in oro liquido con finitura a cera può essere eseguita solo su Invisible Grey, Black & Gold, Ivory Onyx, Velvet Onyx.

Set of 3 low tables in different sizes, structure in stainless steel with concave and convex shapes. Off-centre table leg in shiny steel with one concave side, terminating into the top with a concave curve. Top in polished marble with bevelled lower part, available in "invisible grey marble-leather finish" version decorated with gold, bronze or manganese hand-lacquer finish. Metal parts can be finished with any lacquer of the polished metal lacquer finish selection.

Option: gold liquid decoration with wax finishing can be done only on Invisible Grey, Black&Gold, Ivory Onyx, Velvet Onyx.

● click here

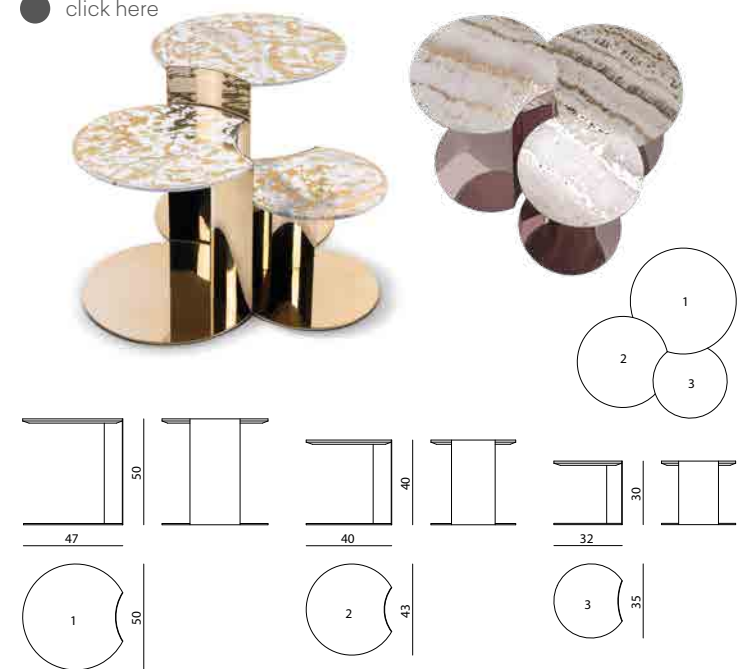

HANSEL

TAVOLINI - SMALL TABLES

Samuele Mazza

Basamento in acciaio inox, stelo in acciaio cromato, sotto top in acciaio, top in onice bianco o miele realizzato da unico blocco, retro illuminazione a LED.

Base in stainless steel, support in chromed steel, undertop in steel, top in honey or white onyx marble obtained from a single block, with LED back-lighting.

● click here

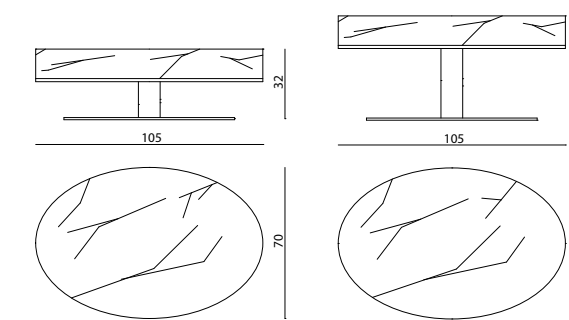



HAVOK

TAVOLINO - SMALL TABLE

Giuseppe Viganò

Struttura portante e sottotop in legno rivestito in pelle, piedi in metallo rivestito in legno massello tinto, disponibile nelle varianti "MAS". Top ellittico in marmo.

Main structure and undertop in wood upholstered in leather, feet in steel covered in solid wood stained in "MAS" colours. Elliptical top in marble.

● [click here](#)



JAMBOREE

TAVOLINO - LOW TABLE

Alessandro La Spada

Tavolo basso in marmo o legno laccato. Versione in legno: Struttura in legno laccato lucido (colori RAL/NCS) da 50mm con angoli spioventi. Gambe in acciaio inox sciolato con sagoma a coda di rondine avviate sotto il top. Versione in marmo: Struttura interna in legno rivestita in lastra di marmo sciolata con angoli spioventi. Gambe in acciaio inox sciolato con sagoma a coda di rondine avviate sotto il top. Le parti in metallo sono disponibili nella selezione finiture metalliche.

Low table in marble or lacquered wood. Version in wood: Structure in wood with shiny lacquer finish (RAL/NCS colours), 50 mm thick, and sloped corners. Legs in tubular stainless steel with dove-tail shape are connected to the top using screws. Version in marble: Internal structure in wood covered with slab of marble with sloped corners. Legs in tubular steel with dove-tail shape are connected to the top using screws. Metal components can be finished with any lacquer of the metal lacquer finish selection.

vedi anche/see also JAMBOREE divano, poltrona-sofa, armchair, JAMBOREE poltroncina-armchair

● [click here](#)

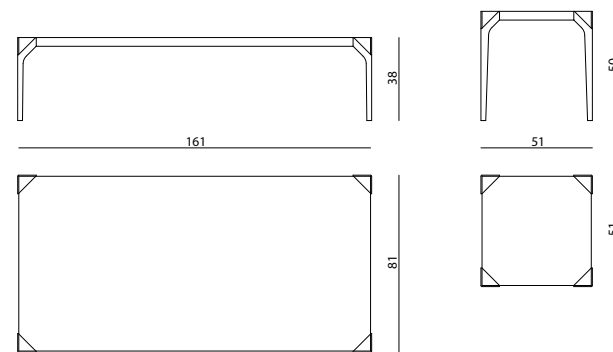

HORIZON FLAT

TAVOLO BASSO - LOW TABLE

Alessandro La Spada

Struttura in legno massello, gambe rivestite esternamente in pelle o essenza, internamente in acciaio satinato. Cornice sottotop rivestita in pelle o essenza, top in marmo con profilo perimetrale in acciaio inox satinato. Le parti in legno sono disponibili nelle finiture selezione essenze; le parti metalliche sono disponibili nella selezione finiture metalliche satinato.

Structure in solid wood, legs externally upholstered in leather or veneered, internally covered in satinized steel. Undertop frame upholstered in leather or veneered, top in marble with perimetral profile in satinized stainless steel. Wooden parts available in the finishes included in the veneer selection; metal parts available in the satinized metal finishing selection.

vedi anche/see also HORIZON consolle-console, HORIZON madia-cabinet

● [click here](#)

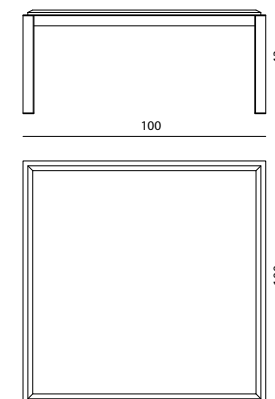

HORIZON TRAY

TAVOLO BASSO - LOW TABLE

Alessandro La Spada

Struttura in legno massello di frassino rivestito in essenza o pelle, bordo top e interno gambe in acciaio inox satinato. Top composto nelle parte principale da marmo o da un pannello rivestito in pelle o tessuto, abbinato a un pannello rivestito in essenza con fregio metallico a filo top ed un vassoio portaoggetti in legno rivestito in essenza. Le parti in legno sono disponibili nelle finiture selezione essenze; le parti metalliche sono disponibili nella selezione finiture metalliche satinato.

Structure in ash solid wood covered in veneered wood or leather, top edge and inside legs in satinized stainless steel. Top made of marble or panel upholstered in leather or fabric, combined with a panel covered in veneered wood with metal frieze built-in the top and a storage tray in wood covered in veneer. Wooden parts available in the finishes included in the veneer selection; metal parts available in the satinized metal finishing selection.

vedi anche/see also HORIZON consolle-console, HORIZON madia-cabinet

● [click here](#)

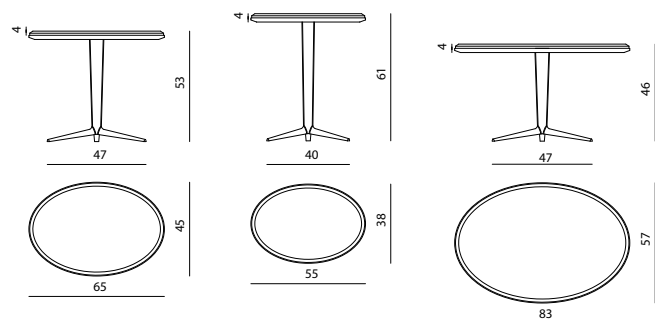
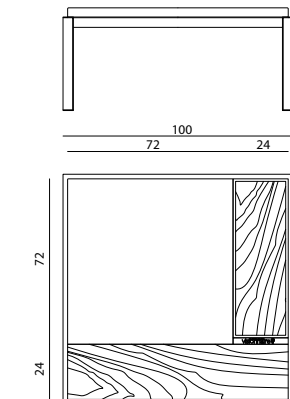



KENAZ

TAVOLINO BASSO - LOW TABLE

Steve Leung

Stelo in fusione di alluminio satinato sagomato a forma di chiocciola, sotto-top in legno laccato lucido e top in marmo o semi-prezioso a incasso. Stelo disponibile in finitura satinata oro, bronzo, argento o nichel nero.

Base in snail shaped satinized aluminium cast. Under-top in polish lacquered wood and top in marble or semi-precious stone. The base is also available in mat gold, bronze, silver or black nickel colours.

● [click here](#)

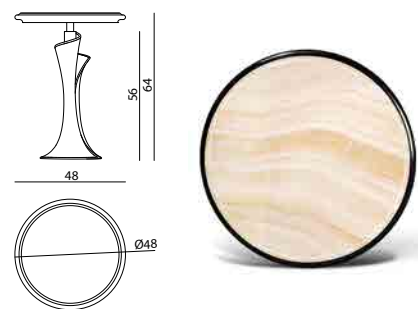

KINGS CROSS

TAVOLO BASSO - LOW TABLE

Mauro Lipparini

Tavolo basso, struttura portante in legno massello di noce canaletto con finitura naturale a poro aperto, scolpito con sezione sagomata a tre lobi, ripiano inferiore in legno verniciato RAL/NCS lucido o rivestito in pelle o tessuto. Top in marmo in appoggio disponibile con vassoio portaoggetti rivestito in pelle o tessuto.

Low table. Supporting frame in Canaletto walnut solid wood with open-pore natural finish and shaped three-lobes section. Lower shelf in wood with shiny RAL/NCS lacquer finish or upholstery in leather/fabric. Top in marble available with optional storage tray upholstered in leather or fabric.

vedi anche/see also KINGS CROSS pouf-pouffe, KINGS CROSS console-console, KINGS CROSS mobile basso-low cabinet, KINGS CROSS cassettiera-chest of drawers, KINGS CROSS mobile trucco-make-up unit

● [click here](#)

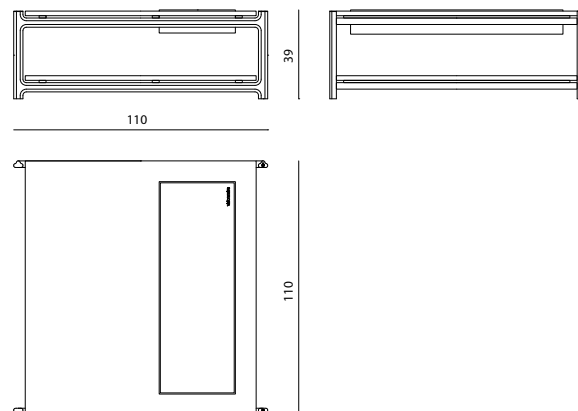

KINGS CROSS

TAVOLO BASSO - LOW TABLE

Mauro Lipparini

Tavolo basso, struttura portante in legno massello di noce canaletto con finitura naturale a poro aperto, scolpito con sezione sagomata a tre lobi, ripiano inferiore in legno verniciato RAL/NCS lucido. Top in marmo in appoggio.

Low table. Supporting structure in Canaletto walnut solid wood with open-pore natural finish and shaped three-lobes section. Lower shelf in wood with shiny RAL/NCS lacquer finish. Top in marble.

vedi anche/see also KINGS CROSS pouf-pouffe, KINGS CROSS console-console, KINGS CROSS mobile basso-low cabinet, KINGS CROSS cassettiera-chest of drawers, KINGS CROSS mobile trucco-make-up unit

● [click here](#)

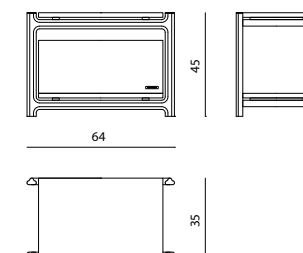

KINGS CROSS

TAVOLINO TONDO - ROUND LOW TABLE

Mauro Lipparini

Tavolo basso tondo, struttura portante in legno massello di noce canaletto con finitura naturale a poro aperto, scolpito con sezione sagomata a tre lobi, ripiano inferiore in legno verniciato RAL/NCS lucido o rivestito in pelle. Top in marmo incassato.

Round low table. Supporting frame in Canaletto walnut solid wood with open-pore natural finish and shaped three-lobes section. Lower shelf in wood with shiny RAL/NCS lacquer finish or upholstery in leather. Flush-mounted marble into top structure.

vedi anche/see also KINGS CROSS pouf-pouffe, KINGS CROSS console-console, KINGS CROSS mobile basso-low cabinet, KINGS CROSS cassettiera-chest of drawers, KINGS CROSS mobile trucco-make-up unit

● [click here](#)

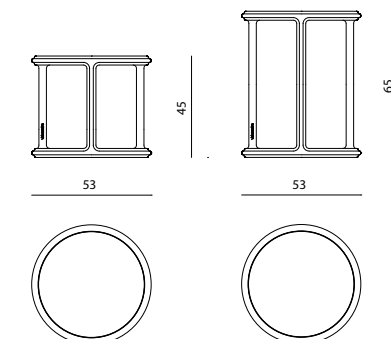



KORVAC

TAVOLO BASSO - LOW TABLE

Fabio Bonfà

Tavolo basso in acciaio e marmo. Telaio portante e basamento in acciaio inox tubolare di grande diametro. Top in marmo con bordo sagomato a mezzo toro e sotto-top in legno laccato lucido con bordo a mezzo toro con profilo metallico di separazione con fibbie decorative in ottone cromato con logo inciso. Vano sotto-top dotato di due cassetti rivestito in pelle con cuciture sugli spigoli e loghi in ottone cromato. Le parti metalliche sono disponibili nella selezione finiture metalliche.

Low table in steel and marble. Supporting frame and base in stainless steel with large tubular section. Top in marble with shaped half bullnose edge and undertop in polished lacquered wood with half bullnose edge, metal divisory profile equipped with chromed brass buckles with engraved logo. Undertop compartment provided with 2 drawers upholstered in leather with stitching on the edges and chromed brass logos. Metal parts available with polished or satin lacquered finish.

● click here

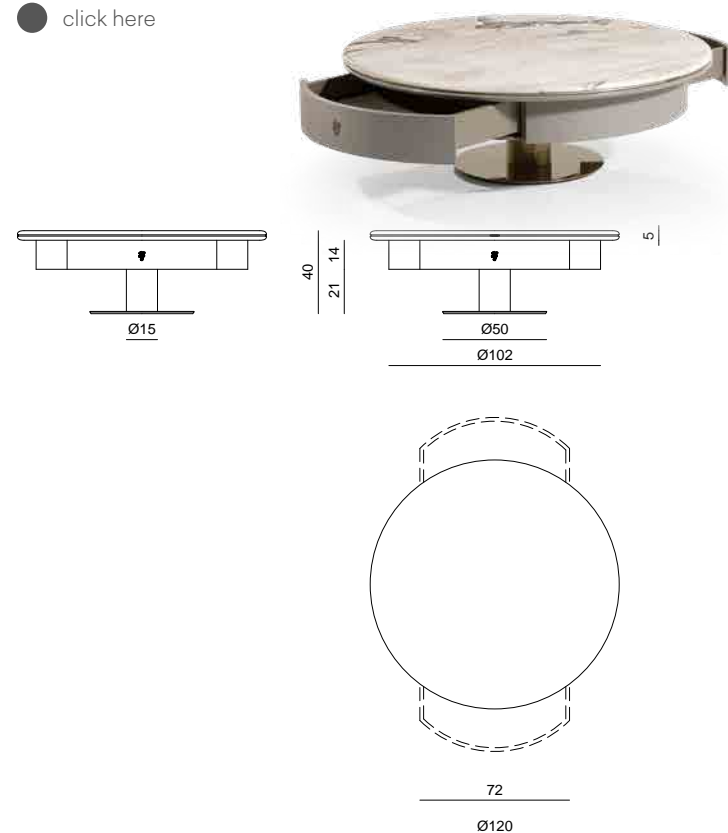

LEGO

TAVOLO BASSO - LOW TABLE

Marco Draga&Aurel

Struttura portante in cemento e alluminio. La parte in cemento armato è lavorata con trattamento di erosione e colorazione nero opaco. Le parti in alluminio sono realizzate per fusione in sabbia con texture ondulata, lucidata e pigmentata a mano, disponibili nella selezione finiture metalliche. I due elementi possono essere montati in tre diverse configurazioni.

Main structure in concrete and aluminium. The concrete part is worked with an aged surface and painted in mat black. Aluminium part is made by sand casting, textured, polished and lacquered by hand in any colour of the metal finish selection. The two elements can be mounted in three different configurations.

vedi anche/see also LEGO consolle-console

● click here

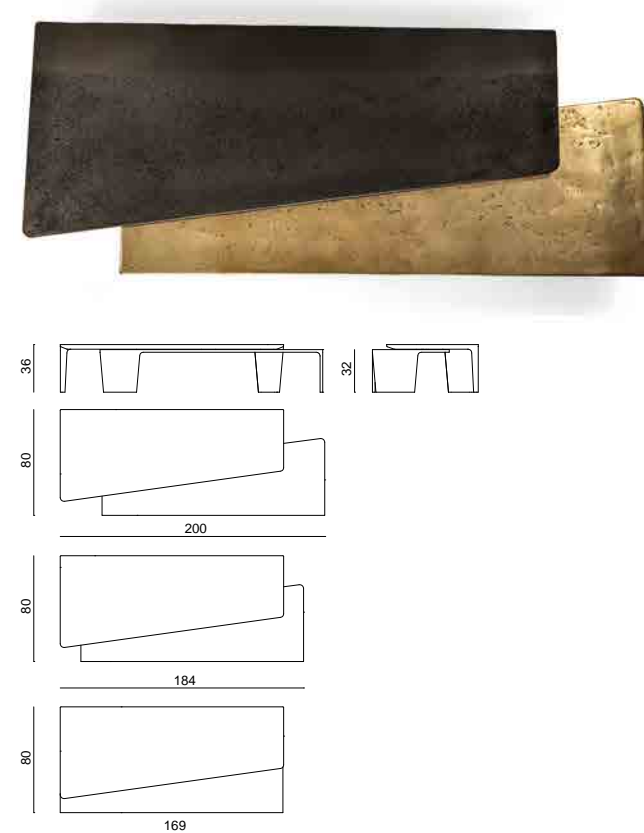

MARTY

TAVOLO BASSO - LOW TABLE

Marco Piva

Tavolo basso composto da tre basamenti rivestiti in marmo e acciaio inox satinato. Top in cristallo fumé sp. 8 mm scatola tramite saldatura UV. Ulteriori top di finitura in marmo e acciaio inox satinato a materiali alterni in corrispondenza delle basi. Le parti in metallo sono disponibili nella selezione finiture metalliche satinato.

Coffee table composed of three bases covered in marble and satin stainless steel. Smoked crystal top th. 8 mm boxed by UV bonding. Additional finishing tops in marble and stainless steel with alternating materials at the bases. The metal parts are available in the metal satinized finishing selection.

vedi anche/see also MARTY consolle-console

● click here



MILLER

TAVOLINO - COFFEE TABLE

Fabio Bonfà

Tavolo basso con top in marmo bicolore e bordo smussato. Base in legno rivestita in tessuto Gand, Faber o Vermeer trapuntato "canneté", profili metallici e fibbia con logo in metallo disponibili nei colori cromo lucido, oro lucido e nichel nero satinato.

Low table with bicolour marble top with rounded edges. Base in wood covered with Gand, Faber or Vermeer fabric quilted with canneté decorative motif. Metal profiles and buckle with metal logo available with polish chrome, polish gold or satin black nickel finish.

vedi anche/see also MILLER divano-sofa

● click here





MINSTREL

TAVOLINO - COFFEE TABLE

Alessandro La Spada

Tavolino con corpo centrale in legno rivestito in essenza, disponibile nelle finiture selezione essenze. Base in acciaio inox satinato con logo Visionnaire, disponibile nella selezione finiture metalliche satinato.

Disponibile nella versione MINSTREL RADICA con corpo centrale in radica con finitura lucida 100 gloss.

Low table with central part in wood covered in veneer, available in the veneer selection finishings. Base in satinized stainless steel with Visionnaire logo, available in the satinized metal finishing selection.

Available in the MINSTREL RADICA version with central body in burr walnut with 100 gloss finish.

● click here



VERSIONE RADICA/RADICA VERSION

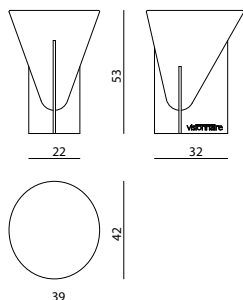

MONDRIAN

TAVOLO BASSO - LOW TABLE

Fabio Bonfà

Tavolo basso. Telaio in acciaio satinato a sezione quadrata con saldature invisibili e ripiano inferiore in marmo diviso in più parti, con taglio in continuità di vena. Top in cristallo extra chiaro o fumè. Le parti in metallo sono disponibili nella selezione finiture metalliche.

Opzione: texture "Linfa" su marmo Rainforest, con lavorazione manuale curata da Diego Crestani

Low table. Squared frame in satin steel with invisible welded joints; lower shelf in vein-cut marble divided into several sections. Top in extra clear or smoked crystal glass. Metal details can be finished with any lacquer of the metal lacquer finish selection.

Option: texture "Linfa" on Rainforest marble, with manual processing by Diego Crestani.

vedi anche/see also MONDRIAN consolle-console

● click here

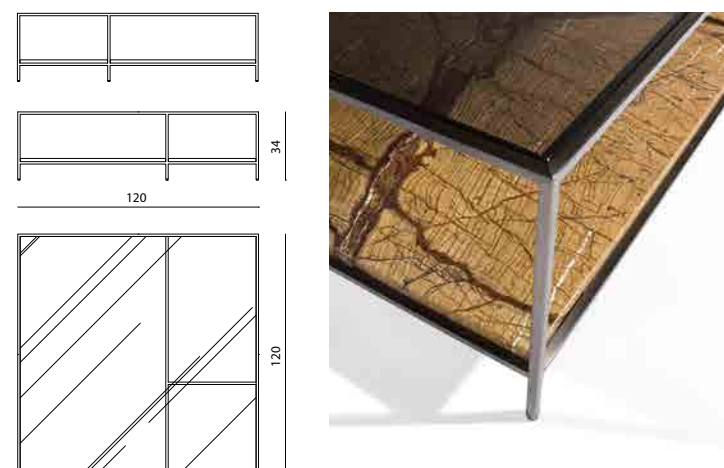

Marmi testurizzati disponibili: Colle Mandina con texture Serpente, Rain Forest con texture Linfa, Confusion Dark con texture Sea Waves, Port Laurent con texture Coccodrillo, Black&Gold con texture Galuchat.

Textured marble available: texture Snake on Colle Mandina, texture Linfa on Rain Forest, texture Sea Waves on Confusion Dark, texture Crocodile on Port Laurent, texture Galuchat on Black&Gold.



ORBITAL

TAVOLINO - COFFEE TABLE

Mauro Lipparini

Tavolo basso tondo in legno laccato con vano porta-oggetti impiallacciato in essenza, munito di vassoio accessorio in marmo, sospeso su un supporto in metallo rotante all'interno del vano porta-oggetti. Vassoio in marmo scolpito con bordo tondo a rilievo. Le parti metalliche sono disponibili nella selezione finiture metalliche.

Low round table in lacquered wood with wood veneered storage compartment, equipped with a marble tray, suspended on a rotating metal support inside the storage compartment. Carved marble tray with round edge in relief. Metal parts available in the metal finishing selection.

● click here

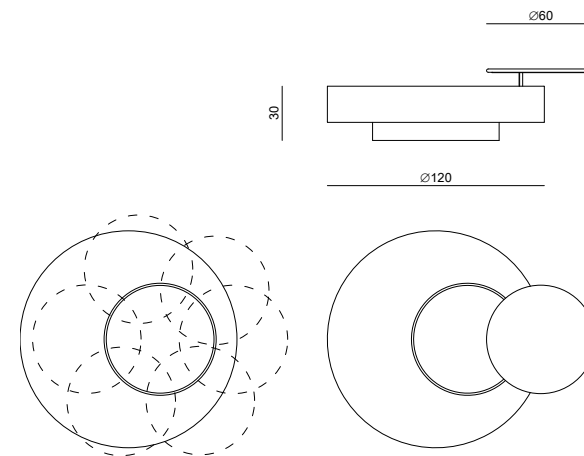

PELLEAS

TAVOLO BASSO - LOW TABLE

Alessandro La Spada - Samuele Mazza

Struttura in compensato multistrati. Rivestimento in vetro bisellato su tutti i lati, disponibile nei colori di serie. Vasca interna rivestita in vetro a specchio. Zoccolo di base in acciaio inox lucido. Opzionale: vaschette, a tenuta stagna, in plexiglass con maniglie in acciaio (max nr. 2 per tavolo).

Structure in plywood. Cover in bevelled glass on all the sides, available in the colours included in the Visionnaire collection. Internal basin covered in mirror. Plinth in shiny stainless steel. Optional: water-tight basins in plexiglass with stainless steel handles (max. no. 2 for each table).

● click here

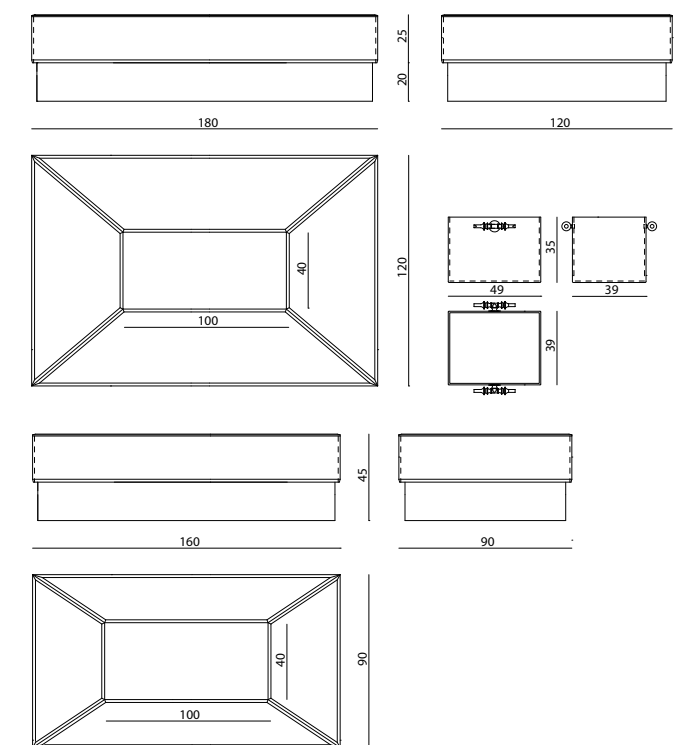



RUBEN

TAVOLINO BASSO - LOW TABLE

Steve Leung

Tavolino basso in marmo. Top in marmo a due toni a mosaico con disegno ad archi e inserti decorativi in ottone levigato a filo marmo. Telaio portante a vista in massello di frassino tinto formato da una cornice sagomata e tre piedi conici raccordati alla cornice, muniti di basette in acciaio.

Low table in marble. Two-tone marble mosaic top with arched design and decorative inserts in polished brass flush with marble. Visible supporting frame in solid stained ash formed by a shaped frame and three conical feet connected to the frame, fitted with steel bases.

● [click here](#)

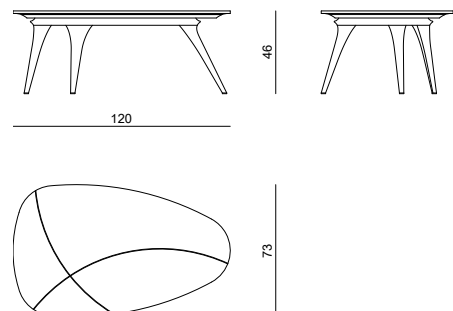

RUIS

TAVOLO BASSO - LOW TABLE

Alessandro La Spada - Samuele Mazza

Struttura in compensato multistrati. Rivestimento top e fianchi in marmo. Vasca interna e zoccolo di base rivestiti in metallo lucido. Optional: vaschette, a tenuta stagna, in plexiglass con maniglie in acciaio (max n. 2 per tavolo).

Structure in plywood. Top and sides in marble. Internal basin and base cornice covered in polished metal. Optional: waterproof basins in plexiglass with stainless steel handles (max. 2 for table).

● [click here](#)

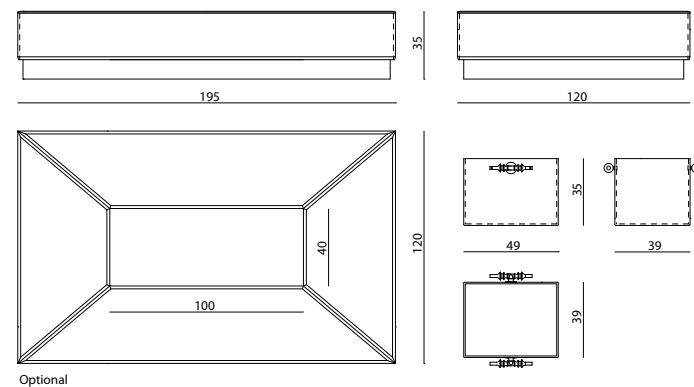

RUPERT

TAVOLO BASSO - LOW TABLE

Roberto Lazzeroni

Tavolino basso ovale con top in fibra di legno lavorata dal pieno in forma organica con finitura laccata 100 gloss. Vano porta oggetti ricavato nel piano superiore. La parte inferiore del top, di sagoma eccentrica, confluisce in una base conica in marmo massiccio, scavato da unico blocco. Basetta di appoggio in acciaio satinato.

Oval low table with top in wood fibergraven organic form with 100 gloss lacquered finish. Object compartment in the top. The lower part, of eccentric shape, flows into a conical base in solid marble, milled from a single block. Support base in brushed steel.

● [click here](#)

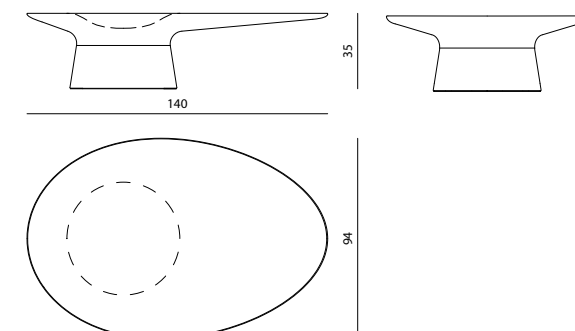

RYLAN

TAVOLO BASSO - LOW TABLE

Mauro Lipparini

Tavolo basso ovale con basamento obliquo in legno rivestito in acciaio inox satinato. Top obliquo girevole in legno laccato lucido a colori RAL. Il top può ruotare di 360° con fermi in due posizioni (aperto/chiuso). Le parti in acciaio sono disponibili nella selezione finiture metalliche.

Oval coffee table with wooden oblique stand covered in satin stainless steel. Swivel oblique top in glossy lacquered wood (available in RAL colours). The top can rotate 360° with stops in two positions (open/closed). Metal parts available in the metal finishing selection.

● [click here](#)

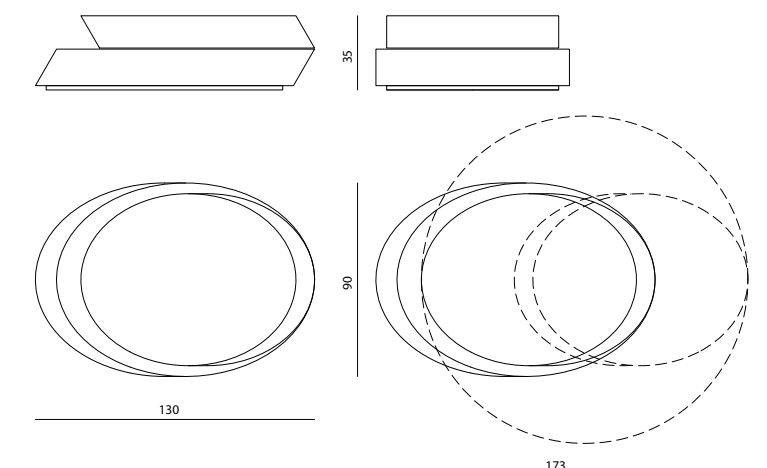



SARIN

TAVOLO BASSO - LOW TABLE

Steve Leung

Tavolo basso in marmo. Top in marmo a due toni a mosaico con disegno ad archi e inserti decorativi in ottone levigato a filo marmo. Base a stelo in massello di frassino tinto.

Low table in marble. Marble top in two-tone mosaic with arched design and decorative inserts in polished brass flush with marble. Pedestal base in solid stained ash.

● [click here](#)



SOWILO

TAVOLO BASSO - LOW TABLE

Steve Leung

Base a forma organica in resina nautica con finitura in vernice metallica (bronzo, oro, manganese) lucida, top in marmo a incasso oppure in resina artistica a campionario. Cornice top e base in acciaio inox lucidato disponibile nella selezione finiture metalliche.

Base with organic shape in nautical resin finished with polished metal varnish (bronze, gold, manganese). Built-in marble top or artistic resin from sample book. Top and base profile in polished stainless steel available in any finish included in the metal finish selection.

● [click here](#)



SOWILO HIGH

TAVOLINO - SMALL TABLE

Steve Leung

Base a forma organica in resina nautica con finitura in vernice metallica (bronzo, oro, manganese) lucida, top in marmo a incasso oppure in resina artistica a campionario. Cornice top e base in acciaio inox lucidato disponibile nella selezione finiture metalliche.

Base with organic shape in nautical resin finished with polished metal varnish (bronze, gold, manganese). Built-in marble top or artistic resin from sample book. Top and base profile in polished stainless steel available in any finish included in the metal finish selection.

● [click here](#)



SOLSTICE

TAVOLINO - SMALL TABLE

Alessandro La Spada

Struttura sagomata a gabbia, su base circolare in acciaio inox taglio laser. Base e sottotop in acciaio inox. Top in marmo. Le parti metalliche sono disponibili nella selezione finiture metalliche.

Cage structure on rounded stainless steel laser cut base. Base and under-top in stainless steel. Top in marble. Metal parts can be lacquered in any colour of the metal finish selection.

vedi anche/see also SOLSTICE tavolo da pranzo-dining table, SOLSTICE tavolo pranzo dehors-dining table dehors

● [click here](#)

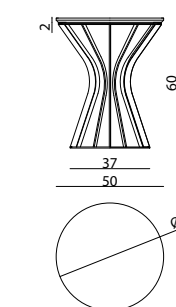
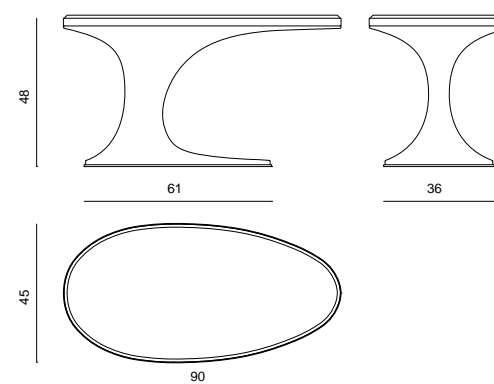
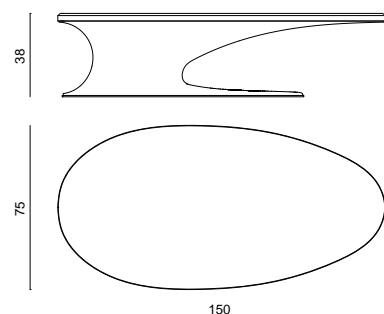
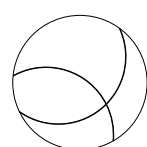
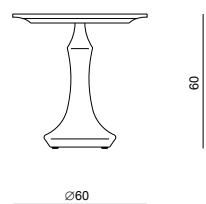



STINGER

TAVOLINO - SMALL TABLE

Alessandro La Spada

Struttura portante in legno con rivestimento laterale in acciaio inox satinato e pelle, base in pelle con trapuntatura cannettata. Top con rivestimento in pelle. Opzione: gli elementi metallici sono disponibili satinati nella selezione finiture metalliche.

Main structure in wood with side covered in satinized stainless steel and leather, base in leather with canneté quilting. Top covered in leather. Option: metal parts available in the finishes included in the metal finishing selection.

● click here

TANGUY

TAVOLI BASSI - LOW TABLES

Domenico De Palo

Base in acciaio inox lucidato con log hi in ottone inciso, intarsio a filo top in acciaio inox lucidato, piano in multistrati curvato di grande spessore laccato 100 gloss o impiallacciato in essenza. Parti in metallo disponibili nella selezione finiture metalliche.

Polished stainless steel base with logo engraved in brass, inlay top in polished stainless steel. Curved plywood top lacquered in 100 gloss or veneered. Metal parts available in any colour included in the metal finish selection.

● click here

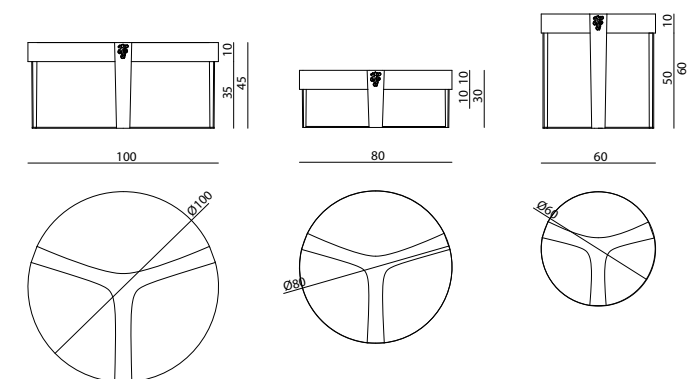

TRAPEZE

TAVOLO BASSO - LOW TABLE

La Conca

Tavolo basso in marmo e legno laccato. Top in marmo lucido con bordo sagomato a mezzo toro e sotto-top in HPL ad alta resistenza. Top inferiore in legno laccato lucido (colori RAL/NCS), bordo a mezzo toro e logo Visionnaire in ottone cromato leggermente incassato. Quattro piedi in acciaio inox con elementi tubolari sovrapposti. Le parti metalliche sono disponibili nella selezione finiture metalliche. Disponibile anche con top inferiore in marmo a contrasto.

Low table in marble and lacquered wood. Top in polished marble with shaped half bullnose edge and undertop in HPL with high resistance. Lower top in polish lacquered wood (RAL/NCS colours), shaped half bullnose edge and Visionnaire logo in chromed brass slightly embedded in the structure. 4 feet in stainless steel with overlying tubular elements. Metal parts available in polished and satin metal finish. Also available with lower top in contrasting marble.

● click here

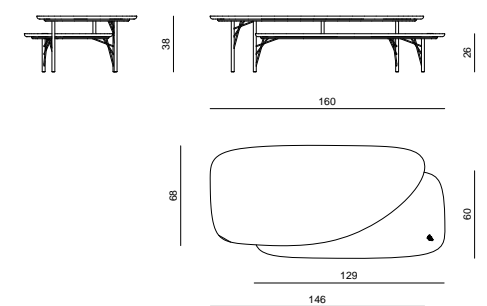

TRAPEZE

TAVOLINO - SMALL TABLE

La Conca

Tavolo basso in marmo e legno laccato. Top in marmo lucido con bordo sagomato a mezzo toro e sotto-top in HPL ad alta resistenza. Top inferiore in legno laccato lucido (colori RAL/NCS), bordo a mezzo toro e logo Visionnaire in ottone cromato leggermente incassato. Tre piedi in acciaio inox con elementi tubolari sovrapposti. Le parti metalliche sono disponibili nella selezione finiture metalliche. Disponibile anche con top inferiore in marmo a contrasto.

Low table in marble and lacquered wood. Top in polished marble with shaped half bullnose edge and undertop in HPL with high resistance. Lower top in polish lacquered wood (RAL/NCS colours), shaped half bullnose edge and Visionnaire logo in chromed brass slightly embedded in the structure. 3 feet in stainless steel with overlying tubular elements. Metal parts available in polished and satin metal finish. Also available with lower top in contrasting marble.

● click here

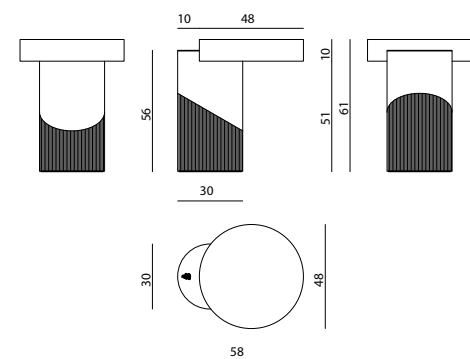
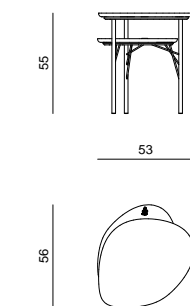



VINCENT

TAVOLO BASSO - LOW TABLE

Alessandro La Spada

Tavolo basso con struttura in tubi metallici cromati curvati e uniti tra loro. Versione con top in vetro: lastra di vetro fumè da 12 mm con bordo bisellato, la base è collegata al top tramite supporti in alluminio e acciaio inox saldati a UV. Versione con top in marmo: lastra di marmo da 20 mm con bordo bisellato e bussole di fissaggio inferiore. Le parti in metallo sono disponibili nella selezione finiture metalliche, il vetro del top è disponibile nelle varianti fumè, bronzo, extrachiaro.

Low table with structure in chromed metal tubes curved and welded together. Version with glass top: sheet of smoked glass, 12 mm in thickness, with bevelled edge; aluminium and steel supports for base bonded to top using UV light. Version with marble top: marble slab, 20 mm in thickness, with bevelled edge and equipped with liner jig bushes. Metal parts can be finished with any lacquer of the metal lacquer finish selection. Glass top available with smoked, bronze or extra clear finish.

vedi anche/see also VINCENT consolle-console

● click here

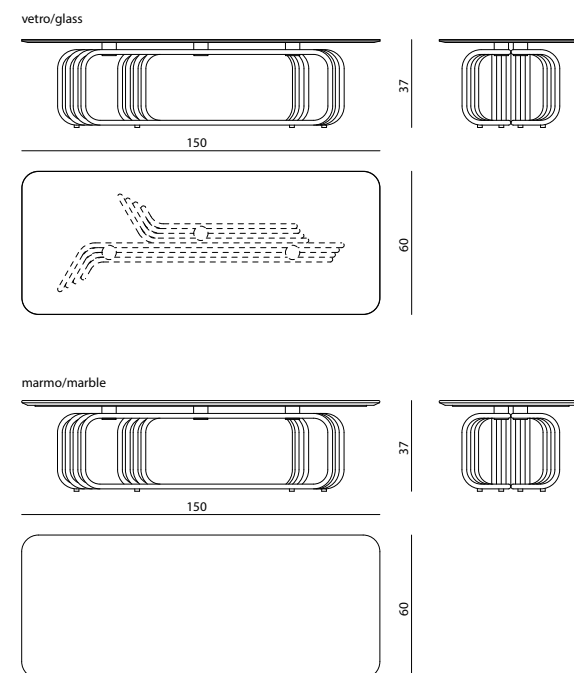

WOODY

TAVOLO BASSO - LOW TABLE

La Conca

Tavolo basso con cassetti, struttura in legno rivestito in specchio satinato con bordi bisellati lucidi, interni laccati RAL/NCS opaco. Lo specchio del rivestimento è disponibile nei colori naturale, bronzo e fumè.

Low table with drawers, structure in wood covered in satin mirror glass with polished bevelled edges, internally lacquered with matt RAL/NCS colours. Mirror glass available with natural, bronze or smoked finish.

vedi anche/see also WOODY cassetiera-chest of drawers, MIDNIGHT madia, mobile basso-cabinet, low cabinet

● click here

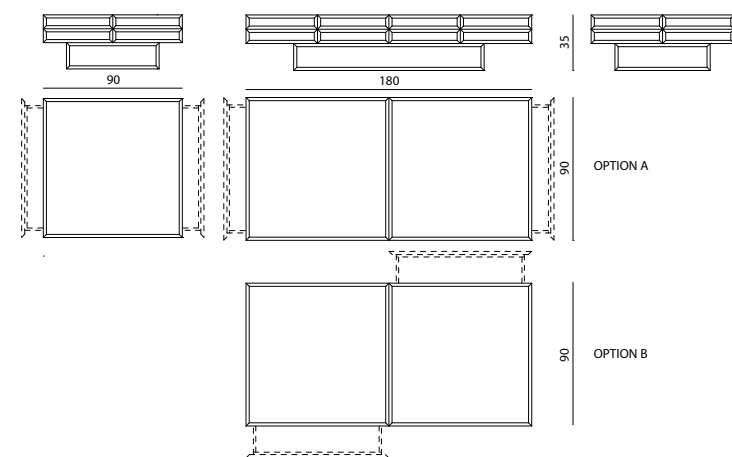



CHANTILLY

TAVOLI BASSI TRITTICO - SET OF 3 LOW TABLES
Alessandro La Spada

Base in fusione di alluminio con logo in ottone, gamba in tornerie di alluminio e acciaio cromato, sotto-top in MDF laccato lucido sagomato, top in marmo bisellato. Parti in metallo disponibili nella selezione finiture metalliche.

Base in fusion of aluminium with Visionnaire logo in brass, legs in turned aluminium and chromed steel moulded, undertop in lacquered shiny MDF, top in marble. Metal parts available in any colour included in the metal finish selection.

vedi anche/see also CHANTILLY consolle-console, CHANTILLY cache-pot, CHANTILLY vaso-vase

● click here

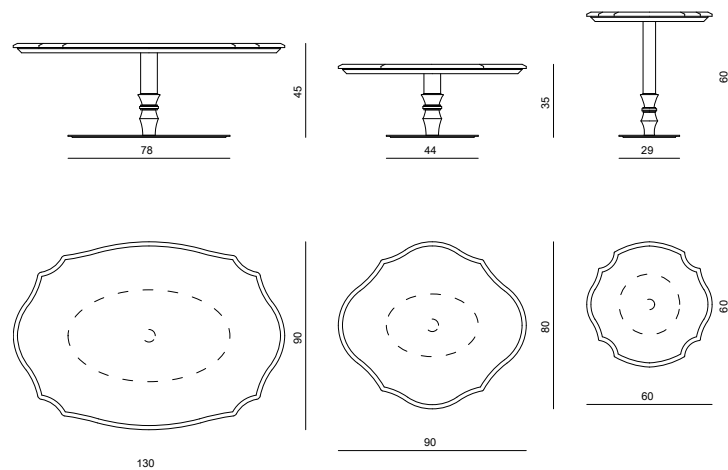

CHATAM

TAVOLO BASSO, TAVOLINO - LOW TABLE, SMALL TABLE
Alessandro La Spada

Base in acciaio inox finitura lucida con stemma araldico Visionnaire in ottone, gamba in ottone con torniture in alluminio ed elemento in cristallo a piombo soffiato e molato, con lavorazione bugnata, finitura acidata; sotto-top in acciaio inox e top in marmo bisellato. Le parti in metallo sono disponibili nella selezione finiture metalliche.

Structure in shiny stainless steel with Visionnaire coat of arms in brass, leg in brass with aluminium turnings and insert in blown and grinded crystal, with diamond pattern and with frosted finishing. Undertop in stainless steel and top in bevelled marble. Metal details can be finished with any lacquer of the metal lacquer finish selection.

vedi anche/see also CHATAM divano, poltrona-sofa, armchair, CHATAM tavolo da pranzo-dining table

● click here

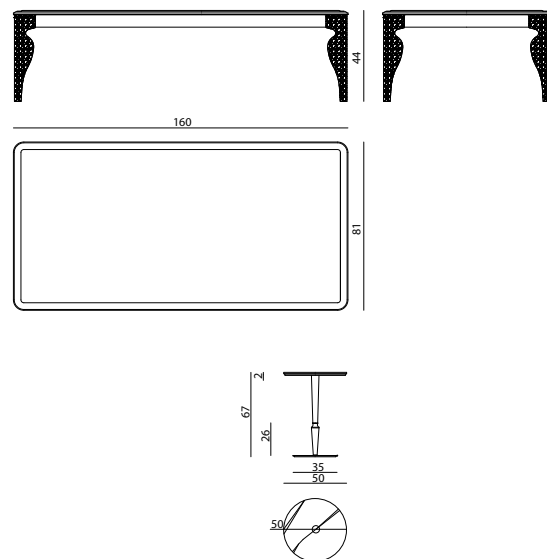

DONALD

TAVOLO BASSO - LOW TABLE
Giuseppe Viganò

Tavolino in marmo, top in lastra spessore con decorazioni incise in bassorilievo dipinte a mano. Bordo con bisellatura in negativo. Base in massello di marmo lavorato dal pieno a forma conica e decorazioni incise in bassorilievo dipinte a mano. Disponibile nelle seguenti varianti: marmo Bianco Carrara con incisione ventagli o rombi, marmo Nero Marquina con incisione ventagli o rombi.

Low table in marble, top slab with engraved and hand painted decorations in bas-relief. Negative bevelled edge. Base in solid conical shaped marble with carved in bas-relief and hand painted decorations. Available in marble Bianco Carrara with fan or rhombuses engraving, or in Nero Marquina with fan or rhombuses engraving.

● click here

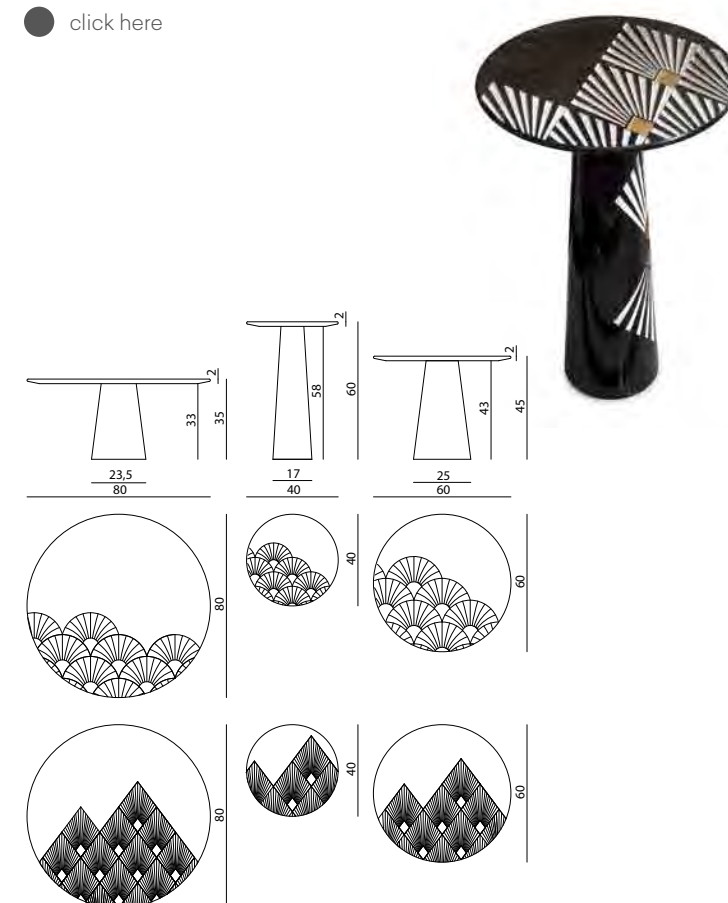

MAXIM'S

TAVOLINO - COFFEE TABLE
Alessandro La Spada

Base in acciaio inox finitura lucida con stemma araldico Visionnaire in ottone, gamba in ottone con torniture in alluminio ed elemento in cristallo a piombo soffiato e molato, con lavorazione bugnata, finitura acidata; sotto-top in acciaio inox e top in marmo bisellato. Le parti in metallo sono disponibili nella selezione finiture metalliche.

Structure in shiny stainless steel with Visionnaire coat of arms in brass, leg in brass with aluminium turnings and insert in blown and grinded crystal, with diamond pattern and with frosted finishing. Undertop in stainless steel and top in bevelled marble. Metal details can be finished with any lacquer of the metal lacquer finish selection.

● click here

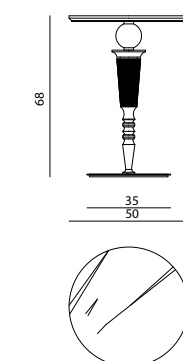



WEXFORD

TAVOLO BASSO, TAVOLINO - LOW TABLE, SMALL TABLE

Alessandro La Spada

Tavolo basso con cassetti. Top in marmo incassato in una cornice in ottone trafilato cromato. Struttura in legno laccato 100 gloss, fregi in acciaio inox lucidato a doppio spessore 3+3 mm, decorazioni delle gambe in alluminio ed acciaio laserato. Parti in metallo disponibili nella selezione finiture metalliche.

Low table with drawers. Top in marble, recessed in a chromed drawn brass frame. Structure in 100 gloss lacquered wood. Polished stainless steel decorations with double thickness 3+3mm. Aluminium and steel laser cut legs decorations. Metal parts available in any colour included in the metal finish selection.

● [click here](#)

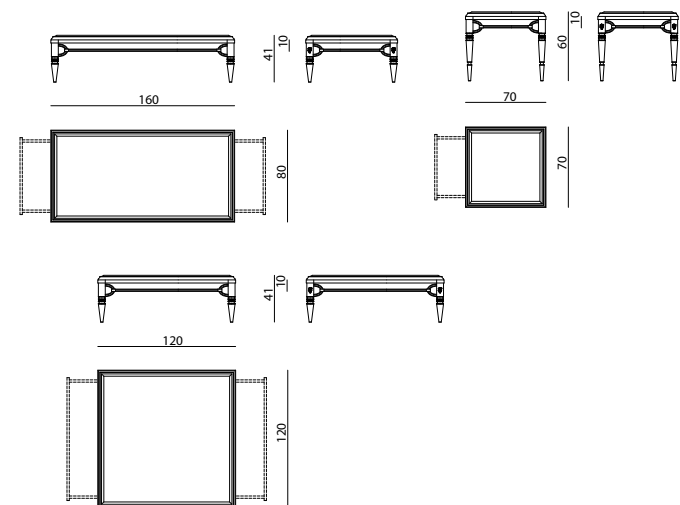

- click on the icons -



ACER p.254



ALBA p.254



AURORA p.255



AXEL p.255



AZIMUT p.256



BANNER p.256



BARBICAN p.257



BARRETT p.257



EKOS p.258



HORIZON p.258



KARNAK p.259



KEU p.259



KINGS CROSS p.260



LEGO p.260



MARTY p.261



MILTON p.261



MONDRIAN p.262



NADIR p.262



VINCENT p.263

- click on the icons -

ICONICI - *ICONIC*



ARCHINTO p.264



CHANTILLY p.264



FOUQUET p.265



GRETEL p.265



VERSAILLES p.266



ACER

CONSOLLE - CONSOLE

La Conca

Struttura in tamburato multistrati e massello di abete. Rivestimento esterno in formelle di specchio o vetro retro laccato, bisellate su 4 lati. Due cassetti con interno laccato opaco, ad apertura manuale e chiusura soft con guida autorientante. Formelle con stemma araldico Visionnaire posizionate nei due angoli.

Structure in honeycomb board plywood and fir solid wood. External cover made of mirror or lacquered glass tiles, bevelled on all 4 sides. Equipped with two drawers with mat lacquered internal parts, with manual opening and soft locking with self-returning slide. Tiles with Visionnaire logo placed in the two corners.

vedi anche/see also ACER tavolo basso-low table, ACER specchiera-mirror

● [click here](#)

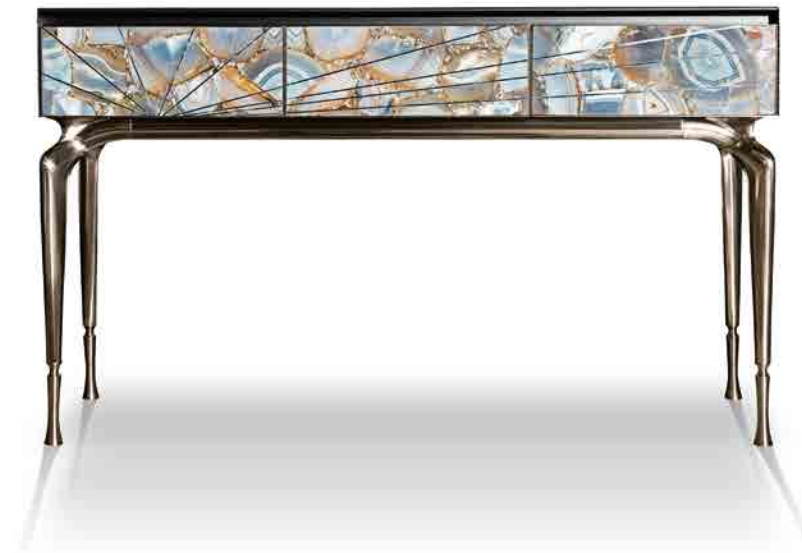
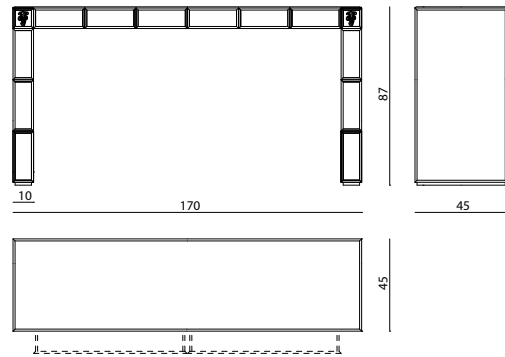

AURORA

CONSOLLE - CONSOLE

Steve Leung

Consolle con tre cassetti in legno rivestita in lamiera di acciaio inox satinato, interni e schienale laccati opaco (colori RAL). Cassetti rivestiti in marmo con intarsi e cornice in acciaio inox, gambe in fusione di alluminio lucidata a specchio con puntali in alluminio satinato. Parti in metallo disponibili in finitura oro o bronzo oppure nickel nero.

Wooden console with three drawers covered in brushed stainless steel, internal and back part in lacquered mat (RAL colours). Drawers covered in marble, framed and inlaid in stainless steel. The inlay design continues on the sides. Legs in polished aluminium cast with final tips in brushed aluminium. All metal details are available in gold, bronze or black nickel finishing.

vedi anche/see also AURORA media-high unit, AURORA mobile bar-bar cabinet, AURORA mobile trucco-vanity unit

● [click here](#)

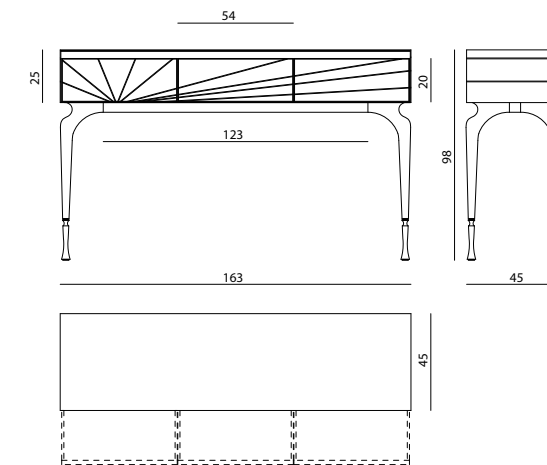

ALBA

CONSOLLE - CONSOLE

Steve Leung

Consolle con tre cassetti in legno rivestita in specchio bronzo o fumè con bordi bisellati, interni laccati nei colori RAL/NCS opachi. Cassetti rivestiti in specchio con bordi bisellati e decorazione retro-sabbiata. Gambe in fusione di alluminio lucidata a specchio con puntali in alluminio satinato.

Console with three drawers in wood covered in bronze or smoked mirror with bevelled edges. Internal parts lacquered with matt RAL/NCS colours. Drawers covered in mirror with bevelled edges and rear sand-blasted decoration. Legs in polished aluminium cast with tips in satin aluminium.

● [click here](#)

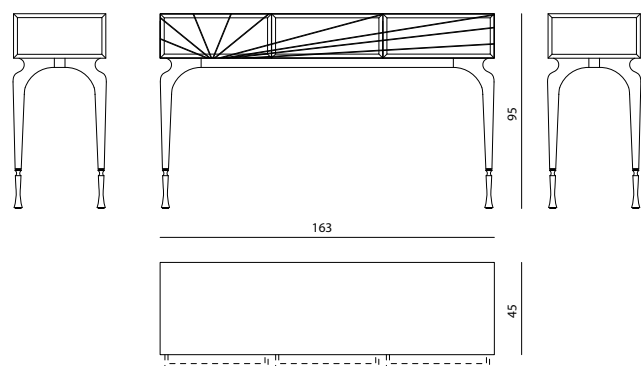
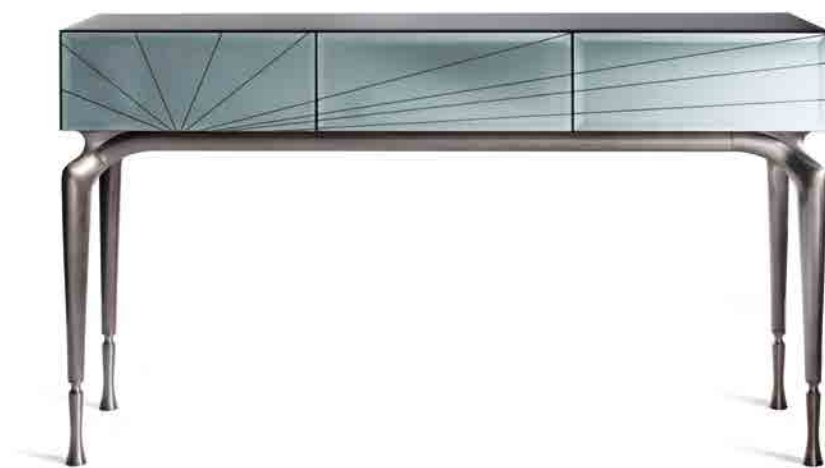

AXEL

CONSOLLE - CONSOLE

La Conca

Struttura in acciaio inox lucido con profilo del top a sezione diamantata. Top in vetro incassato retrolaccato. Top Art Gallery: Soggetto Foglie. Le parti metalliche sono disponibili nella selezione finiture metalliche.

Polished stainless steel structure with top profiles in diamond section. Recessed top in lacquered glass. Top Art Gallery: Leaves. Metal parts can be lacquered in any colour included in the metal finish selection.

vedi anche/see also ALBERO art-gallery

● [click here](#)

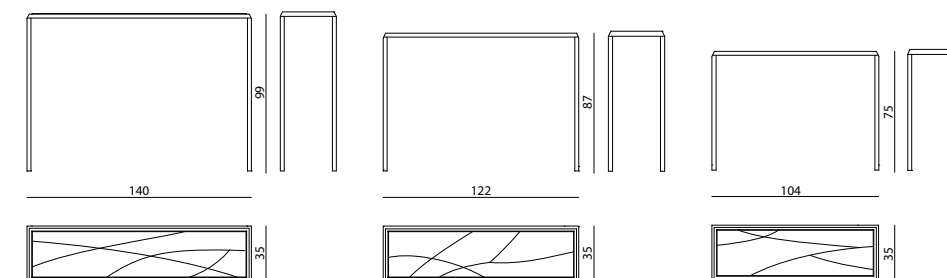

AZIMUT

CONSOLLE - CONSOLE

Steve Leung

Consolle con due cassetti, struttura in multistrati di legno rivestita in pelle o laccata, gole in acciaio inox satinato, pannelli decorativi frontali in marmo oppure in pietra naturale a spacco vivo con inserti in acciaio inox lucido. Gambe in acciaio inox satinato. Le parti in acciaio sono disponibili satinare nella selezione finiture metalliche.

Console with 2 drawers, structure in plywood covered in leather or in lacquered wood, grooves and frames in satinized stainless steel, front decorative panels in marble or in natural cleft stone with inserts in shiny stainless steel. Legs in satinized stainless steel. Metal parts available in the satinized metal finishing selection.

vedi anche/see also AZIMUT media-cabinet, AZIMUT cassetiera-chest of drawers

● click here

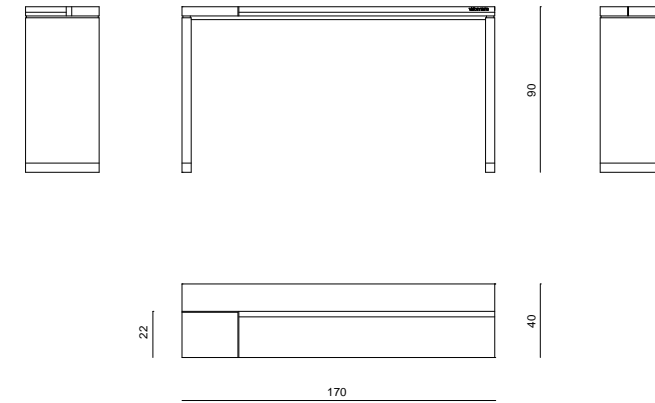
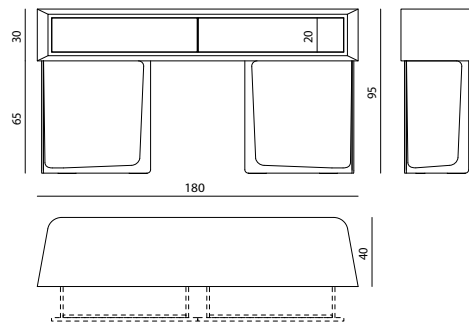

BARBICAN

CONSOLLE - CONSOLE

Alessandro La Spada

Consolle in legno rivestito in essenza oppure tinte RAL/NCS, con finitura lucida o opaca. Porzione del top in marmo, profili di finitura in acciaio lucido o satinato, disponibile nella selezione finiture metalliche.

Console in wood covered in veneer wood or RAL/NCS lacquer, with polish or mat finish. Top partially in marble, profiles in steel with polish or satin finish - available in any of the lacquer included in the metal finish selection.

vedi anche/see also BARBICAN media-low unit

● click here



BANNER

CONSOLLE - CONSOLE

Fabio Bonfà

Consolle a 2 cassetti in legno scolpito in bassorilievo con disegno a righe verticali, top in marmo con profilo lavorato in negativo. Telaio e profili decorativi in acciaio inox satinato, ripiano portariviste in cristallo fumé. I cassetti sono rivestiti internamente in microfibra. Le parti in legno sono disponibili nelle finiture opache B.180, B.181, B.182, C.001. Le parti metalliche sono disponibili nella selezione finiture metalliche satinare.

Console with 2 drawers in carved wood in low relief with vertical stripes design, marble top with negative machined profile. Frame and decorative profiles in brushed stainless steel, smoked crystal magazine rack. Drawers internally lined with microfibre. The wooden parts are available in matt finishes B.180, B.181, B.182, C.001. Metal parts available in the satinized metal finishing selection.

vedi anche/see also BANNER tavolo basso-low table

● click here

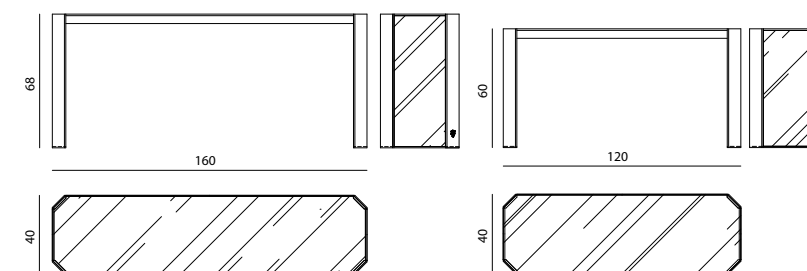
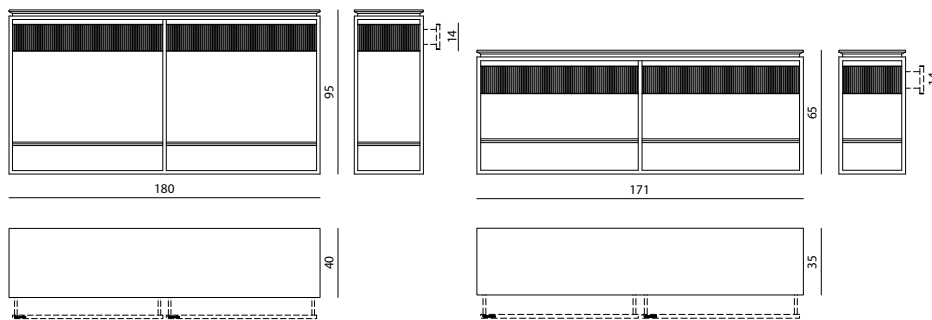

BARRETT

CONSOLLE - CONSOLE

Alessandro La Spada

Consolle in acciaio e vetro, telaio in acciaio inox satinato con quattro gambe inclinate con finitura a satinatura profonda con logo inciso. Top e fianchi in lastra di vetro fumé da 10 mm saldati a UV sagomati con spigoli sfaccettati. Il telaio è disponibile nella selezione finiture metalliche satinare.

Consoles in steel and mirror, frame in satinized stainless steel with 4 slanted legs with logo engraved. UV-welded shaped top and sides in smoked 10 mm glass with faceted corners. The frame is available in the satinized metal finishing selection.

vedi anche/see also BARRETT tavolo basso-small table

● click here



VERSIONE RADICA/ RADICA VERSION

EKOS

CONSOLLE - CONSOLE

Alessandro La Spada

Consolle in legno con top e gambe concavi rivestiti in essenza con finitura lucida 100 gloss, la parte interna è rivestita in acciaio inox lucido curvato. Top superiore in cristallo fumé. Le parti in metallo sono disponibili nella selezione finiture metalliche, le parti in legno sono disponibili nelle finiture selezione essenze lucide.

Disponibile versione EKOS RADICA con top e gambe rivestiti in radica con finitura lucida 100 gloss. Disponibile con top e gambe rivestiti in radica con finitura lucida 100 gloss.

Consolle in marmo massello con top e gambe a lavorazione concava lucidata a mano, la parte interna è rivestita in acciaio inox lucido curvato. Top superiore in cristallo fumé. Le parti in metallo sono disponibili nella selezione finiture metalliche, le parti in legno sono disponibili nelle finiture selezione essenze lucide.

Console in wood with polished veneered concave legs and top, the inside part is covered in curved polished stainless steel. Upper top in smoked crystal. Metal parts available in the polished metal finishing selection, wooden parts available in the veneer selection finishings.

Available EKOS RADICA version with top and legs covered in burr walnut with 100 gloss finish. Also available with concave top and legs in polished burr walnut.

Console in solid marble with concave work for top and legs, handmade polished. The inside part is covered in curved polished stainless steel. Upper top in smoked crystal. Metal parts available in the polished metal finishing selection, wooden parts available in the veneer selection finishings.

vedi anche/see also EKOS panca-bench [click here](#)

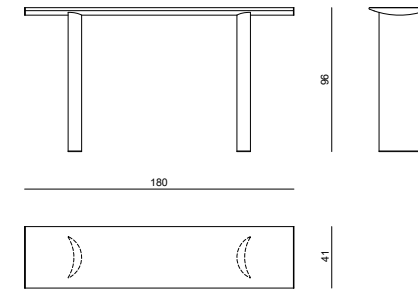
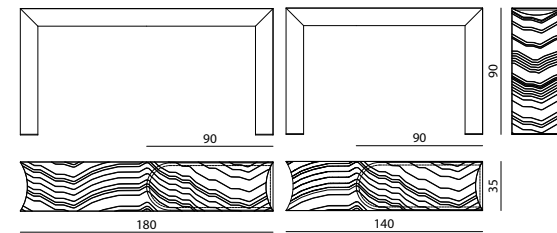

KARNAK

CONSOLLE - CONSOLE

Alessandro La Spada

Consolle in marmo, top in marmo con sotto-top in legno verniciato opaco e profili di testa in acciaio inox, gambe in acciaio scatoato con superfici concave e convesse. Parti metalliche disponibili nella selezione finiture metalliche. Attacco a parete incluso.

Console in marble, top in marble with mat painted wooden under-top and head profiles in stainless steel, legs in boxed steel with concave and convex surfaces. Metal parts available in the metal finishes selection. Wall fixing system included.

vedi anche/see also KARNAK libreria-bookshelf

[click here](#)



HORIZON

CONSOLLE - CONSOLE

Alessandro La Spada

Struttura in legno massello, gambe rivestite esternamente in pelle o in essenza, internamente in acciaio satinato. Cornice sottotop rivestita in pelle o essenza, top in marmo con profilo perimetrale in acciaio inox satinato. Le parti in legno sono disponibili nelle finiture selezione essenze. Le parti metalliche sono disponibili nella selezione finiture metalliche satinato.

Structure in solid wood, legs externally covered in leather or veneered and internally in satinized steel. Frame under top covered in leather or veneered, top in marble with perimetral profile in satinized stainless steel. Wooden parts available in the veneer selection finishings. Metal parts available in the satinized metal finishing selection.

vedi anche/see also HORIZON tavolo basso-low table, HORIZON madia-cabinet

[click here](#)

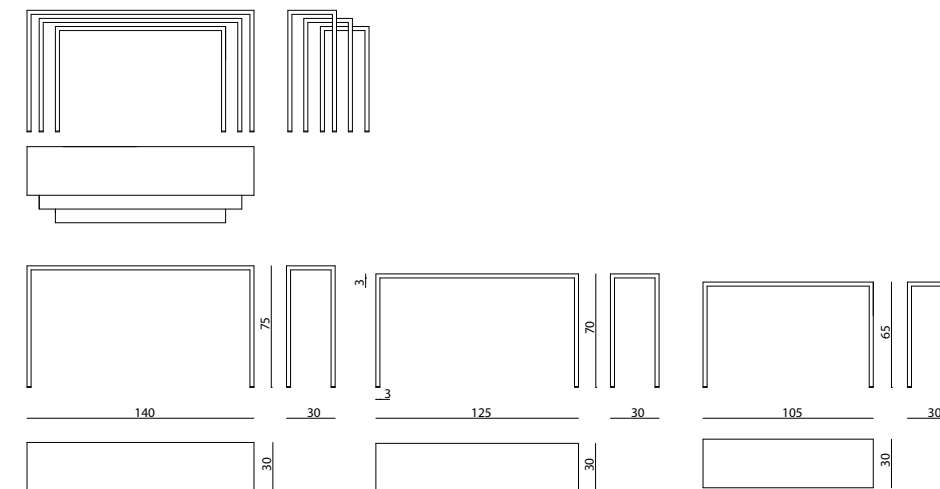

KEU

CONSOLLE - CONSOLE

Alessandro La Spada - Samuele Mazza

Struttura monoblocco in acciaio inox lucido con top satinato. Piano in lamiera spessore 2 mm, gambe in tubolare di acciaio inox. Le parti in metallo sono disponibili nella selezione finiture metalliche.

One-piece structure in polished stainless steel with satin-finish top. Top in 2 mm thick sheet metal, legs in tubular stainless steel. Metal parts are available in the metal finish selection.

[click here](#)

KINGS CROSS

CONSOLLE - CONSOLE

Mauro Lipparini

Consolle bassa, struttura portante in legno massello di noce canaletto con finitura naturale a poro aperto, scolpito con sezione sagomata a tre lobi. cabinet in legno laccato o rivestito in pelle con cestone e maniglia in metallo. Interni laccati RAL/NCS opaco. Top in marmo in appoggio disponibile con vassoio porta oggetti rivestito in pelle o tessuto. La maniglia è disponibile nella selezione finiture metalliche.

Low console. Main structure in Canaletto walnut solid wood with open-pore natural finish and shaped three-lobes section. Wooden cabinet with lacquer finish or leather upholstery, equipped with basket drawer and metal handle. Internally finished in matt RAL/NCS lacquer. Top in marble available with optional storage tray upholstered in leather or fabric. Handle available in any lacquer of the metal lacquer finish selection.

vedi anche/see also KINGS CROSS pouf-pouffe, KINGS CROSS tavolino tondo-round low table, KINGS CROSS tavolo basso-low table, KINGS CROSS mobile basso-low cabinet, KINGS CROSS cassetiera-chest of drawers, KINGS CROSS mobile trucco-vanity unit

● click here

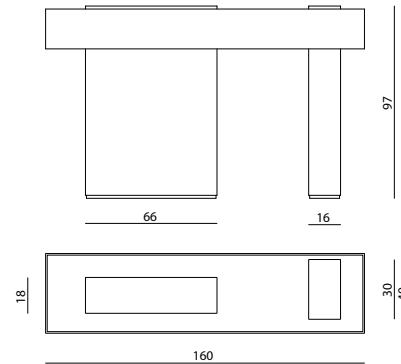
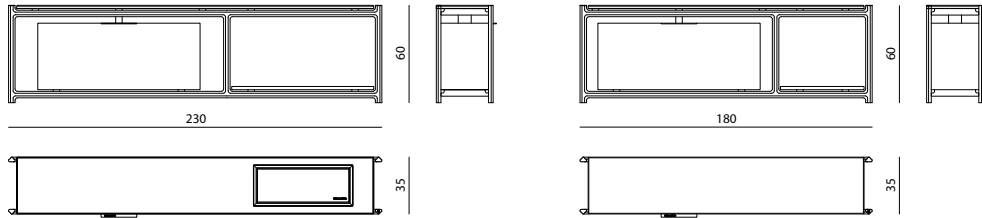

MARTY

CONSOLLE - CONSOLE

Marco Piva

Consolle in vetro composta da due basamenti rivestiti in specchio bronzo con superficie cannettato in rilievo. Top in cristallo fumé sp.8 mm scatola tramite saldatura UV. Ulteriori top di finitura in acciaio inox satinato in corrispondenza delle basi. Le parti in metallo sono disponibili nella selezione finiture metalliche satinato.

Glass console composed of two bases covered in bronze mirror with embossed surface in relief. Smoked crystal top th.8mm boxed by UV bonding. Additional finishing tops in brushed stainless steel in the bases. The metal parts are available in the metal satinized finishing selection.

Winner of the 2019 Wallpaper® Design Awards, "Dream factory" category

vedi anche/see also MARTY tavolo basso-low table

● click here



LEGO

CONSOLLE - CONSOLE

Draga&Aurel

Struttura portante in cemento e alluminio. La parte in cemento armato è lavorata con trattamento di erosione e colorazione nero opaco. Le parti in alluminio sono realizzate per fusione in sabbia con texture ondulata, lucidata e pigmentata a mano, disponibili nella selezione finiture metalliche. I due elementi possono essere montati in tre diverse configurazioni. Predisposta per attacco a parete obbligatorio.

Main structure in concrete and aluminium. The concrete part is worked with an aged surface and painted in mat black. Aluminium part is made by sand casting, textured, polished and lacquered by hand in any colour of the metal finish selection. The two elements can be mounted in three different configurations. Compulsory wall fixing.

vedi anche/see also LEGO tavolo basso-low table

● click here

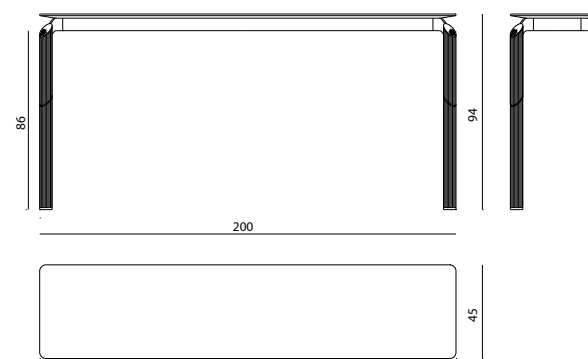
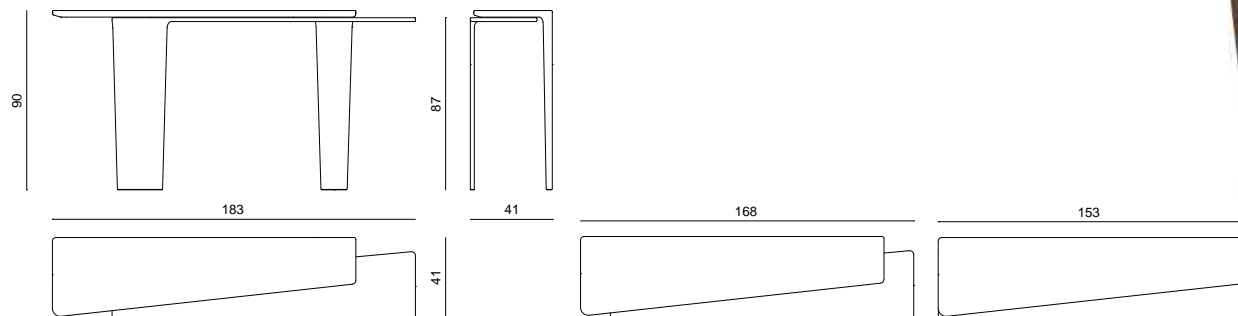

MILTON

CONSOLLE - CONSOLE

Alessandro La Spada

Struttura in acciaio e ottone satinati, con gambe cilindriche rigate a doppia finitura e logo Visionnaire inciso sulla testa a taglio obliquo. Telaio sottotop in acciaio, top in marmo con costa lavorata a smusso negativo. Le parti in acciaio sono disponibili nella selezione finiture metalliche satinato.

Structure in satinized steel and brass, with striped cylindrical legs with double finishing and Visionnaire logo engraved on the head with oblique cut. Frame undertop in steel, top in marble with "negative" manufacture on edge. Metal parts available in the satinized metal finishing selection.

● click here





MONDRIAN

CONSOLLE, CONSOLLE CON CASSETTI -
CONSOLE, CONSOLE WITH DRAWERS

Fabio Bonfà

Telaio in acciaio satinato a sezione quadrata con saldature invisibili e ripiano in cristallo extra chiaro o fumè. Top e fianco verticale in marmo tagliato in continuità di vena. Disponibile in versione alta con due cassetti in legno laccato lucido (tinte RAL/NCS). Attacco a parete. Le parti in metallo sono disponibili nella selezione finiture metalliche. Il top in marmo è disponibile anche con finitura superficiale in micro rilievo incisivo decorativo "Linfa" strutturato su marmo Rainforest, lavorazione manuale curata da Diego Crestani.

Squared frame in satin steel with invisible welded joints, shelf in extra clear or smoked crystal glass. Top and side panel in vein-cut marble. Available in high version with two drawers in polish lacquered wood (RAL/NCS colour). Wall fixing. Metal details can be finished with any lacquer of the metal lacquer finish selection. Top in marble Rainforest can be finished also with Linfa decorative micro-refined engraving, with manual processing by Diego Crestani.

vedi anche/see also MONDRIAN tavolo basso-low table

● click here

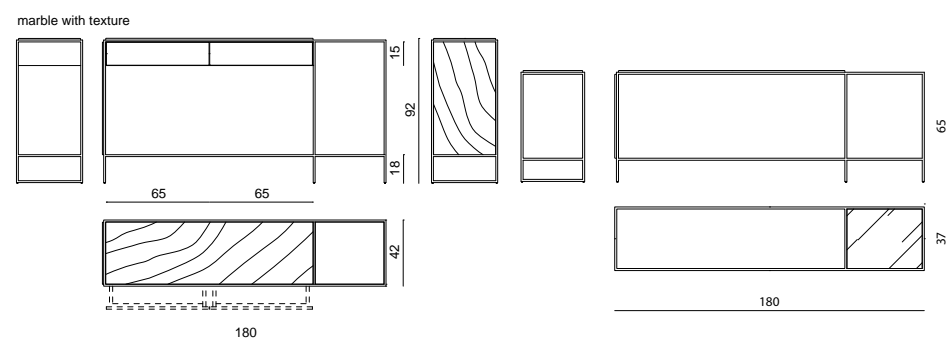

Marmi testurizzati disponibili: Colle Mandina con texture Serpente, Rain Forest con texture Linfa, Confusion Dark con texture Sea Waves, Port Laurent con texture Coccodrillo, Black&Gold con texture Galuchat.

Textured marble available: texture Snake on Colle Mandina, texture Linfa on Rain Forest, texture Sea Waves on Confusion Dark, texture Crocodile on Port Laurent, texture Galuchat on Black&Gold.



VINCENT

CONSOLLE - CONSOLE

Alessandro La Spada

Consolle con struttura in tubi metallici cromati curvati e uniti tra loro. Versione con top in vetro: lastra di vetro fumè da 12 mm con bordo bisellato, la base è collegata al top tramite supporti in alluminio e acciaio inox saldati a UV. Versione con top in marmo: lastra di marmo da 20 mm con bordo bisellato e bussole di fissaggio inferiore. Predisposta per attacco a parete tramite specifica staffa di ancoraggio sotto il top. Le parti in metallo sono disponibili nella selezione finiture metalliche, il vetro del top è disponibile nelle varianti fumè, bronzo, extra-chiaro. Il top in marmo è disponibile anche con finitura superficiale in micro rilievo incisivo decorativo "Coccodrillo" strutturato su marmo Port Laurent, lavorazione manuale curata da Diego Crestani.

Disponibile in versione VINCENT RADICA con top in radica con finitura lucida 100 gloss.

Disponibile con top in resina artistica in tre varianti colore a campionario, composto da un pannello in materiale sintetico decorato manualmente con polveri minerali rivestite in resina lucida ad alto spessore: la lavorazione comprende anche i bordi nello spessore del pannello.

Console with structure made of chrome-plated bent metal tubes joined together. Version with glass top: 12 mm smoked glass plate with bevelled edge, the base is connected to the top by means of UV-welded aluminium and stainless steel supports. Version with marble top: 20 mm marble slab with chamfered edge and lower fixing sleeves. Prepared for wall attachment by means of a specific anchoring bracket under the top. The metal parts are available in the metal finish selection, the glass top is available in smoked, bronze, extra-clear. The marble top is also available with a surface finish in "Crocodile" textured micro-relief engraving on Port Laurent marble, handcrafted by Diego Crestani.

Available in VINCENT RADICA version with top in briarwood with 100 gloss finish.

Available with top in artistic resin in three sample colours, composed of a synthetic material panel manually decorated with mineral powders coated in high gloss resin: the processing also includes the edges in the thickness of the panel.

vedi anche/see also VINCENT tavolo basso-low table

● click here

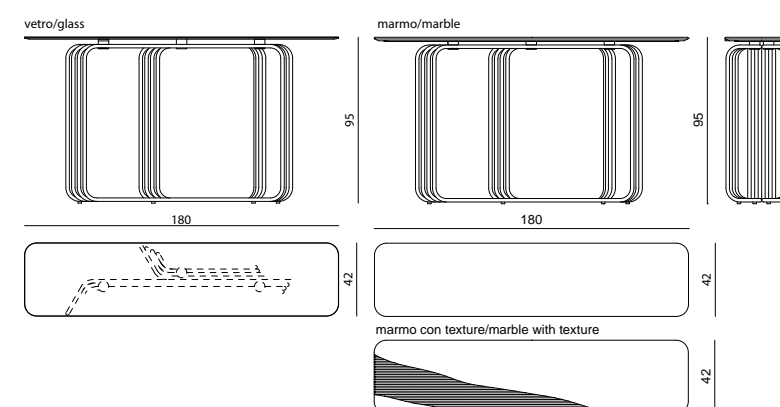

VERSIONE RADICA/ RADICA VERSION

NADIR

CONSOLLE - CONSOLE

Steve Leung

Consolle con due cassetti in legno laccato lucido nei colori RAL/NCS. Il mobile presenta una gola in acciaio inox satinato. I cassetti sono rivestiti in pelle, gli interni sono verniciati in colore nero opaco. Gambe in metallo satinato disponibili nella selezione finiture metalliche.

Console with two drawers in wood, lacquered with shiny RAL/NCS colours. Finger groove handles in satin stainless steel. Drawers upholstered in leather, internal parts with matt black lacquer finish. Metal legs can be finished with any lacquer of the satin metal lacquer finish selection.

vedi anche/see also NADIR madia-cabinet

● click here

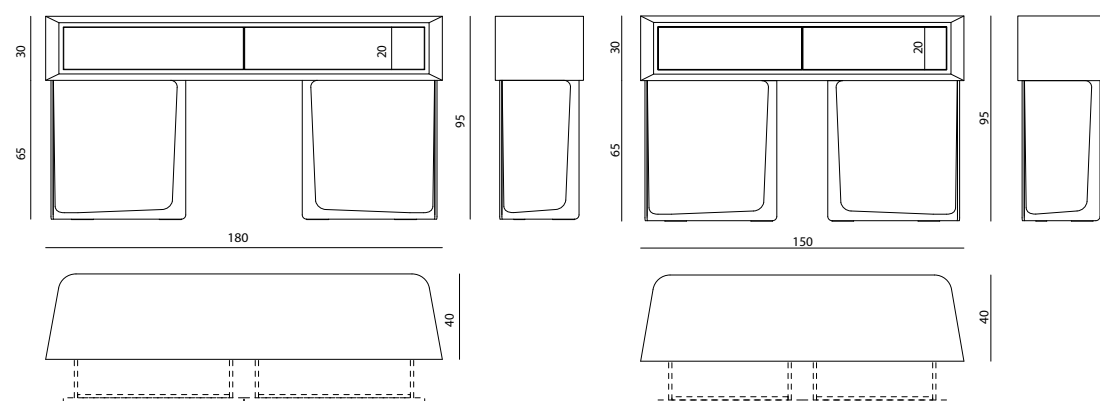



ARCHINTO

CONSOLLE - CONSOLE

Giuseppe Viganò

Struttura e top in legno laccato lucido 100 gloss (disponibile in colore nero o colori RAL scuri) con inserti decorativi in ottone naturale e madreperla sotto lacca trasparente. Gambe coniche in metallo cromato con puntale in fusione di ottone lavorata a bassorilievo, impreziosita con gemma taglio diamante in ametista viola. Cassetti con apertura pushpull. Le parti metalliche sono disponibili nella selezione finiture metalliche. Predisposta per attacco a parete.

Structure and top in polished lacquered wood in 100 gloss (available in black or dark RAL colours) with decorative inserts in natural brass and mother of pearl decorations applied on transparent varnish. Conical chromed metal legs with brass fusion studs in bas-relief, enriched with diamond shaped gems in purple amethyst. Drawers with push-pull opening. Metal parts can be lacquered in any colour included in the metal finish selection. Predisposed for wall fixing.

vedi anche/see also ARCHINTO media-cabinet

● click here

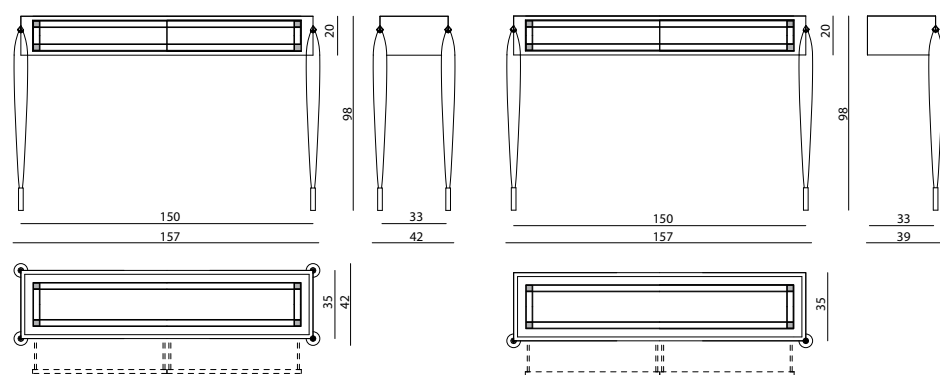

FOUQUET

CONSOLLE - CONSOLE

Maria Serebryanaya

Console con due cassetti. Struttura in MDF rivestito in vetro bisellato retrolaccato con loghi satinati. Gambe in vetro extra-chiaro temperato sp. 20 mm ricoperte da una cascata di catene decorative in alluminio cromato.

Console with two drawers. Structure in MDF covered in bevelled lacquered glass with satinized logo. Legs in extrawhite tempered glass th. 20 mm covered with a decorative cascade of chains in chromed aluminium.

vedi anche/see also FOUQUET specchiera-mirror

● click here

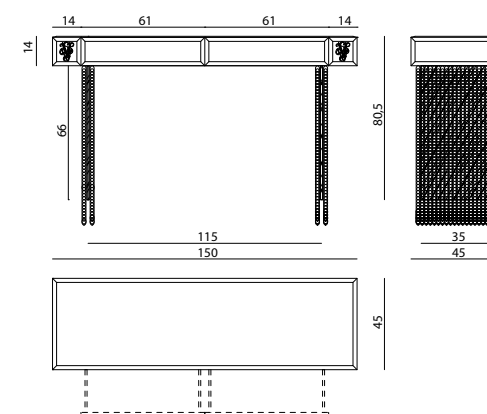

CHANTILLY

CONSOLLE - CONSOLE

Alessandro La Spada

Top in marmo sagomato e bisellato. Sottotop in MDF laccato lucido bisellato in negativo. Attacco a parete in acciaio laccato lucido. Montante in acciaio inox conico. Tornerie in alluminio. Base in fusione di alluminio goffrato. Le parti metalliche sono disponibili nella selezione finiture metalliche.

Top in bevelled and moulded marble. Top base in shiny lacquer MDF. Wall fastening in polished lacquered steel. Stem in chromed stainless steel in conic shape. Aluminium turnings. Base in polished aluminium fusion. Metal parts can be lacquered in any colour of the metal finish selection.

vedi anche/see also CHANTILLY tavoli bassi-set of 3 low tables, CHANTILLY cache-pot, CHANTILLY vaso-vase, CHANTILLY piatto-plate

● click here

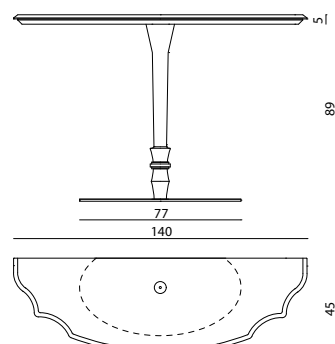

GRETEL

CONSOLLE - CONSOLE

Alessandro La Spada - Samuele Mazza

Struttura portante in compensato bilaminato in colore nero. Struttura di 6 cassetti in massello di larice con frontali in MDF. Finitura interna: laccatura goffrata colore nero. Rivestimento esterno in vetro, spessore 6 mm, bisellato su tutti i lati, disponibile nei colori di serie. Gambe in acciaio inox lucido a taglio laser, disponibili nella selezione finiture metalliche.

Main structure in double laminated plywood, black colour. Structure of 6 drawers in solid larchwood with MDF fronts. Internal finish: black embossed lacquer. External glass covering, thickness 6 mm, bevelled on all sides, available in the colours included in the Visionnaire collection. Legs in laser-cut polished stainless steel legs, available in any colour included in the metal finish selection.

● click here

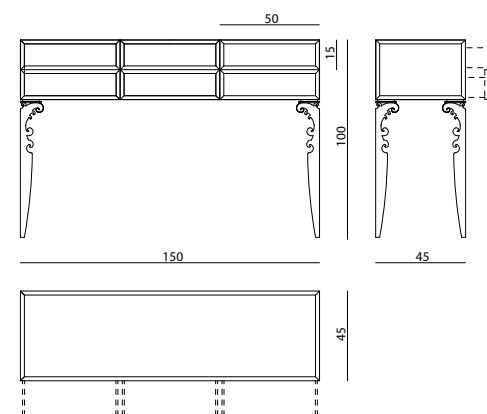



VERSAILLES

CONSOLLE - CONSOLE

Alessandro La Spada

Consolle a tre cassetti, struttura in MDF con finitura laccata lucida. Predisposizione per attacco a muro. Cassetti frontali in legno laccato curvato e finitura interna laccata opaca. Gambe con puntali e tornerie in alluminio. Inserti in cristallo tronco di cono sfaccettato. Maniglie a scudo in cuoio con stemma Visionnaire. Le parti metalliche sono disponibili nella selezione finiture metalliche.

Three drawers console, structure in MDF, shiny lacquer finishing. Arrangement for wall fixing. Front drawers in curved lacquered wood and internal finishing opaque lacquer. Legs with tips and turnings in aluminium. Inserts in conic prismatic crystal. Shield handles in simple leather with Visionnaire coats of arms. Metal parts can be lacquered in any colour included in the metal finish selection.

vedi anche/see also VERSAILLES tavolo da pranzo-dining table, VERSAILLES mobile bar-bar cabinet, VERSAILLES scrivania-desk, VERSAILLES cassettiera-chest of drawers

[● click here](#)

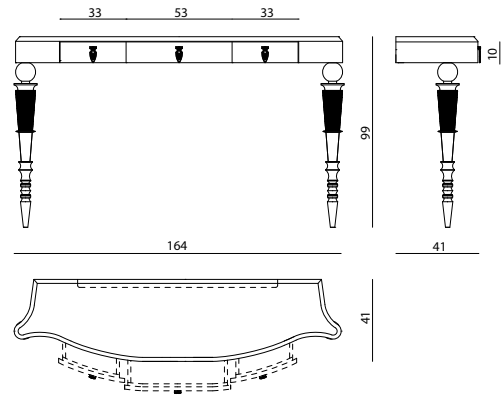

- click on the icons -



AURORA p.270



AZIMUT p.271



BARBICAN p.272



BARNEY p.273



BRONSON p.274



BRUNSWICK p.275



DANNY p.275



DESMOND p.276



DONEGAL p.277



DORINDA p.278



GARETH p.279



HAMILTON p.280



HAMILTON p.280



HORIZON p.281



KINGS CROSS p.282



LEONARDO p.283



LEONARDO p.283



LISBET p.284

- click on the icons -



LISBET p.285



MAJESTIC p.286



MAREK p.287



MIDNIGHT p.287



NADIR p.288



NOMOS p.289



PALAWAN p.289



PANAY p.290



PARKER p.291



RAWDON p.292



RUSKIN p.292



WOODY p.293

ICONICI - *ICONIC*



ARCHINTO p.294



AURORA

MADIA - HIGH UNIT

Steve Leung

Mobile in legno rivestito in lamiera di acciaio inox satinato, interni e schienale laccati opaco (colori RAL/NCS). Ante rivestite in marmo o in essenza con intarsi e cornice in acciaio inox, il disegno dell'intarsio continua attraverso i fianchi. Basamento in acciaio inox sagomato finitura cromo. Ripiani interni in legno. Le parti in legno sono disponibili nelle finiture selezione essenze; le parti metalliche sono disponibili nella selezione finiture metalliche.

I frontali in marmo della madia sono disponibili anche con finitura superficiale in micro rilievo incisivo decorativo "Sea Waves" su marmo Confusion Dark, con lavorazione manuale curata da Diego Crestani.

Wooden unit coated in brushed stainless steel; internal and back part matt lacquered (RAL/NCS colours); doors covered in marble or veneer wood with inlays and frame in stainless steel. The pattern of the inlays extends on the sides. The base is in shaped stainless steel with chromed finishings. Internal shelves in wood. Wooden parts are available with veneer selection finishings; metal parts can be lacquered in any colour included in the metal finish selection.

The marble fronts of the sideboard are also available with a micro-relief decorative "Sea Waves" finish on Confusion Dark marble, with manual processing by Diego Crestani.

vedi anche/see also AURORA consolle-console, AURORA mobile bar-bar unit, AURORA mobile trucco-vanity unit



● click here

Marmi testurizzati disponibili: Colle Mandina con texture Serpente, Rain Forest con texture Linfa, Confusion Dark con texture Sea Waves, Port Laurent con texture Coccodrillo, Black&Gold con texture Galuchat.

Textured marble available: texture Snake on Colle Mandina, texture Linfa on Rain Forest, texture Sea Waves on Confusion Dark, texture Crocodile on Port Laurent, texture Galuchat on Black&Gold.

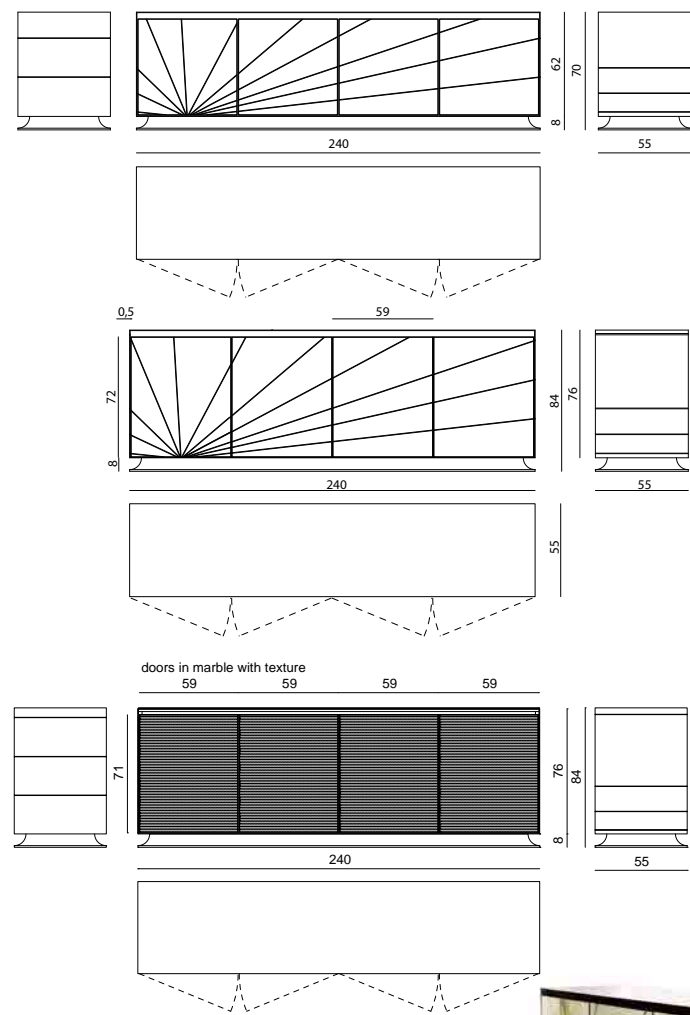

AZIMUT

MADIA - HIGH UNIT

Steve Leung

Struttura in multistrati di legno a quattro ante, due cassetti interni, rivestita in pelle o laccata, gole e cornici delle ante in acciaio inox satinato, pannelli decorativi frontali in pietra naturale a spacco vivo con inserti in acciaio inox lucido. Gambe in acciaio inox satinato. Le parti in acciaio sono disponibili satinate nella selezione finiture metalliche. Disponibile in versione bassa senza cassetti interni.

Structure in plywood with 4 doors and 2 internal drawers, covered in leather or in lacquered wood, doors grooves and frames in satinized stainless steel, front decorative panels in natural cleft stone with inserts in shiny stainless steel. Legs in satinized stainless steel. Metal parts available in the satinized metal finishing selection. Also available low cabinet with 4 doors without internal drawers.

vedi anche/see also AZIMUT consolle-console, AZIMUT cassettiera-chest of drawers

● click here

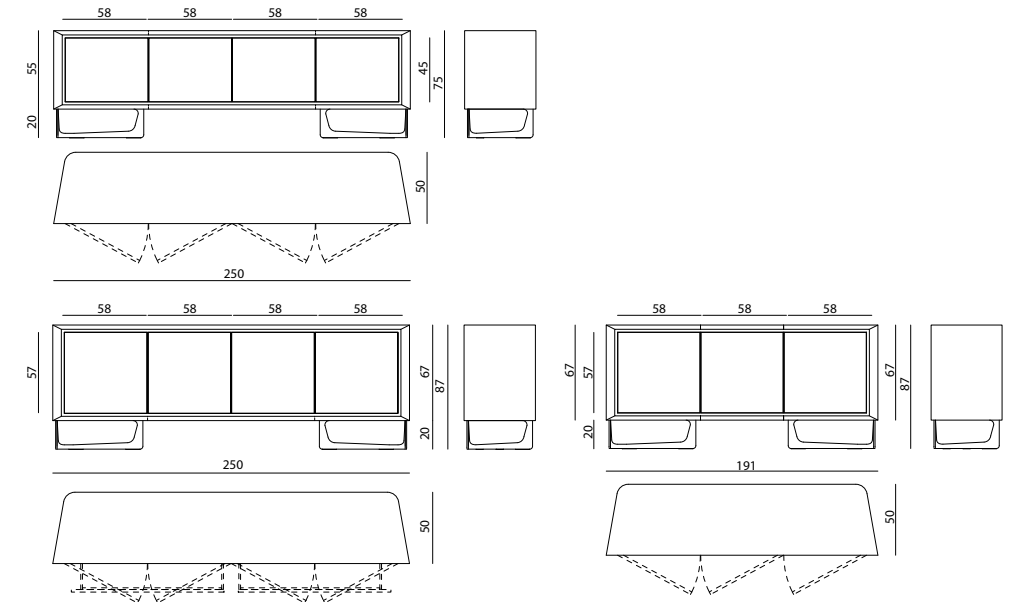



BARBICAN

MADIA - LOW UNIT

Alessandro La Spada

Mobile basso in legno rivestito in essenza oppure tinte RAL/NCS, con finitura lucida o opaca. Le tre ante hanno una superficie scolpita "cannette", disponibili in essenza opaca o tinta RAL/NCS. Porzione del top in marmo, profili di finitura in acciaio lucido o satinato, disponibile nella selezione finiture metalliche. Le parti in essenza sono disponibili nelle finiture selezione essenze.

Low unit in wood covered in wood veneer or RAL/NCS lacquer, with polish or mat finish. Three doors carved in canneté motif, available with mat veneer or Ral/NCS lacquered finish. Top partially in marble, profiles in steel with polish or satin finish - available in any of the lacquer included in the metal finish selection.

vedi anche/see also BARBICAN consolle-console

● click here

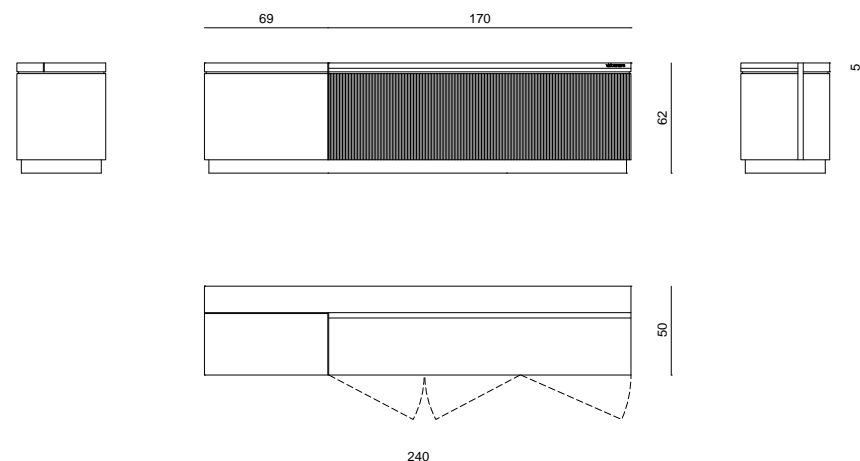

BARNEY

MOBILE BASSO - LOW UNIT

Fabio Bonfà

Mobile basso con 4 ante ed 1 cassetto, struttura in mdf rivestita in essenza con inserti in acciaio inox satinato incastonati nel legno, grande maniglione e base in acciaio inox satinato, ante in marmo a pieno spessore. Interno laccato opaco, schienale laccato opaco, in opzione disponibile in essenza. Le parti in essenza sono disponibili nelle finiture selezione essenze. Le parti in acciaio sono disponibili nella selezione finiture metalliche satinato.

Opzione: texture "Serpente" su marmo Colle Mandina sulle due porte centrali, con lavorazione manuale curata da Diego Crestani.

Low cabinet with 4 doors and 1 drawer, structure in MDF covered in veneer with inserts in satinized stainless steel embedded in the wood, big drawer handle and base in satinized stainless steel, doors in marble in full thickness, mat lacquered internal parts, mat lacquered backrest, available in veneer wood. Veneered parts available in the veneer selection finishings. Metal parts available in the satinized metal finishing selection.

Option: texture "Snake" on Colle Mandina marble on two central doors, with manual processing by Diego Crestani.

vedi anche/see also BARNEY cassettiera-chest of drawers

● click here



Marmi testurizzati disponibili: Colle Mandina con texture Serpente, Rain Forest con texture Linfa, Confusion Dark con texture Sea Waves, Port Laurent con texture Coccodrillo, Black&Gold con texture Galuchat.

Textured marble available: texture Snake on Colle Mandina, texture Linfa on Rain Forest, texture Sea Waves on Confusion Dark, texture Crocodile on Port Laurent, texture Galuchat on Black&Gold.

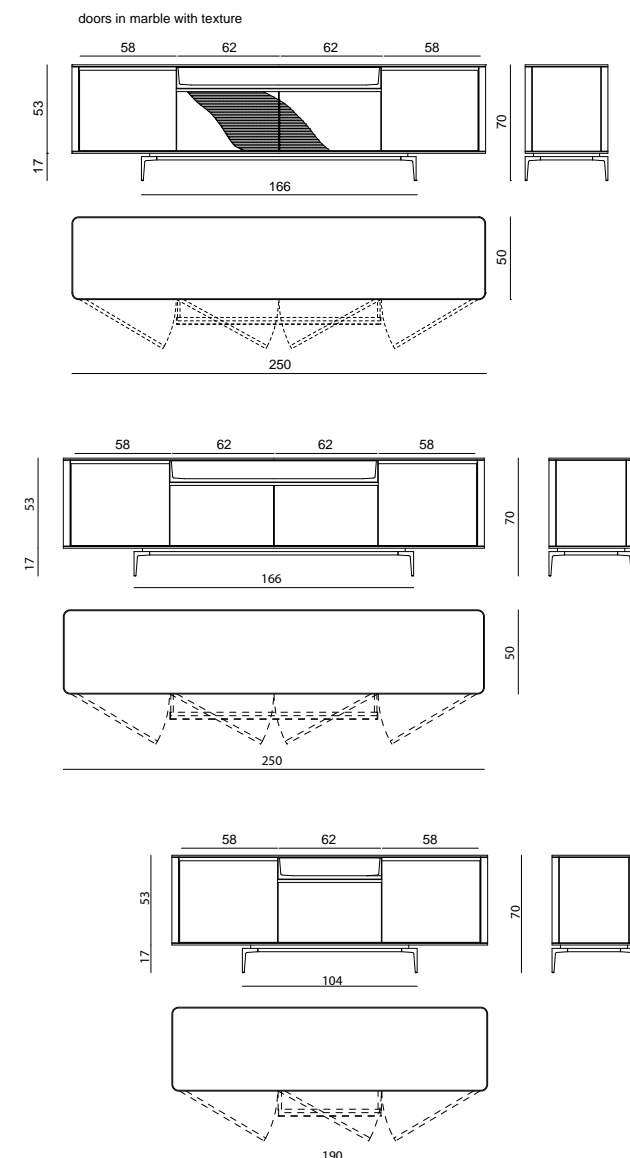



BRONSON

MOBILE BASSO - LOW CABINET

Giuseppe Viganò

Mobile basso in legno rivestito in essenza con fianchi sagomati e top centrale in marmo. Quattro ante in essenza e un cassetto con frontale in marmo con bordi accoppiati a 45°, maniglie in acciaio satinato. Interno in legno laccato 100 gloss e ripiani in cristallo extrachiaro sp.8 mm. Il cassetto è rivestito internamente in microfibra. Base in acciaio inox satinato. Le parti in legno sono disponibili nelle finiture selezione essenze, le parti metalliche sono disponibili nella selezione finiture metalliche.

Low cabinet in veneered wood with shaped sides and marble top. Four doors in wood and a drawer with marble front with edges coupled to 45°, handles in satin finish 100 gloss lacquered wood interior and extra-clear glass shelves th.8mm. Drawer internally lined in microfibre. Base in satinized stainless steel. Wooden parts available in the veneer finishings selection, metal parts available in the metal finishing selection.

● click here

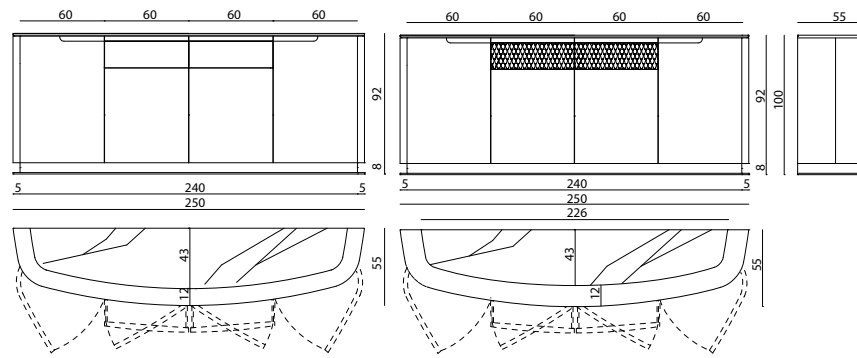
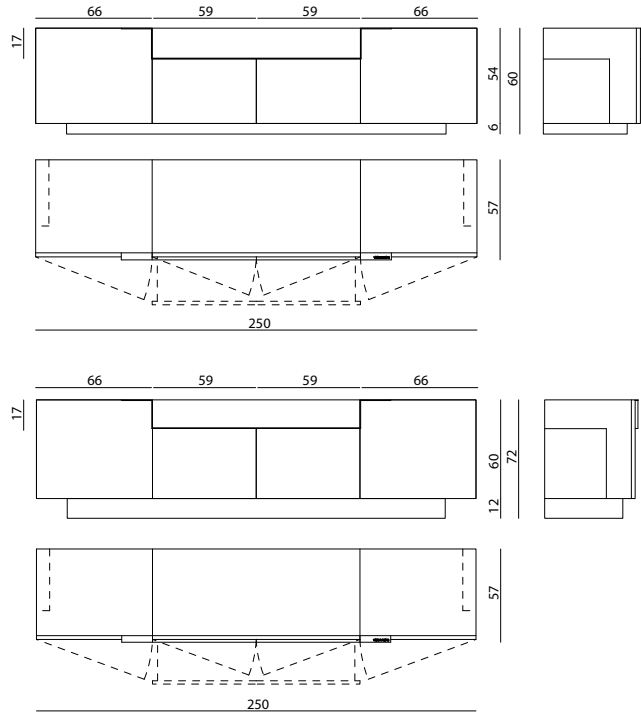

BRUNSWICK

MADIA - HIGH UNIT

Alessandro La Spada

Struttura in MDF curvo laccato lucido. Top in marmo con bordo in MDF laccato lucido. Interno cassetti e ante laccato opaco, frontali cassetti disponibili in: marmo curvo liscio, marmo curvo lavorato in basso rilievo, o in MDF curvo laccato lucido. Base in acciaio inox lucido. Ribasso apriante in acciaio inox lucido. Struttura in MDF curvo laccato lucido 100 gloss con quattro ante e quattro cassetti, 2 a vista e due interni alle ante laterali. Ribasso apri-ante e base in acciaio inox. Top in marmo con cornice perimetrale in legno laccato lucido. Le parti metalliche sono disponibili nella selezione finiture metalliche.

Structure in curved MDF shiny lacquer. Top in marble with shiny lacquered MDF border. Interior lacquered opaque, front drawers cover options: curved smooth marble, low relief decoration marble, or shiny lacquered MDF. Base in polished stainless steel. Recess for door opening in polished stainless steel. Structure in glossy 100 lacquered curved MDF with 4 doors and 4 drawers, 2 visible and 2 hidden inside the sides shutters. Horizontal stainless steel grooving "open-door". Base in stainless steel. Top in marble with shiny lacquered wood perimetral frame. Metal parts available in the metal finishing selection.

● click here



DANNY

MOBILE BASSO - LOW CABINET

Mauro Lipparini

Mobile basso a quattro ante, scocca del mobile in legno con lato esterno laccato lucido e superficie interna rivestita in acciaio satinato. Top e ante rivestite in essenza laccata al poliestere lucido, profili top in metallo satinato. Le parti in acciaio sono disponibili nella selezione finiture metalliche. Top e ante sono disponibili nelle finiture selezione essenze.

Low cabinet with four doors, main structure in wood with external side coated in satinized steel. Top and doors in veneered wood in glossy lacquered finishing, top profiles in satinized metal. Metal parts available in the metal finishing selection. Top and doors available in veneer selection finishings.

vedi anche/see also DANNY cassetiera-chest of drawers, DANNY mobile trucco-vanity unit

● click here

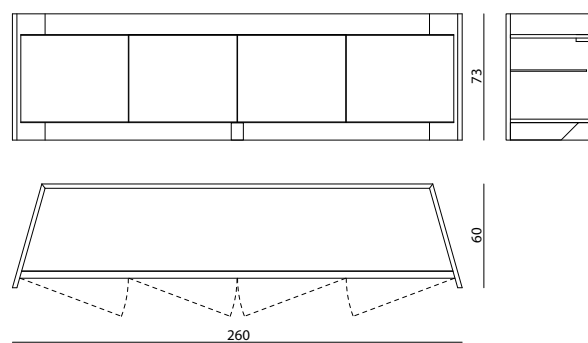



DESMOND

MOBILE BASSO - LOW UNIT

Mauro Lipparini

Mobile da centro stanza con cabinet centrale in legno e due vetrinette laterali. Cabinet con quattro ante curve ad apertura bifacciale, rivestito in essenza o laccato lucido (tinte RAL/NCS) con interno laccato a contrasto. Ripiano interno in cristallo. Le vetrine laterali sono composte da struttura in acciaio lucido con top e ante in vetro extra-chiaro e base in legno; ante (curve e piane) ad apertura bifacciale. Le vetrine sono dotate di sistema di illuminazione a LED. Le parti in legno sono disponibili nella selezione essenze o nelle tinte RAL/NCS, le parti in metallo sono disponibili nella selezione finiture metalliche lucide.

Disponibile nella versione DESMOND RADICA con cabinet centrale in radica con finitura lucida 100 gloss.

Room-central unit with central cabinet in wood and two lateral showcases. Cabinet with four curved doors with double-sided opening, finished in veneered or polish lacquered wood (RAL/NCS colours). Internally lacquered in contrasting colours. Internal shelf in crystal glass. Lateral showcases composed by a main structure in polished stainless steel with top and doors in extra clear glass and wooden base. Doors (curved and flat) open on both sides. Showcases are equipped with LED lights. Parts in wood can be finished with any veneer included in the veneer selection or RAL/NCS colours, metal parts can be lacquered in any colour included in the polish metal finish selection

Available in the DESMOND RADICA version with central cabinet in burr walnut with 100 gloss finish.

● click here



VERSIONE RADICA/ RADICA VERSION

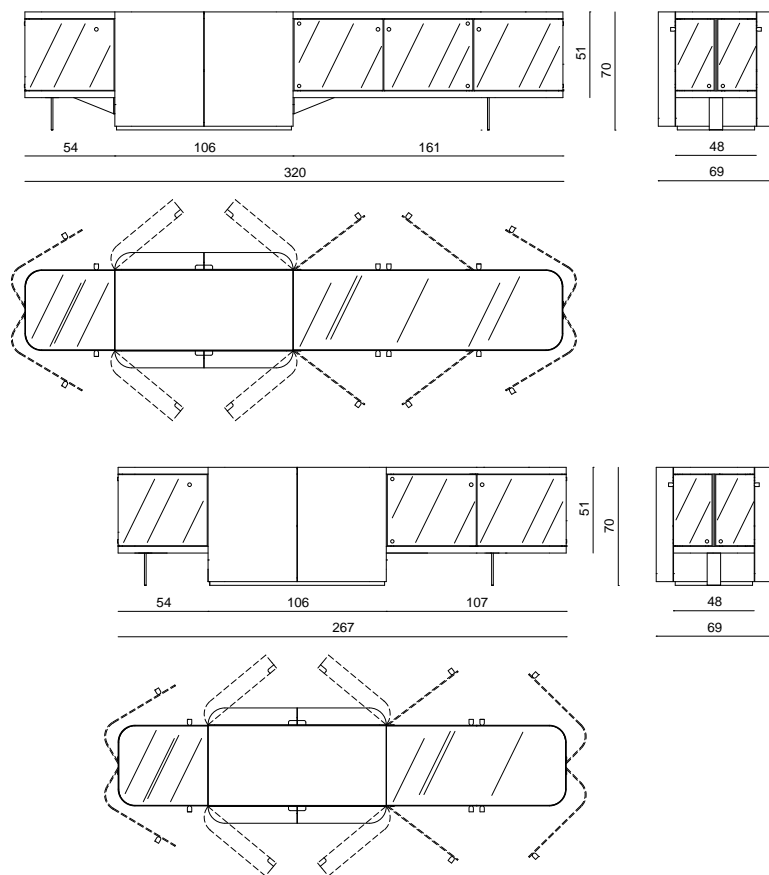

DONEGAL

MADIA - HIGH UNIT

Mauro Lipparini

Mobile alto a quattro ante e quattro cassetti in legno laccato lucido (tinte RAL/NCS) con estremità bombate. Interno in legno in tinta, ripiani in vetro extra-chiaro, disponibile con illuminazione a LED (opzionale). Fregi decorativi e piedi in metallo, disponibili nella selezione finiture metalliche lucide.

High unit with four doors and four drawers in polish lacquered wood (RAL/NCS colours) with convex sides. Internally lacquered tone on tone, shelves in extra clear glass, optional internal LED light available. Decorative friezes and feet in metal can be lacquered in any colour included in the metal polish finish selection.

● click here

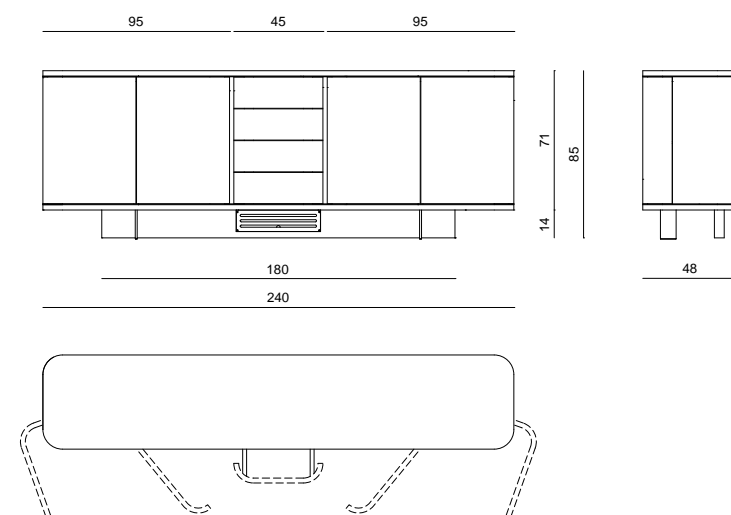



DORINDA GLASS

MOBILE BASSO - LOW UNIT

Mauro Lipparini

Mobile basso a quattro ante in vetro curvo bronzo o fumé. Base e top in legno rivestito in essenza o laccato (tinte RAL/NCS), disponibile con illuminazione a LED (opzionale). Vano centrale con ripiano in metallo e dotato di foro passacavi. Fregi decorativi e gambe in metallo disponibili nella selezione finiture metalliche lucide. Base dei vani in vetro protette da pad in microfibra.

Low unit with four doors in curved bronze or smoked glass. Base and top in wood with veneered or lacquered finish (RAL/NCS colours). Visible internal structure, which can be equipped with LED lights (optional). Central compartment with metal shelf and cable hole. Decorative friezes and legs in metal can be lacquered in any colour of the polish metal finish selection. Base of glass compartments covered with a pad in microfiber.

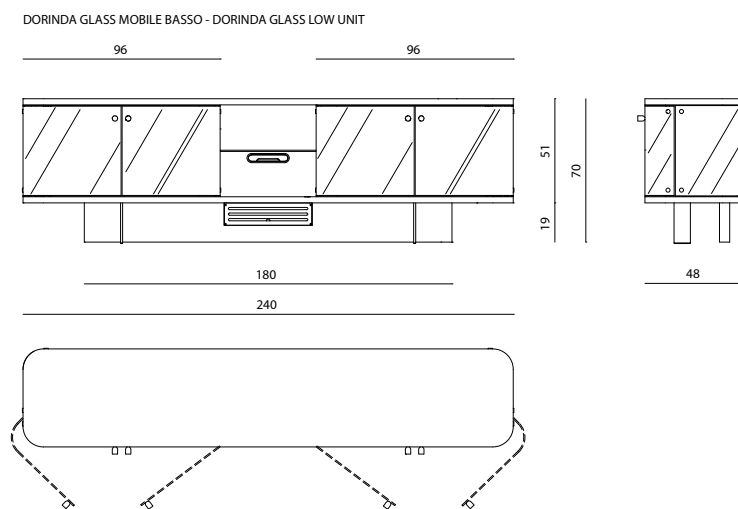

DORINDA WOOD

MOBILE BASSO - LOW UNIT

Mauro Lipparini

Mobile basso a quattro ante in legno curvo. Base e top in legno laccato (tinte RAL/NCS), disponibile con illuminazione a LED (opzionale). Vano centrale con ripiano in metallo e dotato di foro passacavi. Fregi metallici decorativi e gambe in alluminio. Le parti in metallo sono disponibili nella selezione finiture metalliche lucide.

Low unit with four doors in curved wood. Base and top in lacquered wood (RAL/NC colours), optional internal LED light available. Central compartment with metal shelf and cable hole. Metal decorative friezes and legs in aluminium. Metal parts can be lacquered in any colour of the polish metal finish selection.

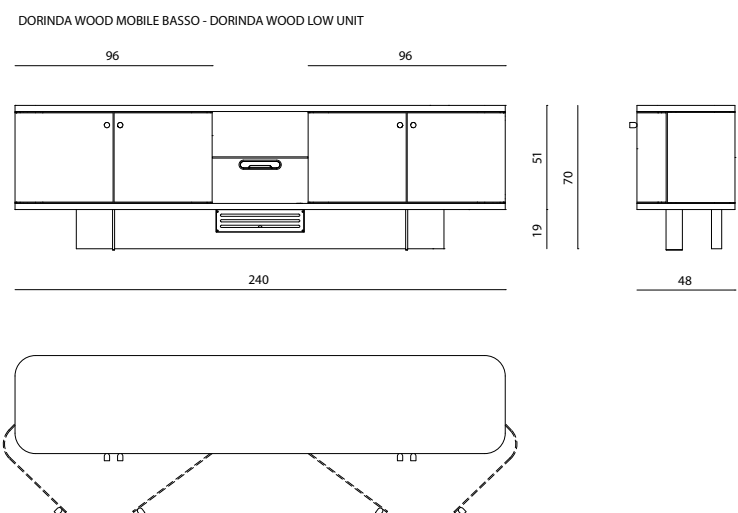

click here



GARETH

MOBILE BASSO - LOW UNIT

Alessandro La Spada - Samuele Mazza

Struttura portante in legno. Rivestimento esterno in lamiera d'acciaio inox lucido. Top in vetro retrolaccato nei colori di serie. Pareti interne laccate nel colore nero opaco. Ripiani interni in vetro. Sulla parete di fondo sono previsti fori ed asole per il passaggio dei cavi per impianto HI-FI e TV. Il mobile può essere fornito, a richiesta del cliente, con ante tutte in acciaio inox oppure in vetro fumé con bordo in acciaio inox. Zoccolo di base ligneo in finitura laccato nero lucido.

Main frame in wood. External cover in polished stainless steel plate. Top in retrolacquered glass in standard colours. Internal walls lacquered matt black. Internal shelves in glass. The rear panel has holes and openings for the passing of cables for HI-FI systems and TV. The unit may be supplied, on request with doors totally in stainless steel or in glass fumé with border in stainless steel. Wooden baseboard in glossy black lacquered finish.

click here

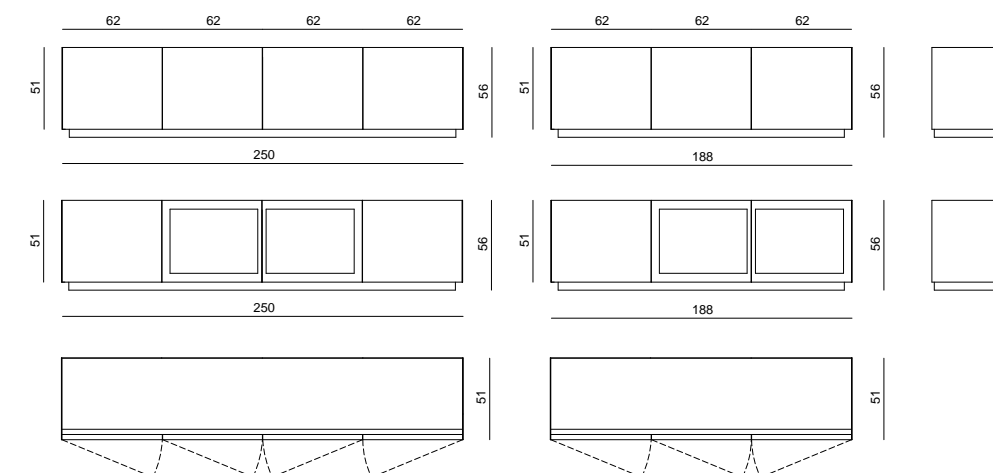

HAMILTON

MADIA - CABINET

Alessandro La Spada

Madia alta a quattro ante e tre cassetti, struttura in legno con fianchi concavi in essenza e finitura manuale lucida 100 gloss oppure laccata lucida. La cornice interna dei fianchi e del top è rivestita in acciaio inox lucido curvato. Interno laccato RAL/NCS opaco. Le parti in metallo sono disponibili nella selezione finiture metalliche, le parti in legno sono disponibili nelle finiture selezione essenze oppure verniciate in colori RAL/NCS.

High unit with four doors and three drawers, structure in wood with concave side in veneered wood finished with 100 gloss polish applied by hand or with shiny lacquer. Sides and top internal frame covered in curved stainless steel with shiny finish. Internally finished with matt RAL/NCS lacquer. Metal parts can be finished with any lacquer of the metal lacquer finish selection. Wooden parts can be finished with any wood veneer of the veneer finish selection or with RAL/NCS lacquer.

vedi anche/see also HAMILTON cassetiera-chest of drawers

● click here

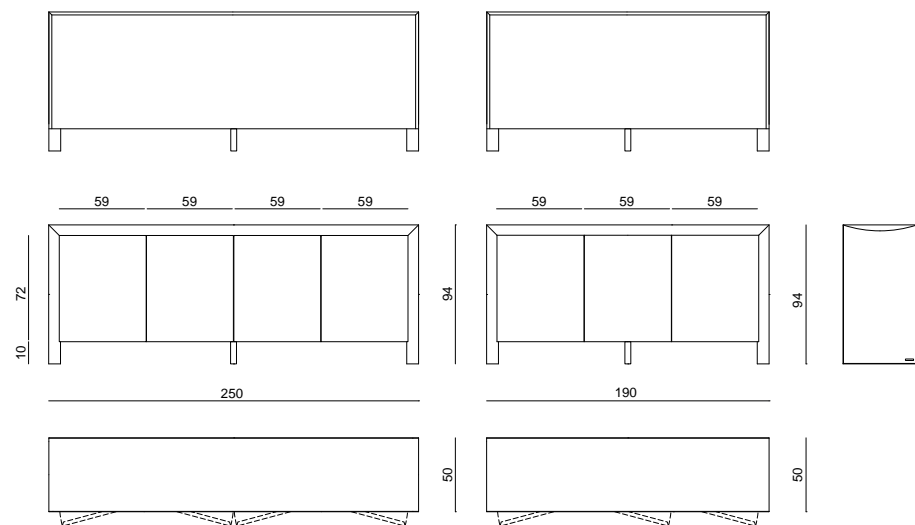

HAMILTON

MOBILE BASSO - LOW UNIT

Alessandro La Spada

Mobile basso a quattro ante, struttura in legno con fianchi concavi in essenza e finitura manuale lucida 100 gloss oppure laccata lucida. La cornice interna dei fianchi e del top è rivestita in acciaio inox lucido curvato. Interno laccato RAL/NCS opaco. Le parti in metallo sono disponibili nella selezione finiture metalliche, le parti in legno sono disponibili nelle finiture selezione essenze oppure verniciate in colori RAL/NCS.

Low unit with four doors, structure in wood with concave sides in wood with hand-made 100 gloss veneered finish or polish lacquer finish. Internal frame of top and sides covered in curved stainless steel. Internally lacquered in RAL/NCS colours with matt finish. Metal parts can be lacquered in any colour of the metal finish selection; wood parts can be finished with any veneer of the veneer selection or with RAL/NCS colour lacquering.

vedi anche/see also HAMILTON cassetiera-chest of drawers

● click here

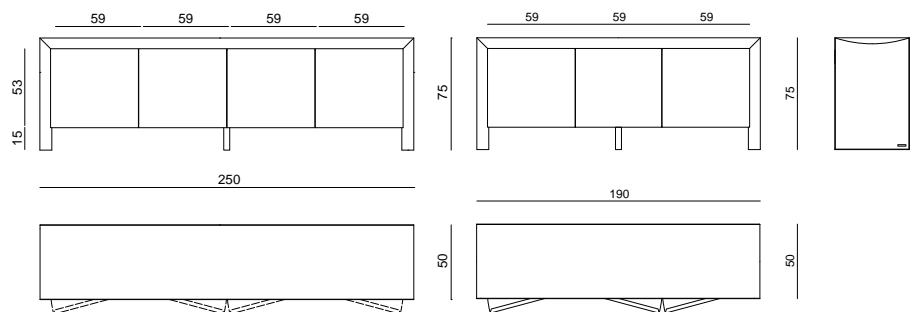

HORIZON

MADIA - CABINET

Alessandro La Spada

Struttura in multistrati e MDF, top superiore, vano a giorno ed interni laccati lucidi, struttura esterna e frontali in essenza intarsiata con inserti in acciaio inox. Struttura di base con piedi in acciaio inox satinato. Top inferiore e fianchi interni in marmo. Le parti in acciaio sono disponibili nella selezione finiture metalliche satinato. Le parti in legno sono disponibili nelle finiture selezione essenze.

Structure in plywood and MDF, upper top, open niche and internal parts in glossy lacquered finishing, external structure and front parts in veneer with inserts in stainless steel. Base structure with feet in satinized stainless steel. Lower top and internal sides in marble. Metal parts available in the satinized metal finishing selection. Veneered parts available in the veneer selection finishings.

vedi anche/see also HORIZON tavolo basso-low table, HORIZON consolle-console

● click here

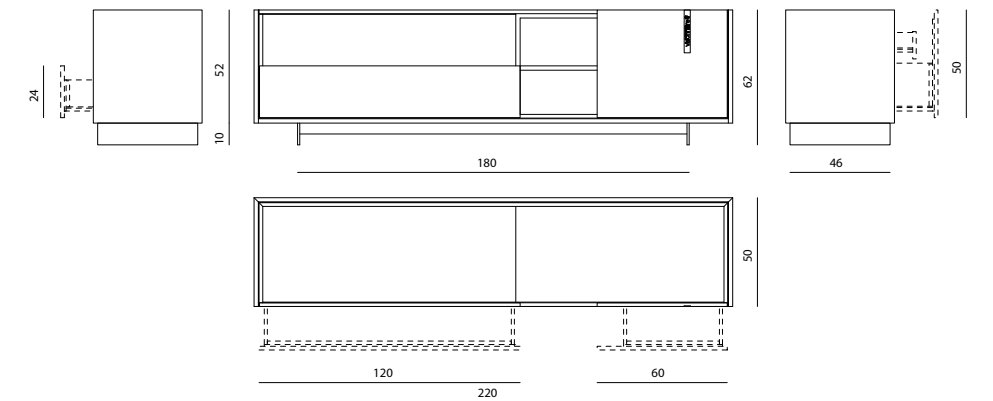

KINGS CROSS

MOBILE BASSO - LOW CABINET

Mauro Lipparini

Mobile basso con ante e fianchi curvi. Struttura esterna portante in legno massello di noce canaletto con finitura naturale a poro aperto, scolpito con sezione sagomata a tre lobi, struttura interna in legno composta da ante e fianchi curvati, disponibili in finitura verniciata RAL/NCS lucido o rivestiti in pelle. Maniglie in metallo satinato. Interni laccati RAL/NCS opaco. Top in marmo incassato. Disponibile con illuminazione interna a LED. Le maniglie sono disponibili nella selezione finiture metalliche.

Low cabinet with doors and curved sides. Supporting frame in Canaletto walnut solid wood with open-pore natural finish and shaped three-lobes section; wooden structure with doors and curved sides, available with shiny RAL/NCS lacquer finish or with leather upholstery. Handles in satin metal. Internally finished in matt RAL/NCS lacquer. Built-in marble top. Internal LED lights available. Handles can be finished in any lacquer of the metal lacquer finish selection.

vedi anche/see also KINGS CROSS pouf-pouffe, KINGS CROSS tavolino tondo-round low table, KINGS CROSS tavolo basso-low table, KINGS CROSS consolle-console, KINGS CROSS cassetiera-chest of drawers, KINGS CROSS mobile trucco-make-up unit

[click here](#)

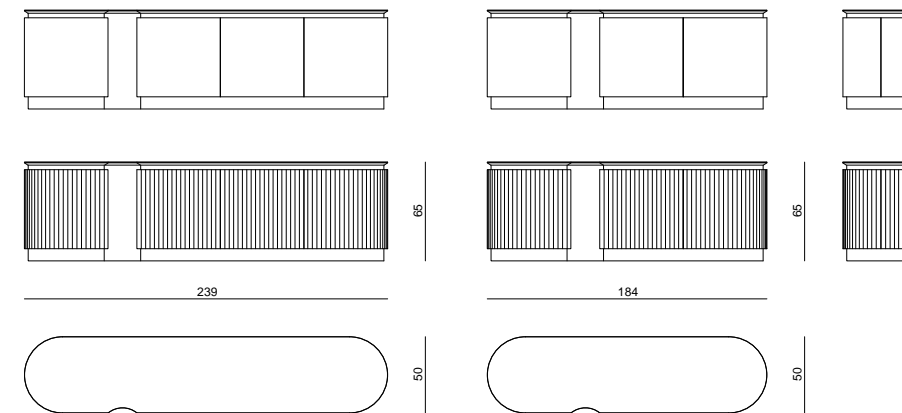
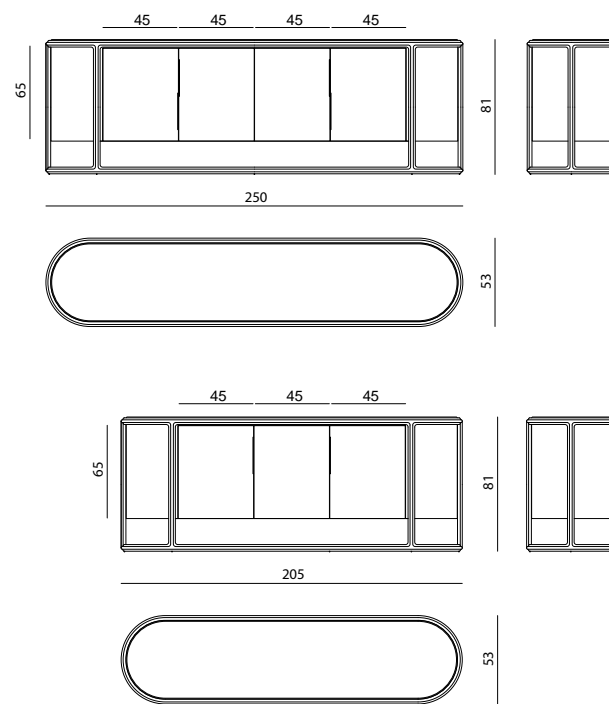

VERSIONE RADICA/ RADICA VERSION

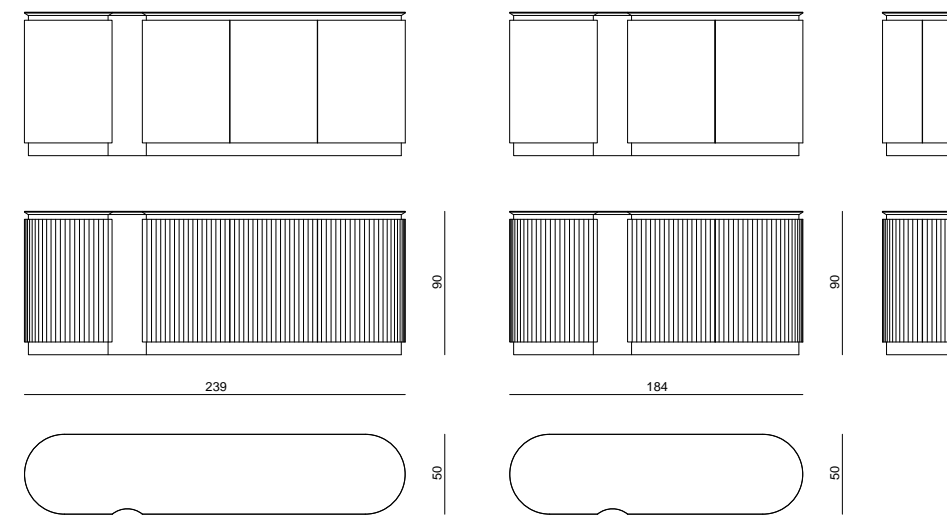

LEONARDO

MOBILE BASSO - LOW UNIT

Alessandro La Spada

Mobile basso a quattro ante con lati curvi, struttura in legno composta da uno zoccolo, un profilo sotto-top e un montante rivestiti in acciaio inox lucido curvato in porzioni concave e convesse. Ante e fianchi scolpiti con lavorazione superficiale "canneté" in bassorilievo sono disponibili con verniciatura lucida (colori RAL/NCS), oppure in colori metallizzati a campionario, oppure rivestiti in pelle Soft leather. Interni laccati con colori RAL/NCS opaco. I profili decorativi in acciaio inox curvato sono disponibili nella selezione finiture metalliche. Top in appoggio in marmo lucidato con profilo inferiore bisellato. Disponibile con illuminazione interna a LED.

Disponibile nella versione LEONARDO RADICA con ante e fianchi lisci curvi in radica con finitura lucida 100 gloss.

Low unit with four doors and curved sides, structure in wood with plinths, under-top profile and supporting pillar covered in shiny stainless steel, curved as to design convex and concave shapes. Doors and sides decorated with 'canneté' stripes carved in low relief, available in one of the following finishes: shiny lacquer (RAL/NCS colours) finish; metal colours as per sampler; upholstered in Soft leather. Internally finished with matt RAL/NCS lacquer. Decorative profiles in curved stainless steel can be finished with any lacquer of the metal lacquer finish selection. Counter top in polished marble with bevelled lower profile. Optional: internal LED lights.

Available in the LEONARDO RADICA version with smooth doors and curved sides in briarwood with a 100 gloss finish.

vedi anche/see also LEONARDO letto-bed, LEONARDO comodino-bedside table, LEONARDO cassetiera-chest of drawers, LEONARDO consolle portalavabo-wellness unit, LEONARDO mobile bar-bar unit, LEONARDO libreria-bookshelf, LEONARDO armadio-wardrobe

[click here](#)

LEONARDO

MOBILE ALTO - HIGH UNIT

Alessandro La Spada

Mobile alto a quattro ante con lati curvi, struttura in legno composta da uno zoccolo, un profilo sotto-top e un montante rivestiti in acciaio inox lucido curvato in porzioni concave e convesse. Ante e fianchi scolpiti con lavorazione superficiale "canneté" in bassorilievo sono disponibili con verniciatura lucida (colori RAL/NCS), oppure in colori metallizzati a campionario oppure rivestiti in pelle Soft leather. Interni con un cassetto laccati con colori RAL/NCS opaco. I profili decorativi in acciaio inox curvato sono disponibili nella selezione finiture metalliche. Top in appoggio in marmo lucidato con profilo inferiore bisellato. Disponibile con illuminazione interna a LED.

Disponibile nella versione LEONARDO RADICA con ante e fianchi lisci curvi in radica con finitura lucida 100 gloss.

High unit with four doors with shaped sides; structure in wood with plinth, under-top profile and supporting pillar covered in polished curved stainless steel, with convex and concave shapes. Doors and sides decorated with 'canneté' stripes carved in low relief, available with: shiny lacquer (RAL or NCS colours) finish; metal colours as per sampler; upholstery in Soft leather. Drawers internally finished with matt RAL/NCS lacquer. Decorative profiles in curved stainless steel, with optional finish in any lacquer of the metal lacquer finish selection. Counter top in polished marble with bevelled lower edge. Optional: internal LED lights.

Available in the LEONARDO RADICA version with smooth doors and curved sides in briarwood with a 100 gloss finish.

vedi anche/see also LEONARDO letto-bed, LEONARDO comodino-bedside table, LEONARDO cassetiera-chest of drawers, LEONARDO consolle portalavabo-wellness unit, LEONARDO mobile bar-bar unit, LEONARDO libreria-bookshelf, LEONARDO armadio-wardrobe

[click here](#)



LISBET

MOBILE BASSO - LOW UNIT

Steve Leung

Mobile basso a quattro ante in legno. Mobile in legno verniciato con effetto nuvolato artistico in tre colori (verde, blu, rosso) o con effetto materico "moon gold", oppure in tinte RAL/NCS lucido. Le ante esterne hanno sagoma scatolata, incernierate sul fianco del mobile. Basamento in legno massello di frassino scolpito e tinto opaco. Top in marmo di 3 cm di spessore con bordo svasato perimetrale.

Low cabinet in wood with four doors. Wooden cabinet painted with artistic cloud effect in three colours (green, blue, red) or with 'moon gold' material effect, or in RAL/NCS glossy colours. The outer doors are box-shaped, hinged to the side of the cabinet. Base in solid ash wood, carved and matt stained. Internal glass shelves and an internal drawer. Marble top 3 cm thick with perimeter flared edge.

vedi anche/see also LISBET madia-cabinet

● [click here](#)

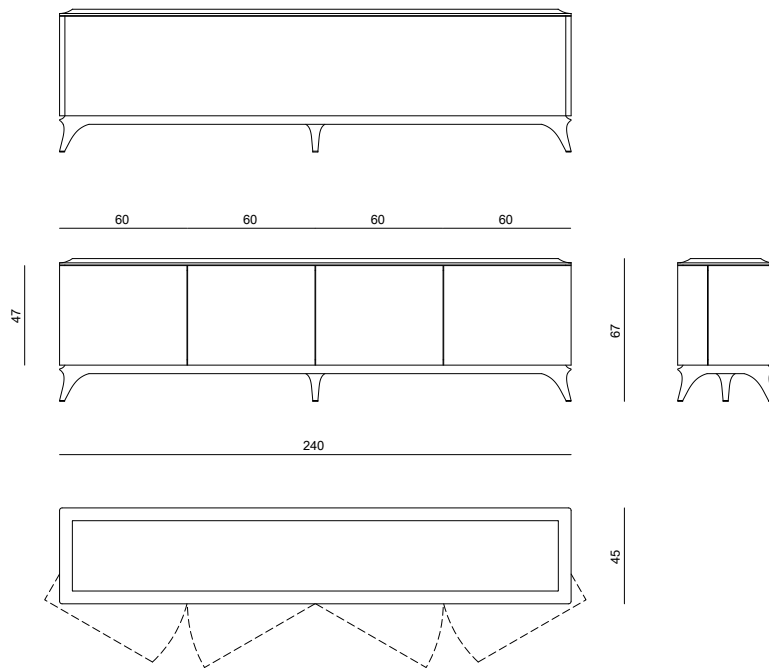

LISBET

MADIA - CABINET

Steve Leung

Madia a quattro ante in legno. Mobile in legno verniciato con effetto nuvolato artistico in tre colori (verde, blu, rosso) o con effetto materico "moon gold", oppure in tinte RAL/NCS lucido. Le ante esterne hanno sagoma scatolata, incernierate sul fianco del mobile. Basamento in legno massello di frassino scolpito e tinto opaco. Ripiani interni in cristallo e un cassetto interno. Top in marmo di 3 cm di spessore con bordo svasato perimetrale.

Sideboard in wood with four doors. Wooden cabinet painted with artistic cloud effect in three colours (green, blue, red) or with 'moon gold' material effect, or in RAL/NCS glossy colours. The outer doors are box-shaped, hinged to the side of the cabinet. Base in solid ash wood, carved and matt stained. Internal glass shelves and an internal drawer. Marble top 3 cm thick with perimeter flared edge.

vedi anche/see also LISBET mobile basso-low unit

● [click here](#)

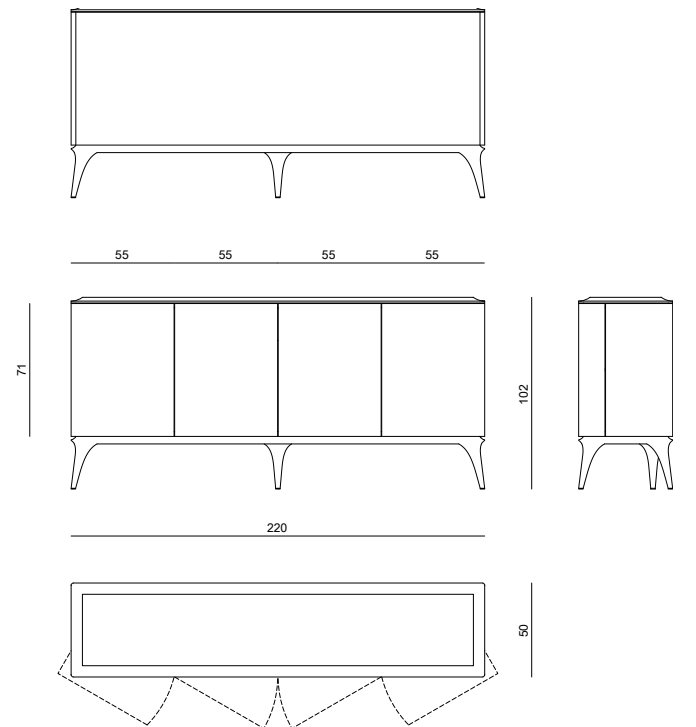
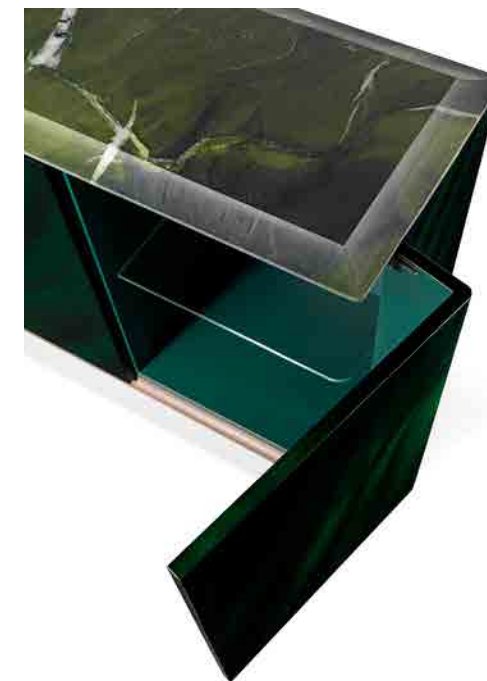

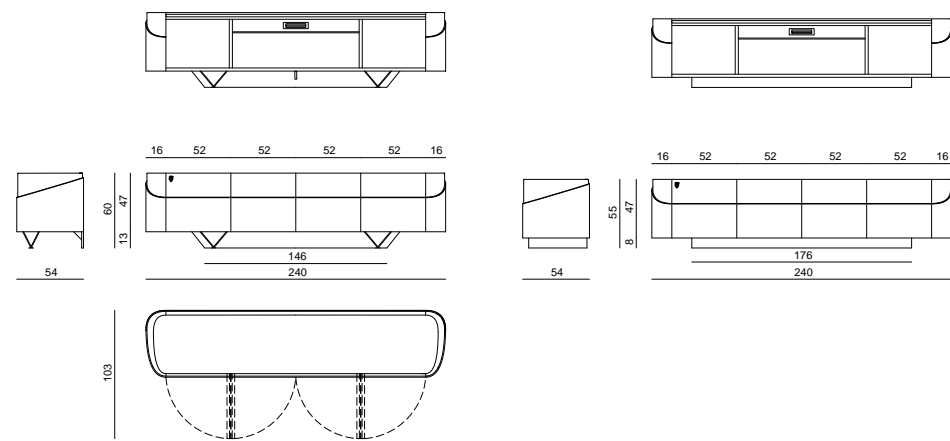

MAJESTIC

MOBILE BASSO - LOW UNIT

La Conca

Mobile basso a 4 ante, scocca in MDF sagomato con fianchi curvi, con superfici laccate (colori RAL) e parte inferiore rivestita in pelle o tessuto, separate da un profilo in acciaio inox lucido con traiettoria inclinata. Top incassato in marmo lucidato. Basamento in legno rivestito in acciaio inox lucido, oppure piedi in acciaio inox lucido con elementi tubolari a disposizione piramidale. Logo Visionnaire in ottone cromato sullo sportello sinistro. Ripiano interno in cristallo extra-chiaro e passacavi per device nel vano centrale. Le parti metalliche sono disponibili nella selezione finiture metalliche. Il rivestimento inferiore esterno è disponibile con lavorazione a trapunta cannettata con cuciture tono su tono.

Low unit with 4 doors, external structure in shaped MDF with curved sides, lacquered surface (RAL colours) and lower part upholstered in leather or fabric, divided by a polish stainless steel sloping profile. Built-in top in polished marble. Wooden base covered in polished stainless steel, or feet in polished stainless steel with tubular elements shaped as a pyramid. Visionnaire logo in chromed brass on the left door. Internal shelf in extra clear crystal glass and cable passage for devices available in the central compartment. Metal parts are available in polished and satin metal lacquered finish. External lower upholstery available with cannetté quilting with tone on tone stitching.

● [click here](#)

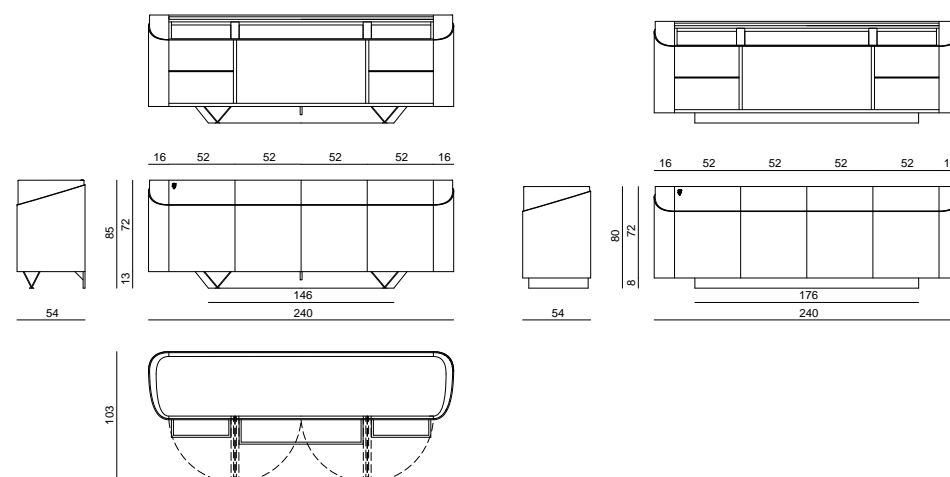

MAJESTIC

MADIA - CABINET

La Conca

Madia a 4 ante, scocca in MDF sagomato con fianchi curvi, con superfici laccate (colori RAL) e parte inferiore rivestita in pelle o tessuto, separate da un profilo in acciaio inox lucido con traiettoria inclinata. Top incassato in marmo lucidato. Basamento in legno rivestito in acciaio inox lucido, oppure piedi in acciaio inox lucido con elementi tubolari a disposizione piramidale. Logo Visionnaire in ottone cromato sullo sportello sinistro. Cassetti interni nei 3 vani, con ripiani in cristallo extra-chiaro. Le parti metalliche sono disponibili nella selezione finiture metalliche. Il rivestimento inferiore esterno è disponibile con lavorazione a trapunta cannettata con cuciture tono su tono.

High unit with 4 doors, external structure in shaped MDF with curved sides, lacquered surface (RAL colours) and lower part upholstered in leather or fabric, divided by a polish stainless steel sloping profile. Built-in top in polished marble. Wooden base covered in polished stainless steel, or feet in polished stainless steel with tubular elements shaped as a pyramid. Visionnaire logo in chromed brass on the left door. 3 compartments equipped with internal drawers and extraclear glass shelves. Metal parts available with polished and satin metal lacquered finish. Lower external upholstery available with cannetté quilting with tone on tone stitching.

● [click here](#)

MAREK

MADIA, MOBILE BASSO - CABINET, LOW CABINET

Roberto Lazzeroni

Mobile credenza a 4 ante in MD con top in marmo, zoccolo di base raggiati al pantografo. Internamente corredato da n. 5 ripiani principali. Finitura esterna laccato lucido poliestere spazzolato. Finitura interna laccato opaco. Elemento maniglia in legno con applicazione di formella in ceramica artistica lavorata a mano e con logo Visionnaire a rilievo.

Mobile basso a 4 ante in MD con top in marmo, zoccolo di base raggiati al pantografo. Finitura esterna laccato lucido poliestere spazzolato. Finitura interna laccato opaco. Elemento maniglia in legno con applicazione di formella in ceramica artistica lavorata a mano e con logo Visionnaire a rilievo.

High cabinet with 4 doors in MD with top in marble, plinth with pantograph-bent edges. Equipped with 5 shelves. External finishing in shiny brushed polyester lacquer. Internal finishing in mat lacquering. Handle in wood with artistic ceramic tile, hand-made and with embossed Visionnaire logo.

Low cabinet with 4 doors in MD with top in marble, plinth with pantograph-bent edges. External finishing in shiny brushed polyester lacquer. Internal finishing in mat lacquering. Handle in wood with artistic ceramic tile, hand-made and with embossed Visionnaire logo.

● [click here](#)

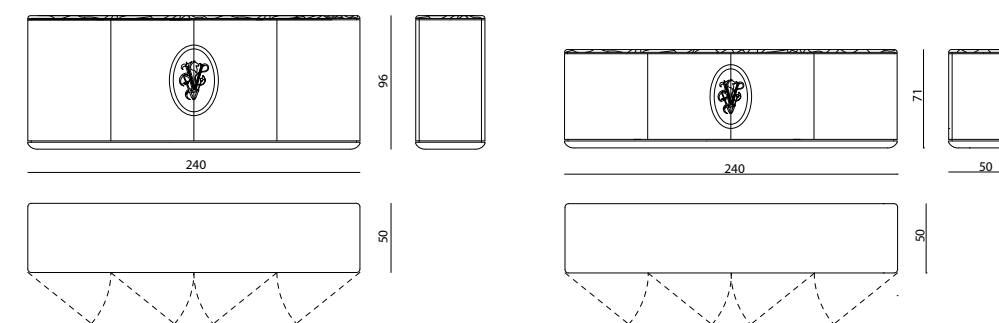

MIDNIGHT

MADIA - CABINET

Alessandro La Spada - Samuele Mazza

Struttura in multistrati e massello di abete. Rivestimento in vetro da mm 6, bisellato su tutti i lati, disponibile nei colori di serie. Interno laccato opaco con un ripiano.

Structure in plywood and solid fir. Cover in 6 mm thick glass bevelled on all sides, available in standard colours. Inner matt lacquered with shelves.

vedi anche/see also MIDNIGHT cassettera-chest of drawers, MIDNIGHT specchiera-mirror

● [click here](#)

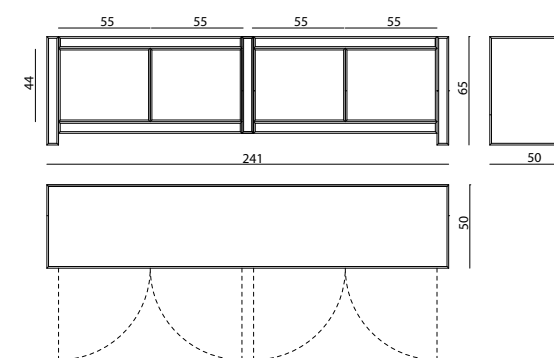



NADIR

MADIA - CABINET
Steve Leung

Madia a quattro ante in legno laccato lucido nei colori RAL/NCS, provvista di due cassetti interni. Il mobile presenta una gola in acciaio inox satinato per l'apertura delle ante. Le ante sono rivestite in pelle, gli interni sono verniciati in colore nero opaco. Gambe in metallo satinato disponibili nella selezione finiture metalliche.

Cabinet with four doors in wood, lacquered with RAL/NCS colours, equipped with two internal drawers. Finger groove handles for doors in satin stainless steel. Doors upholstered in leather, internal parts with matt black lacquer finish. Metal legs can be finished with any lacquer of the satin metal lacquer finish selection.

vedi anche/see also NADIR consolle-console

● click here

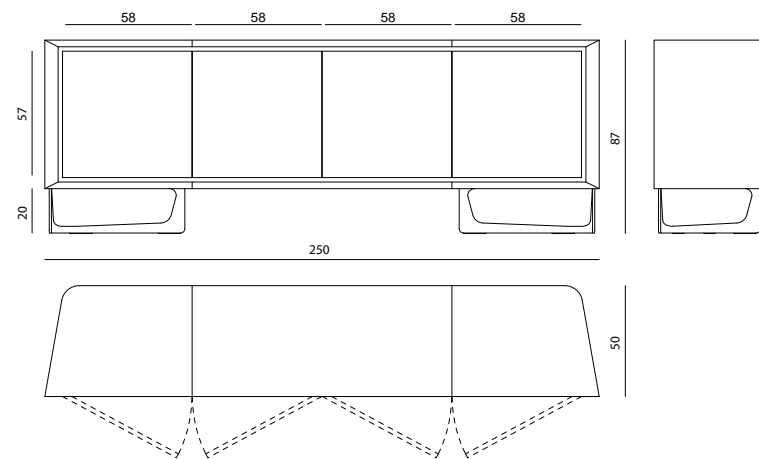

NOMOS

MOBILE ALTO - CABINET
Roberto Lazzeroni

Mobile alto con 4 ante, corpo centrale semi-ellittico in legno curvato su tutti i lati, superficie esterna con profili a rilievo, finitura laccato lucido. Top in marmo inserito in una cornice sagomata in legno massello di rovere con finitura nera a poro aperto. Base conica in legno nero e profilo inferiore in metallo satinato. Interno mobile provvisto di ripiani e cassetti, finito in radica di eucalipto con finitura a poro aperto e schienali a specchio fumé. Cassetti rivestiti in cuoio con interno in microfibra. Disponibile con illuminazione interna a LED. Disponibile nella versione "Wall" con schienale piatto.

Cabinet with 4 doors, semi-elliptical central body in curved wood on all sides, external surface with raised profiles, glossy lacquered finish. Marble top inserted in a molded frame in solid Oak wood with black open-pore finish. Conical base in black wood and lower profile in satin metal. Interiors with shelves and drawers, finished in eucalyptus root with open pore finish and smoked mirror backs. Drawers covered in leather with microfibre lining. Available with internal LED lighting. Also available in the "Wall" version with flat back.

vedi anche/see also NOMOS comodino-bedside table, NOMOS cassetiera-chest of drawers

● click here

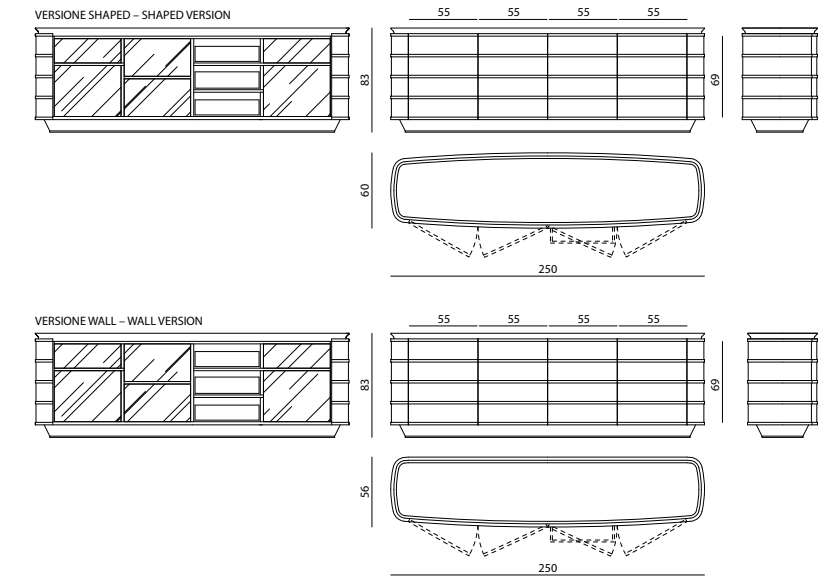

PALAWAN

MADIA, MOBILE BASSO - CABINET, LOW CABINET
Steve Leung

Mobile in legno laccato lucido, interno lucido, 4 ante in specchio (naturale - bronzo - fumé) curvato e inciso, con maniglie in alluminio e nappine in pelle (opzionali). Top in vetro nero, basamento sagomato con gambe in faggio laccato. Schienale tamburato di grosso spessore rivestito in pelle o tessuto. Profili di top, base e schienale in acciaio inox lucidato, piedi in acciaio satinato. Le parti metalliche sono disponibili nella selezione finiture metalliche.

Polished lacquered wood unit, internal part polished matt, 4 doors in curved engraved mirror (natural - bronze - smoked), handles in aluminium and tassels in leather (optional). Top in black glass. Shaped base and legs in polished lacquered beech wood. Back part in thick plywood covered in fabric or leather. Top, base and back profiles are in polished stainless steel with legs in brushed steel. Metal parts can be lacquered in any colour included in the metal finish selection.

vedi anche/see also PALAWAN mobile bar-bar cabinet

● click here

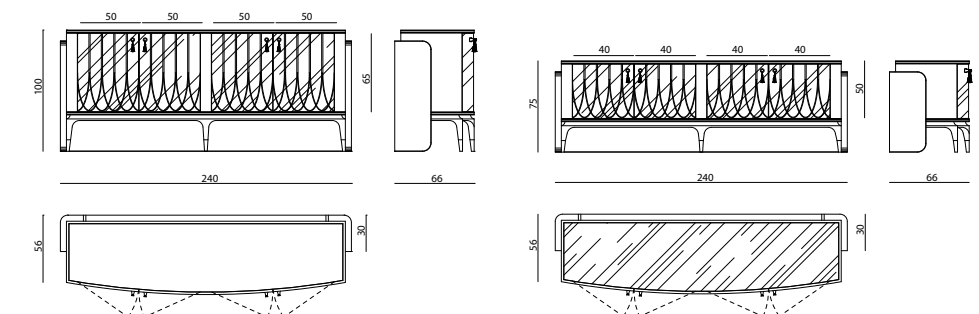



PANAY

MADIA, MOBILE BASSO - CABINET, LOW CABINET
Steve Leung

Mobile in legno laccato lucido con quattro ante in specchio (naturale, bronzo o fumé) curvato e inciso, con maniglie in alluminio. Top in vetro nero o a specchio in tinta con le ante, profili di top e base e piedini in acciaio inox lucidato. Le parti in metallo sono disponibili nella selezione finiture metalliche.

Cabinet/Low cabinet in shiny lacquered wood with four doors in shaped and engraved mirror (natural, bronze or smoked), with aluminium handles. Top in black glass or mirror glass matching the finish of the doors; top profiles, base and feet in shiny stainless steel. Metal components can be finished with any lacquer of the metal lacquer finish selection.

vedi anche/see also PANAY mobile bar-bar cabinet

● [click here](#)

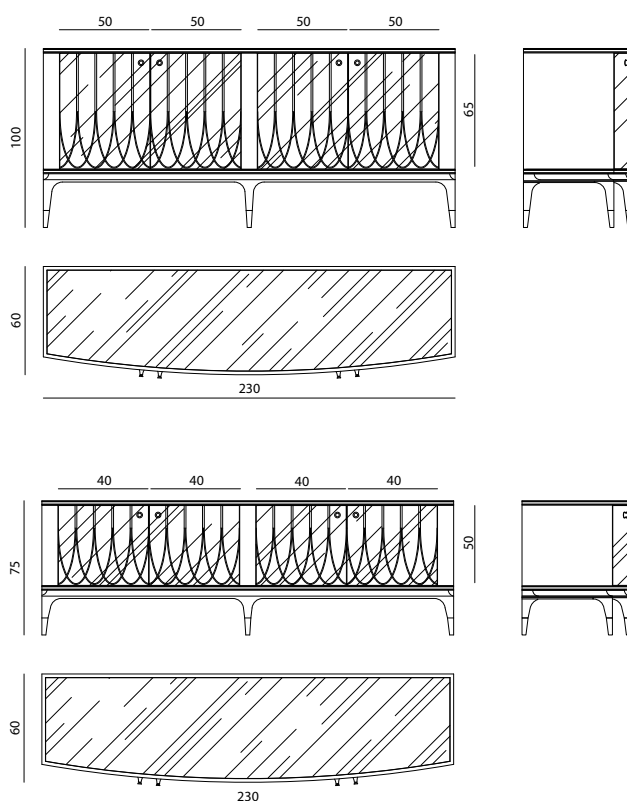

PARKER

MOBILE BASSO - LOW CABINET
Fabio Bonfà

Mobile basso a quattro ante e due cassetti. Struttura in MDF rivestita in essenza con inserti in acciaio inox satinato incastonati nel legno. Ante in legno scolpito in bassorilievo con disegno a rombi, top in marmo. Base con piedi in acciaio inox satinato, Interno laccato opaco, schienale laccato opaco, in opzione disponibile in essenza. Le parti in legno sono disponibili nelle finiture opache B.180, B.181, B.182, C.001. Le parti metalliche sono disponibili nella selezione finiture metalliche satinato.

Disponibile nella versione PARKER RADICA con frontale cassetti e struttura principale in radica con finitura lucida 100 gloss, ante in legno laccato lucido (colori RAL/NCS).

Low cabinet with four doors and two drawers. Structure in MDF covered in wood with inserts in satin stainless steel embedded in the wood. Wooden doors carved in low relief with diamond pattern, marble top. Base with feet in brushed stainless steel, matt lacquered interior, matt lacquered back, optional available veneered. The wooden parts are available in matt finishes B.180, B.181, B.182, C.001. Metal parts available in the satinized metal finishing selection.

Available in PARKER RADICA version with drawer front and main structure in briarwood with 100 gloss finish, doors in glossy lacquered wood (RAL/NCS colours).

● [click here](#)



VERSIONE RADICA/RADICA VERSION

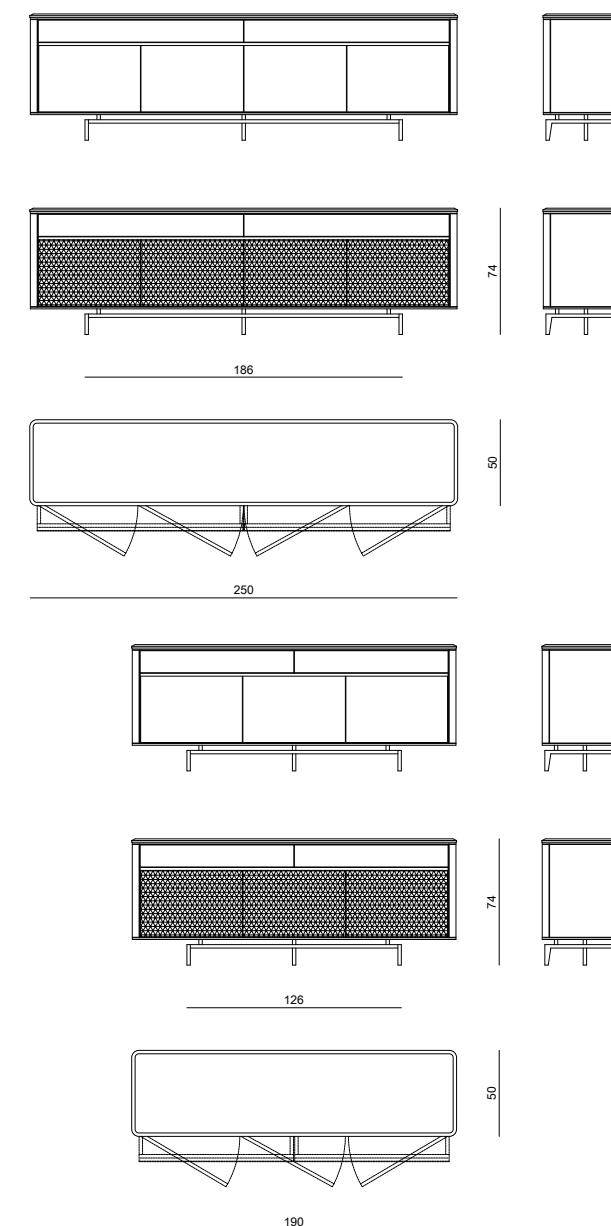

RAWDON

MOBILE BASSO - LOW CABINET

La Conca

Mobile a doppia profondità con 4 ante oppure 4 cassetti ad apertura push-pull con finitura laccata lucida o rivestita in essenza. Interno laccato opaco (colori RAL), fianchi e top rivestiti in pelle. Cornice perimetrale incassata rivestita in specchio (naturale/bronzo/fumè) con effetto "labirinto". Profili frontali in acciaio inox lucido oppure disponibili nella selezione finiture metalliche. Le parti in legno sono disponibili nelle finiture selezione essenze.

Unit with double depth with 4 doors or 4 drawers and push-pull opening. The doors and drawers can be lacquered and polished or in veneered wood. Mat lacquered inside (RAL colours), top and laterals upholstered in leather. Perimetral built-in frame covered with "labyrinth effect" mirror (natural/bronze/fume). Frontal outline in polished stainless steel or can be lacquered in any colour included in the metal finish selection. Wooden parts are available with veneer selection finishings.

vedi anche/see also RAWDON mobile trucco-make-up cabinet, RAWDON cassettiere-chest of drawers

● click here

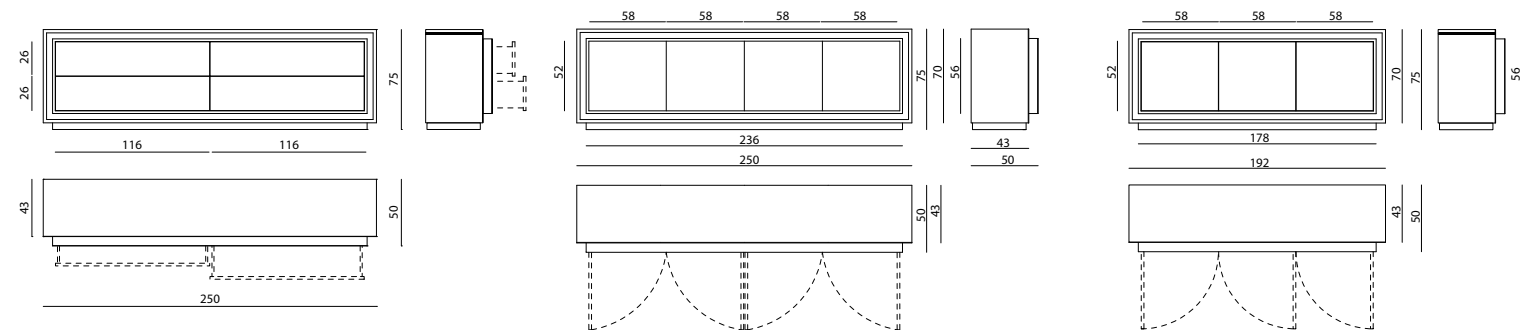

RUSKIN

MOBILE BASSO - LOW CABINET

La Conca

Mobile con 4 ante rivestite in pelle. Ante ad apertura push-pull in legno laccato a colori RAL/NCS laccato o rivestite in essenza. Interno laccato opaco (colori RAL/NCS). Le cornici perimetrali delle ante sono rivestite in specchio con profili frontali in acciaio inox lucido. Disponibile anche nella versione a 4 cassetti. Le parti in metallo sono disponibili nella selezione finiture metalliche, le parti in essenza sono disponibili nella selezione essenze.

Low cabinet with four doors upholstered in leather. Doors with push-pull opening in wood, available with RAL/NCS lacquer finish or veneer finish. Internal parts with matt lacquer finish (RAL/NCS colours). Door frames covered in mirror with profiles in shiny stainless steel. Available in version with drawers. Metal components can be finished in any lacquer of the metal lacquer finish selection. Wooden parts available with any finish included in the wood veneer finish selection.

● click here

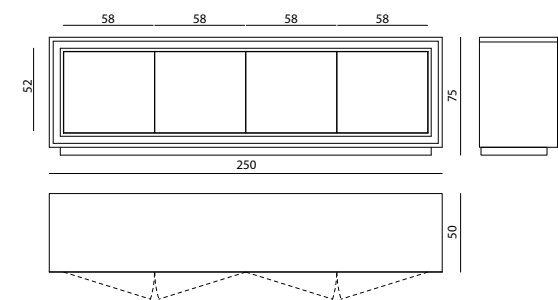

WOODY

MADIA, MOBILE BASSO - CABINET, LOW CABINET

La Conca

Mobile in legno rivestito in specchio satinato con tutti i bordi bisellati lucidi, interni laccati RAL/NCS opaco. Lo specchio del rivestimento è disponibile nei colori naturale, bronzo e fumè.

Wooden unit covered in satin mirror glass with polished bevelled edges, internally lacquered with matt RAL/NCS colours. Mirror glass available with natural, bronze or smoked finish.

vedi anche/see also WOODY tavolo basso-low table, WOODY cassettiere-chest of drawers

● click here

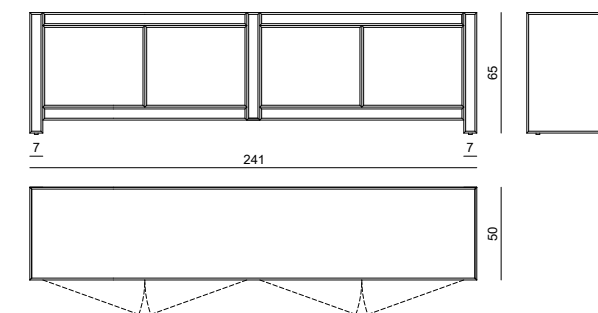
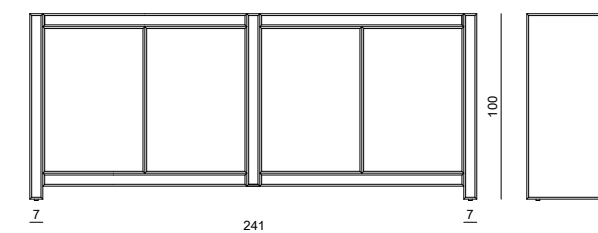

ARCHINTO

MADIA - CABINET

Giuseppe Viganò

Struttura e top in legno laccato lucido 100 gloss (disponibile in colore nero o colori RAL scuri) con inserti decorativi in ottone naturale e madreperla sotto lacca trasparente. Gambe coniche in metallo cromato con puntale in fusione di ottone lavorata a bassorilievo, impreziosita con gemma taglio diamante in ametista viola. Ante con maniglie a griglia in alluminio cromato con incastonatura di madreperla. Le parti in metallo sono disponibili nella selezione finiture metalliche.

Top and body in polished lacquered wood 100 gloss (available in black or dark RAL colours) with decorative inserts in natural brass and mother of pearl decorations applied on transparent varnish. Conical chromed metal legs with brass cast studs in bas-relief, enriched with diamond shaped gems in purple amethyst. Doors with chromed aluminium grid handles and built-in mother of pearl. Metal parts available in the metal finishing selection.

vedi anche/see also ARCHINTO consolle-console,
ARCHINTO mobile bar-bar cabinet

[● click here](#)

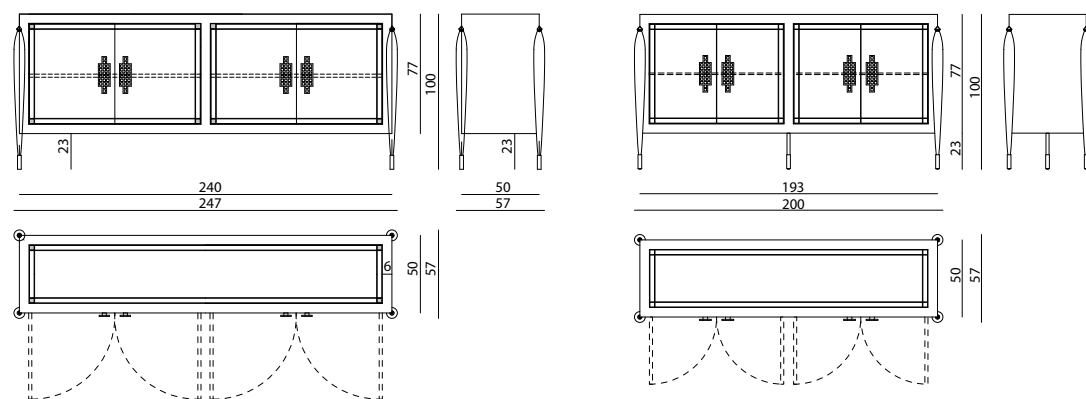

- click on the icons -



AZIMUT p.298



BARNEY p.298



BARRYMORE p.299



DANNY p.299



DANTE p.300



HAMILTON p.300



KINGS CROSS p.301



LEONARDO p.301



NOMOS p.302



PERKINS p.302



RAWDON p.303



WOODY p.303

ICONICI - *ICONIC*



ALICE p.304



VASLAV p.304



VERSAILLES p.305

AZIMUT

CASSETTONE - CHEST OF DRAWERS

Steve Leung

Struttura in multistrati di legno a quattro cassetti, rivestita in pelle o laccata, gole e cornici delle ante in acciaio inox satinato, pannelli decorativi frontali in marmo oppure in pietra naturale a spacco vivo con inserti in acciaio inox lucido. Gambe in acciaio inox satinato. Le parti in acciaio sono disponibili satiniate nella selezione finiture metalliche.

Structure in plywood with 4 drawers, covered in leather or in lacquered wood, doors grooves and frames in satinized stainless steel, front decorative panels in marble or in natural cleft stone with inserts in shiny stainless steel. Legs in satinized stainless steel. Metal parts available in the satinized metal finishing selection.

vedi anche/see also AZIMUT consolle-console, AZIMUT madia-high unit

● [click here](#)

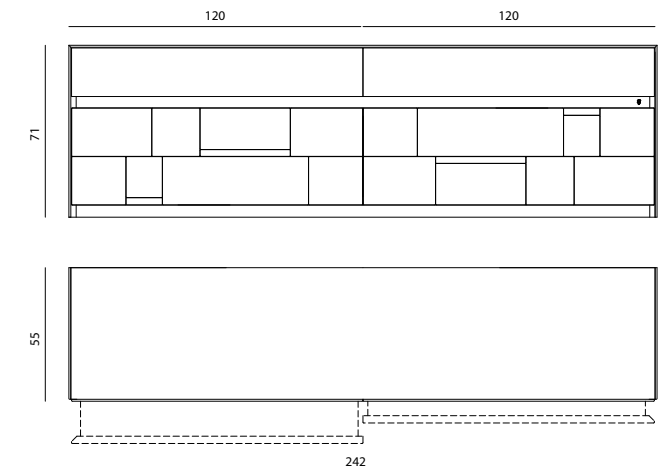
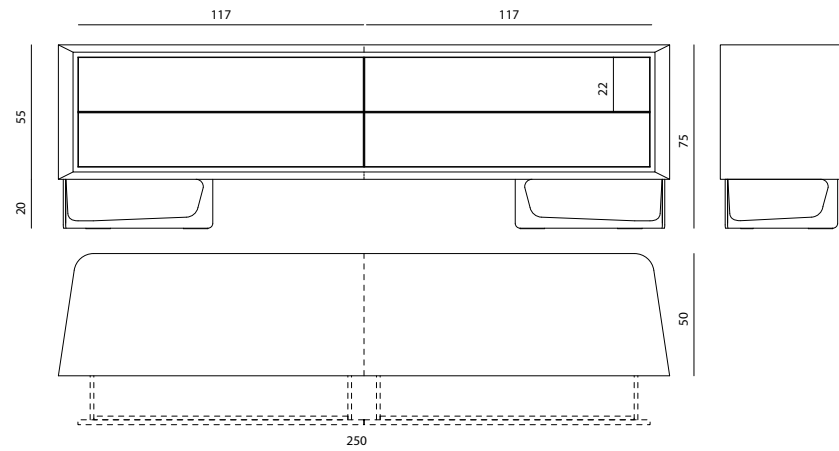

BARRYMORE

CASSETTIERA - CHEST OF DRAWERS

Alessandro La Spada

Comò interamente rivestito in pelle o tessuto con trama geometrica. Struttura in MDF leggermente imbottita in poliuretano sp. 5 mm, interno laccato opaco. Cassetti rivestiti con pannelli leggermente imbottiti e rivestiti a formare motivo a quadri; interno cassetti in multistrati di betulla laccato opaco e guide smorzate. Gole di apertura cassetti e inserti metallici in acciaio satinato. Zoccolo di base in multistrato di pino da 25 mm rivestito esternamente con lamina acciaio. Le parti metalliche sono disponibili nella selezione finiture metalliche.

Chest of drawers upholstered in leather or fabric with geometrical pattern. MDF structure slightly padded in polyurethane foam, 5 mm in width, matt lacquered internal part. Drawers covered in panels slightly padded and upholstered, creating a square pattern. Internal part of drawers in birch plywood with matt finishings and runners equipped with damping system. Runners for drawers and metal inserts in satinized steel. Plinth in 25 mm poplar plywood externally coated in laminated steel. Metal parts can be lacquered in any colour included in the metal finish selection.

vedi anche/see also BARRYMORE armadio-wardrobe

● [click here](#)



BARNEY

CASSETTIERA - CHEST OF DRAWERS

Fabio Bonfà

Cassettiera a 9 cassetti, struttura in mdf rivestita in essenza con inserti in acciaio inox satinato incastonati nel legno, grande maniglione e base in acciaio inox satinato, frontali cassetti in marmo a pieno spessore. Interno laccato opaco, schienale laccato opaco, in opzione disponibile in essenza. Le parti in legno sono disponibili nelle finiture selezione essenze, le parti metalliche sono disponibili nella selezione finiture metalliche.

Chest of 9 drawers, structure in MDF covered in veneer with inserts in satinized stainless steel embedded in the wood, big drawer handle and base in satinized stainless steel, doors in marble in full thickness, matt lacquered internal parts, matt lacquered backrest, available in veneer wood. Wooden parts available in the veneer finishing selection, metal parts available in the metal finishing selection.

vedi anche/see also BARNEY tavolo basso-low table, BARNEY mobile basso-low unit

● [click here](#)

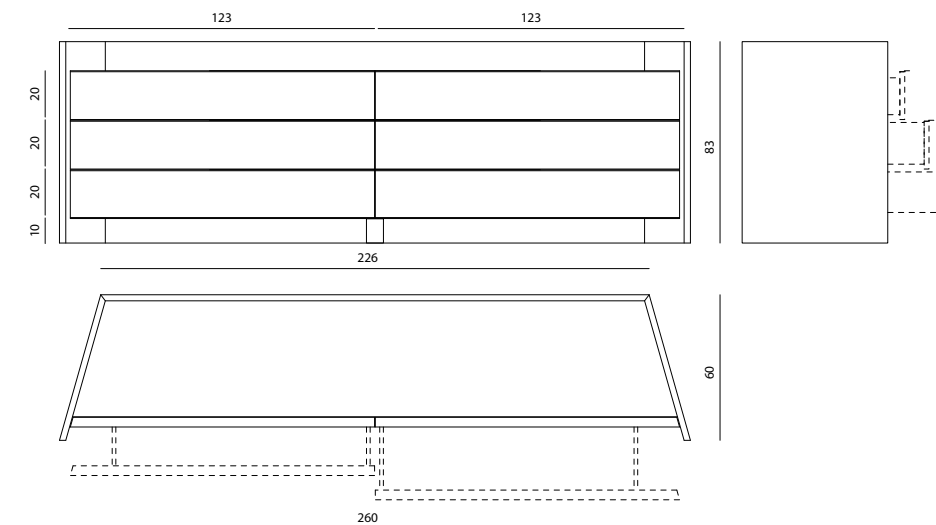
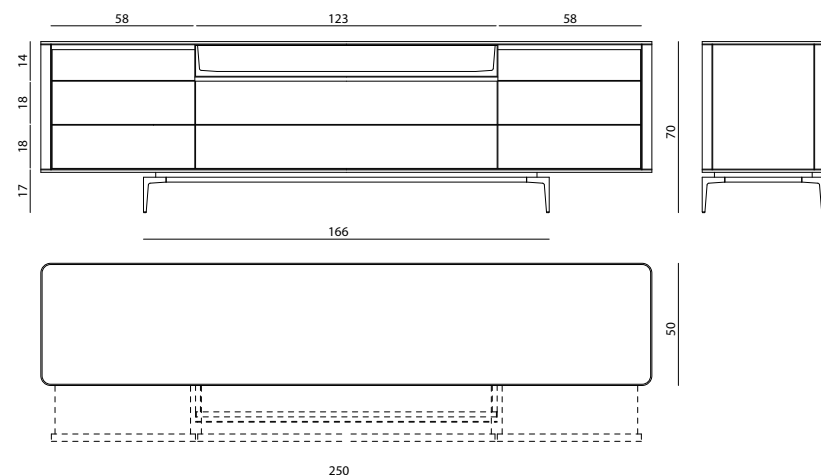

DANNY

CASSETTIERA - CHEST OF DRAWERS

Mauro Lipparini

Mobile con 6 cassetti, scocca del mobile in legno con lato esterno laccato lucido e superficie interna rivestita in acciaio satinato. Top e cassetti in essenza con maniglie in acciaio lucido e guide smorzate. Interno laccato opaco. Top e cassetti sono disponibili nelle finiture selezione essenze; le parti metalliche sono disponibili nella selezione finiture metalliche.

Chest of 6 drawers, main structure in wood with external side coated in satinized steel. Top and drawers in veneered wood with handles in polished steel and runners with damping system. Internal structure in matt lacquered. Top and drawers available with veneer selection finishings; metal parts can be lacquered in any colour included in the metal finish selection.

vedi anche/see also DANNY mobile basso-low cabinet, DANNY mobile trucco-vanity unit

● [click here](#)



DANTE

CASSETTIERA - CHEST OF DRAWERS

Alessandro La Spada

Cassettiera in legno con fianchi e top in essenza o laccati a finitura lucida 100 gloss. Cornice interna in acciaio inox curvato. Cassetti con frontale in tinta, interni laccati opaco. Le parti in metallo sono disponibili nella selezione finiture metalliche, le parti in legno sono disponibili nelle finiture selezione essenze oppure verniciate in colori RAL/NCS.

Chest of drawers with top and sides in veneered wood or lacquered with 100 gloss finish. Internal frame in curved stainless steel, interiors in matt lacquered finish. The metal parts are available in the metal finishes selection, the wooden parts are available in the veneer selection or lacquered in RAL/NCS colours.

[click here](#)

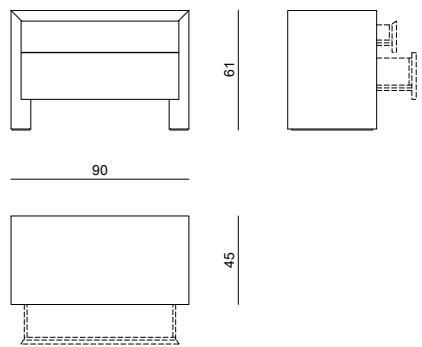

KINGS CROSS

CASSETTIERA - CHEST OF DRAWERS

Mauro Lipparini

Cassettiera a 6 cassetti e fianchi curvi. Struttura esterna portante in legno massello di noce canaletto con finitura naturale a poro aperto, scolpito con sezione sagomata a tre lobi, struttura interna in legno composta da ante e fianchi curvati, disponibili in finitura verniciata RAL/NCS lucido o rivestiti in pelle. Maniglie in metallo satinato. Interni laccati RAL/NCS opaco. Top in marmo incassato. Le maniglie sono disponibili nella selezione finiture metalliche.

Chest of six drawers and curved sides. Supporting frame in Canaletto walnut solid wood with open-pore natural finish and shaped three-lobes section; wooden structure with doors and curved sides, available with shiny RAL/NCS lacquer or leather upholstery. Handles in satin metal. Internally finished in matt RAL/NCS lacquer. Built-in marble top. Handles can be finished in any lacquer of the metal lacquer finish selection.

vedi anche/see also KINGS CROSS pouf-pouffe, KINGS CROSS tavolino tondo-round low table, KINGS CROSS tavolo basso-low table, KINGS CROSS consolle-console, KINGS CROSS mobile basso-low cabinet, KINGS CROSS mobile bar-bar unit, KINGS CROSS mobile trucco-vanity unit

[click here](#)

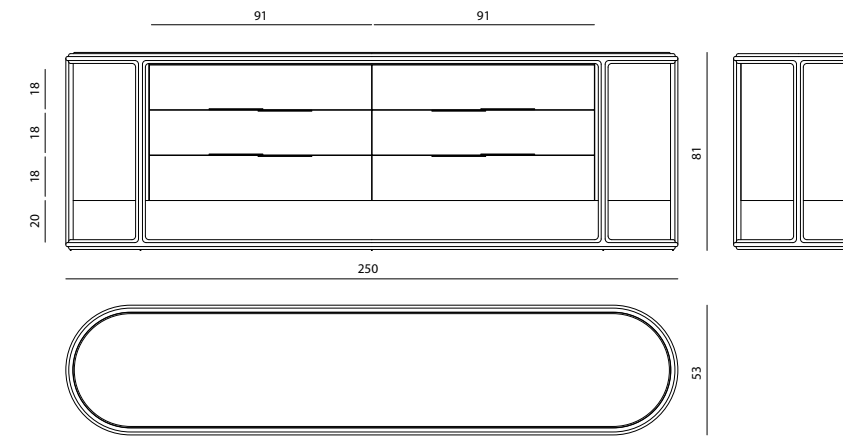

HAMILTON

CASSETTIERA - CHEST OF DRAWERS

Alessandro La Spada

Cassettiera a sei cassetti, struttura in legno con fianchi concavi in essenza e finitura manuale lucida 100 gloss oppure laccata lucida. La cornice interna dei fianchi e del top è rivestita in acciaio inox lucido curvato. Interni cassetti laccati RAL/NCS opaco. Le parti in metallo sono disponibili nella selezione finiture metalliche, le parti in legno sono disponibili nelle finiture selezione essenze oppure verniciate in colori RAL/NCS

Chest of six drawers, structure in wood with concave side in veneered wood finished with 100 gloss polish applied by hand or with shiny lacquer. Sides and top internal frame covered in curved stainless steel with shiny finish. Drawers internally finished with matt RAL/NCS lacquer. Metal parts can be finished with any lacquer of the metal lacquer finish selection. Wooden parts can be finished with any wood veneer of the veneer finish selection or with RAL/NCS lacquer.

vedi anche/see also HAMILTON media-cabinet, HAMILTON mobile basso-low unit

[click here](#)

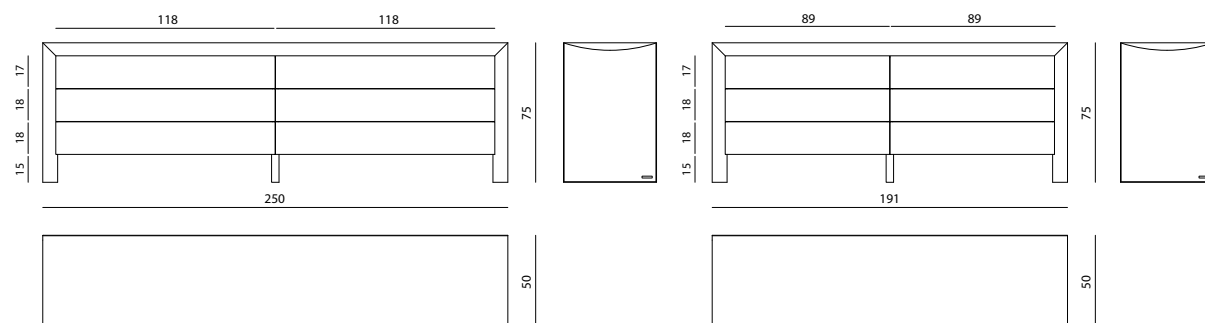

LEONARDO

CASSETTIERA - CHEST OF DRAWERS

Alessandro La Spada

Cassettiera a due cassetti e due ante curve, struttura in legno composta da uno zoccolo, un profilo sotto-top e un montante rivestiti in acciaio inox lucido curvato in porzioni concave e convesse. Ante e fianchi scolpiti con lavorazione superficiale "cannetè" in bassorilievo sono disponibili con verniciatura lucida (tinte RAL/NCS), oppure in colori metallizzati a campionario. Interni laccati con colori RAL/NCS opaco. I profili decorativi in acciaio inox curvato sono disponibili nella selezione finiture metalliche. Top in appoggio in marmo lucidato con profilo inferiore bisellato. Disponibile con illuminazione interna a LED nei vani laterali.

Disponibile in versione LEONARDO RADICA con ante e frontali cassetti lisci in radica con finitura lucida 100 gloss.

Chest of drawers with two drawers and two doors opening on the curved sides. Structure in wood composed by plinth, undertop profile and sustaining frame in curved polished stainless steel, alternating concave and convex shapes. Doors and sides decorated with hand-carved cannetè motif in low relief. They can be lacquered with polish finish in RAL/NCS colours, or in metal colours as per sampler. Internally lacquered in matt RAL/NCS colours. Decorative profiles in curved stainless steel available with any finish included in the metal finish selection. Top in polished marble with bevelled lower edge.

Available in LEONARDO RADICA version with smooth doors and drawer fronts in burr walnut with 100 gloss finish.

vedi anche/see also LEONARDO letto-bed, LEONARDO comodino-bedside table, LEONARDO cassettiera-chest of drawers, LEONARDO consolle portalavabo-wellness unit, LEONARDO mobile bar-bar unit, LEONARDO libreria-bookshelf, LEONARDO armadio-wardrobe

[click here](#)

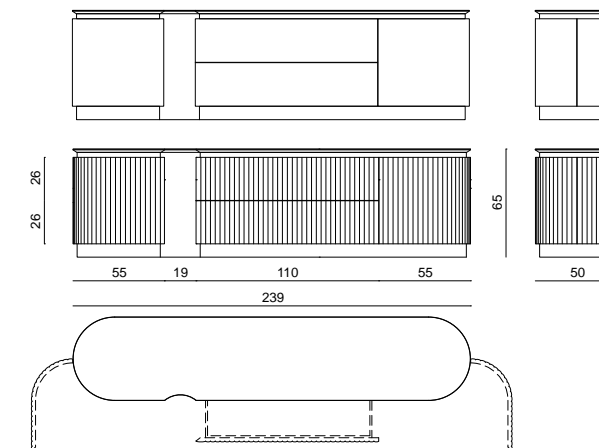

RETRO CANNETTATO
CANNETTE' REARBACK

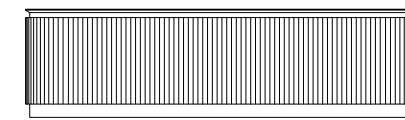

RETRO LISCIO LACCATO OPACO
MAT LACQUERED PLAIN REARBACK

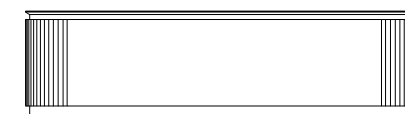

VERSIONE RADICA/ RADICA VERSION

NOMOS

CASSETTIERA - CHEST OF DRAWERS

Roberto Lazzeroni

Cassettiera a 6 cassetti con corpo centrale semi-ellittico in legno curvato su tutti i lati, superficie esterna con profili a rilievo, finitura laccato lucido. Top in marmo inserito in una cornice sagomata in legno massello di rovere con finitura nera a poro aperto. Base conica in legno nero e profilo inferiore in metallo satinato. Interno cassetti in essenza rovere nero e interno in microfibra nera. Disponibile nella versione "Wall" con schienale piatto.

Chest of drawers with 6 drawers with semi-elliptical central body in curved wood on all sides, external surface with raised profiles, glossy lacquered finish. Marble top inserted in a molded frame in solid Oak wood with black open-pore finish. Conical base in black wood and lower profile in satin metal. Drawers interiors in black oak and black microfibre inside. Also available in the "Wall" version with flat back.

vedi anche/see also NOMOS comodino-bedside table, NOMOS mobile alto-cabinet

● [click here](#)



VERSIONE SHAPED - SHAPED VERSION

VERSIONE WALL - WALL VERSION

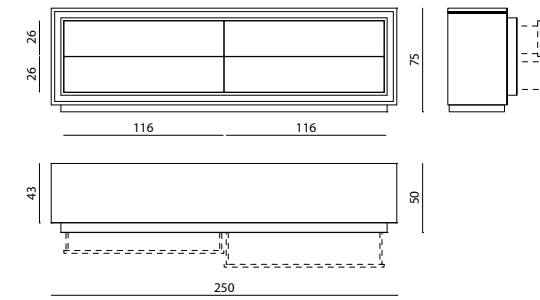
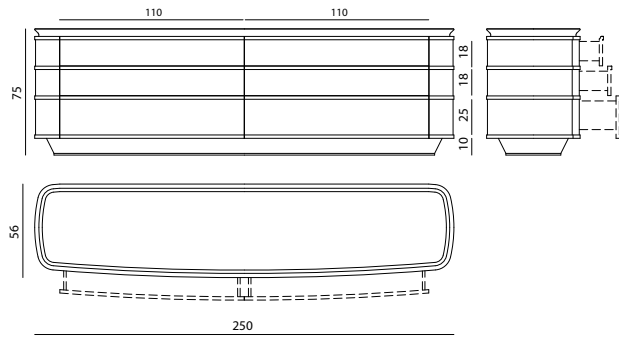
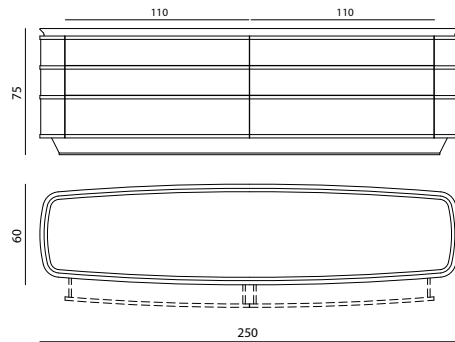

RAWDON

CASSETTIERA - CHEST OF DRAWERS

La Conca

Mobile a doppia profondità con 4 ante oppure 4 cassetti ad apertura push-pull con finitura laccata lucida o rivestita in essenza. Interno laccato opaco (colori RAL), fianchi e top rivestiti in pelle. Cornice perimetrale incassata rivestita in specchio (naturale/bronzo/fumè) con effetto "labirinto". Profili frontali in acciaio inox lucido oppure disponibili nella selezione finiture metalliche. Le parti in legno sono disponibili nelle finiture selezione essenze.

Unit with double depth with 4 doors or 4 drawers and push-pull opening. The doors and drawers can be lacquered and polished or in veneered wood. Mat lacquered inside (RAL colours), top and laterals upholstered in leather. Perimetral built-in frame covered with "labyrinth effect" mirror (natural/bronze/fume). Frontal outline in polished stainless steel or can be lacquered in any colour included in the metal finish selection. Wooden parts are available with veneer selection finishings.

vedi anche/see also RAWDON mobile trucco-make-up cabinet, RAWDON mobile basso-low cabinet

● [click here](#)

PERKINS

CASSETTIERA - CHEST OF DRAWERS

La Conca

Struttura in legno imbottito e tappezzato in pelle o tessuto, top in marmo. Fasce decorative laterali e base in acciaio inox lucido. Sei maniglie in ottone inciso, finitura cromo. Interno cassetti laccatura opaca (colori RAL/NCS). Le parti metalliche sono disponibili nella selezione finiture metalliche.

Wooden padded structure, upholstered in fabric or leather with marble top. Decorative lateral bands and base in polished stainless steel. Six handles in engraved chromed brass. Inner mat lacquered drawers (RAL/NCS colours). Metal parts can be lacquered in any colour included in the metal finish selection.

vedi anche/see also PERKINS letto-bed, PERKINS comodino-bedside table, PERKINS specchiera-mirror

● [click here](#)



WOODY

CASSETTIERA - CHEST OF DRAWERS

La Conca

Cassettiera a quattro cassetti in legno rivestito in specchio satinato con tutti i bordi bisellati lucidi, interni laccati RAL/NCS opaco. Lo specchio del rivestimento è disponibile nei colori naturale, bronzo e fumè.

Chest of four drawers in wood covered in satin mirror glass with polished bevelled edges, internally lacquered with matt RAL/NCS colours. Mirror glass available with natural, bronze or smoked finish.

vedi anche/see also WOODY tavolo basso-low table, WOODY media-cabinet

● [click here](#)

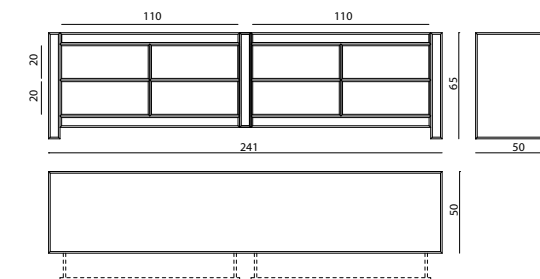
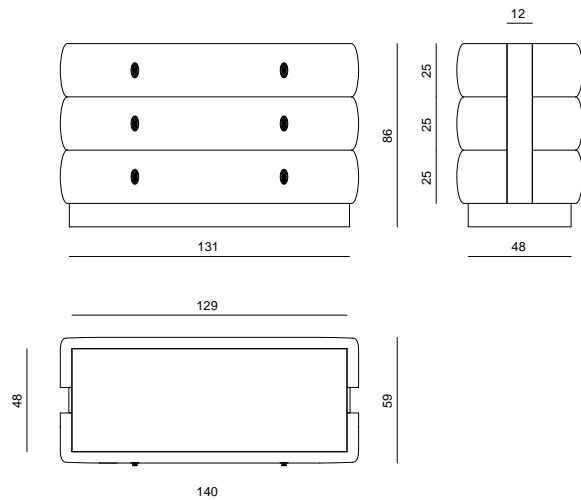

ALICE

CASSETTONE - CHEST OF DRAWERS

Alessandro La Spada

Top e struttura interna in MDF laccato lucido 100 gloss, 3 o 6 cassetti con maniglia a scudo in ottone e pelle. Struttura esterna curvata in multistrati di pioppo tappezzata in pelle o tessuto, fianchi ricamati a disegno "Lindoro". Base in acciaio inox lucido. Le parti metalliche sono disponibili nella selezione finiture metalliche.

Top and internal structure in 100 gloss lacquered MDF. 3 or 6 drawers with shield handle in brass and leather. Curved external structure in poplar plywood upholstered in leather or fabric. "Lindoro" embroidered on both sides. Polished stainless steel plinth. Metal parts can be lacquered in any colour included in the metal finish selection.

vedi anche/see also ALICE poltrona-armchair, ALICE chaise-longue, ALICE panca-bench, ALICE comodino-bedside table

● [click here](#)

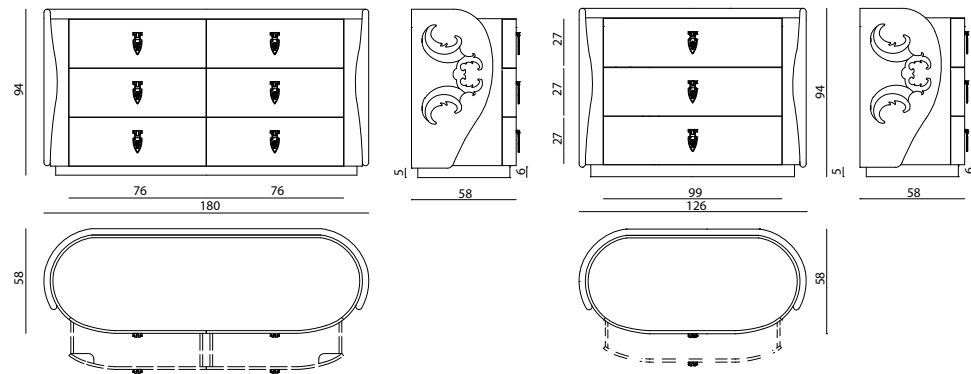

VERSAILLES

CASSETTIERA - CHEST OF DRAWERS

Alessandro La Spada

Cassettiera sagomata a 4 cassetti in MDF e compensato multistrati laccato lucido al poliestere spazzolato. Maniglia a scudo con inserto in pelle e stemma araldico Visionnaire in ottone finitura oro. Interno cassetti finitura opaca. Zoccolo in lamina d'acciaio inox. Le parti metalliche sono disponibili nella selezione finiture metalliche.

Shaped chest of 4 drawers in MDF and plywood, in shiny brushed polyester finishing. Shield handle with leather inser and Visionnaire coat of arms in gold brass. Internal drawers in mat finishing. Plinth in stainless steel laminate. Metal parts can be lacquered in any colour included in the metal finish selection.

vedi anche/see also VERSAILLES tavolo da pranzo-dining table, VERSAILLES consolle-console, VERSAILLES mobile bar-bar cabinet

● [click here](#)

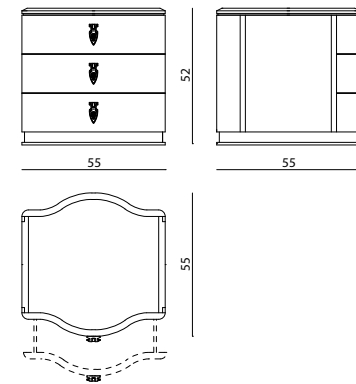

VASLAV

CASSETTIERA - CHEST OF DRAWERS

Maria Serebryanaya

Mobile cassettiera attrezzato con quattro cassetti e due ante. Struttura in MDF e multistrati curvato, ante rivestite in tessere di specchio con molatura sfaccettata a diamante (colori fumé/bronzo/naturale), in alternativa con lo stesso disegno è disponibile in legno laccato lucido colori RAL oppure tappezzata in tessuto o pelle, trapuntata a rombi. Profili di finitura in acciaio inox lucidato, top in specchio o vetro laccato bisellato, cornice top e basamento in legno laccato (colori RAL/NCS). Interni, retro e ripiani laccati opaco, frontali dei cassetti rivestiti in pelle o tessuto. Il cassetto superiore contiene un séparé portagioie rivestito in microfibra. In opzione: sistema di sicurezza per apertura del cassetto portagioie sotto combinazione con pannello di controllo touch-screen incorniciato in acciaio inox lucidato. Le parti metalliche sono disponibili nella selezione finiture metalliche.

Chest with 4 drawers and two doors. Plywood and MDF curved structure covered with diamond shaped mirror plates (fume, bronze or natural colours). The same design is available also in polished lacquered wood (RAL/NCS colours) or upholstered in fabric or leather, rhombuses quilted. Polished stainless steel outline, bevelled top in lacquered glass or mirror, top and basement frame in lacquered polished wood (RAL colours). Matt inside, back and shelves. Frontal drawers upholstered in fabric or leather. The upper drawer has a séparé for jewellery covered in microfiber. Option: safe system for opening of the jewellery drawer with a touch-screen control panel framed in polished stainless steel. Metal parts can be lacquered in any colour included in the metal finish selection.

● [click here](#)

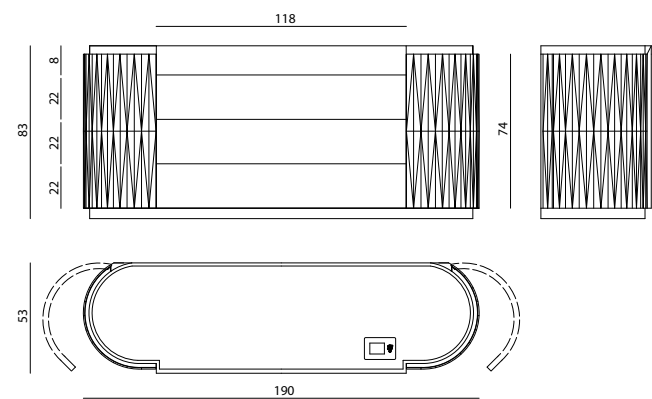

- click on the icons -



AURORA p.308



EQUINOX p.309



LEONARDO p.310



LISBET p.311



PALAWAN p.312



PANAY p.313



SERENDIPITY p.314

ICONICI - *ICONIC*



LARIX p.316



VERSAILLES p.317



AURORA

MOBILE BAR - BAR CABINET

Steve Leung

Struttura in legno laccato o in essenza, lucidato 100 gloss (sia esternamente che internamente). Ante ad apertura totale (180°), rivestite in marmo con intarsi e cornice in acciaio inox lucidato. Allestimento interno con 4 ripiani, 2 cassetti e mensole portaoggetti all'interno delle ante. Gambe in fusione di alluminio lucidato a specchio con puntali in alluminio satinato. Le parti in legno sono disponibili nelle finiture selezione essenze; le parti in metallo sono disponibili nella selezione finiture metalliche.

Structure in lacquered or veneered, polished in 100 gloss (both internally and externally). Doors with full-opening system (180°) covered in marble with inlays and frame in polished stainless steel. Internally equipped with 4 shelves, 2 drawers and storage shelves inside the doors. Legs in mirror-polished aluminium cast with tips in satinized aluminium. Wooden parts are available with veneer selection finishings; metal parts can be lacquered in any colour included in the metal finish selection.

vedi anche/see also AURORA consolle-consolle, AURORA media-high unit, AURORA mobile trucco-vanity unit

● click here

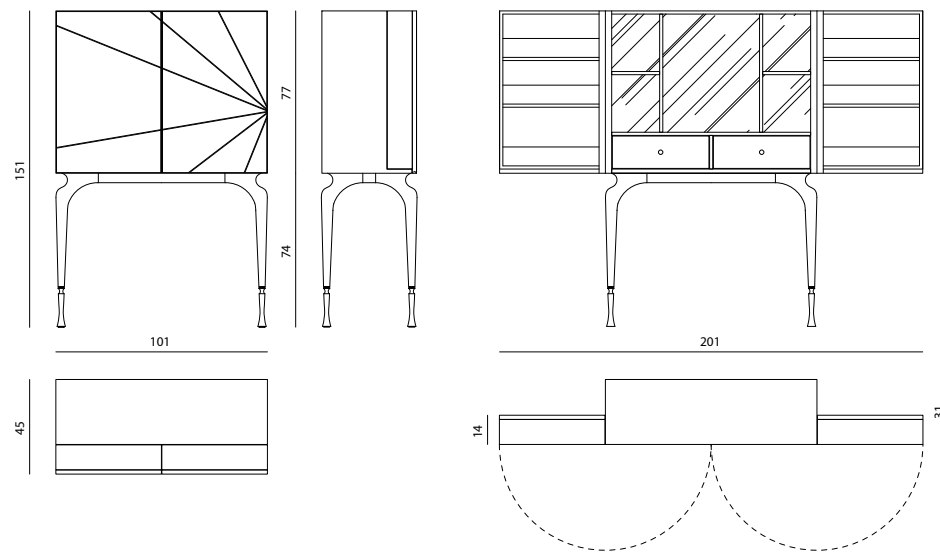

EQUINOX

CONSOLLE BAR - BAR CONSOLE

Mauro Lipparini

Consolle bar con struttura in multistrati e MDF con finitura laccata in colori RAL o perlata, oppure in essenza con finitura lucida. Pannello frontale in marmo lavorato ad arco con inserti in acciaio inox naturale e pelle. Fregio decorativo centrale e telaio esterno in acciaio inox satinato disponibile nella selezione finiture metalliche. Top apribile a ribalta con cerniere smorzate e vano interno laccato opaco con fondo a specchio e ripiani in cristallo extrachiaro. Mobile predisposto per attacco a parete. Opzione: impianto audio bluetooth integrato composto da 2 diffusori tweeter-mid range e una unità subwoofer (potenza max 400W) con prese USB per ricarica di dispositivi portatili.

Bar console with structure in plywood and MDF lacquered in RAL or pearlized colours or in veneer with shiny finishing. Front panel in marble with "arch" manufacture, with inserts in natural stainless steel and in leather. Central decoration and external frame in satinized stainless steel available in the satinized metal finishing selection. Flap top with damped hinges and internal part in mat lacquer with mirror bottom and shelves in extraclear crystal. Predisposed for wall fixing. Option: integrated Bluetooth audio system with 2 tweeter-mid range diffusers and 1 subwoofer unit (max 400W) with USB sockets for recharge of portable devices.

● click here

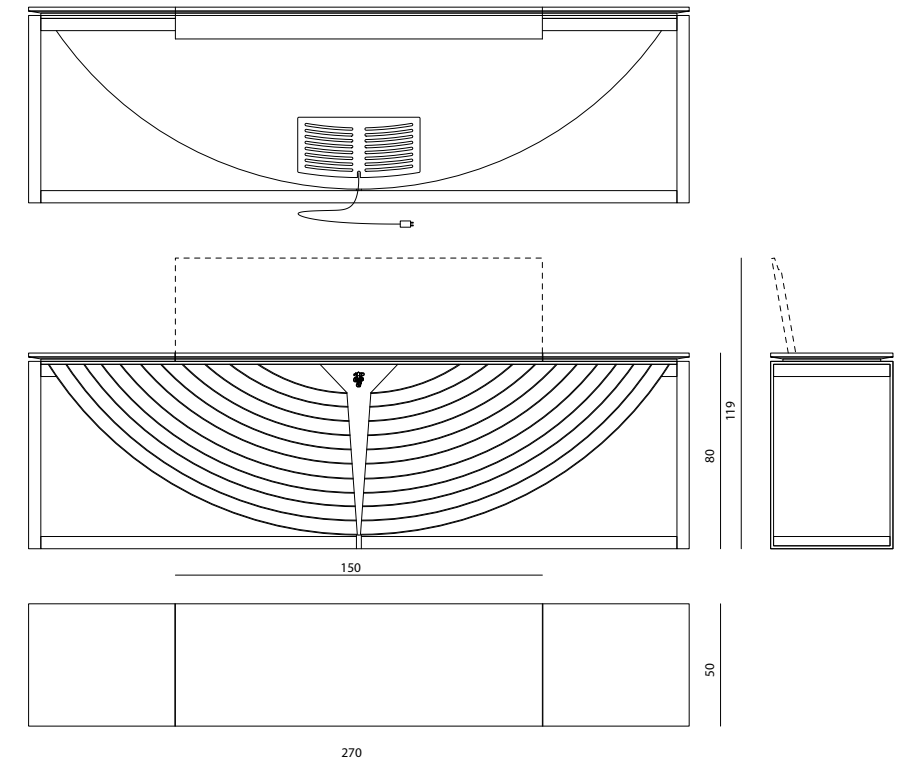



LEONARDO

MOBILE BAR - BAR CABINET

Alessandro La Spada

Mobile alto a due ante con lati curvi, struttura in legno composta da uno zoccolo, un profilo sotto-top e un montante rivestiti in acciaio inox lucido curvato in porzioni concave e convesse. Ante e fianchi scolpiti con lavorazione superficiale canneté in bassorilievo sono disponibili con verniciatura lucida (colori RAL/NCS), oppure in colori metallizzati a campionario, oppure rivestiti in pelle Soft leather. Interni laccati con colori RAL/NCS opaco. I profili decorativi in acciaio inox curvato sono disponibili nella selezione finiture metalliche. Top in appoggio in marmo lucidato con profilo inferiore bisellato. Disponibile su richiesta con illuminazione interna a LED e frigobar da 35 litri.

High unit with two doors with shaped sides; structure in wood with plinth, under-top profile and supporting pillar covered in polished curved stainless steel, with convex and concave shapes. Doors and sides decorated with 'canneté' stripes carved in low relief, available with shiny lacquer (RAL or NCS colours) finish or in metal colours as per finishes selection or upholstered in Soft leather. Interiors in matt RAL/ NCS lacquer. Decorative profiles in curved stainless steel, available in the metal lacquer finish selection. Top in polished marble with bevelled lower edge. Optional: internal LED lights and bar fridge 35 lt.

vedi anche/see also LEONARDO letto-bed, LEONARDO comodino-bedside table, LEONARDO cassetiera-chest of drawers, LEONARDO media-high unit, LEONARDO mobile basso-low unit, LEONARDO consolle portavavabo-wellness unit, LEONARDO libreria-bookshelf, LEONARDO armadio-wardrobe

● click here

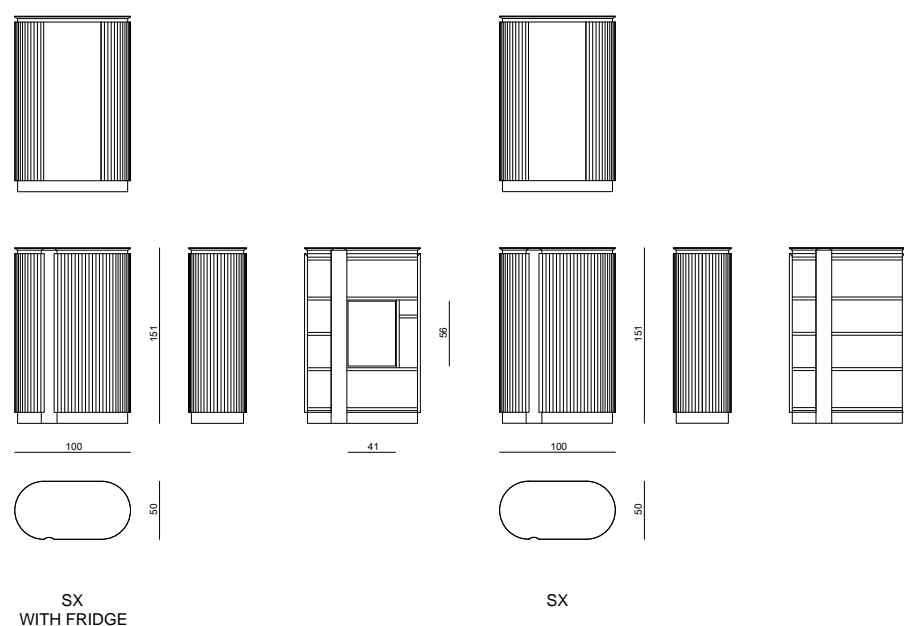

SX
WITH FRIDGE

SX

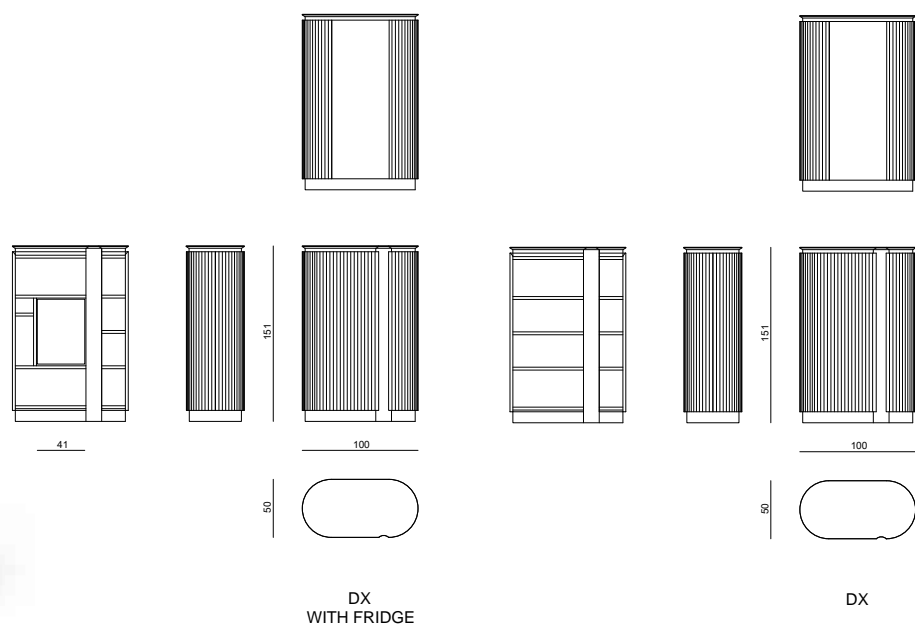

DX
WITH FRIDGE

DX



LISBET

MOBILE BAR - BAR CABINET

Steve Leung

Mobile bar a due ante in legno. Mobile in legno verniciato con effetto nuvolato artistico in tre colori (verde, blu, rosso) o con effetto materico "moon gold", oppure in tinte RAL/NCS lucido. Le ante esterne hanno sagoma scatola, incernierate sul fianco del mobile. basamento in legno massello di frassino scolpito e tinto opaco. Ripiani interni in legno e un cassetto interno. Mensole porta-oggetti sull'interno dell'anta sinistra. Top in marmo di 3 cm di spessore con bordo svasato perimetrale.

Bar cabinet in wood with two doors. Wooden cabinet painted with artistic cloud effect in three colours (green, blue, red) or with 'moon gold' material effect, or in RAL/NCS glossy colours. The outer doors are box-shaped, hinged to the side of the cabinet. Base in solid ash wood, carved and matt stained. Internal glass shelves and an internal drawer. Storage shelves on the inside of the left door. Marble top 3 cm thick with perimeter flared edge.

vedi anche/see also LISBET media-high unit, LISBET mobile basso-low unit

● click here

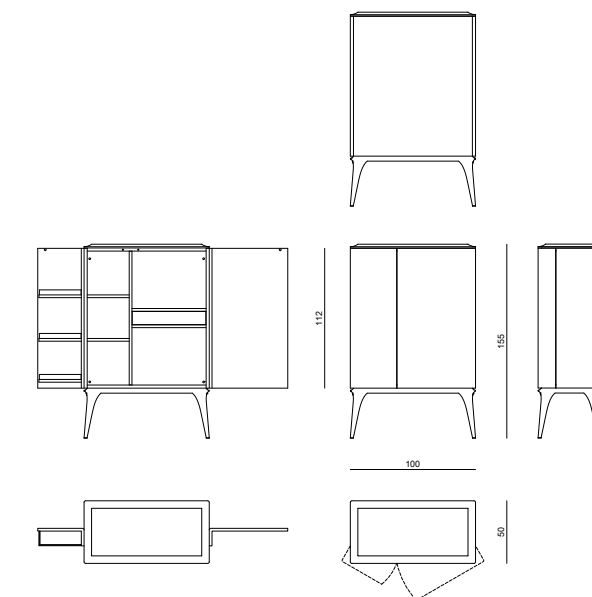



PALAWAN

MOBILE BAR - BAR CABINET

Steve Leung

Mobile in legno laccato lucido a 2 ante in specchio (naturale - bronzo - fumé) curvato e inciso con angolare saldato a UV. Maniglie in alluminio laccato satinato e nappine in pelle (opzionali). Interno con ripiani in legno laccato e cristallo, schienale interno a specchio (naturale - bronzo - fumé), basamento agomato con gambe in faggio laccato lucido. Schienale esterno tamburato di grosso spessore rivestito in pelle o tessuto. Profili di top, base e schienale in acciaio inox lucidato, piedi in acciaio satinato. Le parti in metallo sono disponibili nella selezione finiture metalliche.

Disponibile in versione PALAWAN RADICA con schienale esterno in radica in finitura lucida 100 gloss.

Bar unit in polished lacquered wood with two curved engraved mirror doors (natural - bronzed - smoked) and UV welded angles. Satinized lacquered aluminium handles and leather tassels (optional). Inside shelves in lacquered wood and crystal. Inside back part in mirror (natural - bronzed - smoked), shaped base with legs in lacquered polished beech wood. External back profiles in polished stainless steel and legs in satinized steel. Metal parts can be lacquered in any colour included in the metal finish selection.

Available in PALAWAN RADICA version with external backrest in burr walnut 100 gloss finish.

vedi anche/see also PALAWAN madia, mobile alto-cabinet, low cabinet

● click here



VERSIONE RADICA/ RADICA VERSION

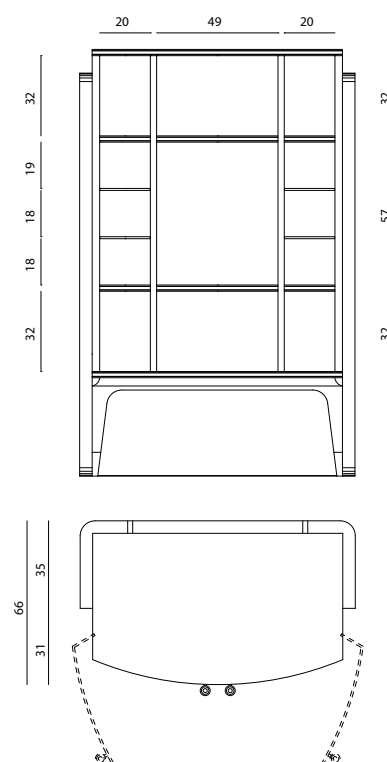
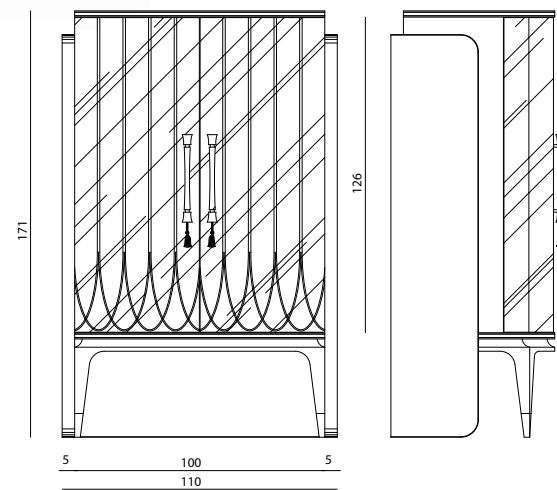

PANAY

MOBILE BAR - BAR CABINET

Steve Leung

Mobile in legno laccato lucido a 2 ante in specchio (naturale - bronzo - fumé) curvato e inciso con angolare saldato a UV. Maniglie in alluminio laccato satinato. Interno con ripiani in legno laccato e cristallo, schienale interno a specchio (naturale - bronzo - fumé), gambe in faggio laccato lucido. Profili di top, base e schienale in acciaio inox lucidato, piedi in acciaio satinato. Le parti in metallo sono disponibili nella selezione finiture metalliche.

Bar unit in polished lacquered wood with two curved engraved mirror doors (natural - bronzed - smoked) and UV welded angles. Satinized lacquered aluminium handles. Inside shelves in lacquered wood and crystal. Inside back part in mirror (natural - bronzed - smoked), legs in lacquered polished beech wood. Metal components can be finished with any lacquer of the metal lacquer finish selection.

vedi anche/see also PANAY madia, mobile alto-cabinet, low cabinet

● click here

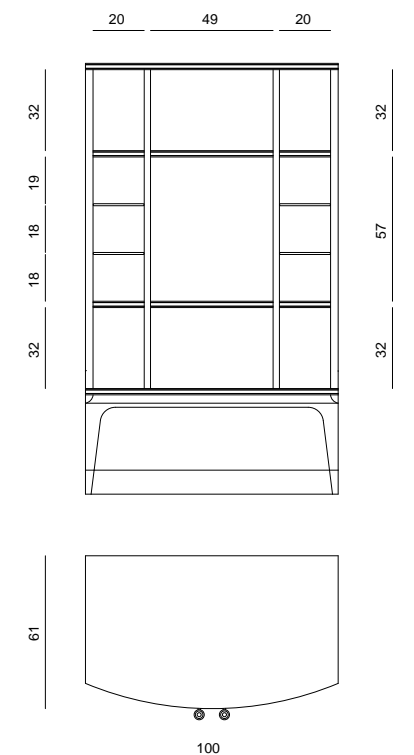
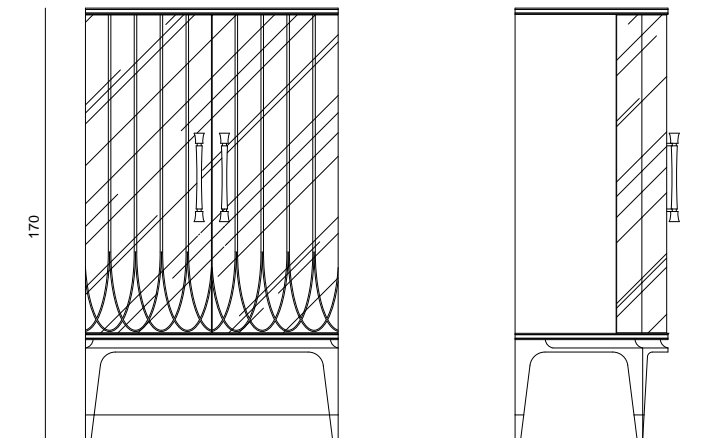



SERENDIPITY

MOBILE BAR - BAR CABINET

Alessandro La Spada

Struttura in multistrati e MDF, vani interni in nobilitato ad alta resistenza, con gole e zoccolo di base in acciaio inox satinato. Rivestimento frontale e laterale in marmo con lavorazione in bassorilievo ed inserti in acciaio inox. Top in marmo con profilo perimetrale in acciaio inox, piano di lavoro in acciaio inox satinato, ante esternamente rivestite in acciaio inox con doppia finitura lucido/satinato con motivo geometrico, pannello interno laccato. Zoccolo in multistrati marino rivestito in acciaio inox satinato. Accessori disponibili su richiesta: lavello in acciaio inox saldato a filo piano di lavoro, rubinetteria in acciaio inox con bocchetta orientabile, frigorifero sottotop. Le parti in metallo, tranne il piano di lavoro e le ante, sono disponibili nella selezione finiture metalliche satinato.

Structure in plywood and MDF, internal compartments in high-resistance ennobled wood, with grooves and base in satinized stainless steel. Front and sides covered in marble with bas-relief engraving and inserts in stainless steel. Top in marble with perimetral profile in stainless steel, working top in satinized stainless steel, doors externally covered in stainless steel with shiny/satinized double finishing and geometric pattern, lacquered internal panel. Plinth in marine plywood covered in satinized stainless steel. Accessories available upon request: sink in satinized stainless steel flush with the worktop, taps in stainless steel with adjustable water outlet, fridge under top. Metal parts available in the satinized metal finishing selection.

[click here](#)

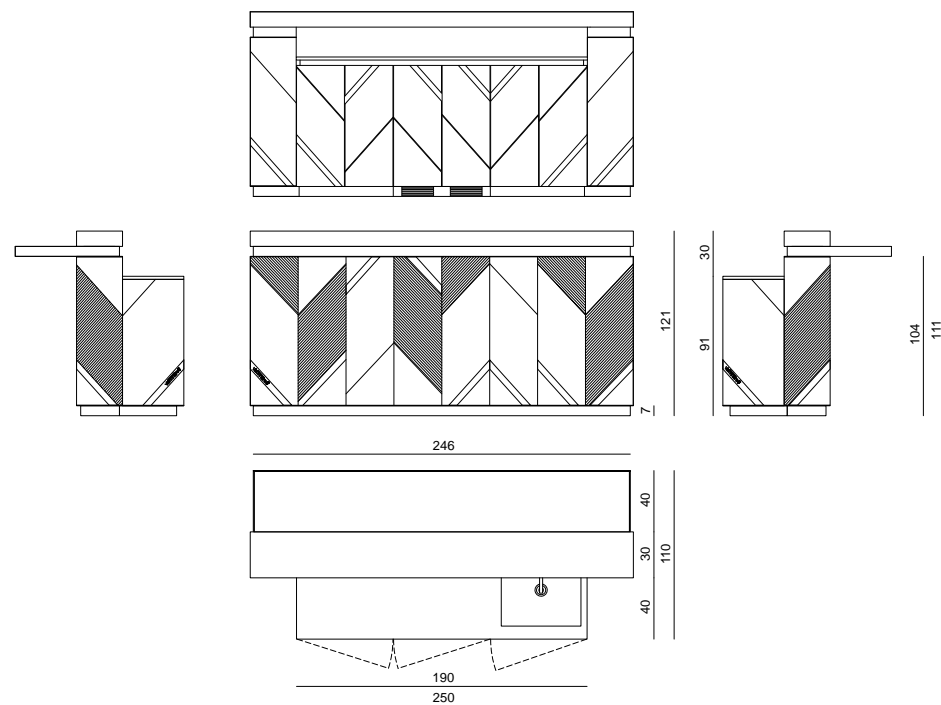



LARIX

PIANOFORTE BAR, PANCHETTA
PIANO BAR, BENCH

Alessandro La Spada - Samuele Mazza

Pianoforte: struttura cassa in MDF con "cover" richiudibile in listellare di pioppo placcato. Rivestimento interno in mosaico a specchio per il bar. Verniciatura finale poliuretana lucida. Leggio ligneo laccato nero lucido con intaglio motivo "gothic". Gambe, spada sostegno "cover" e coronamento inferiore della tastiera in acciaio inox lucido taglio laser. Pomello in alluminio tornito finitura cromo. Tastiera digitale modello Yamaha. Nella struttura sono presenti 3 piccoli vani di servizio.

Panchetta: telaio seduta in legno con imbottitura in poliuretano, tappezzato in pelle o tessuto. Non sfoderabile. Seduta dotata di regolazione d'altezza tramite meccanismo a pantografo. Gambe in acciaio inox lucido taglio laser. Le parti in metallo sono disponibili nella selezione finiture metalliche.

Piano: structure of casing in MDF with opening "cover" in poplar block wood. Internal covering in mirror mosaic for the bar. Final lacquering in gloss polyurethane. Music stand in black gloss lacquer with carved "gothic" design. Legs, sword "cover" support and lower perimeter of keyboard in laser cut polished stainless steel. Pomel in turned aluminium chrome finish. Digital keyboard model Yamaha. In the structure 3 service spaces are available.

Bench: seat frame in wood with padding in polyurethane, covered in leather or fabric. Not removable. Seating may be regulated in height by mechanism. Legs in polished laser cut stainless steel. Metal parts can be lacquered in any colour included in the metal finish selection.

● click here

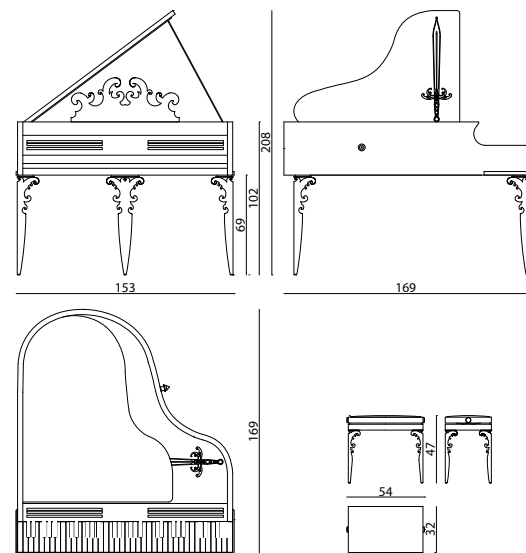

VERSAILLES

BANCONE BAR - BAR CABINET
Alessandro La Spada

Struttura portante in MDF sagomata e curvata con rivestimento capitonne in pelle o tessuto. Top in marmo e sottotop in MDF sagomato e curvato laccato lucido poliester spazzolato. Piano di lavoro in acciaio con lavabo e rubinetteria, mobile dotato di 4 ante rivestite in acciaio con ripiani interni. Frigo inseribile. Gambe composte da elemento principale tronco-cono in cristallo soffiato e molato con lavorazione a bugne, finitura acidata. Elementi torniti e sfera in alluminio e ottone. Zoccolo di base in lamina d'acciaio ad elementi decorativi a "ovale Visionnaire" laccato lucido. Le parti in metallo sono disponibili nella selezione finiture metalliche.

Main structure in shaped and curved MDF with capitonne upholstery in leather or fabric. Top in marble and undertop in shaped and curved MDF, in shiny brushed polyester lacquering. Worktop with stainless sink and faucet with 4 doors covered of steel and internal shelves. Fridge inserted. Legs made of cone-truncated element in blown and grinded crystal, with diamond pattern and with frosted finishing. Turnings and spheres in aluminium and brass. Plinth in steel laminate with Visionnaire oval decorations, polished lacquered. Metal parts can be lacquered in any colour included in the metal finish selection.

vedi anche/see also VERSAILLES tavolo da pranzo dining table, VERSAILLES consolle-console, VERSAILLES cassetiera-chest of drawers

● click here

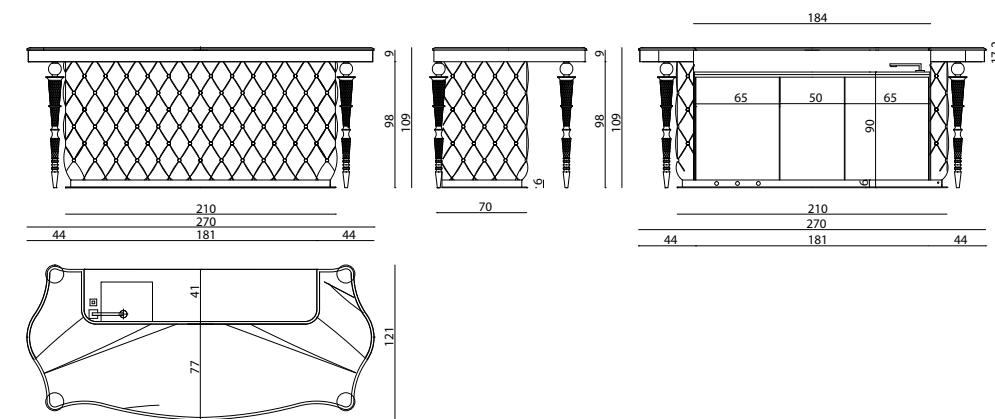

- click on the icons -



AURORA p.320



DANNY p.321



JET PLANE p.322



KINGS CROSS p.323



KOBOL p.324



MARGOT p.325



LAFITTE p.326



OLIMPIA p.328



RAWDON p.329



WESTLEY p.330

ICONICI - *ICONIC*



GRIMILDE p.332



WINDSOR p.333



AURORA

MOBILE TRUCCO - VANITY UNIT

Steve Leung

Struttura in legno impiallacciato o laccato, lucidato 100 gloss (sia esternamente che internamente). Ante ad apertura totale (180°), rivestite in marmo con intarsi e cornice in acciaio inox lucidato. Allestimento interno con specchio di cortesia retroilluminato a led, con sensore di accensione a sfioramento, 4 ripiani, 4 cassetti e mensole porta oggetti all'interno delle ante. Gambe in fusione di alluminio lucidata a specchio con puntali in alluminio satinato, o finitura lacca oro o bronzo o nickel nero.

Lacquered or veneered wood structure, polished in 100 gloss (inside and outside). Doors with full opening system (180°), inlaid marble covering and frame structure in stainless polished steel. Internally equipped with courtesy led backlight mirror, touch sensor system, four shelves, four drawers and storage shelves in the doors. Legs in mirror-polished aluminium cast with tips in satinized aluminium or in bronzed, golden or black nickel finishing.

vedi anche/see also AURORA consolle-console, AURORA media-high unit, AURORA mobile bar-bar cabinet

● [click here](#)

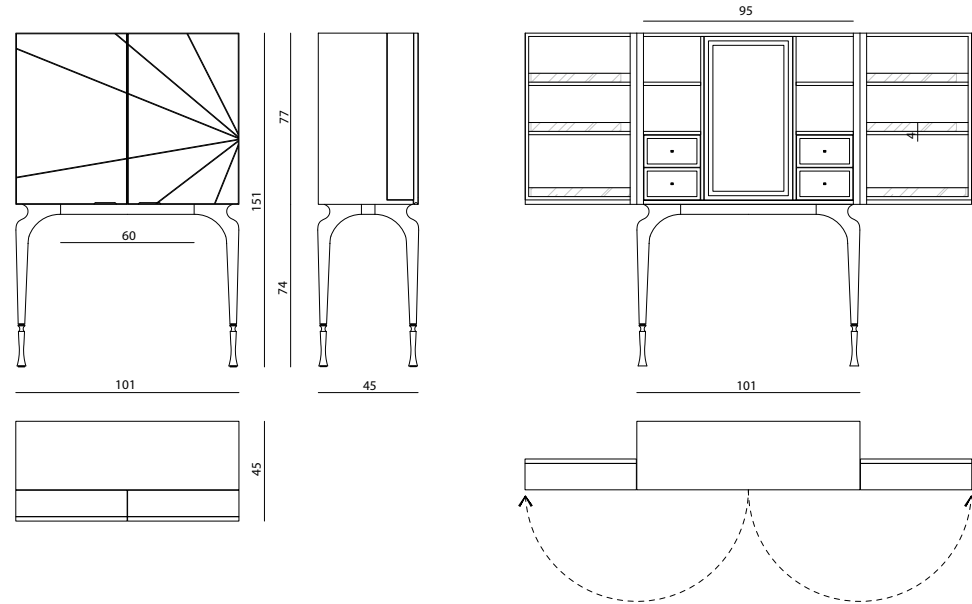

DANNY

MOBILE TRUCCO - VANITY UNIT

Mauro Lipparini

Mobile trucco con 2 cassetti e vano make-up con ribalta dotata di specchio e chiusura smorzata, piano di lavoro in legno laccato lucido, scocca del mobile in legno con lato esterno laccato lucido e superficie interna rivestita in acciaio satinato. Top e cassetti sono rivestiti in pelle o tessuto. Interno cassetti laccato opaco. Top e cassetti sono disponibili nelle finiture selezione essenze, le parti in metallo sono disponibili nella selezione finiture metalliche.

Make-up desk with 2 drawers. Make-up unit including a openable top element equipped with mirror and damped closing system; worktop in glossy lacquered wood; main structure in wood with external side with polished finishings and internal part in satinized steel. Top and drawers upholstered in leather or fabric. Internal part of drawers finished in matt lacquering. Top and drawers available with veneer selection finishings; metal parts can be lacquered in any colour included in the metal finish selection.

vedi anche/see also DANNY mobile basso-low cabinet, DANNY cassettiera-chest of drawers

● [click here](#)

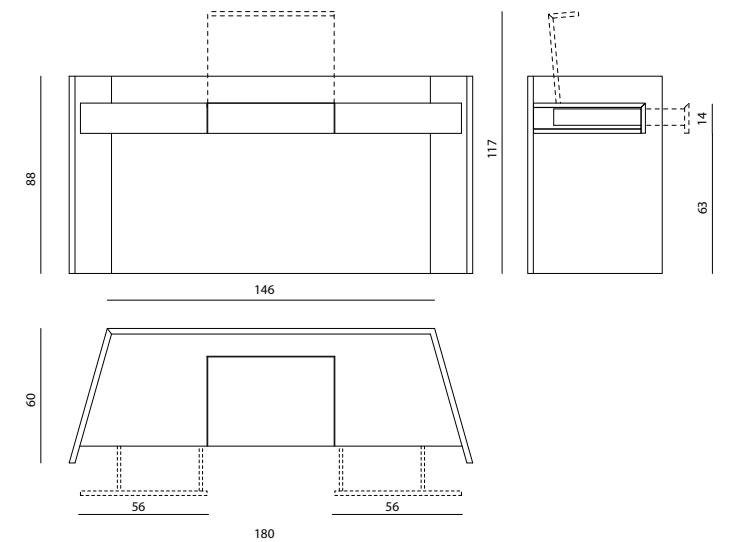



JET PLANE

MOBILE TRUCCO E SPECCHIERA A PARETE
MAKE-UP UNIT AND WALL MIRROR

Steve Leung

Struttura in legno sagomato a ultrasuoni, laccata lucida (tinte RAL/NCS) completa di due cassetti a scomparti con maniglie in pelle e ottone disponibili nella selezione finiture metalliche lucide. Top in pelle. Rivestimento interno dei cassetti in microfibra. Mobile predisposto per attacco a parete obbligatorio. Abbinabile su richiesta alla specchiera tonda Jet Plane.

Specchiera tonda da parete in legno, con illuminazione di cortesia a LED su richiesta. Abbinabile su richiesta al mobile trucco Jet Plane.

Structure in wood shaped by means of ultrasounds, with polish lacquered finish (Ral/NCS colour), equipped with tow drawers with internal compartments and handles in leather and brass. Metal parts can be lacquered in any colour included in the metal finish selection. Top in leather. Drawers internally covered in microfiber. Make-up desk to be wall mounted. Upon request, it can be combined with round Jet Plane mirror.

Round wall mirror in wood which can be equipped LED light upon request. It can be combined with Jet Plane make-up desk

vedi anche/see also JET PLANE scrivania-writing desk

● click here

MAKE-UP UNIT & WALL MIRROR

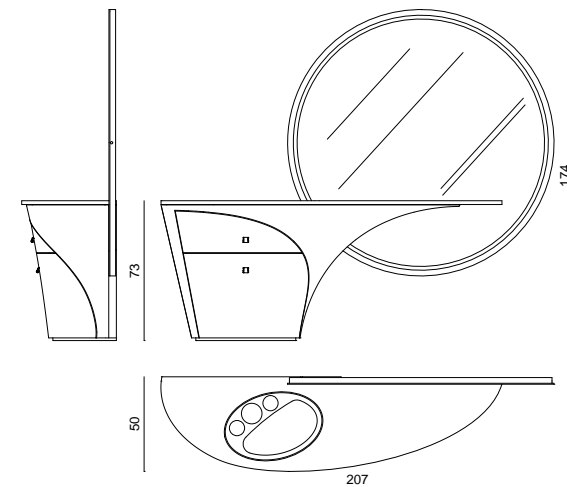

MAKE-UP UNIT

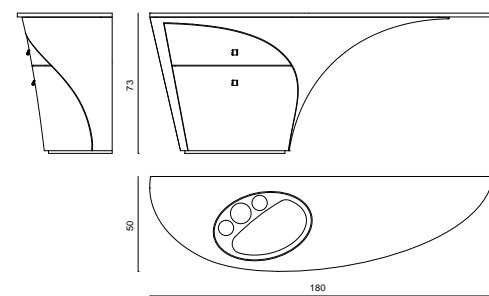

WALL MIRROR

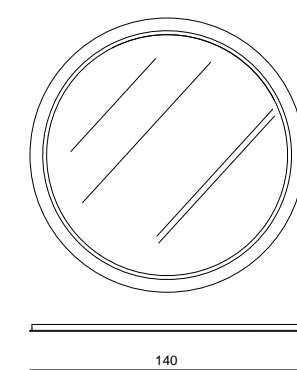

KINGS CROSS

MOBILE TRUCCO - VANITY UNIT

Mauro Lipparini

Mobile trucco a due ante, struttura esterna portante in legno massello di noce canaletto con finitura naturale a poro aperto, scolpito con sezione sagomata a tre lobi. Struttura esterna in finitura verniciata RAL/NCS lucido oppure metallizzati. Interno in legno laccato con tre specchiere, una piccola cassetteria di servizio rivestita in pelle con vassoi estraibili, quattro mensole in metallo rivestite in pelle ed un ripiano inferiore a scomparsa. Retroilluminazione della specchiera a LED a luce diffusa.

Make-up desk with two doors, supporting frame in Canaletto walnut solid wood with open-pore natural finish and shaped three-lobes section. Internal structure in lacquered wood equipped with three mirrors, one small chest of drawers upholstered in leather with pull-out trays, four metal shelves upholstered in leather and a lower retractable shelf. Mirror with LED backlight diffuser.

vedi anche/see also KINGS CROSS pouf-pouffe, KINGS CROSS tavolino tondo-round low table, KINGS CROSS tavolo basso-low table, KINGS CROSS consolle-console, KINGS CROSS mobile basso-low cabinet, KINGS CROSS cassetteria-chest of drawers

● click here

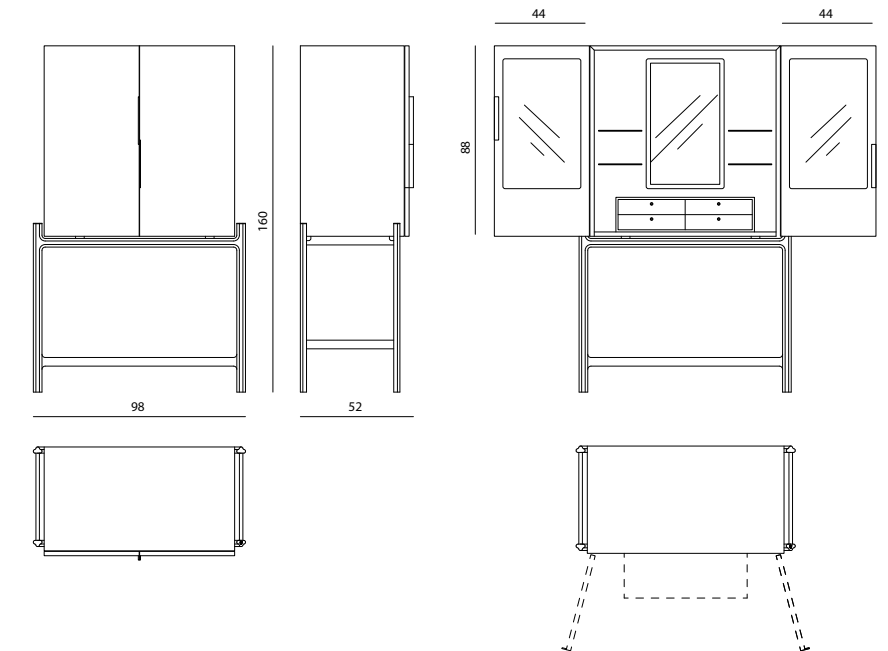



KOBOL

MOBILE TRUCCO - MAKE-UP UNIT
Alessandro La Spada

Mobile trucco a due cassetti in legno laccato (tinte RAL/NCS), provvisto di alzata laterale e posteriore in legno scolpito in bassorilievo con lavorazione "canneté", internamente rivestita in acciaio inox satinato. Top in marmo. Sul fondo del top sono presenti due sportelli "segreti" e uno specchio con fascia luminosa a LED. Struttura portante in metallo cromato. Le parti in metallo sono disponibili nella selezione finiture metalliche.

Make-up desk with two drawers in lacquered wood (RAL/NCS colours), equipped with lateral and back high panels in wood with bas-relief canneté decoration, internally covered in satin stainless steel. Top in marble equipped with two secret compartments and a mirror with LED lights. Main structure in chromed metal. Metal parts can be lacquered in any colour of the polish metal finish selection.

vedi anche/see also KOBOL mobile portlavabo - console with basin

[click here](#)

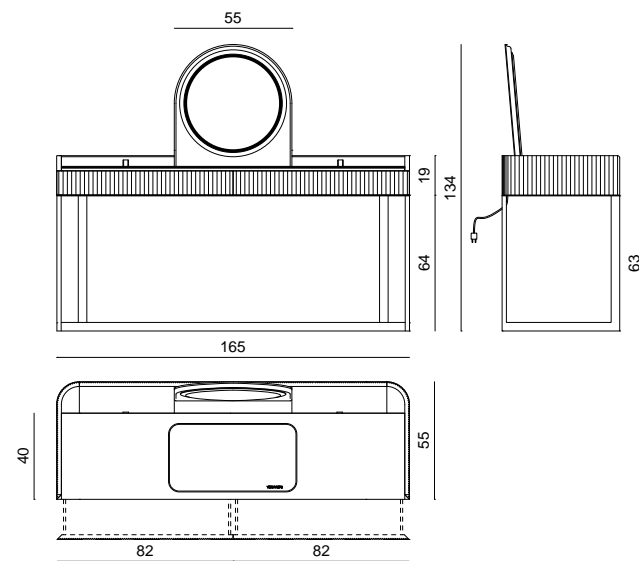

MARGOT

SECRETAIRE - MAKE-UP DESK
La Conca

Struttura in compensato multistrati tamburato con pannellature in MDF. Piano centrale con apertura a compasso fornito di specchio interno con bordo bisellato. I due cassetti sono montati su guide integrate, per una chiusura assistita. Interno cassetti e vano centrale, finitura laccata opaca. La struttura è completamente rivestita in tessuto o pelle.

Structure in honeycomb plywood with panels in MDF. Central top with compass opening, provided with an internal mirror with bevelled border. The two drawers are assembled on an integrated runners, for a guided closing. Internal drawers and central compartment in mat lacquered finishing. The structure is completely upholstered with fabric or leather.

[click here](#)

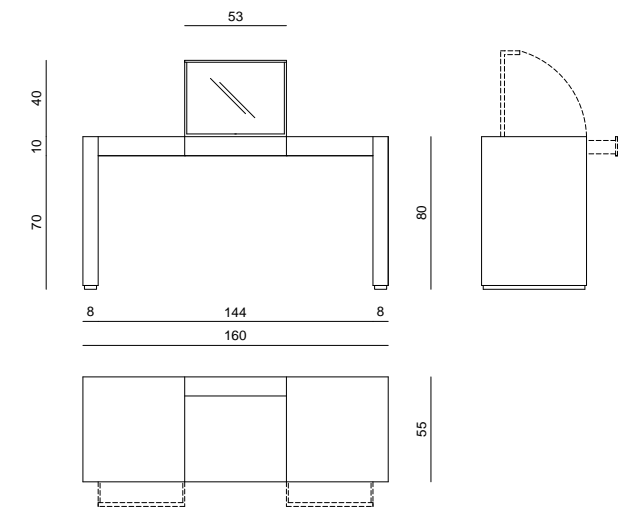



LAFITTE

MOBILE TRUCCO - VANITY UNIT

Alessandro La Spada

Struttura principale in tubolare d'acciaio. Rivestimento interno a pannelli di multistrati, imbottiti e rivestiti in tessuto o pelle. Rivestimento esterno dei fianchi in pelle o tessuto con motivo geometrico a pannelli rivestiti singolarmente, con inserti decorativi in acciaio satinato e logo inciso. Top a incasso in marmo provvisto di 3 cassetti rivestiti frontalmente ed internamente laccati. Specchiera superiore con profilatura perimetrale in acciaio; riquadro e stemma araldico Visionnaire satinati con retroilluminazione a LED. Le parti in metallo sono disponibili nella selezione finiture metalliche.

Disponibile con fianchi trapuntati e rivestiti a motivo "Ripley", "Ultrasound" oppure "Perkins".

Main structure in steel solid pipe. Internal coating in plywood panels, padded and upholstered in leather or fabric. External upholstery of sides in leather or fabric decorated with individually upholstered panels creating a geometric pattern, with decorative inserts in satinized steel and engraved logo. Built-in marble top equipped with 3 frontally upholstered drawers, inside lacquered. Upper mirror with perimeter profile in steel; satinized frame and Visionnaire coat of arms with LED backlighting system. Metal parts can be lacquered in any colour included in the metal finish selection.

Available with quilted sides upholstered in 'Ripley', 'Ultrasound' or 'Perkins' motifs.

[click here](#)



VERSIONE PERKINS
PERKINS VERSION



VERSIONE RIPLEY INTRECCIATO
INTERWOVEN RIPLEY VERSION



VERSIONE RIPLEY TRAPUNATO
QUILTED RIPLEY VERSION

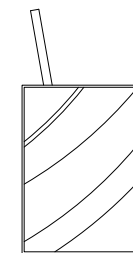
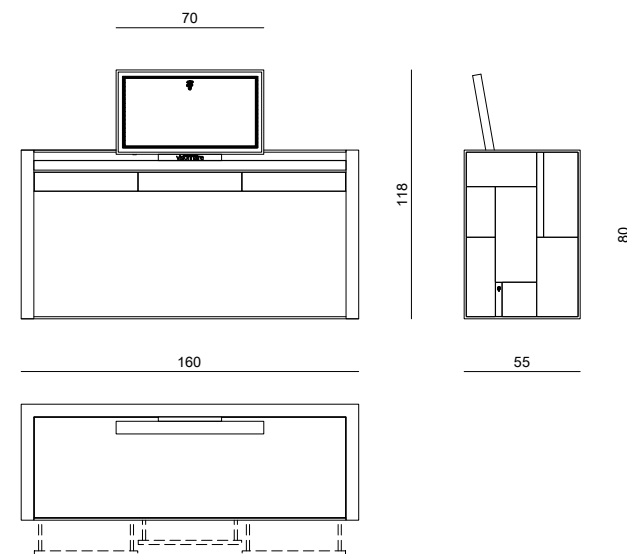

VERSIONE ULTRASOUND
ULTRASOUND VERSION

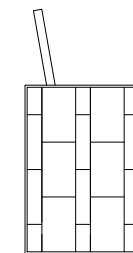

VERSIONE PERKINS
PERKINS VERSION

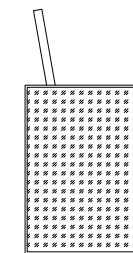

VERSIONE RIPLEY INTRECCIATO
INTERWOVEN RIPLEY VERSION

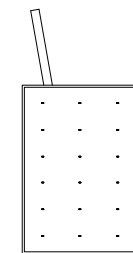

VERSIONE RIPLEY TRAPUNATO
QUILTED RIPLEY VERSION



OLIMPIA

MOBILE TRUCCO - MAKE-UP UNIT

Alessandro La Spada

Mobile trucco a tre cassetti, scocca in legno laccata lucida. La cornice interna dei fianchi e del top è rivestita in acciaio inox lucido curvato. Frontali dei cassetti rivestiti in pelle o tessuto, interno opaco. Pad sottomano in pelle. Specchio integrato con cornice in acciaio inox e bordo retroilluminato a LED. Le parti in acciaio sono disponibili nella selezione finiture metalliche lucide.

Make-up desk with three drawers, external structure in polish lacquered wood. Internal frame of sides and top covered in curved polish stainless steel. Drawer fronts upholstered in leather or fabric, internally mat lacquered. Pad in leather. Integrated mirror with stainless steel frame and perimeter backlit with LED lights. Steel parts available with any finish included in the polished metal finish selection.

● [click here](#)

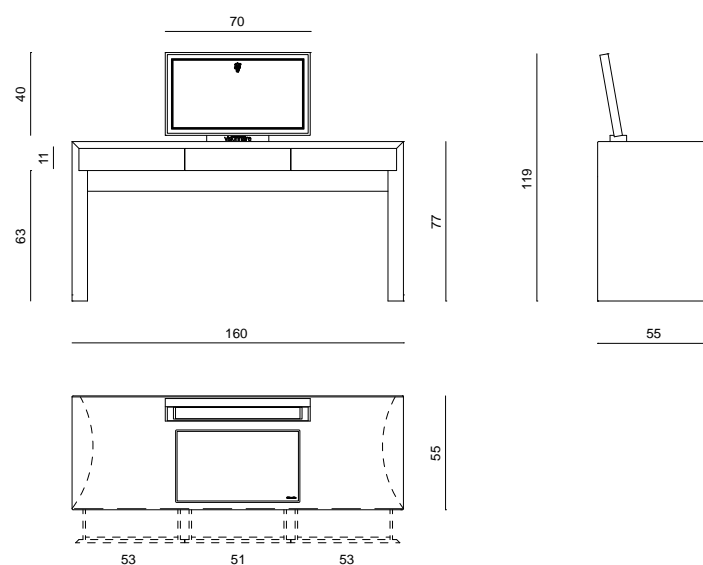

RAWDON

MOBILE TRUCCO - MAKE-UP CABINET

La Conca

Struttura in multistrati e MDF rivestita interamente in pelle, interno cassetto laccato opaco a colori RAL, cornice perimetrale frontale incassata rivestita in specchio (naturale/bronzo/fumé). Retro del mobile laccato opaco, cornici frontali in acciaio inox satinato con logo Visionnaire inciso. Sottomano in legno laccato o rivestito in essenza con finitura lucida. Specchiera superiore con profilatura perimetrale in acciaio inox satinato, specchio con bordo retroilluminato a LED, diponibile con retro laccato opaco oppure rivestito in pelle. Le parti in acciaio sono disponibili nella selezione finiture metalliche satinato. Il sottomano è disponibile nelle finiture selezione essenze.

Structure in plywood and MDF fully covered in leather, internal drawer in mat lacquer (RAL colours), front built-in perimetral frame in mirror (natural/bronze/smoked). Rear back in mat lacquer, front frames in satinized stainless steel with laser Visionnaire logo. Desk pad in lacquered wood or veneered with shiny finishing. Upper mirror with perimetral profile in satinized stainless steel, mirror with back-lightened LED edge, available with rear part in mat lacquer or covered in leather. Metal parts available in the satinized metal finishing selection. The desk pad is available in the veneer finishing selection.

vedi anche/see also RAWDON mobile basso-low cabinet, RAWDON cassetiera-chest of drawers

● [click here](#)

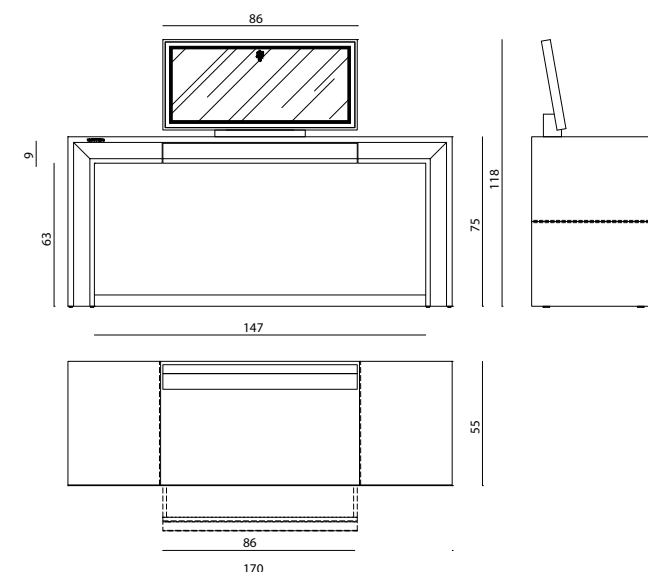



WESTLEY

MOBILE TRUCCO - MAKE-UP UNIT

Steve Leung

Mobile trucco costituito da una cassettera e top in cristallo da 12 mm. Struttura in legno multistrati e MDF con frontali cassetti rivestiti in essenza e interni laccati (colori RAL). Top e fianco esterno della cassettera rivestiti in pelle intrecciata con bordi lisci. Zoccolo e bordature cassetti in acciaio inox satinato. Top in vetro temperato (extra chiaro/bronzo/fumé), gamba in legno rivestita in pelle con puntalini in acciaio inox satinato. I frontali dei cassetti ed il rivestimento lato interno sono disponibili nelle finiture selezione essenze. Le parti in metallo sono disponibili nella selezione finiture metalliche satinato.

Disponibile in versione WESTLEY RADICA con scocca esterna della cassettera e frontali cassetti in radica in finitura lucida 100 gloss.

In abbinamento a specchiera luminosa WESTLEY.

Vanity unit with drawer unit and top in crystal 12 mm. Structure in plywood and MDF with front drawers covered in veneer and lacquered internal parts (RAL colours). Top and external side of the drawer unit covered with woven leather with smooth edges. Plinth and drawers borders in satinized stainless steel. Top in tempered glass (extra clear/bronze/smoked), wooden leg covered in leather with tips in satinized stainless steel. The available finishes for the front drawers and the internal side are included in the veneer selection finishings. Metal parts available in the satinized metal finishing selection.

Available in WESTLEY RADICA version with external drawer shell and drawer fronts in burr walnut in 100 gloss finish.

In combination with WESTLEY mirror with lighting.

vedi anche/see also WESTLEY specchiera-mirror

● [click here](#)

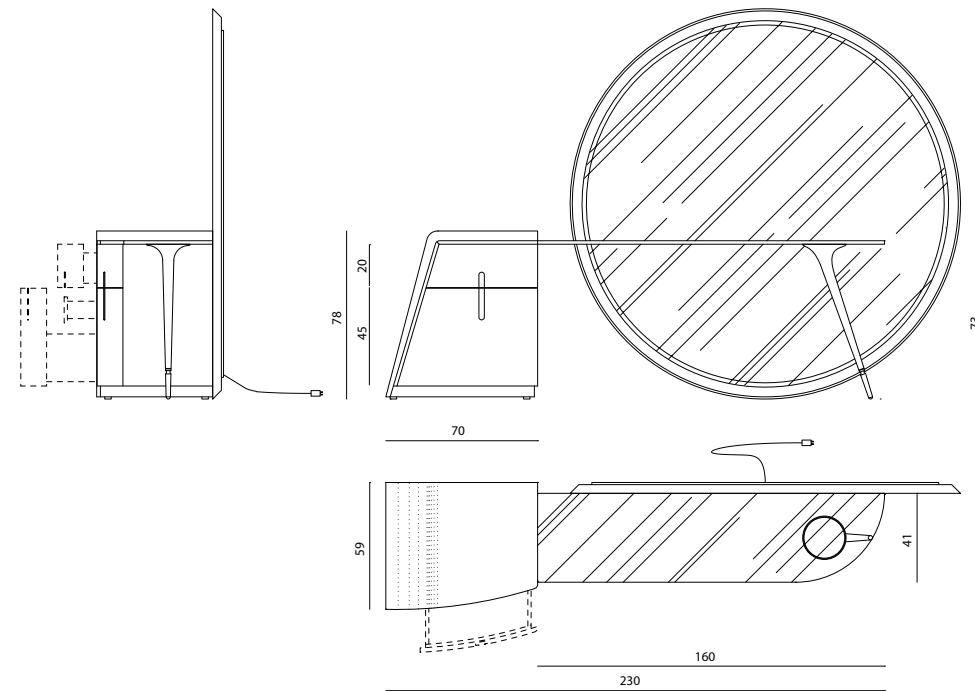

VERSIONE RADICA/ RADICA VERSION



GRIMILDE

MOBILE TRUCCO - VANITY UNIT
Alessandro La Spada

Struttura in MDF finitura laccata lucida, provvisto di 3 cassetti frontali in legno laccato curvato, finitura interna laccata opaca. Top in marmo bisellato sagomato. Specchio ovale illuminato a LED con struttura in ottone cromato, tornerie in alluminio. Gambe in coni sagomati in ottone laccato con tornerie in alluminio, e decorazione a ovali in acciaio inox lucido. Le parti in metallo sono disponibili nella selezione finiture metalliche.

Top disponibile in marmo: Silverwave, Frappuccino.

Structure in shiny lacquered MDF, provided with 3 front drawers in curved lacquered wood, mat lacquered internal finishing. Top in shaped bevelled marble. Oval mirror with LED lighting in chromed brass, turnings in aluminium. Legs made of shaped cones in lacquered brass with aluminium turnings, and decoration with ovals in shiny stainless steel. Metal parts can be lacquered in any colour included in the metal finish selection.

Top available in marble: Silverwave, Frappuccino.

vedi anche/see also GRIMILDE poltrona-armchair, GRIMILDE wellness room

● click here

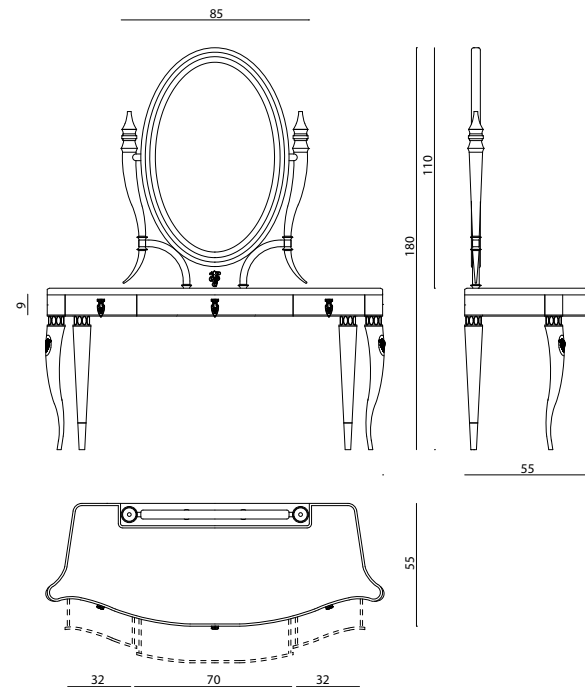

WINDSOR

MOBILE TRUCCO - MAKE-UP UNIT
Alessandro La Spada

Consolle con trittico di specchi e 3 cassetti sottopiano. Struttura mista in legno massello tulipie e MDF laccato lucido 100 gloss, con decori a rilievo. Decorazioni metalliche in ottone cromato, bracciali decorativi sui piedi in alluminio e acciaio laserato cromato. Guide cassetti bilanciate con rientro smorzato. Specchi retroilluminati a led a luce calda, con i due laterali orientabili con cerniere in ottone. Loghi araldici sotto lacca trasparente. Opzione: laccatura madreperla. Le parti in metallo sono disponibili nella selezione finiture metalliche.

Console with 3 mirrors and 3 drawers under the top. Structure made of mixture of solid tulipie wood and glossy 100 lacquered MDF, with decorations in relief. Metallic chromed brass decorations and studs. Decorative rings over the feet made of aluminium and chromed laser cut steel. Drawer's rail balanced through a dampened return system. Backlit mirrors with warm light LEDs. Both the lateral mirrors are swivelling with brass joints. Visionnaire coat of arms under transparent lacquer. Option: mother of pearl lacquer. Metal parts can be lacquered in any colour included in the metal finish selection.

vedi anche/see also WINDSOR tavolo da pranzo-dining table, WINDSOR cassettiera-chest of drawers for desk, WINDSOR scrittoio con cassetti-desk with drawers, WINDSOR vetrinetta-showcase, WINDSOR parete modulare-modular elements, WINDSOR armadio-wardrobe, WINDSOR specchio-mirror, WINDSOR vaso-vase, WINDSOR wellness room

● click here

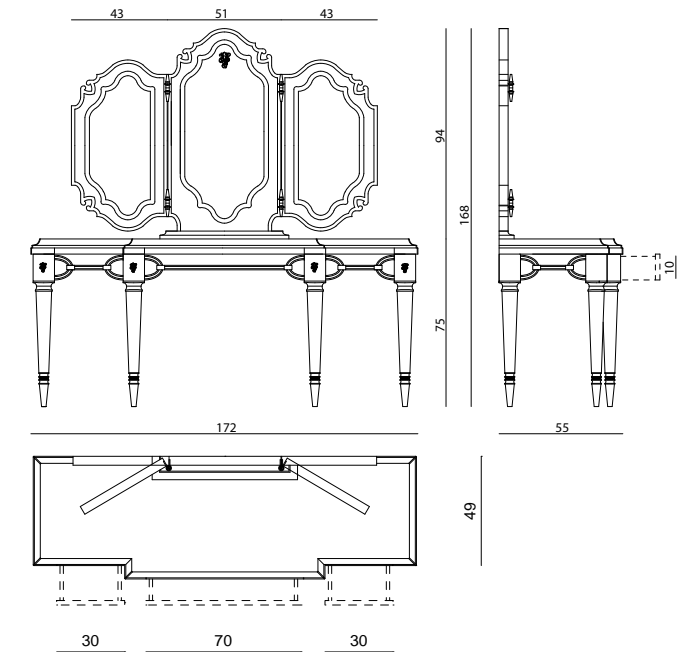

- click on the icons -



AMBASSADOR p.336



DANTE p.337



HARPO p.338



JET PLANE p.339



SANYA p.340



WALL STREET p.341



WILSHIRE p.342



WRIGHT p.343

ICONICI - *ICONIC*



WINDSOR p.344



AMBASSADOR

SCRIVANIA - WRITING DESK

La Conca

Scrivania in legno laccato e pelle. Scocca in multistrati e MDF laccato lucido, top curvato e sagomato laccato lucido (colori RAL), con bordo ad alto spessore e bordo in pelle. Sottomano in pelle con fondo in salpa e velluto, con logo ricamato. Gamba laterale in legno rivestito in pelle e passacavo interno per il passaggio di cavi e cablaggi. Cassettiera integrata con pannelli rivestiti in pelle. Zoccolo di appoggio e profili decorativi in acciaio inox satinato. Le parti metalliche sono disponibili nella selezione finiture metalliche satiniate.

Writing desk in lacquered wood and leather. External structure in plywood and MDF with polished lacquer, curved and shaped top with polished lacquer (RAL colours) with thick edge and leather profile. Pad in leather with bottom in salpa bonded leather and velvet and decorated with embroidered logo. Side leg in wood upholstered in leather and internal cable passage for wiring and cables. Intergated chest of drawers with panels covered in leather. Plinth and decorative profiles in satin stainless steel. Metal parts available with satin metal lacquered finish.

● click here

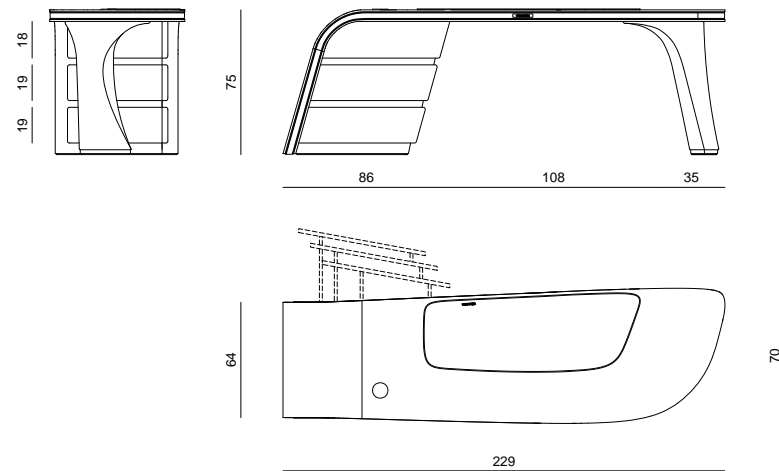

DANTE

SCRIVANIA - WRITING DESK

Alessandro La Spada

Scrivania in legno e acciaio. Top e fianchi in legno rivestito in essenza o radica di noce (selezione essenze a campionario) oppure laccata in tinte RAL/NCS con finitura poliesteri spazzolato 100 gloss. Un cassetto ricavato nello spessore del top, con frontalino in legno in tinta. Interni laccati opaco. Struttura portante in metallo a traliccio rivestito con lamine in acciaio inox calandrato disponibili nella selezione finiture metalliche. In opzione disponibile pad sottomano in pelle.

Writing desk in leather and steel. Top and sides in wood covered with veneered wood or walnut root (colours as per veneer selection) or lacquered in RAL/NCS colours with 100 gloss polyester finish. 1 drawer set in the thickness of the top with front in matching wood. Interiors in mat lacquered finish. Main structure in metal covered with curved stainless steel, available in the metal finish selection. Optional leather hand pad available.

vedi anche/see also DANTE cassettiera-chest of drawers

● click here

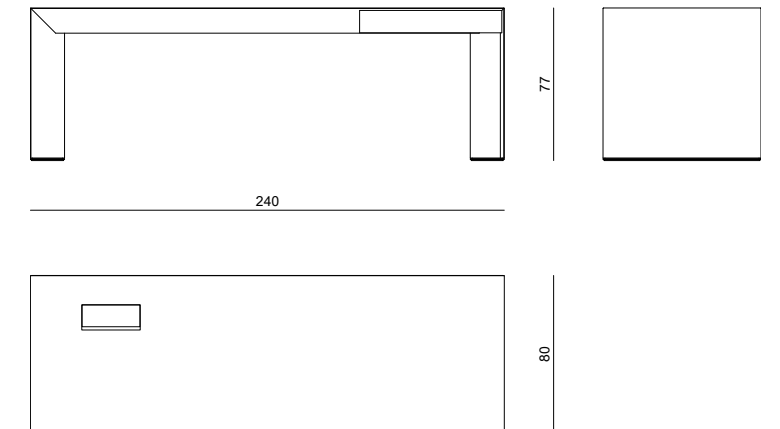



HARPO

MOBILE RECEPTION - RECEPTION DESK
Alessandro La Spada

Mobile reception in legno e vetro, superficie esterna rivestita in legno scanalato in finitura opaca abbinato a porzioni in vetro satinato stratificato con lamina stampata a motivi floreali. Finitura interna laccata opaca, con luci a LED di cortesia e predisposizione per passacavi sotto pavimento.

Reception desk in wood and glass, external surface covered in ribbed wood in mat finish combined with satin stratified glass portions with floral-printed lamina. Mat lacquered internal finish, with courtesy LED lights and predisposition for cable guides under floor.

● [click here](#)

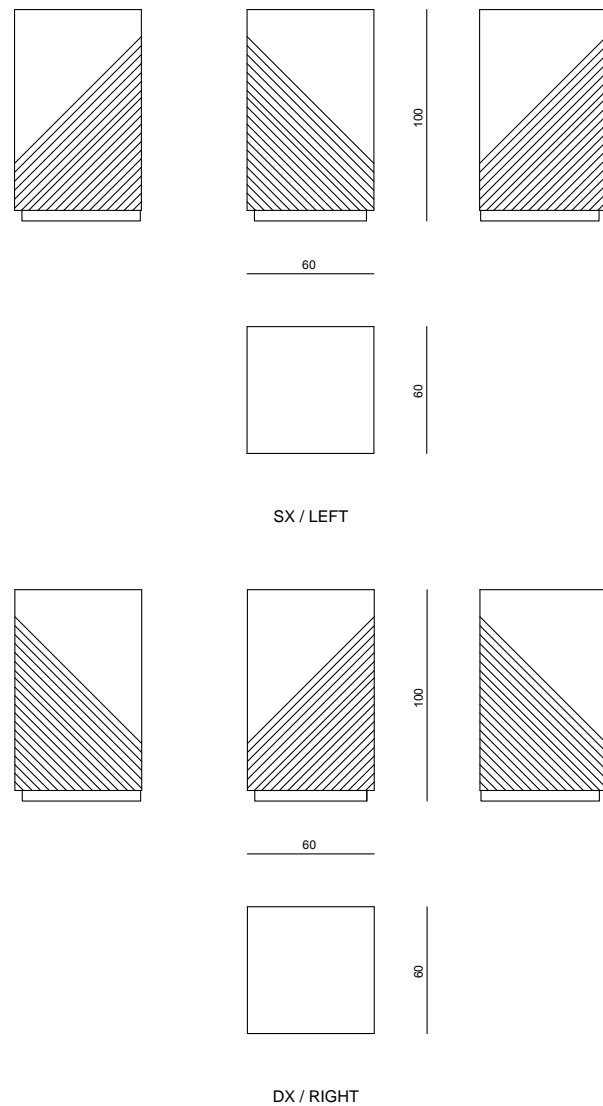

JET PLANE

SCRIVANIA - WRITING DESK
Steve Leung

Scrivania tappezzata in pelle con top in marmo. Struttura portante in legno sagomato interamente rivestita in pelle, con porzioni lisce e trapuntate con ricamo a losanghe, completa di due cassetti con maniglie in pelle e ottone e vano passacavi di servizio. Gamba opposta in legno curvato rivestito in pelle internamente ed in acciaio inox satinato curvato sull'esterno. Top in marmo a forma ovale bisellato e lucidato con passacavi, oppure in legno laccato (colori RAL/NCS). Le parti in metallo sono disponibili nella selezione finiture metalliche.

Disponibile in versione JET PLANE RADICA con cassettera in radica con finitura lucida 100 gloss e sotto-top con ricamo a losanghe, con top coordinato in radica oppure in marmo.

Writing desk upholstered in leather with marble top. Main structure in shaped wood internally upholstered in leather, alternating plain and lozenge quilted sections; desk equipped with two drawers with handles in leather and brass and cable guide. Supporting leg in shaped wood, internally upholstered in leather and externally covered in curved stainless steel with satin finish. Oval top in bevelled and polished marble, or in lacquered wood (RAL/NCS colours), with integrated cable guide. Metal parts can be finished with any lacquer of the metal lacquer finish selection.

Available in JET PLANE RADICA version with burr walnut drawers with 100 gloss finish and under-top with lozenge embroidery, with matching top in burr walnut or marble.

vedi anche/see also JET PLANE mobile trucco e specchiera a parete-make-up unit and wall mirror

● [click here](#)



VERSIONE RADICA/ RADICA VERSION

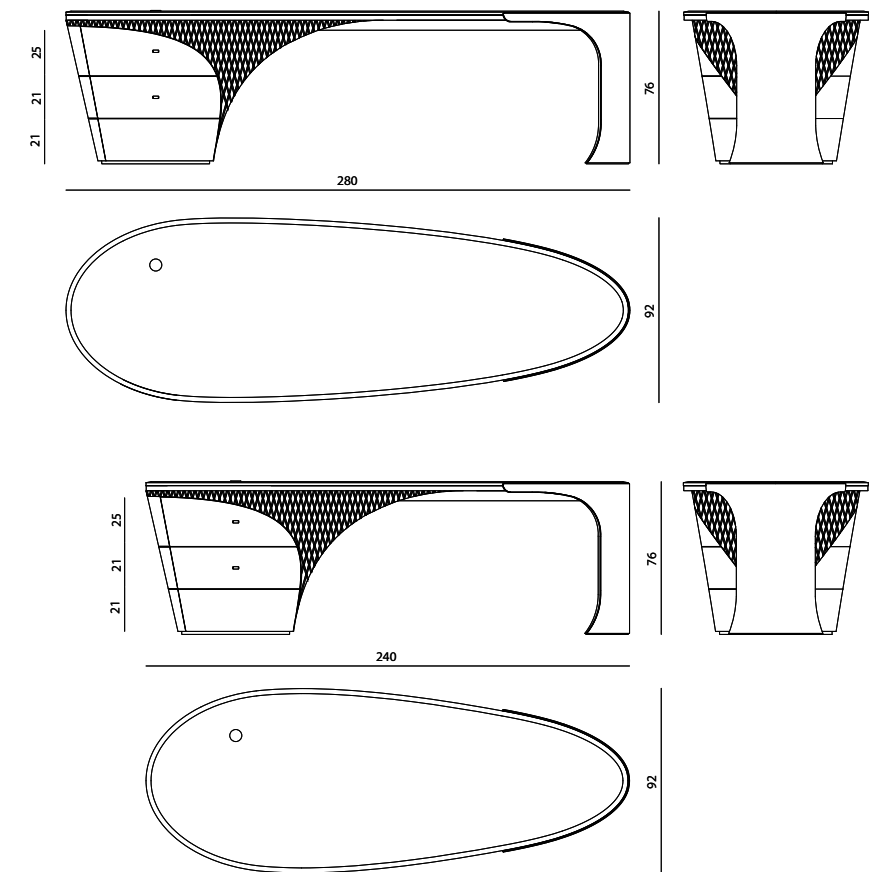



SANYA

SCRIVANIA - WRITING DESK

Steve Leung

Struttura portante in legno con quattro gambe sagomate e conifate applicate a una struttura sottotop ospitante due cassetti con tiretto in ottone satinato. Top conformato ad arco in legno laccato lucido con inserto centrale in marmo alleggerito. Piedi in alluminio tornito satinato. I cassetti sono disponibili nelle finiture selezione essenze; le parti in metallo sono disponibili nella selezione finiture metalliche.

Wooden writing desk with 4 shaped and tapered legs joined to an undertop structure, which includes 2 drawers with knobs in satinized brass. Arc-shaped wooden top in glossy lacquered finishing with central part in lightened marble. Feet in satinized turned aluminium. Drawers available with veneer selection finishings, metal parts can be lacquered in any colour included in the metal finish selection.

● click here

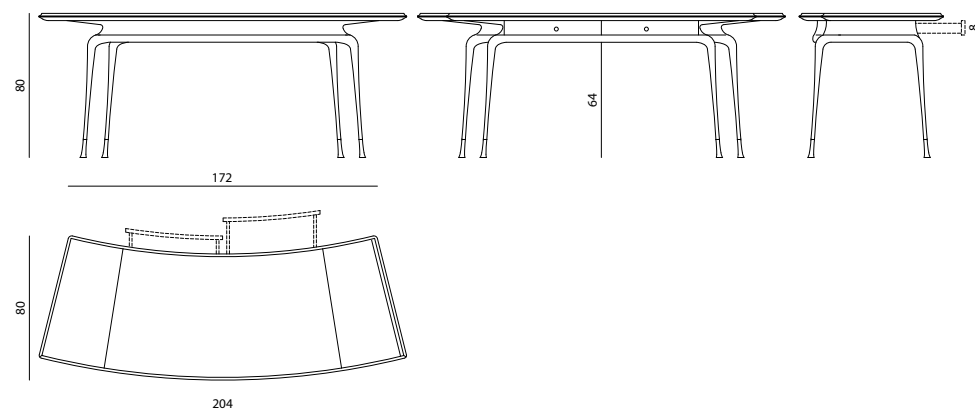

WALL STREET

SCRIVANIA - WRITING DESK

Roberto Lazzeroni

Scrivania con due cassetti. Struttura in legno curvato laccato nei colori RAL/NCS, con finitura manuale lucida 100 gloss. Le superfici esterne dei top e dei ripiani sono rivestite in cuoio. Le superfici verticali (curve e piane) sono rivestite in pelle con cuciture a vista.

Mobile contenitore a cassetti. Struttura in legno con fianchi curvati laccata nei colori RAL/NCS, con finitura manuale lucida 100 gloss. Le superfici esterne dei top e dei cassetti sono rivestite in pelle con cuciture a vista. La parte interna dei cassetti e delle ante è rivestita in microfibra. Illuminazione interna a LED con accensione automatica.

Writing desk with two drawers. Structure in curved wood lacquered with RAL/NCS colours, with 100 gloss hand-polished finish. Top and shelves externally upholstered in 'cuoio' leather. Vertical surfaces (both curved and flat) are upholstered in leather with visible seams.

Cabinet with drawers. Structure in wood with curved sides lacquered with RAL/NCS colours, with 100 gloss hand-polished finish. Top and drawers externally upholstered in leather with visible seams. Drawers and doors internally covered in microfibre. Internally equipped with self-activating LED lights.

vedi anche/see also WALL STREET mobile alto-cabinet

● click here

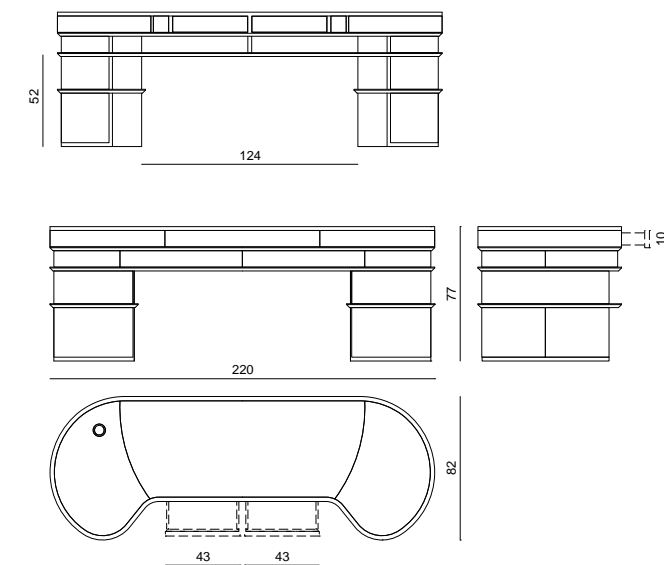
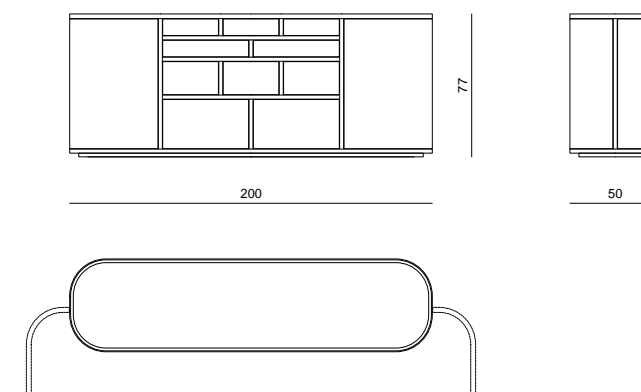



WILSHIRE

SCRIVANIA - WRITING DESK

Steve Leung

Scrivania in legno e marmo con cassetteria orientabile. Struttura della cassetteria in multistrati curvato rivestito in essenza oppure laccato, con tre cassetti. Gamba interna e profili dei cassetti in acciaio inox satinato. Sotto-top in legno laccato opaco, top in marmo sagomato e lavorato in negativo sul bordo, foro passacavi di servizio, parte terminale del top in legno laccato o rivestito in essenza. Gambe laterali in legno scolpito "a tacco" rivestite manualmente in pelle con puntali in acciaio inox satinato. Le parti in legno sono disponibili nelle finiture selezione essenze; le parti in acciaio sono disponibili nella selezione finiture metalliche satinato.

Writing desk in wood and marble with adjustable drawer unit. Drawer unit structure in curved plywood covered in veneer or lacquered (RAL/NCS colours), with 3 drawers. Internal leg and profiles of the drawers in satinized stainless steel. Top in 2 layers in lacquered wood and shaped marble, with "negative" manufacture on edge, cable outlet, end part of the top in wood covered with veneer or lacquered (RAL/NCS colours). Side legs in "heel" shaped wood, manually covered in leather, with tips in satinized stainless steel. Veneered parts available in the veneer selection finishings. Metal parts available in the satinized metal finishing selection.

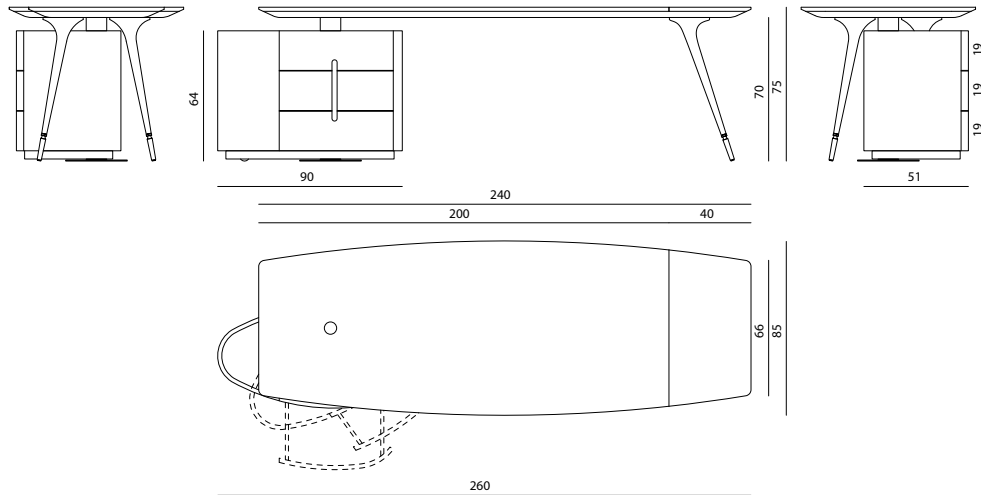

click here



WRIGHT

SCRITTOIO - WRITING DESK

Samuele Mazza

Scrittoio con struttura portante in legno curvato con due cassetti. Mobile rivestito in essenza, disponibile nelle finiture selezione essenze. La parte centrale del top è composta da un piano ribaltabile in pelle con vano portapenne e un vano di servizio con passacavi. Le parti in metallo sono disponibili nella selezione finiture metalliche satinato.

Writing desk with main structure in curved wood with 2 drawers. Desk in veneered plywood; veneer selection finishings. Openable central part of the top desk with penholder compartment and a compartment for cable passage. Metal parts available in the satinized metal finishing selection.

click here

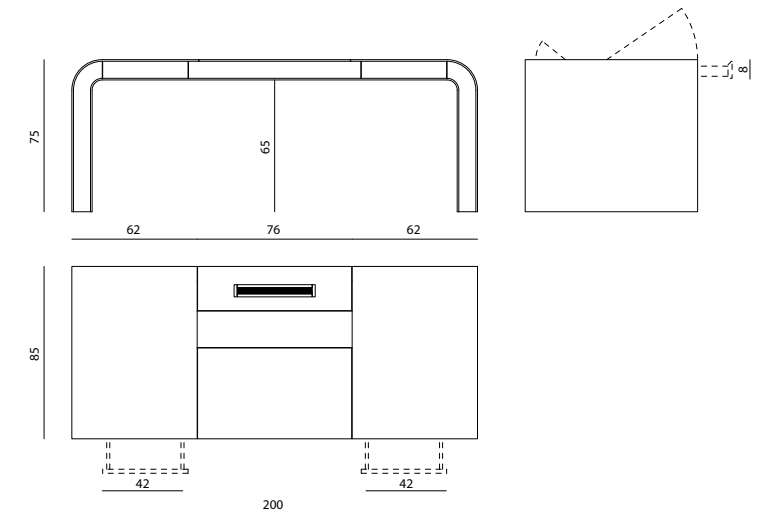



WINDSOR

SCRITTOIO CON CASSETTI

DESK WITH DRAWERS

Alessandro La Spada

Scrittoio con 2 cassetti sottopiano. Struttura mista in legno massello tulipè e MDF laccato lucido 100 gloss, con decori a rilievo. Decorazioni metalliche in ottone cromato, bracciali decorativi sui piedi in alluminio e acciaio laserato cromato. Guide cassetti bilanciate con rientro smorzato. Loghi araldici sotto lacca trasparente. Le parti in metallo sono disponibili nella selezione finiture metalliche.

Desk with 2 drawers under the top. Structure made of solid tulipè wood and glossy 100 lacquered MDF, with decorations in relief. Metallic chromed brass decorations and studs. Decorative rings over the feet made of aluminium and chromed laser cut steel. Drawer's rail balanced through a dampened return system. Visionnaire coat of arms under transparent lacquer. Metal parts can be lacquered in any colour included in the metal finish selection.

vedi anche/see also WINDSOR tavolo da pranzo-dining table, WINDSOR mobile trucco-make-up unit, WINDSOR cassettera-chest of drawers for desk, WINDSOR vetrinetta-showcase, WINDSOR parete modulare-modular elements, WINDSOR armadio-wardrobe, WINDSOR specchiera-mirror, WINDSOR vaso-vase, WINDSOR wellness room

[● click here](#)

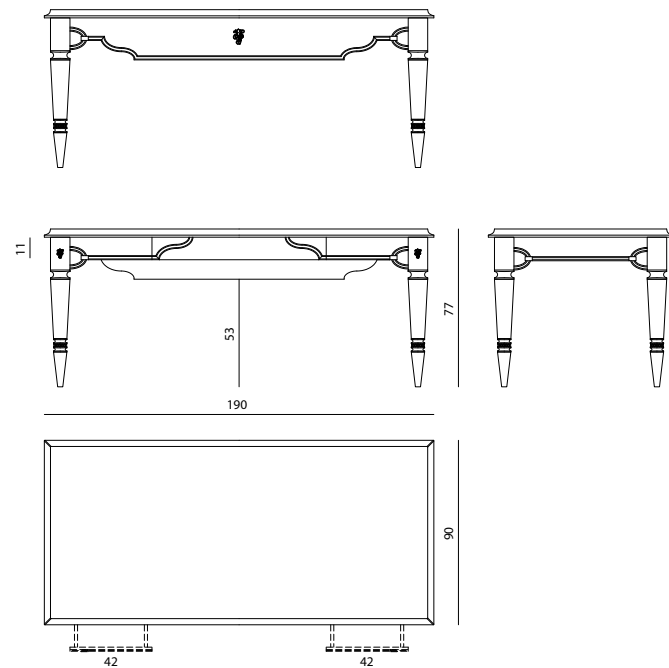

- click on the icons -



FORMA MENTIS p.348



GAYNOR p.349



GENESIS p.350



KARNAK p.351



LEONARDO p.352



OSBORNE p.353



SPEYER p.354



TIVOLI p.355



VILLA D'ESTE p.356

ICONICI - *ICONIC*



BERRY p.358



SFORZA p.359



WINDSOR p.360



WINDSOR p.361



FORMA MENTIS

LIBRERIA - BOOKSHELF

Simone Micheli

Mensole in MDF con laccatura poliesteri lucido. Montanti in MDF con stondature e fresature effetto libro laccatura poliesteri lucido. Teste in ceramica finitura lustro oro o platino, con supporto interno di sostegno in MDF stondato e laccato.

Shelves in MDF in polished polyester lacquering. Supports in MDF with roundings and millings with book effect in polished polyester lacquering. Heads in ceramic with gold or platinum finishing, with internal support in rounded and lacquered MDF.

vedi anche/see also FORMA MENTIS specchiera-mirror, FORMA MENTIS vaso-head in ceramic, FORMA MENTIS wellness room

● [click here](#)

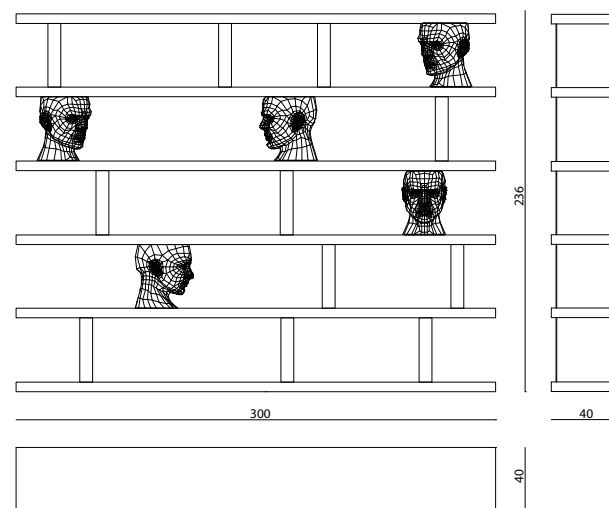
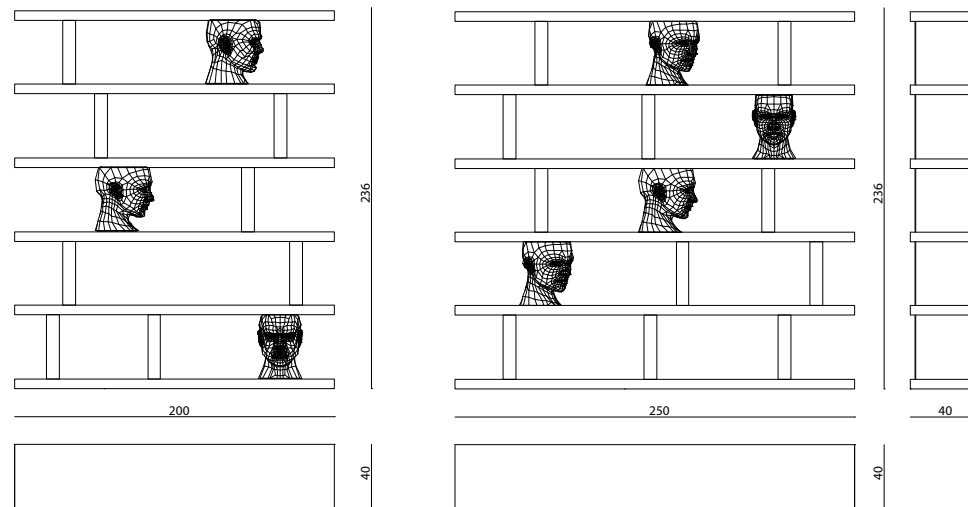

GAYNOR

LIBRERIA - BOOKSHELF

Alessandro La Spada

Libreria componibile con moduli da 40, 60 e 160 cm, H. 250 cm; spalle in MDF completamente rivestite in essenza; mensole e pannello di fondo in MDF rivestito in pelle o tessuto. 8 cassetti e 10 ante rivestiti in pelle o tessuto. Profilature, fregi e base in acciaio satinato. Interno dei vani e dei cassetti in MDF laccato opaco. Le parti in metallo sono disponibili nella selezione finiture metalliche.

Modular bookshelf with modules of 40/60 and 160 cm, H. 250 cm; internal and external vertical panels in veneered wood; shelves and bottom panels in MDF upholstered in leather or fabric. 8 drawers and 10 doors upholstered in leather or fabric. Profiles, ornaments and plinth in satinized steel. Inside of the units and drawers in matt lacquered MDF. Metal parts can be lacquered in any colour included in the metal finish selection.

● [click here](#)

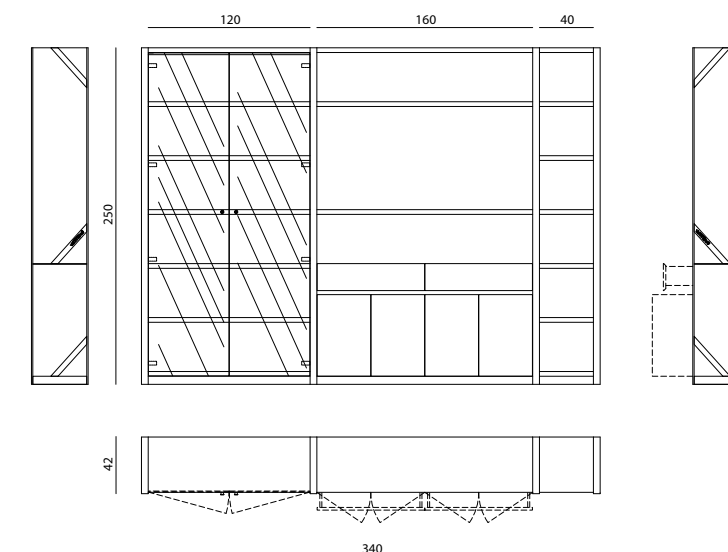
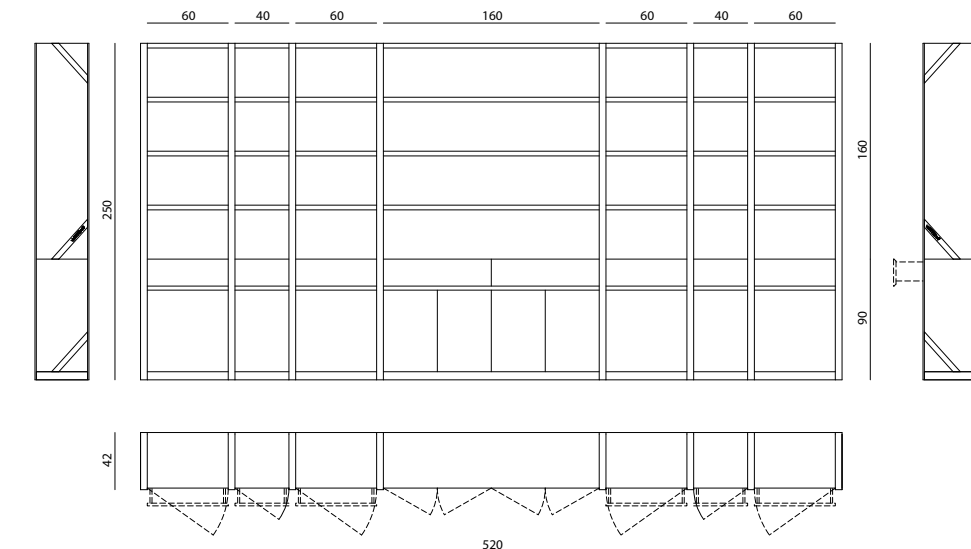



GENESIS

LIBRERIA - BOOKSHELF
Ufficio Stile Visionnaire

Sistema componibile per libreria in legno e alluminio. Disponibile in versione a moduli aperti e moduli "vetrina".

Moduli aperti: Spalle portanti composte da pannelli in legno con montanti in alluminio verniciato a polveri con profilo decorativo lucido. Pannelli laterali laccati o in essenza, oppure rivestiti in pelle o tessuto; schienale laccati o in essenza, oppure rivestiti in pelle o tessuto. Base e cappello in alluminio con top in specchio bronzo o fumé.

Moduli "vetrina": moduli chiusi da ante in cristallo temperato sciolto (sp. 8 mm) con maniglie in alluminio e impugnatura lucida o rivestita in pelle. Pannelli laterali e schienale disponibili solo rivestiti in pelle o tessuto.

I moduli sono configurabili con gli accessori interni quali:

RIPIANI - Ripiani in alluminio con top in cristallo dotati di profilo luminoso a LED.

SCAFFALI - Scaffali a giorno in legno (laccato o in essenza) con schienale in marmo e luce di cortesia perimetrale.

CASSETTIERE - Scaffali chiuso con un cestone in legno (laccato o in essenza) con possibilità di personalizzazione interna con cassetto porta posate o accessorio porta bottiglie.

La modularità del sistema prevede moduli base in tre dimensioni standard da 75, 95 e 115 cm di larghezza, modificabile nelle versioni "su misura". Il modulo "vetrina" con ante in cristallo ha misure fisse di 250 cm di altezza e 95 cm di larghezza. La profondità del modulo è fissa. L'altezza standard è di 250 cm con un massimo (per i "su misura") di 300 cm.

Le parti in metallo lucido sono disponibili nella selezione finiture metalliche, le parti in alluminio verniciato a polveri bronze sablé e manganese, le parti in legno sono disponibili nei colori RAL/NCS e nella selezione essenze.

Impianto di illuminazione a LED da collegare a rete domestica, gli alimentatori di ogni modulo sono posizionati sotto le basi.

vedi anche/see also GENESIS cabina armadio-walk-in closet

● click here



Modular library in wood and aluminium. Open units and "showcase" units available.

Open units: supporting side elements in wood with frame in powder-coated aluminium, decorate with polished metal profile. Lateral panels in lacquer or veneer finish, or upholstered in leather or fabric; back panels in lacquer or veneer finish, or upholstered in leather or fabric. Top and bottom panel in bronze or smoked mirror glass with aluminium frame.

"Vitrine" units: units with doors in box-shaped tempered crystal glass (thick. 8mm) with handles in aluminium with shiny finish or leather upholstery. Lateral and back panels available only upholstered in leather or fabric.

Units can be configured internally with the following accessories:

SHELVES - Shelf in aluminium with top in crystal glass and profile with integrated LED lights.

CHEST OF DRAWERS - Open cabinet in wood (lacquered or veneered) with back panel in marble and perimeter LED lights.

Closed cabinet with 1 basket drawer in wood (lacquered or veneered) with optional internal drawer for cutlery or bottle rack.

Modular open units available in three standard dimensions - width 75, 95, 115 cm; open units can be customised in width upon request. Vitrine units with crystal doors available only in standard size - width 95 cm x height 250 cm. Units available only in one depth. Units standard height 250 cm can be customised up to 300 cm.

Components in shiny metal can be finished with any lacquer of the shiny metal finish selection; aluminium components finished with bronze sablé or manganese powder coating; wooden elements finished with RAL/NCS lacquer or with any veneer of the wood veneer finish selection. LED lighting system to be connected to the home network, the power supplies of each module are positioned under the bases.

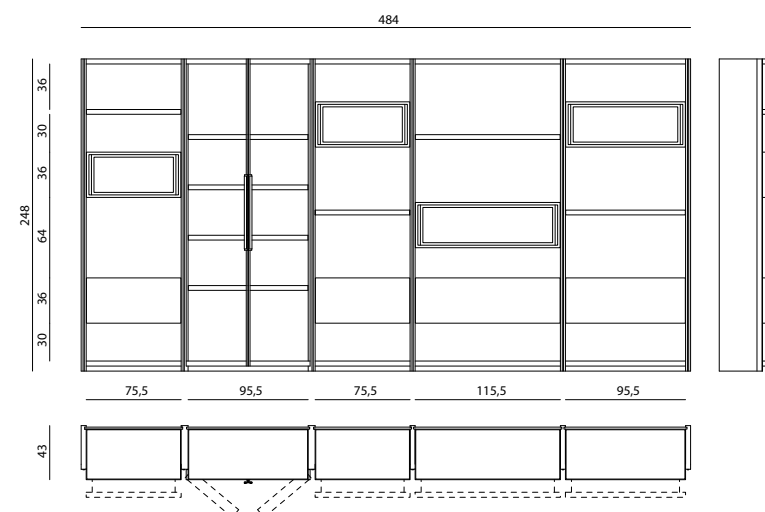

KARNAK

LIBRERIA - BOOKSHELF
Alessandro La Spada

Libreria a colonna. Spalle in legno con interni convessi rivestiti in acciaio inox. Pareti esterne in legno laccato lucido, in tinte RAL/NCS oppure placcate in essenza. Mensole a profilo alare rivestite interamente in pelle. Schienale in specchio fumé o bronzo. Illuminazione a LED di spessore ridotto incastonati nelle spalle. Predisposta per attacco a parete. Parti in metallo disponibili nella selezione finiture metalliche, le parti in legno sono disponibili nelle finiture selezione essenze oppure verniciate in colori RAL/NCS.

Column bookshelf. Sides in wood with convex interiors covered in stainless steel. Exterior of sides in polished lacquered wood, in RAL/NCS colours or covered with veneered wood. Shelves with wing-shaped profiles covered entirely in leather. Back in smoked or bronze mirror back. LED lighting of reduced thickness set in the sides. Predisposed for wall fixing. The metal parts are available in the metal finishes selection, the wooden parts are available in the veneer finishes selection or painted in RAL/NCS colours.

vedi anche/see also KARNAK consolle-console

● click here

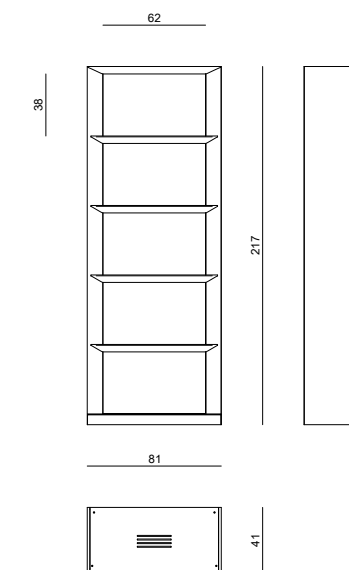



LEONARDO

LIBRERIA - BOOKSHELF

Alessandro La Spada - Samuele Mazza

Libreria a parete rivestita in pelle o tessuto. Struttura portante in metallo con schienale e fianchi in MDF sagomato e scolpito in bassorilievo con lavorazione canneté, rivestiti in pelle o tessuto. Mensole in legno ad alto spessore laccato lucido in colori RAL/NCS, con bordo inferiore luminoso. Due profili decorativi e staffe reggi-mensola in acciaio inox lucido sp. 4 mm. Le parti metalliche sono disponibili nella selezione finiture metalliche.

Wall bookshelf covered with leather or fabric. Main structure in metal with back and sides in shaped MDF decorated with 'canneté' stripes carved in low relief, covered with leather or fabric. Thick wooden shelves in shiny lacquered finish (RAL or NCS colours) with light bottom edge. Two decorative profiles and brackets in shiny stainless steel th. 4 mm. Metal parts available in the metal lacquer finish.

vedi anche/see also LEONARDO letto-bed, LEONARDO comodino-bedside table, LEONARDO cassetiera-chest of drawers, LEONARDO media-high unit, LEONARDO mobile basso-low unit, LEONARDO consolle portavavabo-wellness unit, LEONARDO mobile bar-bar unit

● [click here](#)

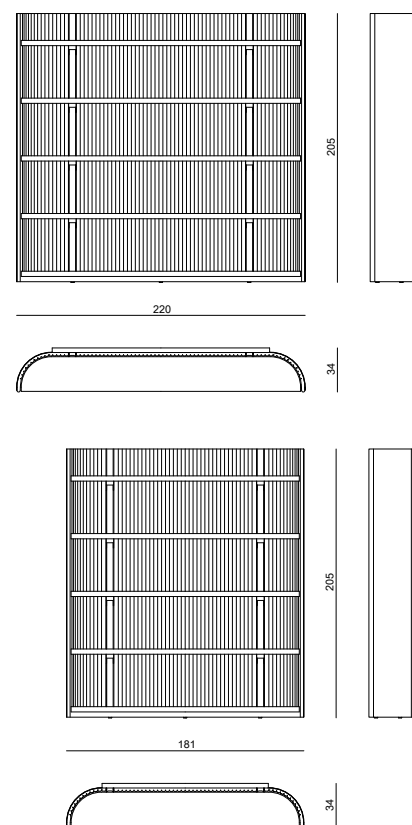

OSBORNE

PARETE ATTREZZATA - WALL UNIT

Mauro Lipparini

Sistema parete a progetto basato su una boiserie in legno con profili curvati, alternati tra concavi e convessi, mensole e profili luminosi. Ogni profilo o ripiano è bordato in acciaio inox. Sistema di attacco a muro con listelli e pannelli premontati. Finitura a poro aperto. Predisposta con luci diffuse e luci sotto mensola. Le parti in legno sono disponibili laccate a tinte RAL/NCS oppure nelle finiture selezione essenze. Le parti metalliche sono disponibili nella selezione finiture metalliche lucide.

Note importanti:

Altezza standard 260 cm
Minimo larghezza moduli 150 cm - massimo 250 cm

Wall-mounting system designed upon request; it consists of wooden panels with curved profiles, alternating convex and concave shapes, shelves and backlit profiles. Each profile or shelf has an edge in stainless steel. It can be wall mounted by means of pre-assembled slats and panels. Equipped with diffused light and under-shelves lights. Metal parts can be lacquered in any colour of the polished metal finish selection; wood parts can be finished with any veneer of the veneer selection or with RAL/NCS colour lacquering.

Important notes:

Standard height 260 cm
Minimum module width 150 cm - maximum 250 cm

● [click here](#)

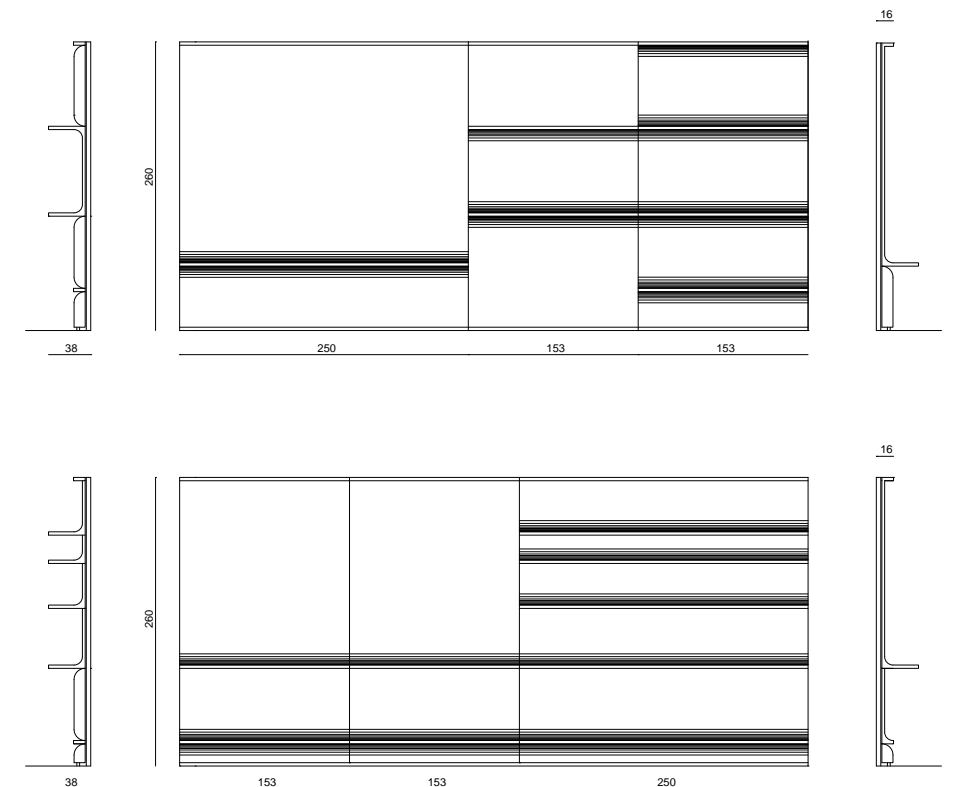

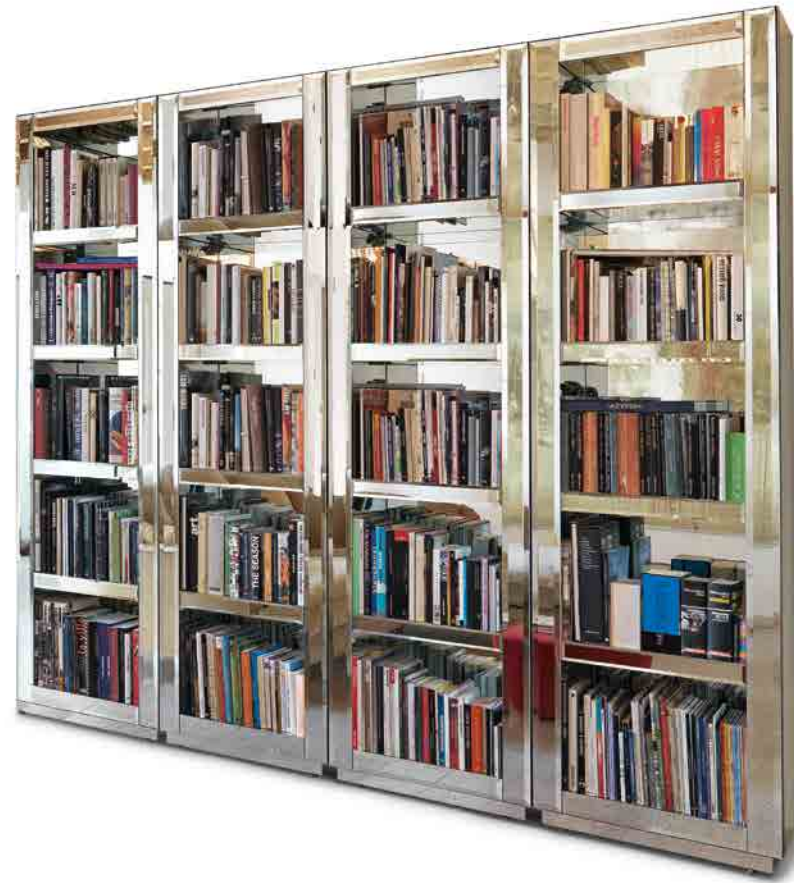

SPEYER

LIBRERIA - BOOKSHELF

Alessandro La Spada - Samuele Mazza

Struttura portante in pannello multistrati e listelli in legno di abete. Fianchi, top e fronte rivestiti in vetro specchio bisellato, spessore mm 6. Rivestimento interno e di fondo in vetro specchio spessore mm 4.

Support structure in plywood panels and fir wood strips. Sides, top and front covered in mirrored bevelled glass, thickness 6 mm. Internal and bottom covering in mirrored glass thickness 4 mm.

● [click here](#)

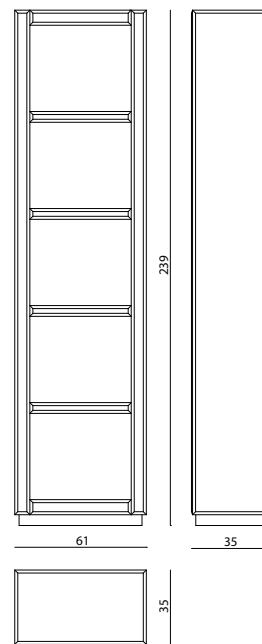

TIVOLI

LIBRERIA - BOOKSHELF

Mauro Lipparini

Sistema parete a progetto basato su una boiserie in legno con profili curvati, alternati tra concavi e convessi. Le mensole sono in vetro bronzo sp. 12 mm. Sistema di attacco a muro con listelli e pannelli pre-montati. Finitura 5 gloss. Le parti in legno sono disponibili laccate a tinte RAL/NCS oppure nelle finiture selezione essenze. I profili decorativi metallici sono disponibili nella selezione finiture metalliche.

Project wall system based on a wooden paneling with curved profiles, alternating between concave and convex. The shelves are made of 12 mm thick bronze glass. Wall fixing system with pre-assembled laths and panels. 5-gloss finish. The wooden parts are available lacquered in RAL/NCS colours or in veneer selection finishes. Metal decorative profiles are available in the metal finish selection.

vedi anche/see also TIVOLI vetrinetta-bookshelf

● [click here](#)

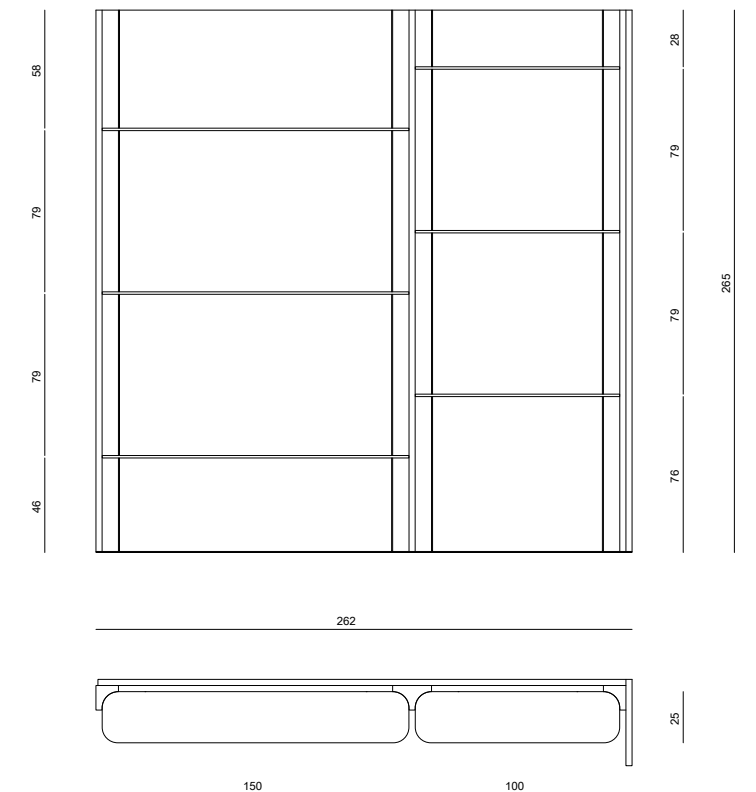

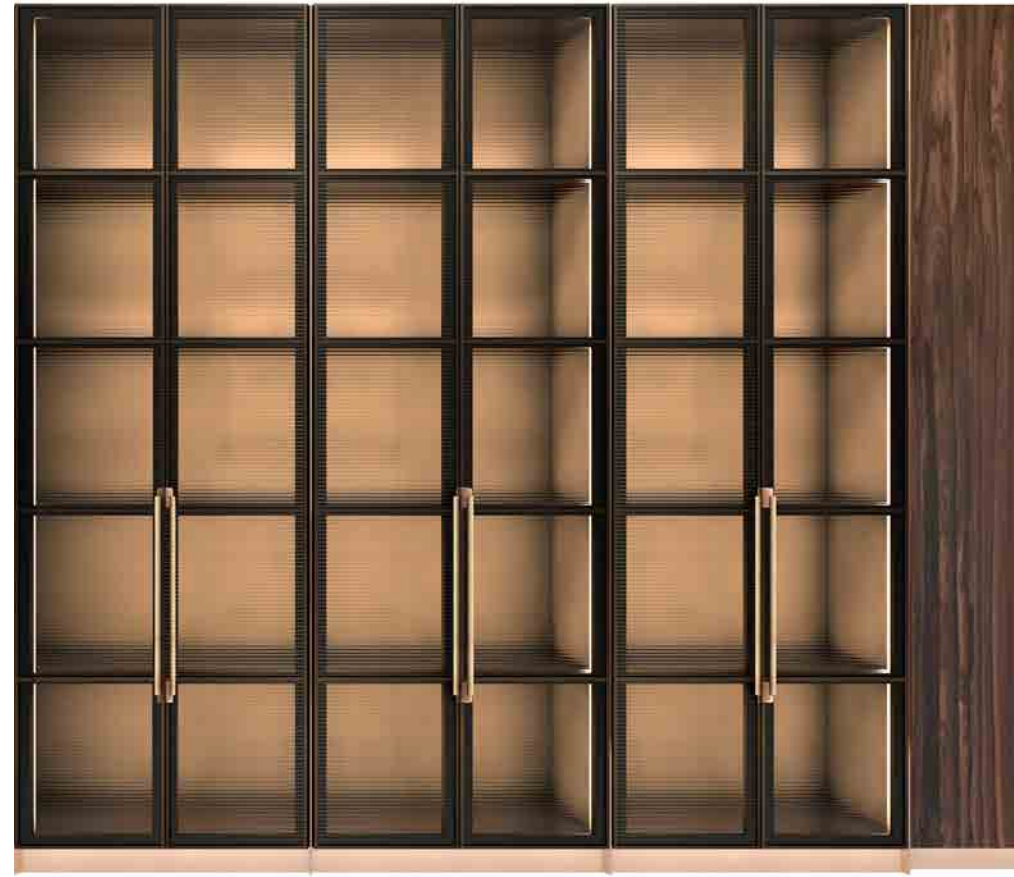

VILLA D'ESTE

VETRINETTA - SHOWCASE

Mauro Lipparini

Vetrinetta con mobili in legno rivestiti internamente in pelle o tessuto, con ante in alluminio e vetro rigato orizzontale. Le ante e le mensole interne hanno un telaio in alluminio trafilato verniciato a polveri e pannelli in vetro. Zoccoli, profili e dettagli in acciaio satinato disponibili nella selezione finiture metalliche. Vani interni illuminati a LED.

Showcase with wooden furniture covered internally with leather or fabric, with aluminium doors and horizontal ribbed glass. The doors and internal shelves have a drawn, powder-coated aluminium frame and glass panels. Satin-finish steel plinths, profiles and details available in the metal finish selection. LED-illuminated interior compartments.

vedi anche/see also TIVOLI vetrinetta-bookshelf

● [click here](#)

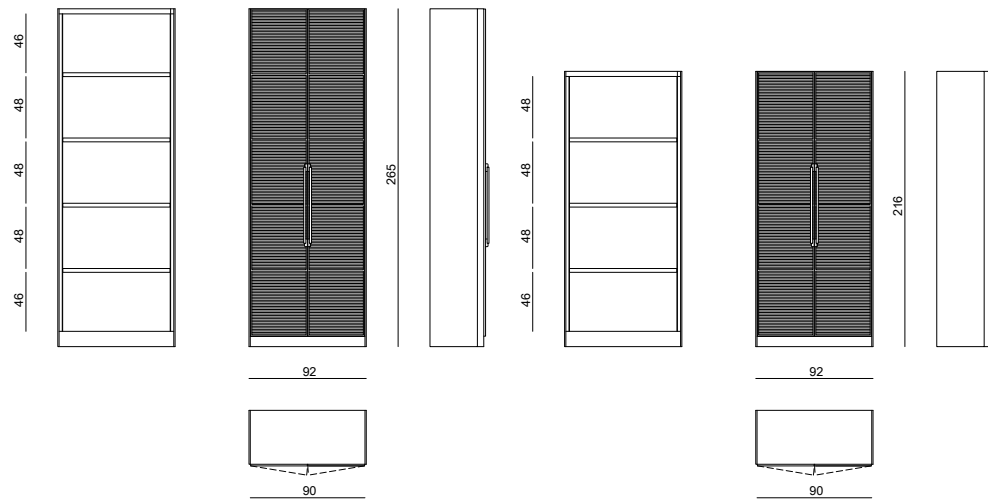



BERRY

COLONNA VETRINETTA
GLASS COLUMN CABINET
Giuseppe Viganò

Vetrinetta in cristallo temperato spessore 8mm disponibile naturale/bronzo/fumé e schienale in legno rivestito in specchio bisellato naturale/bronzo/fumé. Anta composta da tre lati in vetro saldato a UV, incisa internamente a motivo geometrico, maniglia in alluminio tornito e nappa di pelle. Top e base in MDF laccato lucido (colori RAL) con profilo e angolari in acciaio inox lucidato. Disponibile anche con illuminazione interna con luce LED con accensione tramite sensore di movimento in prossimità dello zoccolo. Il mobile deve essere fissato a parete. Le parti in metallo sono disponibili nella selezione finiture metalliche.

Column in 8 mm. thick tempered crystal (natural/bronze/fumé) and wood background covered in bevelled mirror (natural/bronze/fume). Three-sided door in UV welded glass, with inner geometric design engraving, turned aluminium and leather tassel handles. Top and base in polish lacquered MDF (RAL colours) with angles and outline in polished stainless steel. Also available with inner LED illumination through movement sensors near the plinth. The unit must be fixed to the wall. Metal parts can be lacquered in any colour included in the metal finish selection.

vedi anche/see also BERRY divano, poltrona-sofa, armchair

click here

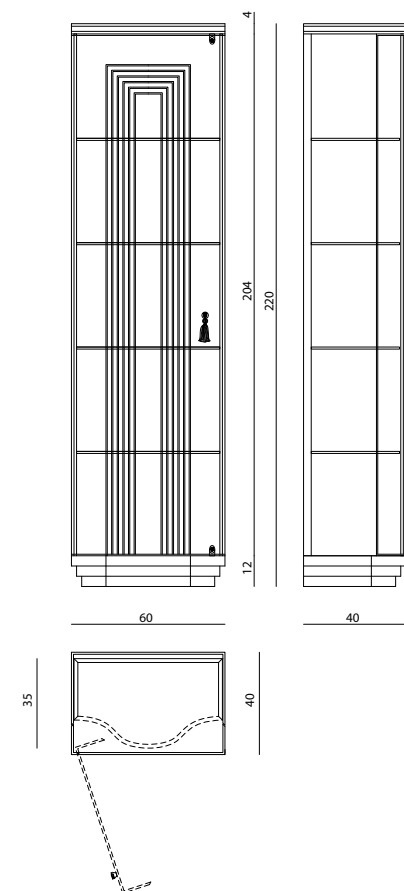

SFORZA

VETRINETTA - SHOWCASE
Alessandro La Spada

Vetrina in cristallo con struttura portante in acciaio profilato a incastro. Pannellatura posteriore superiore e di base in MDF laccato lucido. Fianchi in vetro curvo da 8 mm di spessore, ante in vetro da 8 mm temperato con grafica satinata su richiesta, e mensole in vetro da 8 mm temperato. Staffe di supporto mensole in acciaio inox lucido. Profili di base e top in acciaio inox lucido. In opzione lampada interna applique Esmeralda. Maniglie a scudo in pelle e ottone o cromato. Le parti in metallo sono disponibili nella selezione finiture metalliche.

Showcase in crystal. Main structure in recessed stainless steel outlines. Back upper and lower panels in shiny lacquered MDF. Sides in curved glass th. 8 mm, doors in tempered glass th. 8 mm with satinized logo on request, shelves in tempered glass th. 8 mm. Shelves' holders in polished stainless steel. Base outline and top in polished stainless steel. Internal Esmeralda wall lamp as optional. Shield handles in leather and chromed brass. Metal parts can be lacquered in any colour included in the metal finish selection.

click here

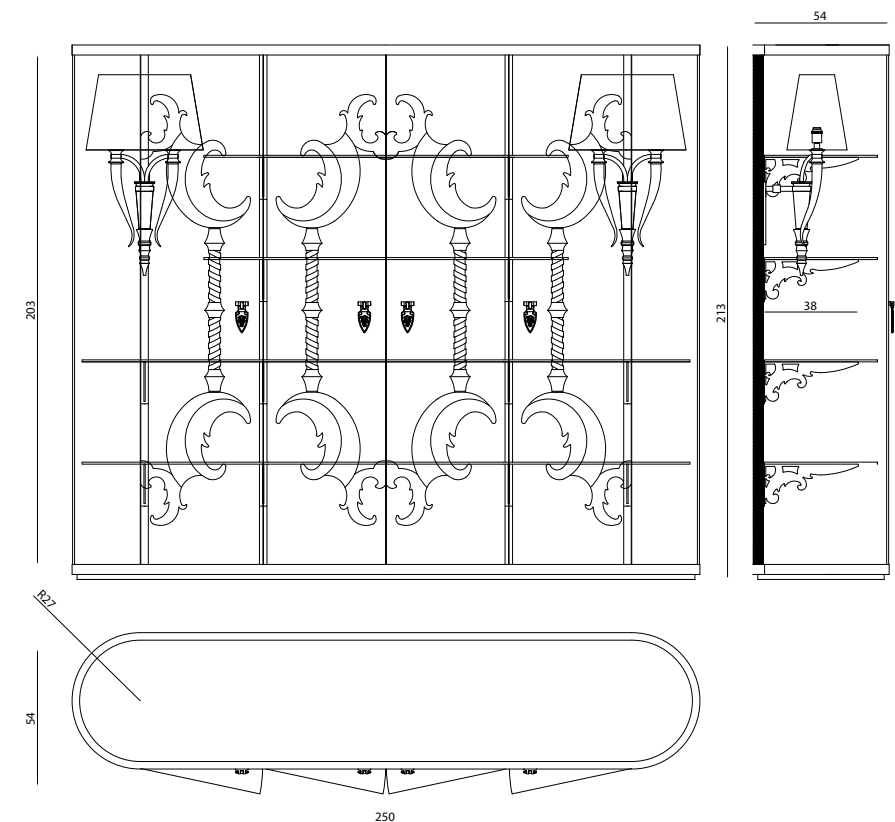



WINDSOR

VETRINETTA - SHOWCASE
Alessandro La Spada

Vetrina 4 ante vetro trasparente con maniglie a scudo con inserto in pelle e stemma araldico Visionnaire in ottone. Struttura mista in legno massello tulipè e MDF laccato lucido 100 gloss, con decori a rilievo. Decorazioni metalliche, borchie e cerniere in ottone cromato, bracciali decorativi sui piedi in alluminio e acciaio laserato cromato. Ante in cristallo 5mm, pannello di fondo laccato lucido, mensole laccate lucide con profilo frontale in acciaio inox lucidato. Illuminazione interna a led con pulsante di accensione/spegnimento inclusa. Opzione: pannello di fondo a specchio con incisione motivo ovali oppure rivestito in pelle o tessuto. Le parti in metallo sono disponibili nella selezione finiture metalliche.

Showcase with 4 transparent glass doors with shield handles and inserts in leather and brass Visionnaire coat of arms logo. Structure made of solid tulipè wood and glossy 100 lacquered MDF, with decorations in relief. Metallic chromed brass decorations, studs and joints, decorative rings over the feet made of aluminium and chromed laser cut steel. Doors in crystal 5mm, bottom panel shiny lacquered, shelves shiny lacquered with front polished stainless steel profiles. Internal LEDs lighting system with switch on/off button. Option: bottom panel either in mirror with Visionnaire ovals pattern or upholstered in leather or fabric. Metal parts can be lacquered in any colour included in the metal finish selection.

vedi anche/see also WINDSOR tavolo da pranzo-dining table, WINDSOR mobile trucco-make-up unit, WINDSOR cassetiera-chest of drawers for desk, WINDSOR scrittoio con cassetti-desk with drawers, WINDSOR parete modulare-modular elements, WINDSOR armadio-wardrobe, WINDSOR specchiera-mirror, WINDSOR vaso-vase, WINDSOR wellness room

● click here

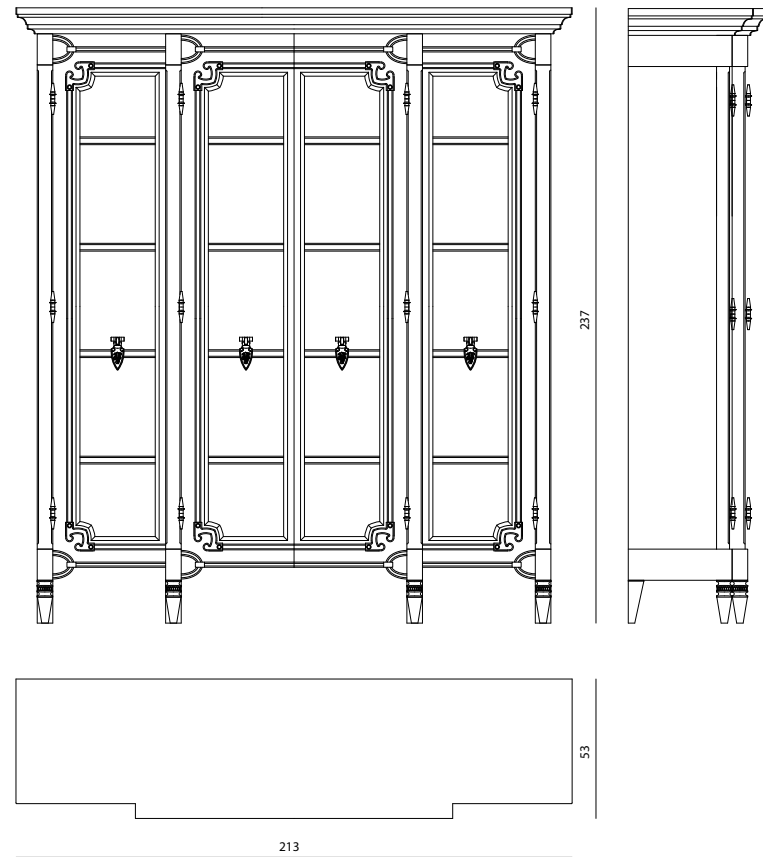

WINDSOR

PARETE MODULARE - MODULAR ELEMENTS
Alessandro La Spada

Parete modulare a doppia profondità con zoccolo e ante in vetro trasparente con maniglie a scudo con inserto in pelle e stemma araldico Visionnaire in ottone. Struttura mista in legno massello tulipè e MDF laccato lucido 100 gloss, con decori a rilievo. Decorazioni metalliche, cerniere e borchie in ottone cromato Zoccolo in massello e MDF sagomato laccato lucido 100 gloss, ante in cristallo 5mm, pannello di fondo laccato lucido, mensole laccate lucide con profilo frontale in acciaio inox lucidato. Illuminazione interna a led con pulsante di accensione/spegnimento inclusa. Opzione: pannello di fondo a specchio con incisione motivo ovali oppure rivestito in pelle o tessuto. Le parti in metallo sono disponibili nella selezione finiture metalliche.

Modular elements with with double depth. Plinth and doors in transparent glass and shield handles with inserts in leather and brass Visionnaire coats of arms logo. Structure made of solid tulipè wood and glossy 100 lacquered MDF, with decorations in relief. Metallic chromed brass decorations, studs and joints. Plinth in solid moulded 100 glossy lacquered MDF. Doors in crystal 5mm, bottom panel shiny lacquered, shelves shiny lacquered with polished stainless steel front profiles. Internal LEDs lighting system with switch on/off button. Option: bottom panel either in mirror with Visionnaire ovals design or upholstered in leather or fabric. Metal parts can be lacquered in any colour included in the metal finish selection.

vedi anche/see also WINDSOR tavolo da pranzo-dining table, WINDSOR mobile trucco-make-up unit, WINDSOR cassetiera-chest of drawers for desk, WINDSOR scrittoio con cassetti-desk with drawers, WINDSOR vetrinetta-showcase, WINDSOR armadio-wardrobe, WINDSOR specchiera-mirror, WINDSOR vaso-vase, WINDSOR wellness room

● click here

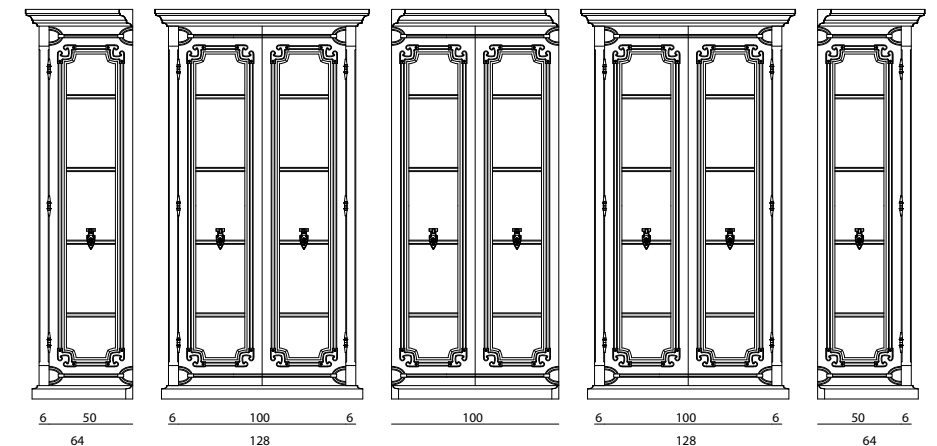
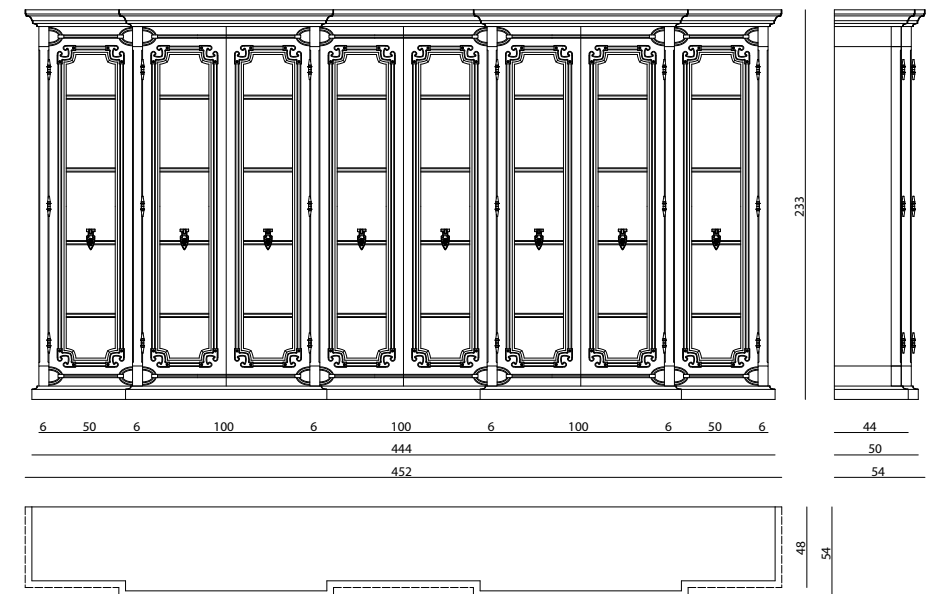

- click on the icons -



BARRYMORE p.364



GENESIS p.365



LEONARDO p.368

ICONICI - *ICONIC*



WINDSOR p.370

ART DESIGN



VENUS VEILED p.653



BARRYMORE

ARMADIO TAPPEZZATO -
UPHOLSTERED WARDROBE

Alessandro La Spada

Struttura portante pannelli con finitura gofrata, sei ante in legno rivestite da pannelli singolarmente tappezzati in pelle o tessuto a formare un motivo geometrico. Sei cestoni con guide smorzate a estrazione totale con frontale tappezzato e cassetto interno laccato opaco. Il vano centrale di quattro ante con apertura a libro, rientranti a scomparsa, ospita una libreria con fondo a specchio; le mensole sono rivestite in pelle o tessuto, le spalle, i fianchi centrali ed il fondo sono in laminato con profili in acciaio satinato. In opzione la parte centrale può ospitare uno specchio/tv da 55" con telecomando personalizzato Visionnaire in cromo o oro. I due vani laterali ospitano un ripiano e una barra appendiabiti. Maniglie in ottone satinato cromato. I cestoni si aprono tramite una gola rivestita in acciaio satinato. Disponibile illuminazione interna a LED. Le parti in metallo sono disponibili nella selezione finiture metalliche.

Main structure coated in laminated panels with embossed finishing, six doors covered with panels individually upholstered in leather or fabric, creating a geometrical effect. Six containing drawers, with damping system in the runnings, upholstered front part and mat lacquered internal drawer. The central unit consists of 4 retractable folding doors, a bookcase with bottom panel in mirror, upholstered shelves and laminated sides and bottom with satinized steel profiles. Option: central part can contain a mirror/TV 55" with Visionnaire customized remote control in chrome or gold. Side units equipped with a shelf and a crossbar. Satinized chrome brass handles. The containing drawers open with a stainless steel covered groove. Available internal LED lighting system. Metal parts can be lacquered in any colour included in the metal finish selection.

vedi anche/see also BARRYMORE cassetiera-chest of drawers

● click here

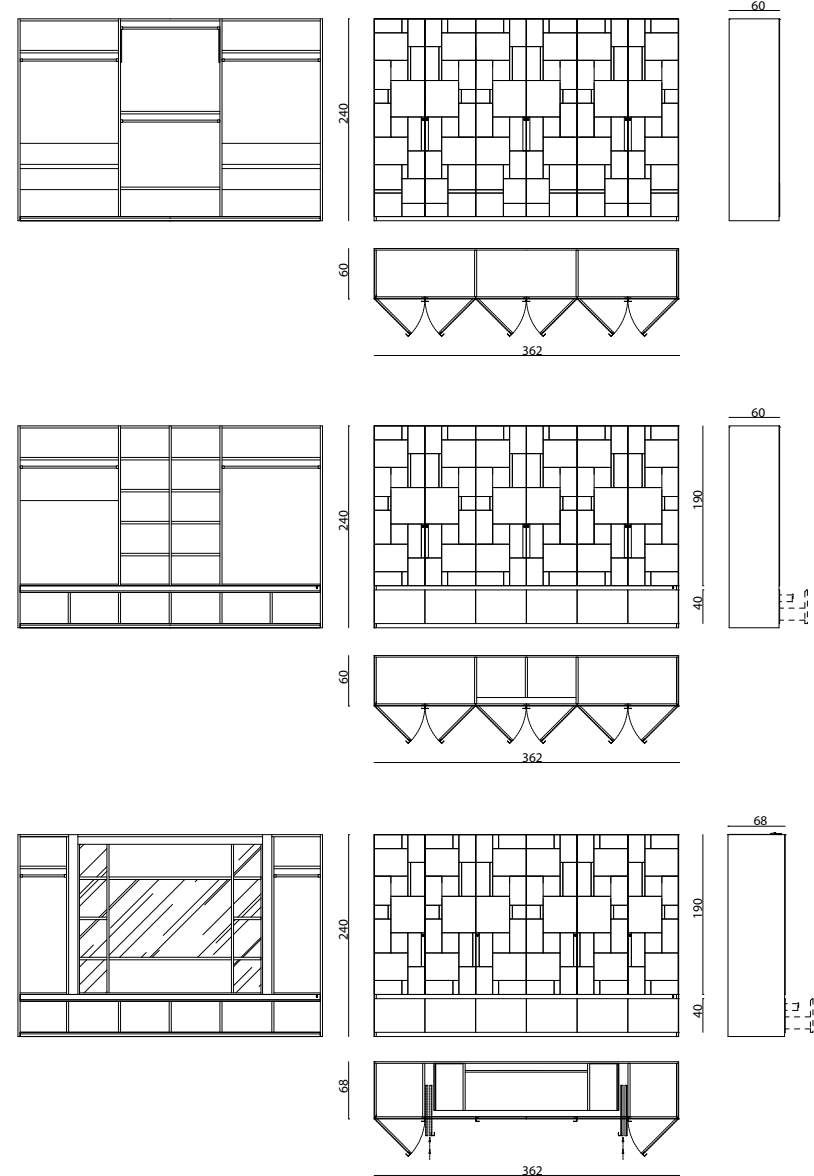

GENESIS

CABINA ARMADIO - WALK-IN CLOSET

Ufficio Stile Visionnaire

Sistema componibile per cabina armadio in alluminio e vetro.

Disponibile in versione:

- "CABINA ARMADIO A GIORNO" con moduli aperti SENZA schienale;
- "CABINA ARMADIO A GIORNO" con moduli aperti CON schienale;
- "ARMADIO" con moduli chiusi da ante in cristallo temperato scatola to (sp. 8 mm) con maniglie in alluminio e impugnatura lucida o rivestita in pelle, sia nella versione con schienale sia nella versione a doppia apertura bifacciale (versione da centro stanza).

Le spalle portanti sono composte da un doppio montante in alluminio verniciato a polveri con profilo decorativo lucido e pannelli laterali rivestiti in pelle o tessuto oppure in essenza, marmo o laminato decorativo (su progetto). Internamente sono dotate di elettrificazione per illuminazione a LED e perforatura invisibile per lo spostamento dei ripiani.

I moduli sono configurabili con gli accessori interni quali:

- RIPIANI - Ripiani in alluminio con top in cristallo dotati di profilo luminoso a LED e connettore plug & play per lo spostamento delle mensole senza bisogno di attrezzi. Sotto i ripiani si possono montare i bastoni per appendere;
- CASSETTIERE - Cassettiere e porta pantaloni con struttura in vetro e alluminio con rivestimento dei frontali in pelle o tessuto oppure in vetro nero, con top in cristallo fumé.

Gli schienali, quando presenti, sono disponibili in pelle o tessuto oppure in essenza o laminato decorativo (su progetto). La modularità del sistema prevede elementi angolari customizzabili e moduli base in tre dimensioni standard da 75, 95 e 115 cm di larghezza, modificabile nelle versioni "su misura". Il modulo "armadio" con ante in cristallo ha misure fisse di 250 cm di altezza e 95 cm di larghezza.

La profondità del modulo è fissa in 67 cm. L'altezza standard è di 250 cm con un massimo (per i "su misura") di 300 cm. I moduli sono personalizzabili attraverso una selezione di accessori divisorii per cassetti e di appenderia.

Le parti in alluminio verniciato a polveri bronze sablé e manganese, le parti in legno sono disponibili nei colori RAL/NCS e nella selezione essenze. Impianto di illuminazione a LED da collegare a rete domestica, gli alimentatori di ogni modulo sono posizionati sotto le basi.

REGOLE BASE DI CONFIGURAZIONE:

- Disponibile solo con progetto tecnico preliminare
- Profondità fissa (non personalizzabile)
- Altezza massima per moduli a giorno: 300 cm
- Aumentabile in larghezza solo nei moduli a giorno e con schienale con ripiani (non nei moduli armadio - non nelle cassettiere)
- Altezza massima moduli armadio: 250 cm
- Tutte le composizioni necessitano del 'kit fianchi terminali'

vedi anche/see also GENESIS libreria-bookshelf

● click here

Modular walk-in wardrobe in aluminium and glass.

Available in:

- "WALK-IN CLOSET" configuration with open units WITHOUT back panels;
- "WALK-IN CLOSET" configuration with open units WITH back panels;
- "WARDROBE" configuration, combining closed units with doors in crystal glass (thick. 8 mm), aluminium handles with shiny finish or upholstered in leather, with back panel or with doors on both sides (double opening suitable for centre-room installation).

Supporting lateral elements consisting of a double frame in powder-coated aluminium with polished decorative profile; side panels upholstered in leather or fabric, or covered in veneered wood, marble or decorative laminate (upon project). Internally equipped with LED lighting system and invisible pre-drilled holes allowing to shelves height adjustment.

Units can be internally configured by selecting the following accessories:

- SHELVES - Shelves in aluminium with crystal top, LED lighting profile and plug & play connector to move shelves without using hardware. Hanging rods can be mounted under the shelves;
- CHEST OF DRAWERS - Chests of drawers and trousers racks with structure in glass and aluminium, drawers front upholstered in leather or fabric or covered in black lacquered glass, top in smoked crystal glass.

Back panels, whenever selected, can be upholstered in leather or fabric or finished with veneered wood or decorative laminate (upon project). The system includes corner units fitting made-to-measure composition and linear units available in three different widths, 75 cm - 95 cm - 115 cm, which can be customised upon request. Unit with crystal doors in one size, height 250 cm - width 95 cm.

Unit depth: cm 67, equal for all sizes. Standard height: 250 cm - height can be customised up to 300 cm. Units can be customized by choosing among a selection of divider sets for drawers and hangers.

Components in shiny metal can be finished with any lacquer of the shiny metal finish selection; aluminium components finished with bronze sablé or manganese powder coating; wooden elements finished with RAL/NCS lacquer or with any veneer of the wood veneer finish selection. LED lighting system to be connected to the home network, the power supplies of each module are positioned under the bases.

CONFIGURATION BASIC RULES

- Available only with a preliminary technical project
- Fixed depth (not customizable)
- Max height for open units 300 cm
- Expandable width only with open and closed units and shelves (not for closet - not for drawers)
- Max height for closet: 250 cm
- T compositions always need the 'closing sides kit'

| | | |
|---|--------------------------------------|--------------------------------------|
| | MODULO AD ANGOLO SX CORNER UNIT L | MODULO AD ANGOLO DX CORNER UNIT R |
| | | |
| MODULO AD ANGOLO OPEN CORNER | OC2LL 64 33,5 97,5 | OC2LR 33,5 64 97,5 |
| MODULO AD ANGOLO SEMI-APERTO (CON SCHIENALE) HALF-OPEN CORNER (WITH BACK PANEL) | OC1LL 64 33,5 97,5 | OC1LR 33,5 64 97,5 |
| MODULO AD ANGOLO CHIUSO (CON SCHIENALE) CLOSED CORNER (WITH BACK PANEL) | CCL 67 33,5 100,5 | CCR 33,5 67 100,5 |

| | | |
|--------------------|---------|---------|
| | SCL | SCR |
| | | |
| RIPIANI SHELVES | 64 31,5 | 31,5 64 |

| | | |
|---|------|------|
| | SHCL | SHCR |
| | | |
| RIPIANI + APPENDIABILI SHELVES + HANGERS | | |

| | | |
|-----------------------------|------|------|
| | CHCL | CHCR |
| | | |
| APPENDIABILI CAP HANGERS | | |

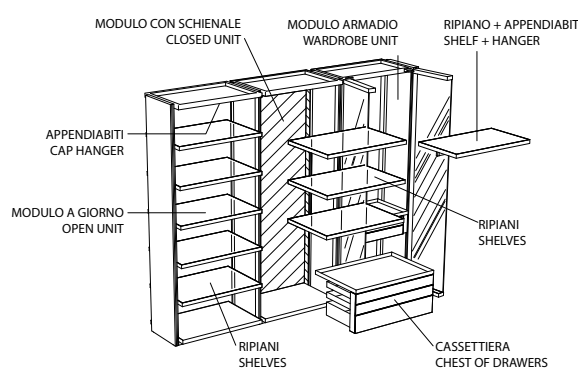
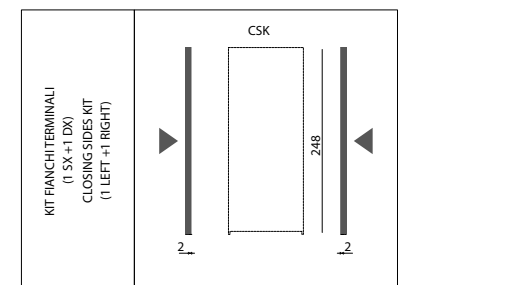

| | | | | |
|--|---------------------|---------------------|-----------------------|--|
| | MODULI UNITS | | | MODULO ARMADIO (con ante in vetro temperato e schienale) WARDROBE UNIT (with tempered glass doors and back panel) |
| | | | | |
| MODULO A GIORNO (SENZA SCHIENALE) OPEN UNITS (WITHOUT BACK PANEL) | OU755 64 79,5 | OU955 64 99,5 | OU1155 64 119,5 | W 67 102,5 |
| MODULO CON SCHIENALE CLOSED UNITS (WITH BACK PANEL) | CU755 67 79,5 | CU955 67 99,5 | CU1155 67 119,5 | |

| | | | | |
|------|------|-------|----|--------------------|
| S755 | S955 | S1155 | SW | RIPIANI SHELVES |
| | | | | |
| 75 | 95 | 115 | 95 | |

| | | | | |
|-------|-------|--------|-----|---|
| SH755 | SH955 | SH1155 | SHW | RIPIANI + APPENDIABILI SHELVES + HANGERS |
| | | | | |
| 75 | 95 | 115 | 95 | |
| CH755 | CH955 | CH1155 | CHW | APPENDIABILI CAP HANGERS |
| | | | | |
| 75 | 95 | 115 | 95 | |

| | | | | |
|--------|--------|---------|------|-----------|
| D2A755 | D2A955 | D2A1155 | D2AW | H 25,5 cm |
| | | | | |
| 75 | 95 | 115 | 95 | |

| | | | | |
|--------|--------|---------|------|--|
| D2B755 | D2B955 | D2B1155 | D2BW | H 25,5 cm (con portapantaloni with trouser holder) |
| | | | | |
| 75 | 95 | 115 | 95 | |

| | | | | |
|--------|--------|---------|------|--------------------------------------|
| D4A755 | D4A955 | D4A1155 | D4AW | H 48,8 cm 3 cassetti 3 drawers |
| | | | | |
| 75 | 95 | 115 | 95 | |

| | | | | |
|--------|--------|---------|------|--------------------------------------|
| D4B755 | D4B955 | D4B1155 | D4BW | H 48,8 cm 2 cassetti 2 drawers |
| | | | | |
| 75 | 95 | 115 | 95 | |

| | | | | |
|--------|--------|---------|------|------------------------------------|
| D8A755 | D8A955 | D8A1155 | D8AW | H 79 cm 4 cassetti 4 drawers |
| | | | | |
| 75 | 95 | 115 | 95 | |

| | | | | |
|--------|--------|---------|------|------------------------------------|
| D8B755 | D8B955 | D8B1155 | D8BW | H 79 cm 5 cassetti 5 drawers |
| | | | | |
| 75 | 95 | 115 | 95 | |

CASSETTIERE - CHEST OF DRAWERS

| | | | | |
|------------|------------------------------|-------------------------------------|---------------------------------|--|
| | MODULO A GIORNO OPEN UNIT | MODULO CON SCHIENALE CLOSED UNIT | MODULO ARMADIO WARDROBE UNIT | MODULO AD ANGOLO CORNER UNIT |
| | | | | |
| QTA QTY | ELEMENTI ELEMENTS | QTA QTY | ELEMENTI ELEMENTS | QTA QTY |
| 1 | OU755 / OU955 / OU1155 | 1 | CU755 / CU955 / CU1155 | 1 |
| 5 | S755 / S955 / S1155 | 5 | S755 / S955 / S1155 | 5 |
| 1 | OU755 / OU955 / OU1155 | 1 | CU755 / CU955 / CU1155 | 1 |
| 1 | S755 / S955 / S1155 | 1 | S755 / S955 / S1155 | 1 |
| 1 | SH755 / SH955 / SH1155 | 1 | SH755 / SH955 / SH1155 | 1 |
| 1 | OU755 / OU955 / OU1155 | 1 | CU755 / CU955 / CU1155 | 1 |
| 1 | D2A755 / D2A955 / D2A1155 | 1 | D2A755 / D2A955 / D2A1155 | 1 |
| 1 | SH755 / SH955 / SH1155 | 1 | SH755 / SH955 / SH1155 | 1 |
| 1 | OU755 / OU955 / OU1155 | 1 | CU755 / CU955 / CU1155 | 1 |
| 1 | D4B755 / D4B955 / D4B1155 | 1 | D4B755 / D4B955 / D4B1155 | 1 |
| 1 | SH755 / SH955 / SH1155 | 1 | SH755 / SH955 / SH1155 | 1 |
| 1 | OU755 / OU955 / OU1155 | 1 | CU755 / CU955 / CU1155 | 1 |
| 1 | D4A755 / D4A955 / D4A1155 | 1 | D4A755 / D4A955 / D4A1155 | 1 |
| 1 | SH755 / SH955 / SH1155 | 1 | SH755 / SH955 / SH1155 | 1 |
| 1 | OU755 / OU955 / OU1155 | 1 | CU755 / CU955 / CU1155 | 1 |
| 1 | D8B755 / D8B955 / D8B1155 | 1 | D8B755 / D8B955 / D8B1155 | 1 |
| 1 | SH755 / SH955 / SH1155 | 1 | SH755 / SH955 / SH1155 | 1 |
| 1 | OU755 / OU955 / OU1155 | 1 | CU755 / CU955 / CU1155 | 1 |
| 1 | CH755 / CH955 / CH1155 | 1 | CH755 / CH955 / CH1155 | 1 |
| 1 | SH755 / SH955 / SH1155 | 1 | SH755 / SH955 / SH1155 | 1 |
| 1 | OU755 / OU955 / OU1155 | 1 | CU755 / CU955 / CU1155 | 1 |
| 1 | D8A755 / D8A955 / D8A1155 | 1 | D8A755 / D8A955 / D8A1155 | 1 |
| 1 | CH755 / CH955 / CH1155 | 1 | CH755 / CH955 / CH1155 | 1 |
| 1 | OU755 / OU955 / OU1155 | 1 | CU755 / CU955 / CU1155 | 1 |
| 1 | D8A755 / D8A955 / D8A1155 | 1 | D8A755 / D8A955 / D8A1155 | 1 |
| 1 | CH755 / CH955 / CH1155 | 1 | CH755 / CH955 / CH1155 | 1 |
| | | | | ACCESSORI ACCESSORIES |
| | | | | |
| | | | | D755/01 D955/01 DAW955/01 DA1155/01 |
| | | | | DIVISORI DIVIDERS |
| | | | | |
| | | | | D755/02 D955/02 DAW955/02 DA1155/02 |
| | | | | PORTAOCCHIALI E OROLOGI GLASS AND WATCHES HOLDERS |
| | | | | |
| | | | | D755/03 D955/03 DAW955/03 DA1155/03 |
| | | | | PORTAPANTALONI TROUSERS HANGER |
| | | | | |
| | | | | D755/04 D955/04 DAW955/04 DA1155/04 |
| | | | | PORTAOCCHIALI E CINTURE GLASS AND BELTS HOLDERS |
| | | | | |
| | | | | D755/05 D955/05 DAW955/05 DA1155/05 |
| | | | | DIVISORI DIVIDERS |
| | | | | |
| | | | | D755/06 D955/06 DAW955/06 DA1155/06 |
| | | | | PORTAGIOIELLI JEWELRY HOLDER |
| | | | | |
| | | | | D755/07 D955/07 DAW955/07 DA1155/07 |
| | | | | PORTACINTURE E CRAVATTE BELTS AND TIES HANGERS |
| | | | | CH |
| | | | | GRUCCIA COAT HANGER |
| | | | | BH |
| | | | | APPENDIBORSE BAGS HANGER |
| | | | | SH |
| | | | | ANELLO PORTASCARPE E FOULARD SCARVES AND HEADSCARVES HANGER |
| | | | | TH |
| | | | | ASTA PORTACRAVATTE TIE HANGER ROD |



LEONARDO

ARMADIO - WARDROBE

Alessandro La Spada

Armadio in legno e pelle. Ante a doppia finitura con pannelli inferiori scolpiti in legno con lavorazione superficiale canneté in bassorilievo, rivestiti in pelle o verniciate lucide nei colori RAL. Pannelli superiori lisci rivestiti in pelle a contrasto, bordi finiti con profili in alluminio satinato. Ante laterali terminali disponibili con pannelli curvi scolpiti e rivestiti in pelle. Maniglioni a barra verticale da 110 cm con frontale piano e bordo posteriore semicilindrico alluminio fresato e lucidato, con inserto a filo in marmo. Interno ante e vani impiallacciati, struttura in legno a pannelli in multistrato e MDF. Zoccolo in acciaio inox lucido curvato.

Allestimento interno a mensole o cassettiere, rivestite in pelle. Barre porta-abiti in acciaio galvanico, disponibili con servetti motorizzati, parzialmente rivestiti in pelle. Disponibile con elemento "nicchia" con basamento in marmo e nicchia concava in pelle trapuntata con trama cannettata. Le parti in metallo sono disponibili nella selezione finiture metalliche. Disponibile con illuminazione interna a LED.

Wardrobe in wood and leather. Doors in double finish with bottom panels decorated with 'canneté' stripes carved in low relief, upholstered in leather or available with shiny lacquer RAL colours. Plain upper panels covered with contrast leather, edges with profiles in satin aluminium. Terminal side doors available with curved panels, carved and upholstered in leather. Vertical handles by 110 cm with straight front and half-cylindrical back edge in milled and polished aluminium, with insert in marble. Interior of doors and compartment in veneered wood, wooden structure made of panels in multiply and MDF. Plinth in shiny curved stainless steel.

Equipped with shelves or chest of drawers, covered with leather. Clothes rails in galvanised steel, available with motorised lifts, partially upholstered in leather. Available with "niche" element with marble base and concave niche in quilted leather with quilted texture. Metal parts are available in the metal finish selection. Available with LED interior lighting.

vedi anche/see also LEONARDO letto-bed, LEONARDO comodino-bedside table, LEONARDO cassettera-chest of drawers, LEONARDO media-high unit, LEONARDO mobile basso-low unit, LEONARDO consolle portalavabo-wellness unit, LEONARDO mobile bar-bar unit, LEONARDO libreria-bookshelf

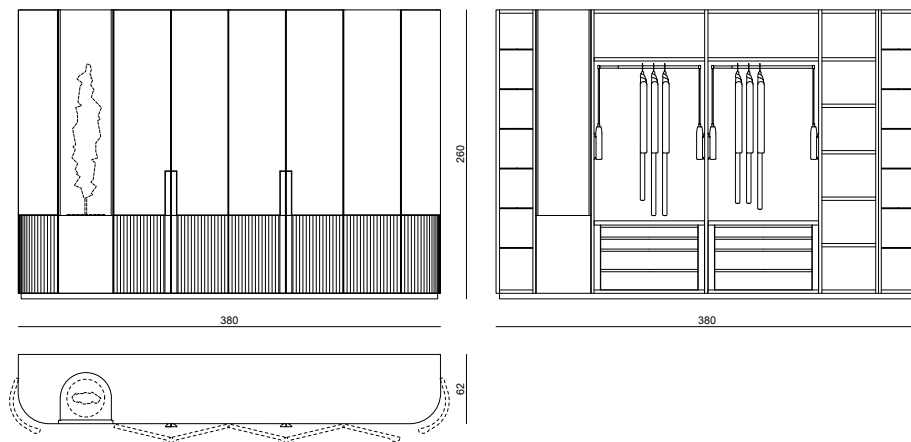

VENUS VEILED

SCULTURA - SCULPTURE

Alessandro La Spada

Scultura in blocco di marmo Rosa Portogallo, fresato e finito a mano con inserti in semipreziosi. Basamento in acciaio lucidato, disponibile nella selezione finiture metalliche. Edizione limitata e numerata di 10 pezzi.

Sculpture in Rosa Portogallo marble block, milled and finished by hand with semi-precious stone inserts. Polished steel base, available in a selection of metal finishes. Limited and numbered edition of 10 pieces.

[click here](#)

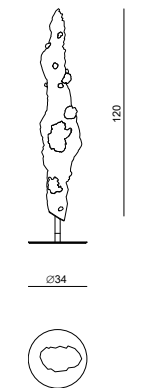

[click here](#)



WINDSOR

ARMADIO - WARDROBE

Alessandro La Spada

Armadio modulare 2 ante con cornice in MDF lavorata a rilievo e pannello in specchio inciso con trama "a ovali" con maniglie a scudo con inserto in pelle e stemma araldico Visionnaire in ottone. Struttura mista in legno massello tulipè e MDF laccato lucido 100 gloss, con decori a rilievo. Decorazioni metalliche, borchie e cerniere in ottone cromato. Interni con finitura lucida, mensole laccate con finitura antigraffio. Allestimento interno con barra portabiti, ripiani e cassettiere, personalizzabile su progetto. Zoccolo e cimasa in MDF sagomato laccato lucido 100 gloss. Illuminazione interna con luci a led, accensione all'apertura tramite sensore ottico. Opzione: rivestimento pannello di fondo in pelle o tessuto. Le parti in metallo sono disponibili nella selezione finiture metalliche.

Modular wardrobe with 2 shutters framed in MDF decorated in relief and panel in mirror engraved with "Visionnaire Ovals" pattern with shield handles with inserts in leather and brass Visionnaire coats of arms logo. Structure made of mixture of solid tulipè wood and glossy 100 lacquered MDF, with decorations in relief. Metallic chromed brass decorations, joints and studs. Internal spaces finished in shiny lacquer, shelves finished with anti-scratches lacquer. Equipped inside with clothes hanger bar, shelves and drawers, customized on request. Plinth and cyma made of moulded glossy 100 lacquered MDF. Internal LEDs lighting system, turning on system by optic sensors at doors opening. Option: bottom panel upholstery in leather or fabric. Metal parts can be lacquered in any colour included in the metal finish selection.

vedi anche/see also WINDSOR tavolo da pranzo-dining table, WINDSOR mobile trucco-make-up unit, WINDSOR cassetiera-chest of drawers for desk, WINDSOR scrittoio con cassetti-desk with drawers, WINDSOR vetrinetta-showcase, WINDSOR parete modulare-modular elements, WINDSOR specchiera-mirror, WINDSOR vaso-vase, WINDSOR wellness room

● [click here](#)

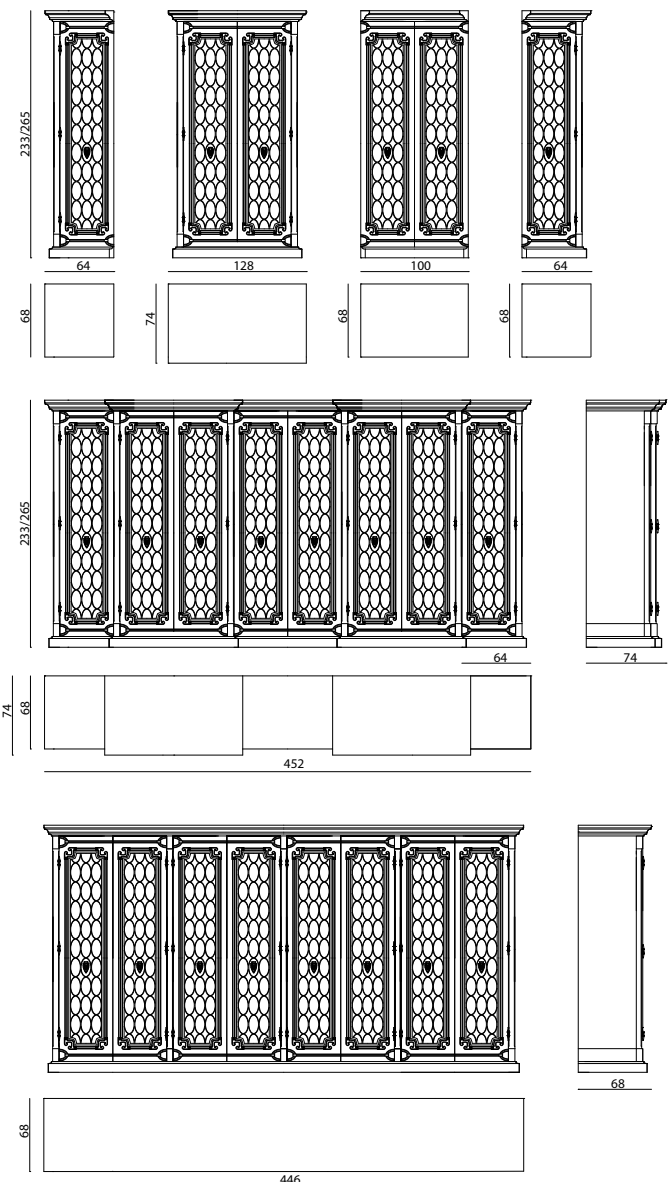

Esempi di composizione a doppia profondità
Composition examples with double depth

Esempi di composizione a profondità costante
Composition examples with constant depth



SELEZIONE ESSENZE VENEER SELECTION

GRUPPO R/GROUP R



R.001
RADICA DI NOCE
BURR WALNUT



R.002
RADICA DI NOCE
BURR WALNUT

GRUPPO A/GROUP A



A.721
RADICA FRASSINO
ASH BURL



A.722
RADICA FRASSINO
ASH BURL



A.992
RADICA NOCE
WALNUT BURL

GRUPPO B/GROUP B



B.558
ERABLE
MAPLE BURL



B.827
ERABLE
MAPLE BURL



B.002
RADICA EUCALIPTUS
EUCALYPTUS BRIAR WOOD



B.180
FIAMMATO SABBIA
FLAMED SAND



B.181
FIAMMATO GRIGIO
FLAMED GRAY



B.182
FIAMMATO NERO
FLAMED BLACK

SELEZIONE FINITURE METALLICHE METAL FINISHES SELECTION

GRUPPO C/GROUP C



C.902
SICOMORO FRISÉ
SYCOMORE FRISÉ



C.321
PALISSANDRO SANTOS
ROSEWOOD SANTOS



C.EBANO
EBANO
EBONY



C.507
EUCALIPTO FRISÉ
EUCALYPTUS FRISÉ



C.510
EUCALIPTO FRISÉ
EUCALYPTUS FRISÉ



C.001
FRASSINO
GREY ASH



C.044
DATUK EBANO
DATUK EBONY

GRUPPO Z/GROUP Z



ZIR-AR2
ZIRICOTE
ZIRICOTE

LUCIDI/POLISHED



BRONZO
BRONZE



CHAMPAGNE
CHAMPAGNE



ORO
GOLD



SIENA
SIENA



CANNA DI FUCILE
GUNMETAL



NICHEL NERO
NICKEL BLACK



CROMO
CHROME

SATINATI/SATIN



BRONZO
BRONZE



CHAMPAGNE
CHAMPAGNE



ORO
GOLD



SIENA
SIENA

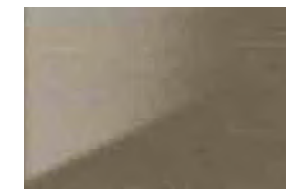

CANNA DI FUCILE
GUNMETAL



NICHEL NERO
NICKEL BLACK



CROMO
CHROME

- click on the icons -

- click on the icons -



ACER p.378



ALLEY p.378



BALIN, ELMO
GALDOR, TAREG p.379



BARNUM p.379



BLANCHE SNAKE,
BLANCHE GIRL p.380



BORGIA p.380



MIDNIGHT p.385



MILO p.386



PERKINS p.386



POLIDORO p.387



REBEL p.387



TALOS p.388



DELANO p.381



DIAMOND p.381



FORMA MENTIS p.382



WESTLEY p.388



WINDSOR p.389



FOUQUET p.382



GONDAR p.383



GRIMILDE p.383



JET PLANE p.384



KUDRUN p.384



MAREY p.385



CHARADE p.391

ICONICI - *ICONIC*



ACER

SPECCHIERA - MIRROR
La Conca

Struttura in compensato multistrati spess. mm 10. Bordatura perimetro interno ed esterno della cornice in laminato acciaio. Specchio bisellato. Cornice rivestita con formelle di specchio o vetro retro laccato, bisellate su 4 lati. Formelle con stemma araldico Visionnaire posizionate nei quattro angoli.

Structure in honeycomb board plywood, th. mm 10. Internal and external border of the frame in steel laminate. Bevelled mirror. Frame covered with mirror or lacquered glass tiles, bevelled on all 4 sides. Tiles with Visionnaire logo placed in the four corners.

vedi anche/see also ACER tavolo basso-low table, ACER consolle-console

● click here

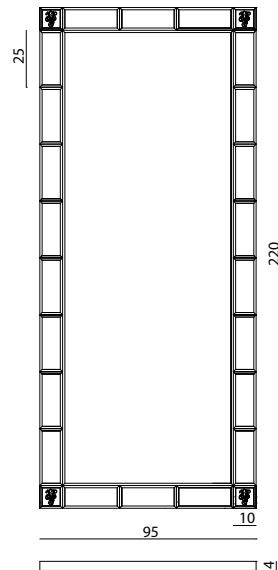

ALLEY

SPECCHIERA - MIRROR
Alessandro La Spada

Cornice in tubolare a sezione ovale mm 60x30 in ottone cromato. Specchio con fascia perimetrale sabbata e logo Visionnaire, con retroilluminazione LED a luce calda. Pannello posteriore in MDF laccato bianco. Supporto di sostegno a due vie in tubo cromato con puntali in alluminio tornito cromato. Le parti in metallo sono disponibili nella selezione finiture metalliche.

Frame with oval-sectional tube mm 60x30 in chromed brass. Mirror with sandblasted perimetral band and Visionnaire logo, provided with LED backlighting with warm light. Back panel in white lacquered MDF. Double support in chromed tube with tips in chromed turned aluminium. Metal parts can be lacquered in any colour included in the metal finish selection.

● click here

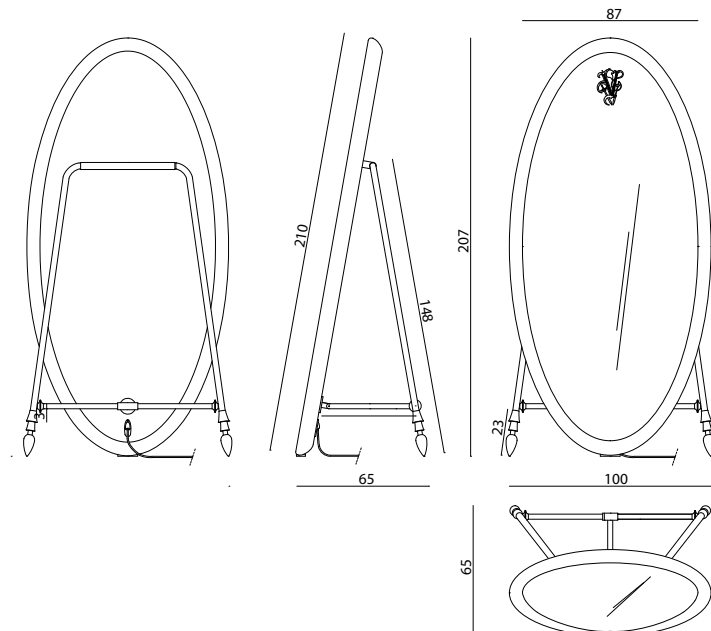

BALIN - ELMO GALDOR - TAREG

SPECCHIERA - MIRROR
Armando Bruno

Specchio in marmo e vetro accostati a filo, cornice in acciaio satinato. Marmi intarsiati in diverse combinazioni cromatiche. Il sistema di attacco prevede diverse possibilità di orientamento. Le parti in acciaio sono disponibili nella selezione finiture metalliche satinato.

Galdor: i marmi sono intarsiati a strisce di Nero Marquina, Arabescato Vagli e Grigio Bardiglio.

Balin: i marmi sono intarsiati a strisce di Nero Marquina e Arabescato Vagli.

Elmo: porzione di marmo intarsiato Arabescato Vagli.

Tareg: porzione di marmo intarsiato Arabescato Vagli o Nero Marquina.

Mirror in marble and glass, frame in thin satinized stainless steel. Marbles inlaid in different colour combinations. The attachment system provides various possibilities of orientation. Metal parts available in the satinized metal finishing selection.

Galdor: marbles inlaid with strips of Nero Marquina, Arabescato Vagli and Grigio Bardiglio.

Balin: marbles inlaid in different colour combinations.

Elmo: portion of inlaid marble Arabescato Vagli.

Tareg: portion of inlaid marble Arabescato Vagli or Nero Marquina.

Winner of the 2018 NYC X DESIGN, "Best accessories" category

● click here

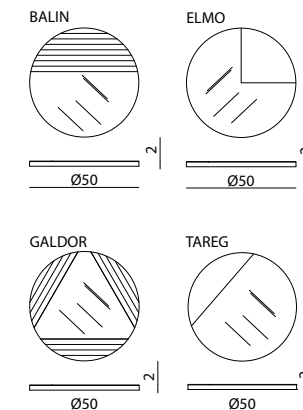

BARNUM

SPECCHIERA - MIRROR
Roberto Lazzeroni

Telaio portante in tubo acciaio inox lucido. Specchio bisellato, spessore 5 mm. Cornice in pannelli di multistrati imbottiti in poliuretano D. 21 kg/m³ con rivestimento in tessuto accoppiato a lastra di poliuretano e trapuntato con motivi geometrici o a gigli. Il telaio in metallo è disponibile nella selezione finiture metalliche.

Main structure in polished stainless steel tube. Bevelled mirror th. 5 mm. Frame made of plywood panels padded with polyurethane D. 21 kg/m³, covered with fabric coupled to a layer of polyurethane and quilted with geometric patterns or lilies. Main structure can be lacquered in any colour included in the metal finish selection.

● click here

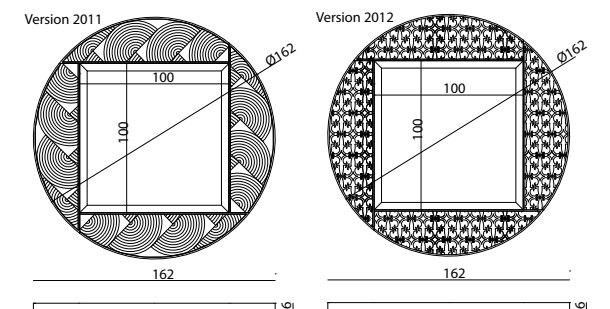



BLANCHE SNAKE, BLANCHE GIRL

SPECCHIERA - MIRROR

Studio Pepe

Specchiera da parete con cornice in legno rivestita in pelle, frange decorative in pelle ripiegabili su due embrasse in acciaio satinato disposte ai lati dello specchio. Disponibile con specchio decorato con soggetto artistico "snake" o "girl" ottenuto per incisione manuale con sabbiatura ad aerografo e argentatura.

Wall mirror with wooden frame covered in leather, leather decorative fringes foldable on two rings in satin steel placed on the sides of the mirror. Available with mirror decorated with "Snake" or "Girl" artistic subject obtained by manual engraving with airbrush sandblasting and silvering.

● click here

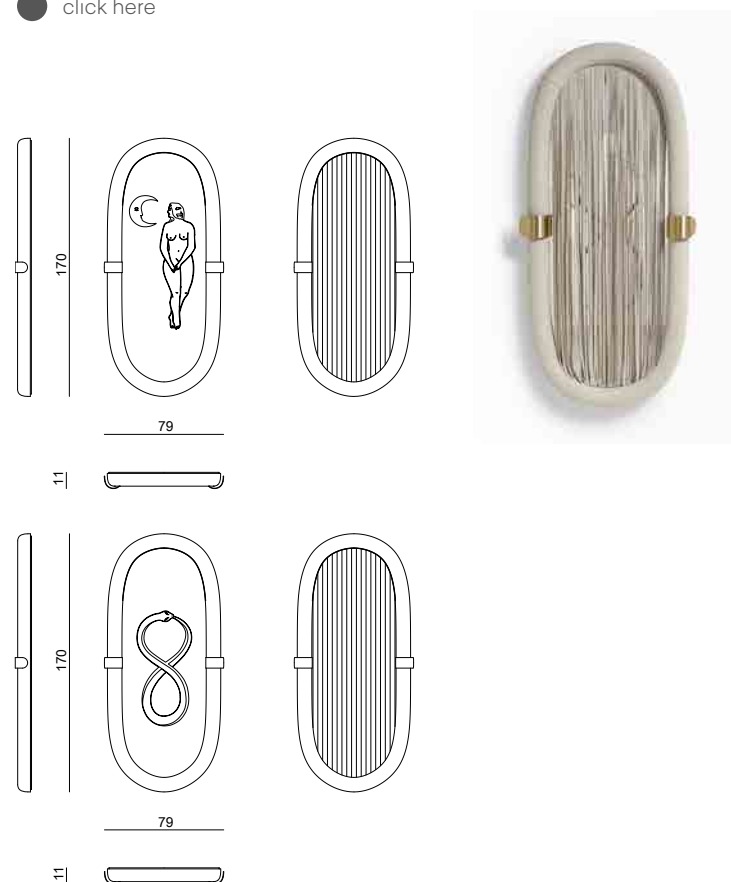

BORGIA

SPECCHIERA - MIRROR

Samuele Mazza

La ceramica (finitura lustro platino/oro oppure smalto bianco/nero) della cornice è intervallata da 6 elementi in acciaio lucido, con inciso lo stemma araldico "Visionnaire". Struttura perimetrale esterna e interna alla cornice, in acciaio finitura lucida.

The ceramic (shiny platinum/gold finishing or white/black enamelled) of the frame is spaced out by 6 elements in polished stainless steel, with the "Visionnaire" logo engraved. The External and internal perimetral structure of the frame is finished in polished stainless steel.

● click here

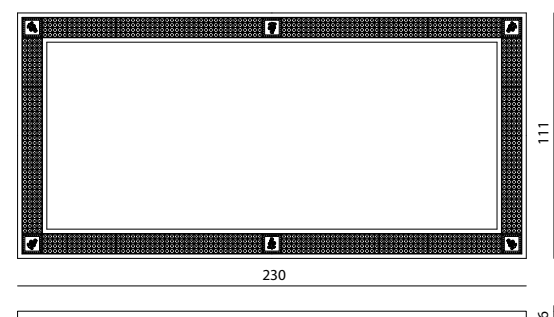

DELANO

SPECCHIERA CON CONSOLE - MIRROR WITH SHELF

Samuele Mazza

Specchiera con consolle integrata, cornice in MDF con bordo esterno laccato lucido e corpo rivestito in specchio bronzo o fumé. Mensola in MDF rivestita in specchio bronzo o fumé disponibile anche con cassetto. Specchio centrale diviso in riquadri bisellati singolarmente e decorati con borchie ottagonali in ottone con logo Visionnaire inciso. Predisposizione per appoggio a terra e attacco a parete.

Mirror with integrated console, frame in MDF with glossy lacquered external profile and structure coated in bronze or smoked mirror. Shelf in MDF coated in bronze or smoked mirror, available also with drawer. Central mirror divided in individually bevelled squares decorated with octagonal studs in brass with engraved Visionnaire logo. Predisposed for floor-and-wall fixing.

● click here

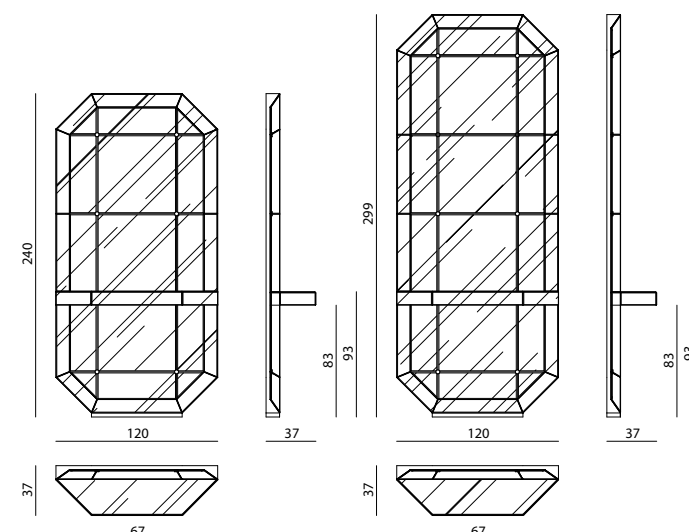

DIAMOND

SPECCHIERA - MIRROR

Samuele Mazza

Specchiera con cornice in legno, disegno a diamante. Finitura in foglia d'argento e d'oro chiara o brunita, applicata sul legno con colle naturali, secondo un procedimento in uso a Firenze fin dal 1200. Specchio lucido, spessore mm 5. Foderatura posteriore in compensato.

Large mirror with wooden diamond-shape frame. Finishing in burnished or bright silver or gold foil, which is stuck on the wood with natural glues, following an ancient procedure used in Florence since 1200. Shiny mirror with a thickness of 5 mm. Back panel in plywood.

● click here

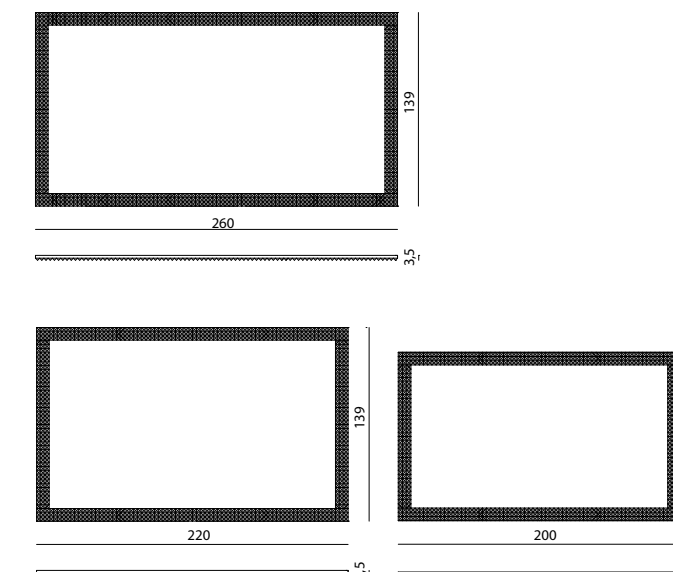



FORMA MENTIS

SPECCHIERA - MIRROR
Simone Micheli

Specchiera sfaccettata, con struttura in acciaio inox lucido.

Multi-faceted mirror, with structure in polished stainless steel.

vedi anche/see also FORMA MENTIS libreria-bookshelf, FORMA MENTIS vaso-head in ceramic, FORMA MENTIS wellness room

● [click here](#)

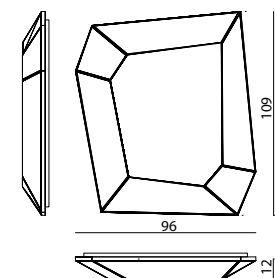

FOUQUET

SPECCHIERA - MIRROR
Maria Serebryanaya

Specchio ovale con struttura in fusione di alluminio, finitura cromo lucido o laccato oro. Applicazione di catene in alluminio cromato. Specchio sp. 5 mm.

Oval mirror structure in alloy casting, shiny chrome finishing or golden lacquered. Application of chromed chains in aluminium. Mirror th. 5 mm

vedi anche/see also FOUQUET consolle-console.

● [click here](#)

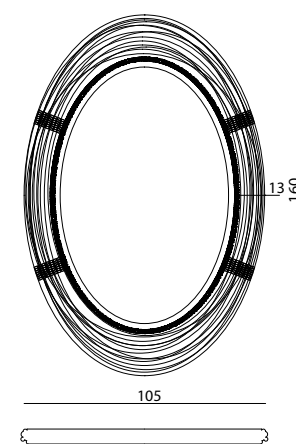

GONDAR

SPECCHIERA - MIRROR
Samuele Mazza

Specchiera con cornice ottagonale in profili di acciaio satinato e specchio alternati a scalare. Specchio centrale bisellato. Le parti in metallo sono disponibili nella selezione finiture metalliche.

Mirror with octagonal frame, profiles in satinized stainless steel and mirror digressively alternated. Bevelled central mirror. Metal parts can be lacquered in any colour included in the metal finish selection.

● [click here](#)

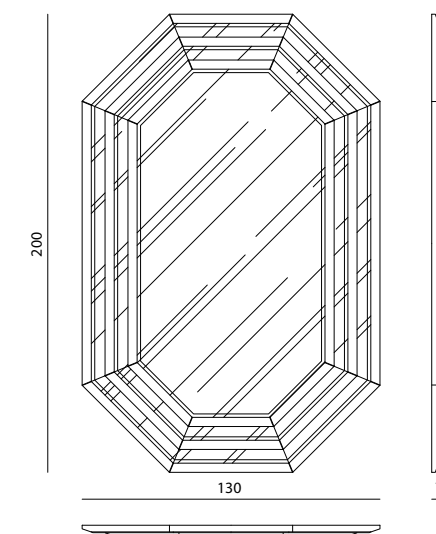

GRIMILDE

SPECCHIERA - MIRROR
Alessandro La Spada

Cornice in profilato metallico finitura laccata oro, specchio bisellato con fascia perimetrale e stemma araldico Visionnaire sabbato e retroilluminato.

Gold lacquered finish frame, bevelled mirror with perimetral band and backlighting and sanded coat of arms.

vedi anche/see also GRIMILDE mobile trucco-vanity unit, GRIMILDE wellness room

● [click here](#)

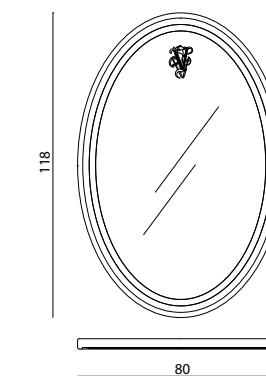



JET PLANE

SPECCHIERA - MIRROR

Steve Leung

Specchiera tonda da parete in legno laccato lucido (tinte RAL), con illuminazione di cortesia a LED su richiesta. Abbinabile su richiesta al mobile trucco Jet Plane.

Round wall mirror in glossy lacquered wood (RAL colours) which can be equipped LED light upon request. It can be combined with Jet Plane make-up desk.

● [click here](#)

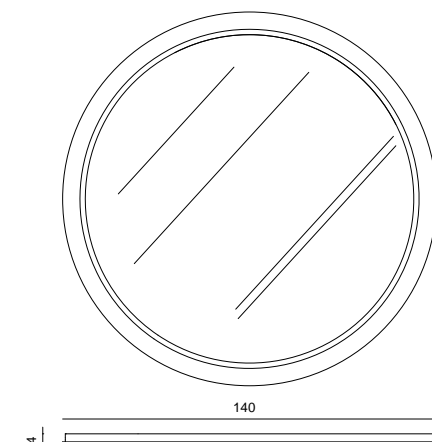

KUDRUN

SPECCHIERA - MIRROR

Alessandro La Spada - Samuele Mazza

Struttura in MDF rivestita in acciaio inox lucido spess. mm 15,5. Specchio antinfortunistica spess. mm 5. Cornice in marmo da 15 cm oppure in legno tappezzato in pelle o tessuto. Le parti in metallo sono disponibili nella selezione finiture metalliche.

Structure in MDF covered with polished stainless steel th. mm 15,5. Safety mirror th. mm 5. Marble frame of 15 cm or wood covered in leather or fabric. Metal parts can be lacquered in any colour included in the metal finish selection.

● [click here](#)

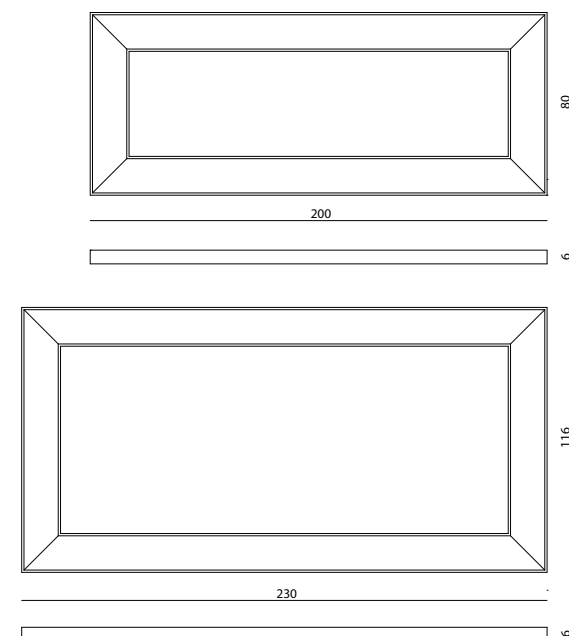

MAREY

SPECCHIERA - MIRROR

Alessandro La Spada

Specchiera con cornice tappezzata inserita in un telaio portante in tubolare acciaio inox lucido, cornice formata da pannelli in multistrato imbottiti in poliuretano rivestiti in tessuto o pelle. Inserti in acciaio satinato, specchio bisellato da 5 mm di spessore. Le parti in metallo sono disponibili nella selezione finiture metalliche.

Mirror with upholstered frame. Main structure in polished stainless steel tubes; frame consists of plywood panels padded in polyurethane and upholstered in leather or fabric. Inserts in stainless steel; bevelled mirror, 5 mm in width. Metal parts can be lacquered in any colour included in the metal finish selection.

● [click here](#)

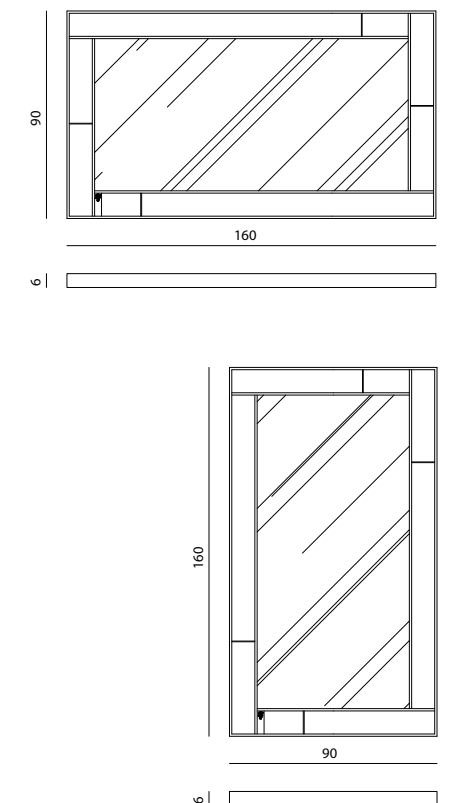

MIDNIGHT

SPECCHIO - MIRROR

Alessandro La Spada, Samuele Mazza

Cornice in multistrati con rivestimento in cristallo da mm 6, bisellato su tutti i lati, disponibile nei colori di serie. Specchio lucido da mm 5 con foderatura posteriore in compensato.

Frame in plywood with cover in crystal mm 6, bevelled on all sides, available in standard colours. Polished mirror mm 5 with back support in plywood.

vedi anche/see also MIDNIGHT media-cabinet, MIDNIGHT cassettera-chest of drawers

● [click here](#)

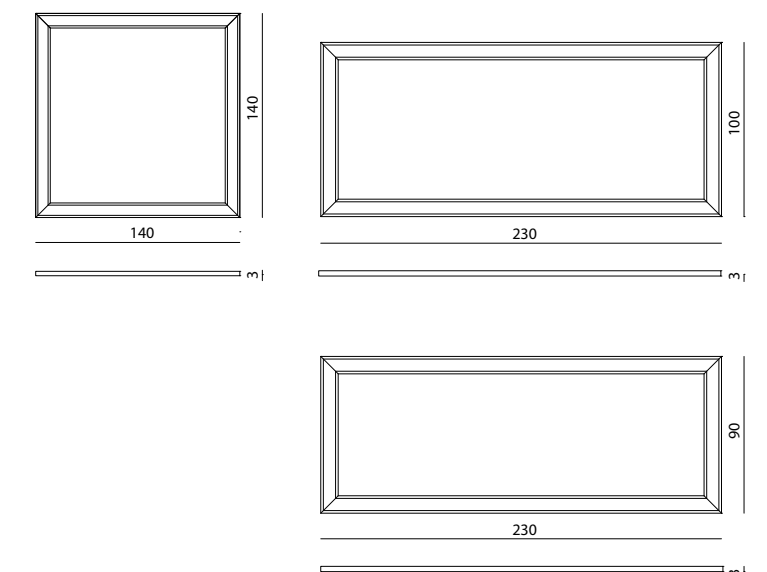

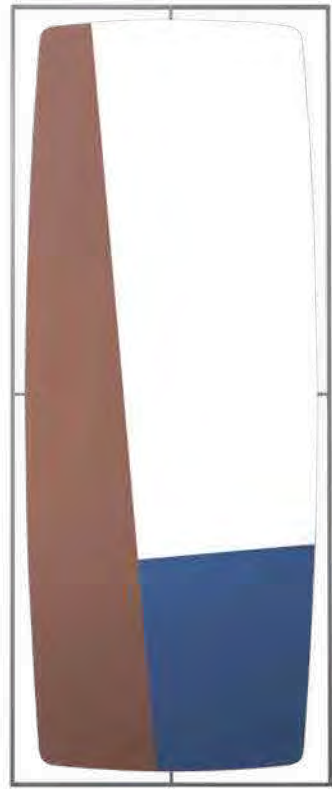

MILO

SPECCHIERA - MIRROR

Roberto Lazzeroni

Specchiera in tre sezioni cromatiche con parti in specchio naturale, rosa e azzurro. Cornice in acciaio inox satinato separata dallo specchio da quattro elementi in ottone. Fondo in legno nero.

Mirror in three chromatic sections with parts in natural, pink and blue mirror. Satinized stainless steel frame separated from the mirror by four brass elements. Black wooden back.

● [click here](#)

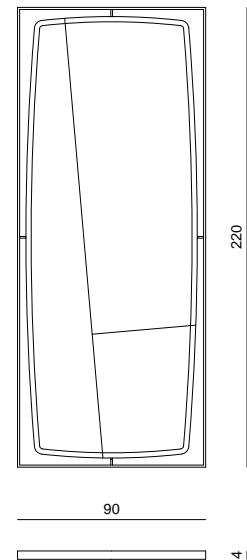

PERKINS

SPECCHIERA - MIRROR

La Conca

Cornice tappezzata in pelle o tessuto composta da formelle imbottite e rivestite con effetto cinturino. Cornice perimetrale esterna in acciaio inox lucido. Lati superiore e inferiore a specchio bisellato (chiaro/fumé/bronzo). Specchio centrale chiaro, bisellato. Le parti in metallo sono disponibili nella selezione finiture metalliche.

Upholstered frame in leather or fabric, made of padded tiles covered with strap effect. Perimetral external frame in polished stainless steel. Upper and lower sides in bevelled mirror (clear/fume/bronze). Clear central bevelled mirror. Metal parts can be lacquered in any colour included in the metal finish selection.

vedi anche/see also PERKINS letto-bed, PERKINS comodino-bedside table, PERKINS cassetiera-chest of drawers

● [click here](#)

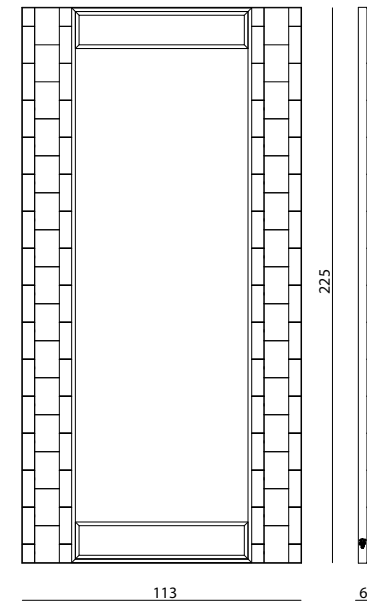

POLIDORO, POLIDORO TALL

SPECCHIERA - MIRROR

Alessandro La Spada

Specchiera con cornice in marmo inserita in un telaio portante in tubolare di acciaio inox, la cornice è composta da pannelli in due tipologie di marmo con inserti in acciaio; specchio bisellato. Le parti metalliche sono disponibili nella selezione finiture metalliche.

Mirror with marble frame inserted in a stainless steel tubular frame, the frame is composed of panels in two types of marble with stainless steel inserts; bevelled mirror. Metal parts available in the metal finishing selection.

● [click here](#)

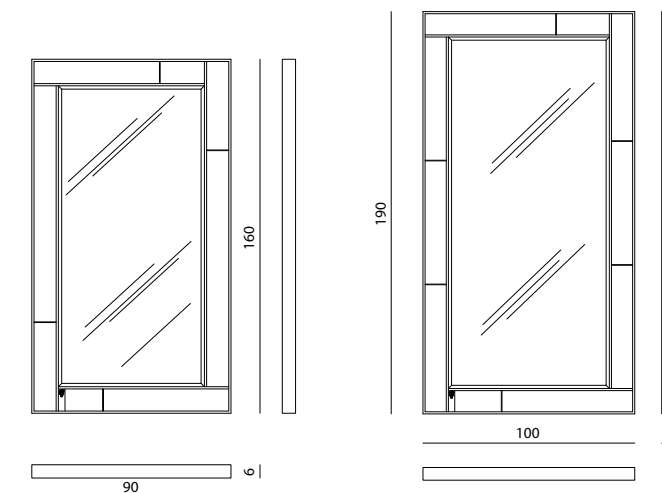

REBEL

SPECCHIO - MIRROR

Alessandro La Spada

Specchiera in metallo cromato con supporti tondi e ovali e acciaio. Una luce di cortesia con diffusore in acciaio a forma conica contenente un impianto a luce LED e paralume in onice retroilluminato realizzato da lastra a spessore ribassato. Corpo centrale con elettrificazione a bassa tensione e alimentatore posizionato nella staffa di attacco a parete. I supporti di specchi e diffusore sono collegati allo stelo centrale tramite bracci tubolari. Le parti in metallo sono disponibili nella selezione finiture metalliche. Sorgente luminosa a LED, max 10W. Peso 30 kg.

Mirror in chromed metal with round and oval supports in steel. Courtesy light with conical-shaped diffuser in steel with Led backlight lampshade in onyx, shaped from a milled stone slab. Central body with low voltage lighting, power supply positioned in the wall mounting bracket. Mirrors and diffuser positioned on tubular arms, structurally connected to central stem. Metal parts can be finished with any lacquer of the metal lacquer finish selection. LED light source, 10W max. Weight 30 kg.

vedi anche/see also REBEL lampadario-chandelier, REBEL applique-wall lamp, REBEL lampada da tavolo-table lamp

● [click here](#)

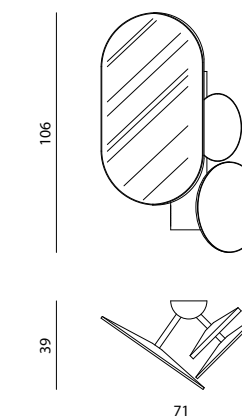



TALOS

SPECCHIERA - MIRROR
Samuele Mazza

Specchiera con cornice concava di forte spessore interamente rivestita in specchio bronzo bisellato. La cornice è interamente decorata con un profilo in acciaio inox. Le parti in metallo sono disponibili nella selezione finiture metalliche.

Mirror with thick reflex frame entirely coated in bevelled bronze mirror. The frame is decorated with a profile in stainless steel. Metal parts can be lacquered in any colour included in the metal finish selection.

● [click here](#)

WESTLEY

SPECCHIO - MIRROR
Steve Leung

Cornice in acciaio inox satinato con bordo conico. Illuminazione perimetrale a luci LED con accensione a sfioramento. Le parti in metallo sono disponibili nella selezione finiture metalliche satinato.

Frame in satinized stainless steel with conical border. LED lighting on perimeter with touch sensor. Metal parts available in the satinized metal finishing selection.

vedi anche/see also WESTLEY mobile trucco-make-up unit

● [click here](#)

WINDSOR

SPECCHIERA - MIRROR
Alessandro La Spada

Cornice formata da un fascia in vetro bisellato retrolaccato nero, racchiusa da un doppio profilato in ottone cromato. Specchio di sicurezza spessore 5 mm. I quattro angolari in vetro hanno logo sabbato e lavorato in foglia oro. Cornice interna con borchie in ottone cromato. Le parti in metallo sono disponibili nella selezione finiture metalliche.

Frame composed of a band in black lacquered bevelled glass closed by a double chromed brass profile. Security mirror 5 mm th. The four glass brackets have sandblasted logo worked in gold leaf. Internal frame with chromed brass studs. Metal parts can be lacquered in any colour included in the metal finish selection.

vedi anche/see also WINDSOR tavolo da pranzo-dining table, WINDSOR mobile trucco-make-up unit, WINDSOR cassetiera-chest of drawers for desk, WINDSOR scrittoio con cassetti-desk with drawers, WINDSOR vetrinetta-showcase, WINDSOR parete modulare-modular elements, WINDSOR armadio-wardrobe, WINDSOR cache-pot, WINDSOR vaso-vase, WINDSOR wellness room

● [click here](#)

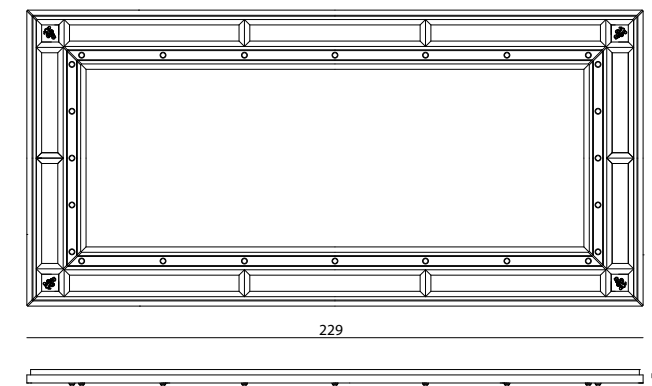
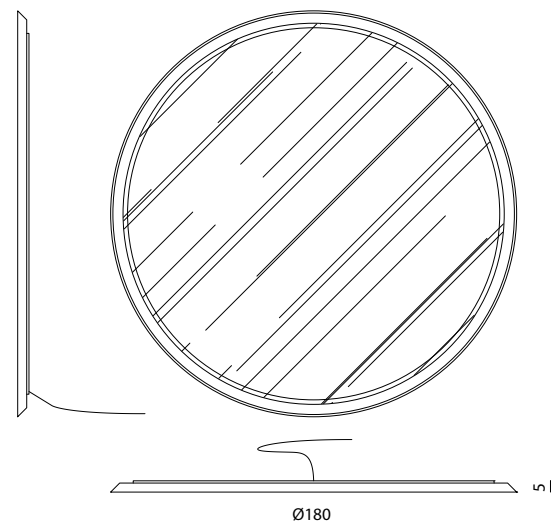
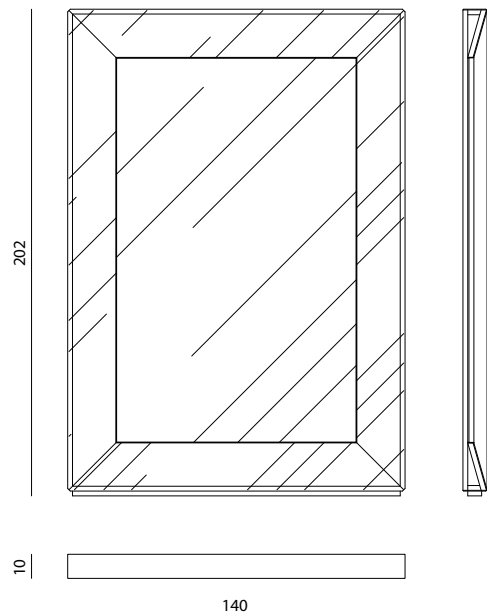



CHARADE

SPECCHIERA - MIRROR

Roberto Lazzeroni

Struttura in acciaio inox lucidato, tagliato al laser con inserti inox satinato. Retro in legno MDF laccato opaco. Borchie decorative con logo Visionnaire inciso in ottone cromato. Specchio bisellato. Le parti metalliche sono disponibili nella selezione finiture metalliche.

Structure in polished stainless steel, laser cut with satinized stainless steel inserts. Back in opaque lacquered MDF. Decorative studs with Visionnaire logo engraved in brass. Bevelled mirror. Metal parts available in the metal finishing selection.

● [click here](#)

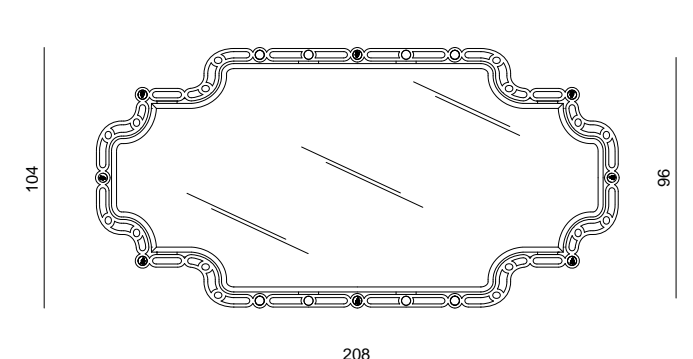

- click on the icons -



AKIRA p.394



ALCAZAR p.394



ALPHA p.395



BLU NOTE p.395



ARACEA p.396



BRANDO p.397



ETHAN ROUND p.398



FIRENZE p.398



FLORO p.399



KALGAN, BILBO
KAE p.399



BOREAL p.400



MADDY p.400

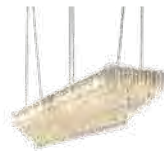

MAINZ p.401



MILANO p.401



NUAGES p.402



OWENS p.402



POLARIS p.403



PARADE p.404



REBEL p.404



ROCK p.405



ROMA p.405



SIRENES p.406



SPUTNIK- OXY p.406



SPUTNIK p.407

- click on the icons -

ICONICI - *ICONIC*



AMARILLI p.408



BRUNILDE p.408



ESMERALDA p.409



GALAHAD p.409



GALAHAD p.410



HOLLY p.410



SYLAR p.411



THOTH p.411



WOTAN p.412



AKIRA

LAMPADARIO - CHANDELIER

Alessandro La Spada

Lampadario a 12 oppure 16 luci con struttura in metallo lucidato o satinato, i bracci curvati sono fissati al fusto centrale tramite elementi in ottone massiccio. Portalampe in ottone tornito e luci G9 da 40W - 6W LED cad. con diffusore in vetro satinato. Paralumi concavi "a ventaglio" in tessuto stampa floreale o a campionario, con diffusore interno in moiré avorio. Le parti in metallo sono disponibili nella selezione finiture metalliche.

12 or 16 lights chandelier with polished or satin metal structure, the curved arms are fixed to the central stem by solid brass elements. Lampholders in turned brass and G9 40W - 6W LED bulbs with frosted glass diffuser. Concave "fan-shaped" lampshades in printed floral fabric or by samples with internal moiré diffuser. Metal parts available in the metal finishing selection.

vedi anche/see also AKIRA applique-wall lamp, AKIRA lampada da tavolo-table lamp, AKIRA ABAT-JOUR lampada da tavolo-table lamp, AKIRA lampada da terra-floor lamp

● click here

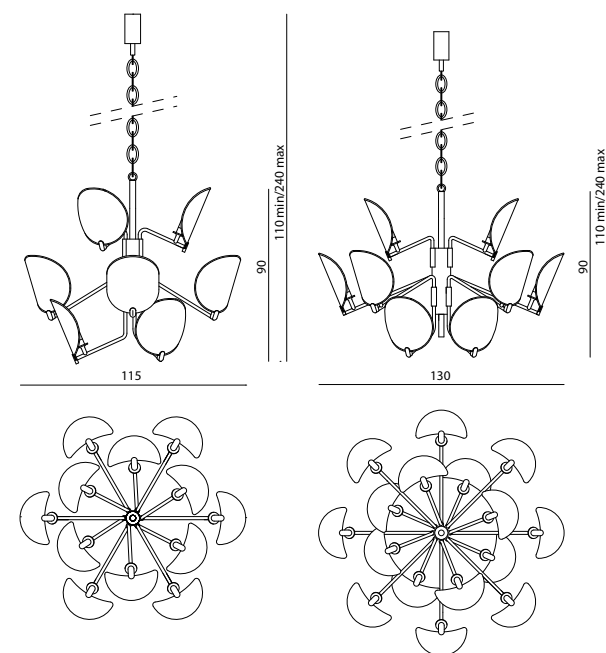

ALCAZAR

LAMPADARIO - CHANDELIER

Edoardo Pandolfo e Francesco Palù

Lampadario in vetro di Murano soffiato a mano composto da 15 elementi prismatici in vetro opalino soffiato di elevato spessore caratterizzato da una superficie irregolare e unica per ogni elemento, struttura metallica a stella con plafone in acciaio inox e tiranti in cavo d'acciaio regolabili in altezza. Impianto a 5 luci con attacco E27 60W - 8W LED cad., protetto da diffusore in pyrex. Peso 150 Kg.

Chandelier in hand-blown Murano glass composed by 15 large prism-shaped elements in blown opaline glass in high thickness, characterised by an irregular and unique surface for each element, star-shaped metal structure with ceiling-mounted fixture in stainless steel and cables in steel adjustable in height. Lighting system consisting of 5 bulbs with E27 connection 60W - 8W LED each, protected by a pyrex diffuser. Weight 150 kg.

● click here

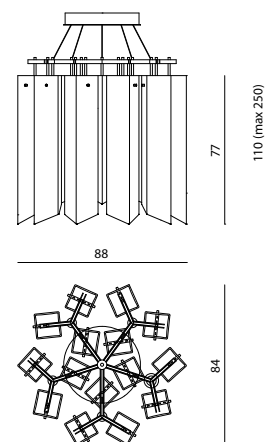

ALPHA

LAMPADARIO - CHANDELIER

Giuseppe Viganò

Lampadario in ottone e vetro soffiato. Struttura in tubi di ottone con finitura bicolore e bracciali di ottone massiccio scolpito. Diffusori sferici in vetro soffiato con finitura opalina satinata. Le parti in metallo sono disponibili nella selezione finiture metalliche. Sorgente luminosa a 4 luci G9 40W - 6W LED cad. Peso 10 kg.

Chandelier in brass and blown glass. Structure in tubular brass with bi-colour finish and rings in sculpted solid brass. Spherical diffuser in blown glass with satin opaline finish. Metal components can be finished with any lacquer of the metal lacquer finish selection. 4 lights G9 40W - 6W LED each. 10 kg weight.

vedi anche/see also ALPHA applique-wall lamp, ALPHA lampada da tavolo-table lamp, ALPHA piantana-floor lamp

● click here

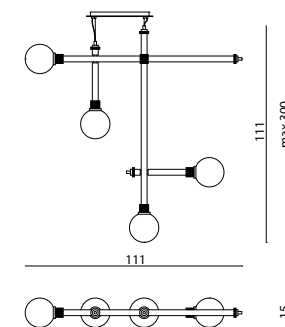

BLU NOTE

PLAFONIERA - CEILING LAMP

Marco Piva

Lampade a sospensione in vetro ambrato. Sorgente luminosa LED COB con diffusore in vetro satinato. Disponibili singolarmente e come plafoniere da tre e sei elementi con piastra metallica a soffitto e cavi regolabili in altezza. Le parti in metallo sono disponibili nella selezione finiture metalliche satinata. Plafoniera rettangolare a 6 elementi 16W, dimensioni 132x45 H. max 250 cm. Peso 36 kg. Plafoniera circolare a 3 elementi 16 W, dimensioni Ø50 H. max 250 cm. Peso 16 kg.

Suspension lamps in glass with amber finish. LED COB light source with internal diffuser satinized glass. Available individually or as ceiling lights of three and six elements with metal ceiling plate and height-adjustable cables. Metal parts available in the satinized metal finishing selection. Rectangular ceiling lamp, 6 elements 16W 132x45 H. max 250. Circular ceiling lamp, 3 elements 16 W Ø50 H. max 250 cm.

● click here

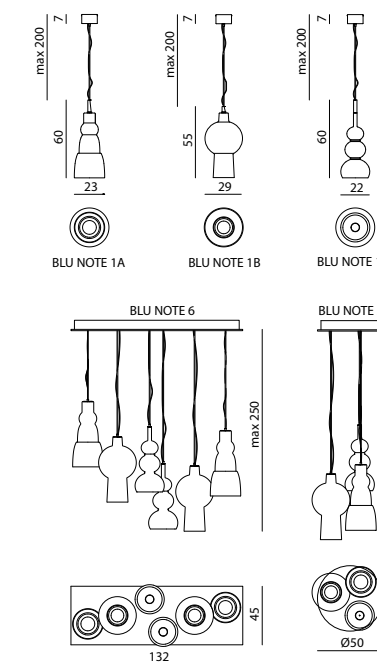



ARACEA

LAMPADARIO A SOSPENSIONE - CEILING LAMP

Gupica

Sospensione in ottone e alluminio satinato con quattro luci "a foglia" in acciaio inox. Sorgente luminosa lineare a LED. Tutte le "foglie" sono regolabili sia nell'inclinazione che nella rotazione. Disponibile nella selezione finiture metalliche, la faccia superiore della foglia in finitura lucida e quella inferiore satinata. Potenza assorbita 15W STRIP LED, peso 4 kg. Questo modello monta sorgenti luminose a LED a lunga durata integrate nella struttura della lampada, non sostituibili dall'utente.

Suspended lamp in brass and satin aluminium with four "leaf-shaped" lights in stainless steel. Linear LED light source. The rotation and the inclination of all the leaves can be adjusted. Available in any lacquer included in the metal finish selection, the upper face of the "leaf" in polished finish and the lower face in satin finish. Absorption power 15W STRIP LED, weight 4 kg. This model is equipped with long-life LED light sources integrated into the lamp structure, which cannot be replaced by the user.

vedi anche/see also ARACEA lampada da terra-floor lamp, ARACEA lampada cielo-terra-floor to ceiling lamp, ARACEA lampada da tavolo-table lamp, ARACEA applique-wall lamp

● click here

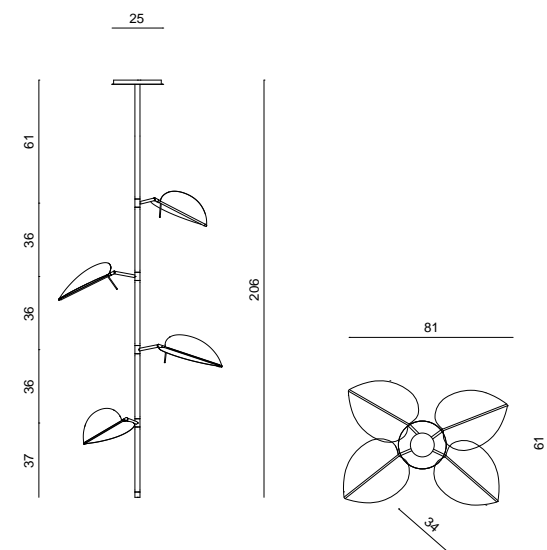

ARACEA

LAMPADA CIELO-TERRA - FLOOR TO CEILING LAMP

Gupica

Struttura in ottone e alluminio satinato con cinque luci "a foglia" in acciaio inox. Sorgente luminosa lineare a LED. Tutte le "foglie" sono regolabili sia nell'inclinazione che nella rotazione. Disponibile nella selezione finiture metalliche, la faccia superiore della foglia in finitura lucida e quella inferiore satinata. Potenza assorbita 20W, peso 6 kg. Questo modello monta sorgenti luminose a LED a lunga durata integrate nella struttura della lampada, non sostituibili dall'utente.

Structure in brass and satin aluminium with five "leaf-shaped" lights in stainless steel. Linear LED light source. The rotation and the inclination of all the leaves can be adjusted. Available in any lacquer included in the metal finish selection, the upper face of the "leaf" in polished finish and the lower face in satin finish. Absorption power 20W, weight 6 kg. This model is equipped with long-life LED light sources integrated into the lamp structure, which cannot be replaced by the user.

vedi anche/see also ARACEA lampadario a sospensione-ceiling lamp, ARACEA lampada da terra-floor lamp, ARACEA lampada da tavolo-table lamp, ARACEA applique-wall lamp

● click here

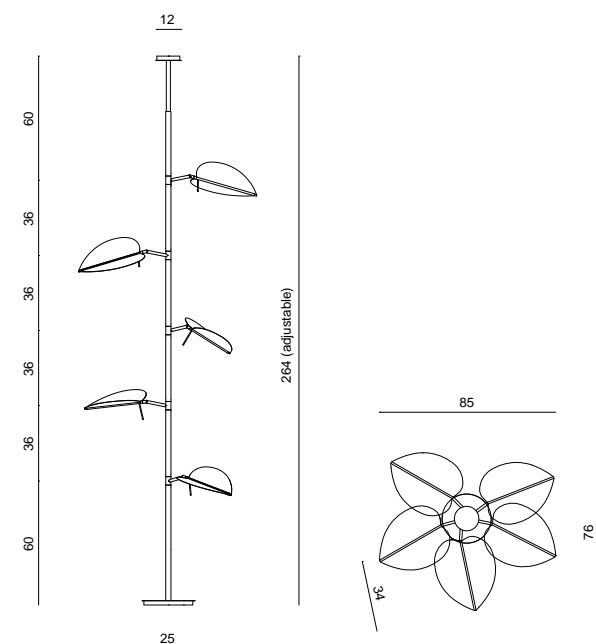

BRANDO

LAMPADARIO OTTAGONALE - OCTAGONAL CHANDELIER

Samuele Mazza

Struttura portante in acciaio e ottone con finitura satinata cromo o oro. Paralumi in Onice Avorio sp. 8 mm sospesi a formare una figura sfaccettata e illuminati da un impianto di 13 luci G9 max 40W - 6W LED cad. Assorbimento max 520 W, peso 25 kg. Sospensione su catena a maglie ottagonali.

Main structure in steel and brass with satinized chromed or gold finishings. Lampshades in Ivory Onyx, 8 mm in width, creating a multifaceted effect. Lighting system for 13 light bulbs G9 max 40W - 6W LED each. Max 520W in total, weight 25 kg. Two-point suspension with octagonal link chains.

vedi anche/see also BRANDO applique-wall lamp, BRANDO piantana-floor lamp

● click here

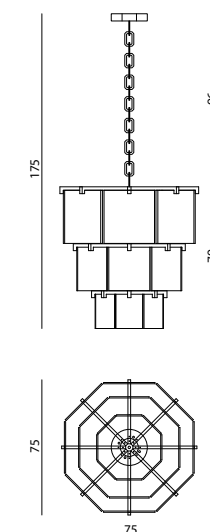

BRANDO

LAMPADARIO - CHANDELIER

Samuele Mazza

Struttura portante in acciaio e ottone con finitura satinata cromo o oro. Paralumi in Onice Avorio sp. 8 mm sospesi a formare una figura sfaccettata e illuminati da un impianto di 32 luci G9 max 40W - 6W LED cad. peso 55 kg. Sospensione su due catene a maglie ottagonali. Disponibile anche nella versione a 26 luci G9 max 40W - 6W LED cad., peso 45 kg.

Main structure in steel and brass with satinized chromed or gold finishings. Suspended lampshades in Ivory Onyx, 8 mm in width, creating a multifaceted effect. Lighting system for 32 light bulbs G9 max 40W - 6W LED each. Weight 55 kg. Two-point suspension with octagonal link chains. Available in version with 26 light bulbs G9 max 40W - 6W LED each. Weight 45 kg.

vedi anche/see also BRANDO applique-wall lamp, BRANDO piantana-floor lamp

● click here

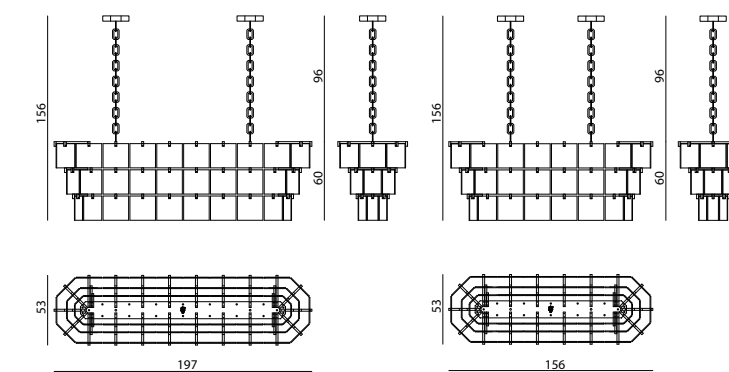



ETHAN ROUND

LAMPADARIO - CHANDELIER

Alessandro La Spada

Lampadario in vetro su tre livelli sovrapposti a diametro decrescente. Telaio in acciaio satinato e corpo centrale composto da un tamburo di canne in vetro pirex trasparente, sospesi con cavi in acciaio regolabili in altezza (H. max 3,40 m). Impianto luci con 6 sorgenti LED max 240W dimmerabile, peso 90 kg. Questo model lo monta sorgenti luminose a LED a lunga durata integrate nella struttura della lampada, non sostituibili dall'utente. Le parti in metallo sono disponibili nella selezione finiture metalliche satiniate.

Chandelier in glass on three levels in decreasing diameter. Frame in satinized steel and central main body made of tubes of transparent pyrex, hung with adjustable steel wires (maximum height 3,40 m). Dimmable lighting system with 6 LED lights max 240W, weight 90 kg. This model is equipped with long-life LED light sources integrated into the lamp structure, which cannot be replaced by the user. Metal parts can be lacquered in any colour included in the satinized metal finish selection.

vedi anche/see also ETHAN applique-wall lamp, ETHAN lampada da tavolo-table lamp

● click here

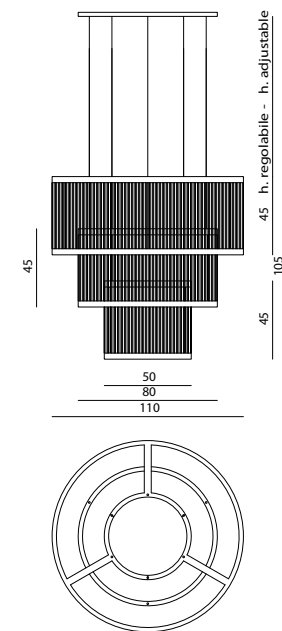

FIRENZE

LAMPADARIO - CHANDELIER

Armando Bruno - Alberto Torres

Lampadario sferico in vetro soffiato trasparente con piatto decorativo interno in marmo e diffusore centrale in vetro soffiato opalino. Struttura portante in acciaio cromato. Le parti in metallo lucido sono disponibili nella selezione finiture metalliche. Sorgente luminosa a lampada G9 max 40W - 7W LED, peso 19 kg.

Spherical chandelier in clear blown glass with decorative internal plate in marble and central diffuser in opaline blown glass. Main structure in chromed steel. Components in shiny metal can be finished with any lacquer of the shiny metal lacquer finish selection. G9 max 40W - 7W LED light source, 19 kg weight.

● click here

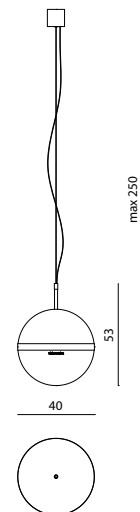

FLORO

LAMPADARIO - CEILING LAMP

Alessandro La Spada

Struttura in ottone e acciaio, disponibile a 4 o 6 elementi luminosi in vetro soffiato con dispersione di foglia d'oro incastonati in un bracciale metallico. Stelo e rosone in acciaio. Impianto a 8 luci LED E14 8W cad, peso 22 Kg (versione a 4 elementi); impianto a 12 luci LED E14 8W cad, peso 36 Kg (versione a 6 elementi). Le parti metalliche sono disponibili nella selezione finiture metalliche lucide.

Structure in brass and steel, available with 4 or 6 light elements in blown glass containing gold leaf particles, encased in a metal bracelet. Stem and ceiling cup in steel. Lighting system consists of 8 LED bulbs E14 8W each, weight 22 Kg (4 elements version); 12 LED bulbs E14 8W each, weight 36 Kg (6 elements version). Metal parts can be lacquered in any colour of the polish metal finish selection.

vedi anche/see also FLORO lampada da terra-floor lamp, FLORO lampada da tavolo-table lamp, FLORO applique-wall lamp

● click here

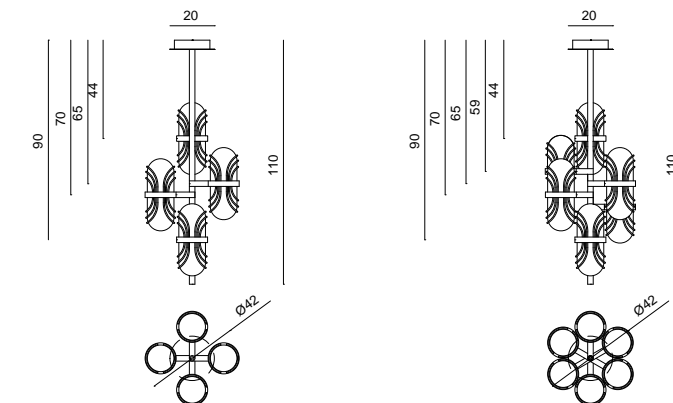

KALGAN - BILBO - KAEL

PLAFONIERE - CEILING LAMPS

Marco Piva

Lampade a sospensione in vetro con trattamento superficiale di vaporizzazione metallica di ottone antico, titanio sfumato e rame brunito. Sorgente luminosa a LED - COB 9W con diffusore interno in pirex satinato. Disponibili singolarmente. Peso 25 Kg. Le parti in metallo sono disponibili nella selezione finiture metalliche satiniate. Sorgenti luminose a LED a lunga durata integrate nella struttura della lampada, non sostituibili dall'utente.

Suspension lamps in glass with surface treatment of metal vaporization of antique brass, titanium fade and dark copper. LED - COB 9W light source with internal diffuser in satin Pyrex. Available individually. Weight 25 Kg. Metal parts available in the satinized metal finishing selection. This model is equipped with long-life LED light sources integrated into the lamp structure, which can not be replaced by the user.

● click here

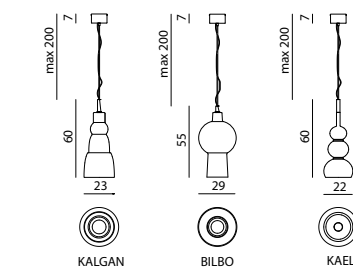



BOREAL

PLAFONIERE - CEILING LAMPS

Marco Piva

Lampade a sospensione in vetro con trattamento superficiale di vaporizzazione metallica di ottone antico, titanio sfumato e rame brunito. Sorgente luminosa a LED - COB 9W con diffusore interno in pirex satinato. Disponibili come plafoniere da tre e nove elementi con piastra metallica a soffitto e cavi regolabili in altezza. Le parti in metallo sono disponibili nella selezione finiture metalliche satiniate.

Plafoniera rettangolare a 9 elementi cm 190x45 H. max 250. Peso 42 Kg. Plafoniera circolare a 3 elementi cm 50 H. max 250. Questo modello monta sorgenti luminose a LED a lunga durata integrate nella struttura della lampada, non sostituibili dall'utente.

Suspension lamps in glass with surface treatment of metal vaporization of antique brass, titanium fade and dark copper. LED - COB 9W light source with internal diffuser in satin Pyrex. Available as ceiling lights of three and nine elements with metal ceiling plate and height-adjustable cables. Metal parts available in the satinized metal finishing selection. Rectangular ceiling lamp, 9 elements 190x45 H. max 250 cm. Weight 42 Kg. Circular ceiling lamp, 3 elements 50 H. max 250 cm. This model is equipped with long-life LED light sources integrated into the lamp structure, which can not be replaced by the user.

● click here

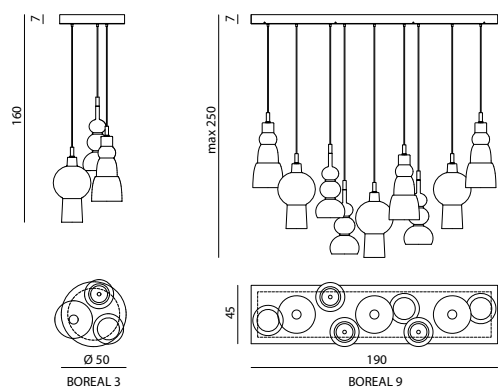

MADDY

LAMPADA A SOSPENSIONE - SUSPENSION LAMP

Alessandro La Spada

Lampada a sospensione in marmo lavorato da massello e lucidato a mano, con ghiera in ottone rigato e cavo di supporto in acciaio integrato nel cavo di alimentazione. Portalampane GU10 max 40W - 6W LED cad. Peso 10 Kg.

Hanging lamp in marble obtained from solid marble and hand-polished, with ring in striped brass and steel support cable integrated in the power cord. Bulb GU10 max 40W - 6W LED each. Weight 10 Kg.

● click here

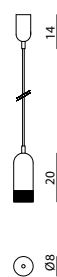

MAINZ

PLAFONIERA - CEILING LAMP

Samuele Mazza

Struttura in acciaio cromato adornata con pendenti in cristallo a triedro con taglio a 45° disposti a piramide. Cablaggio predisposto per luci E27 60W - 8W LED cad. (nella versione 200x50 cm, nr. 12 lampadine, nella versione 250x50 cm, nr. 16 lampadine). Peso 200 kg (versione L. 250 cm). Peso 150 kg (versione L. 200 cm).

Structure in chromed steel decorated with trihedral crystal pendants with 45° cut, disposed as pyramid. Wiring: E 27 bulbs 60W - 6W LED each. (in the version 200x50 cm, nr. 12 bulbs, in the version 250x50 cm, nr. 16 bulbs). Weight 200 kg (version L. 250 cm). Weight 150 kg (version L. 200 cm).

● click here

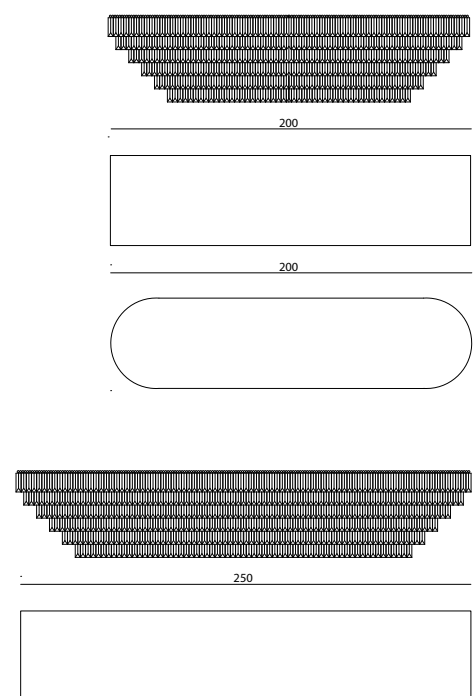

MILANO

LAMPADARIO - CHANDELIER

Armando Bruno - Alberto Torres

Lampada a sospensione in marmo e acciaio. Struttura superiore in metallo con lavorazione "rigata" in bassorilievo e corpo centrale in marmo massello. Diffusore a prisma in policarbonato massello lucido con finitura interna opalina satinata. Sorgente luminosa a COB-LED 8W max. Le parti in metallo sono disponibili nella selezione finiture metalliche, il corpo centrale in marmo è disponibile monocromatico o a due colori alternati. Peso: versione piccola 7 kg, versione grande 10 kg, versione a tre elementi 24 kg.

Suspension lamp in marble and steel. Upper part in metal with low-relief 'stripes' decoration and central body in solid marble. Prismatic diffuser in shiny solid polycarbonate, with satin opaline internal finish. COB-LED light 8W max. Metal parts available in any lacquer of the metal lacquer finish selection. Central body in one or two marbles. Weight: small version 7 kg, large version 10 kg, three-element version 24 kg.lection. Central body in one or two marbles.

vedi anche/see also MILANO applique-wall lamp, MILANO lampada da tavolo-table lamp, MILANO piantana-floor lamp

● click here

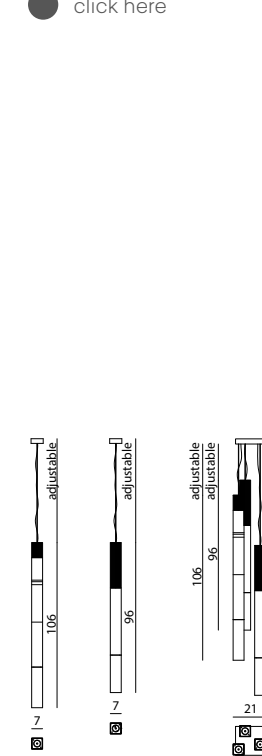



NUAGES

LAMPADA A SOSPENSIONE - SUSPENSION LAMP

Marta Naddeo

Sospensione in vetro soffiato e metallo. Rosone di attacco a soffitto in acciaio inox con dieci punti luce in vetro soffiato trasparente ad alto spessore, di diverse dimensioni a texture "balloton" e "rigato". I vetri, a sfera schiacciata, ospitano una sorgente a LED COB CRI90 da 5W ognuno con diffusore interno e copertura in metallo con stelo decorativo. I punti luce sono sospesi da un cavo in acciaio a lunghezza regolabile. Le parti in metallo sono disponibili nella selezione finiture metalliche. Peso: 24 kg.

Suspended lamp in blown glass and metal. Ceiling rose in stainless steel with ten light points in thick transparent blown glass of different sizes with "balloton" and "ribbed" textures. The flattened spherical glass houses a 5W COB CRI90 LED source each with an internal diffuser and metal cover with a decorative stem. The light points are suspended by a steel cable with adjustable length. The metal parts are available in a selection of metal finishes. Weight: 24 kg

● [click here](#)

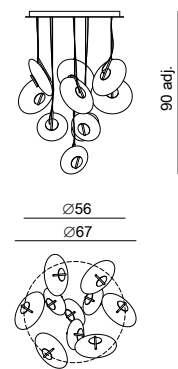

OWENS

LAMPADARIO - CHANDELIER

Philippe Montels

Struttura portante in alluminio. Rivestimento a drappi di placche di alluminio. Fissaggio a soffitto tramite cavi in acciaio e plafone in acciaio inox sp. 1,5 e cavi in acciaio 2 mm. 16 luci G9 40W - 6W LED cad. Scaglie alluminio naturale. Opzione: scaglie alluminio champagne e cristalli Swarovski. Peso 15 kg.

Aluminium supporting structure covered with drapes of aluminium plates. Fixed to the ceiling by steel cables and stainless steel ceiling cap 1,5 thick and 2 mm steel cables, 16 lights G9 40W - 6W LED each. Natural aluminium scales. Option: champagne aluminium scales and Swarovski crystals. Weight 15 kg.

OWENS XL

LAMPADARIO - CHANDELIER

Struttura portante in alluminio. Rivestimento a drappo formato da scaglie di alluminio naturale. Fissaggio a soffitto tramite cavi in acciaio e plafone in acciaio inox. 24 luci 40W - 6W LED cad. In opzione scaglie alluminio champagne e cristalli Swarovski. Peso 25 kg.

Main structure in aluminium covered with a drape of aluminium plates in natural shade. Ceiling fixing through steel cables and upper part in stainless steel with 24 bulbs max 40W - 6W each. Available also with the aluminium plates in champagne colour and Swarovski crystals. Weight 25 kg.

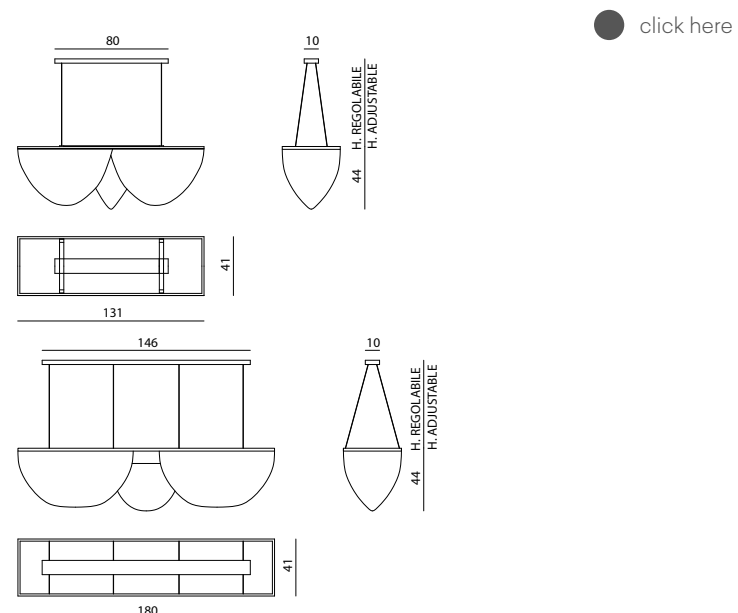

POLARIS

LAMPADARIO - CHANDELIER

Alessandro La Spada

Lampadario a doppia corona composto da 22 elementi curvi in alluminio lucidato nella parte esterna e satinato nella parte interna, con diffusori in marmo retroilluminato con lavorazione del bordo a "spacco vivo" tagliato in continuità di vena. Illuminazione a LED COB. I diffusori sono ancorati a un anello portante sostenuto da tiranti in cavo di acciaio regolabili in altezza. Le parti metalliche sono disponibili nella selezione finiture metalliche. Peso 75 kg, potenza complessiva 66W (3W cad.).

Chandelier with circular shape consisting of 22 curved elements in polished aluminium on the outside and satin-finished aluminium on the inside, with diffusers in backlit vein-cut marble with raw cut edges. Lighting system: LED COB. Diffusers anchored to the supporting ring-shaped structure by means of steel wired with adjustable height. Metal parts available in any lacquer of the metal finish selection. Weight 75 kg, total watt 66W (3W each).

vedi anche/see also POLARIS applique-wall lamp, POLARIS lampada da tavolo-table lamp, POLARIS abat-jour

● [click here](#)

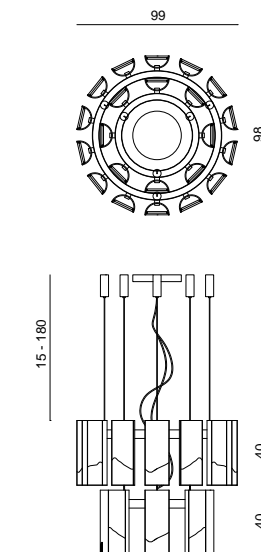

POLARIS

LAMPADARIO - CHANDELIER

Alessandro La Spada

Lampadario a corona composto da 14 elementi curvi in alluminio lucidato nella parte esterna e satinato nella parte interna, con diffusori in marmo retroilluminato con lavorazione del bordo a "spacco vivo" tagliato in continuità di vena. Illuminazione a LED COB. I diffusori sono ancorati a un anello portante sostenuto da tiranti in cavo di acciaio regolabili in altezza. Le parti metalliche sono disponibili nella selezione finiture metalliche. Peso 45 kg, potenza complessiva 42W (3W cad.). Disponibile anche in versione da 8 elementi, peso 25 kg, potenza complessiva 24 W.

Chandelier with circular shape consisting of 14 curved elements in polished aluminium on the outside and satin-finished aluminium on the inside, with diffusers in backlit vein-cut marble with raw cut edges. Lighting system: LED COB. Diffusers anchored to the supporting ring-shaped structure by means of steel wired with adjustable height. Metal parts available in any lacquer of the metal finish selection. Weight 45 kg, total watt 42W (3W each). Also available in 8-element version, weight 25 kg, total watt 24 W.

vedi anche/see also POLARIS applique-wall lamp, POLARIS lampada da tavolo-table lamp, POLARIS abat-jour

● [click here](#)

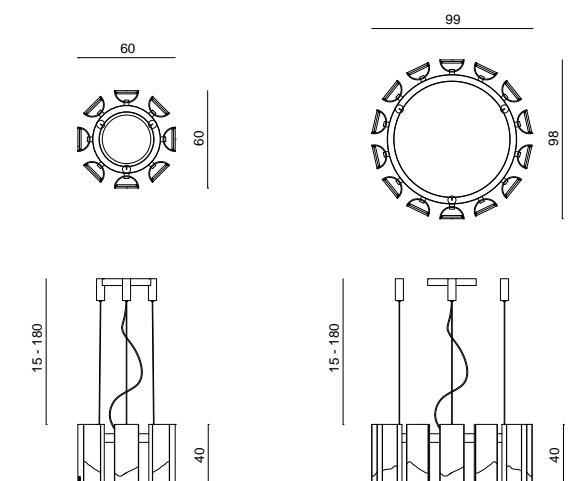



PARADE

LAMPADA A SOSPENSIONE - SUSPENSION LAMP

Studio Pepe

Sospensione tubolare con diffusori in vetrofusione. Barra portante in acciaio con doppia sorgente luminosa a LED, superiore e inferiore. Cinque diffusori irregolari in vetrofusione da 6 mm parzialmente sovrapposti realizzati manualmente e trattati a forno, attraversati dal taglio dalla luce. Cavi portanti in acciaio sp. 2 mm con rosone di alimentazione singolo. Assorbimento 30W, peso 35 kg. Parti metalliche disponibili nella selezione finiture metalliche. Questo modello monta sorgenti luminose a LED a lunga durata integrate nella struttura della lampada, non sostituibili dall'utente.

Tubular suspended lamp with fused glass diffusers. Steel support bar with double LED light source (top and bottom). Five irregular, partially overlapping, 6 mm glassfusion diffusers made by hand and oven-treated, through which the light is cut. 2 mm thick steel support cables with single feed rose. Absorption 30W, weight 35 kg. Metal parts available in the metal finish selection. This model mounts long-life LED light sources integrated in the lamp structure, not replaceable by the user.

vedi anche/see also PARADE applique-wall lamp

● click here

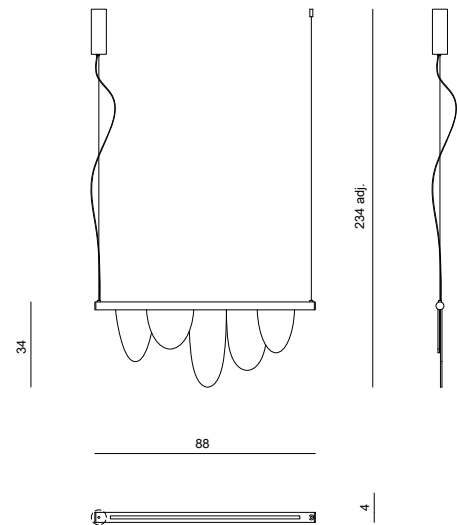

REBEL

LAMPADARIO - CHANDELIER

Alessandro La Spada

VERSIONE BIG - Lampadario a 18 luci in metallo cromato con diffusori in onice e acciaio. Struttura portante in tubo metallico con elettrificazione a bassa tensione e alimentatore posizionato nel rosone. Diffusori in acciaio a forma conica contenenti un impianto a luce LED e paralume in onice retroilluminato realizzato da lastra a spessore ribassato. I diffusori sono collegati allo stelo centrale tramite bracci tubolari. Le parti in metallo sono disponibili nella selezione finiture metalliche. Sorgente luminosa a STRIP LED, max 240W. Peso 90 kg. Disponibile in VERSIONE REGULAR - Lampadario a 10 luci, sorgente luminosa a STRIP LED, max 140W. Peso 50 kg.

BIG VERSION - Chandelier with 18 lights in chromed metal with diffusers in onyx and steel. Main structure in tubular metal, low voltage lighting, power supply positioned in the ceiling rose. Conicalshapeddiffusers in steel with Led backlight lampshade in onyx, shaped from a milled stone slab. Diffusers positioned on tubular arms, structurally connected to central stem. Metal parts can be finishedwith any lacquer of the metal lacquer finish selection. STRIP LED light source, 240W max. Weight 90 kg. Available in REGULAR VERSION - Chandelier with 10 STRIP LED light source, 140W max. Weight 50 kg.

vedi anche/see also REBEL specchio-mirror, REBEL applique-wall lamp, REBEL lampada da tavolo-table lamp

● click here

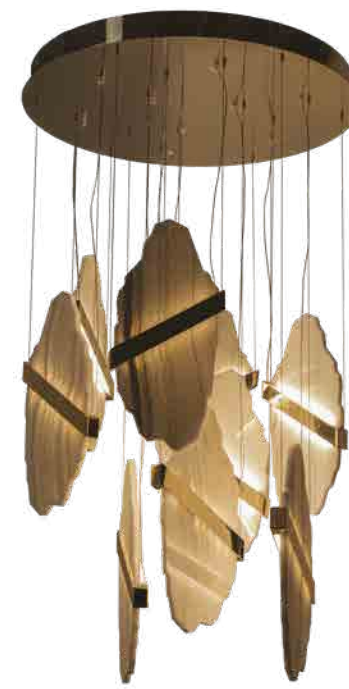
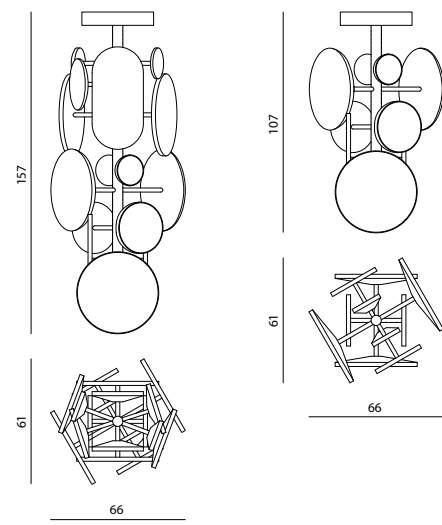

ROCK

LAMPADARIO - CHANDELIER

Alessandro La Spada

Lampadario disponibile a 3, 6 o 9 luci. Corpi illuminanti a LED contenuti in barre di acciaio che sostengono il diffusore in onice di forma irregolare. I corpi illuminanti sono sospesi tramite tiranti in acciaio regolabili singolarmente in altezza. Rosone a soffitto contenente driver e cablaggio con copertura in acciaio. Le parti in metallo sono disponibili nella selezione finiture metalliche. Potenza e peso: 3 luci: 32W, peso 30 Kg; 6 luci: 65W, peso 55 Kg; 9 luci: 100W, peso 70 Kg. Questo modello monta sorgenti luminose a LED a lunga durata integrate nella struttura della lampada, non sostituibili dall'utente.

Chandelier available with 3, 6 o 9 lights. LED lights inside steel bars which sustain the Onyx light diffusers with irregular shapes. The lighting bodies are suspended by means of tie rods in steel individually adjustable in height. Ceiling cup contains driver and wiring with steel cover. Metal parts available in any finish included in the metal finish selection. Power and weight: 3 lights: 32W, 30 kg; 6 lights: 65W, 55 kg; 9 lights: 100W, 70 kg. This model is equipped with long-life LED light sources integrated into the lamp structure, which cannot be replaced by the user.

vedi anche/see also ROCK applique-wall lamp, ROCK lampada da tavolo-table lamp

● click here

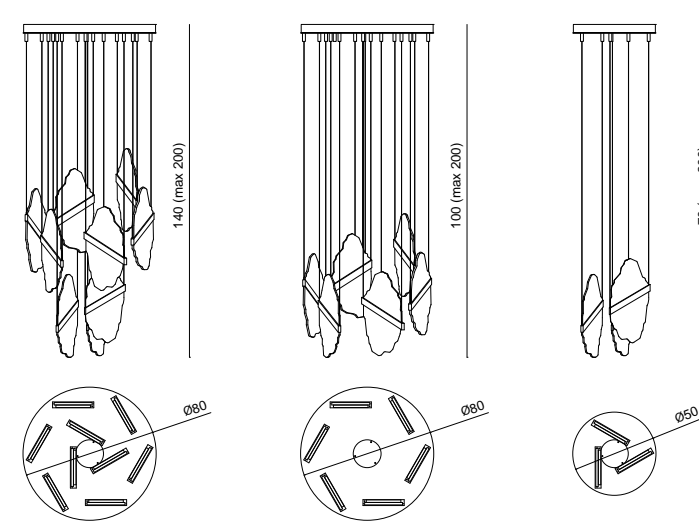

ROMA

LAMPADA A SOSPENSIONE - SUSPENSION LAMP

Armando Bruno - Alberto Torres

Lampada a sospensione in marmo e acciaio. Struttura in metallo lucido con lavorazione "rigata" in bassorilievo e corpo centrale in lastra di marmo lucidata su tutti i lati e lavorata internamente per il passaggio del cablaggio elettrico. Diffusore sferico in vetro di Murano soffiato con finitura bianco opalino satinato. Portalampada e rosone con calotta metallica e collegamento al rosone tramite cavo in acciaio. Le parti decorative in metallo sono disponibili nella selezione finiture metalliche. Sorgente luminosa E14 40W - 6W LED cad, peso 9 kg.

Suspension lamp in marble and steel. Structure in polished metal with low-relief stripes decoration; central body shaped from slab of polished marble, internally carved to route cables. Spherical diffuser in blown Murano glass with satin white opaline finish. Lamp holder and ceiling rose with metal cup, connected to the ceiling rose with a steel wire. Decorative metal elements can be finished with any lacquer of the metal lacquer finish selection. Light E14 40W - 6W LED each, 9 kg weight.

vedi anche/see also ROMA lampada da tavolo-table lamp

● click here

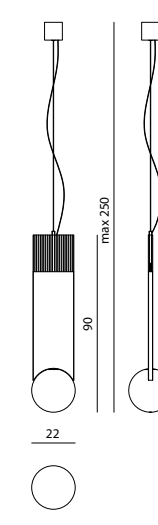



SIRENES

LAMPADA A SOSPENSIONE - SUSPENSION LAMP

Marta Naddeo

Sospensione multipla con luci in vetro soffiato e metallo. Elementi soffiati in vetro trasparente con texture "corteccia", di diverse dimensioni a base quadrata con lato di 10 e 14 cm. I diffusori si appoggiano su elementi metallici a piramide in acciaio inox contenenti una sorgente LED COB CRI90 (7W cad.). Cavo di sostegno in acciaio inox di lunghezza regolabile (max 300 cm totali) con rosone a soffitto. Peso 21 kg.

Multiple suspended lamp with blown glass and metal lights. Blown clear glass elements with 'bark' texture, in different sizes with a square base with 10 and 14 cm sides. The diffusers rest on stainless steel metal pyramid elements containing a COB CRI90 LED source (7W each). Stainless steel support cable of adjustable length (max. 300 cm total) with ceiling rose. Weight 21 kg.

● [click here](#)

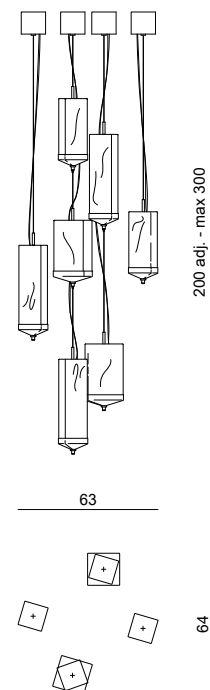

SPUTNIK-OXY

LAMPADA A SOSPENSIONE - SUSPENSION LAMP

Marco Draga & Aurel

Lampadario composto da 10 steli in acciaio tubolare terminanti con paralumi diffusori romboidali che racchiudono un diffusore decagonale in metallo e vetro fuso artistico. Le sorgenti luminose a LED sono disposte nel perimetro del diffusore. Le parti in metallo sono disponibili nella selezione finiture metalliche satiniate. Predisposto per attacco a plafoniera oppure tramite rosone e catena: assorbimento 55W, peso 35 Kg. Questo modello monta sorgenti luminose a LED a lunga durata integrate nella struttura della lampada, non sostituibili dall'utente.

Chandelier made of 10 tubular steel stems ending in rhomboidal diffuser shades which hold a decagonal metal and cast art glass diffuser. LED light sources are distributed around the perimeter of the diffuser. The metal parts are available in a selection of satinized metal finishes. Predisposed for ceiling fixing or by ceiling rose and chain: absorption 55W, weight 35 Kg. This model mounts long-life LED light sources integrated in the structure of the lamp, which cannot be replaced by the user.

vedi anche/see also SPUTNIK sospensione-suspension lamp, applique-wall lamp

● [click here](#)

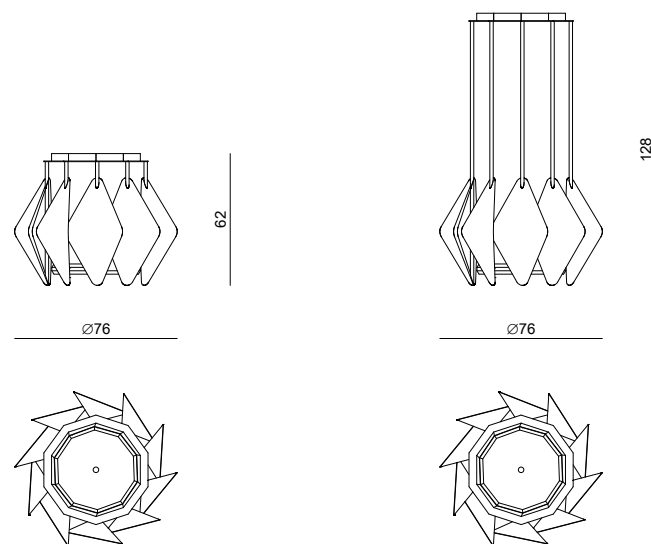

SPUTNIK

LAMPADARIO - CHANDELIER

Draga&Aurel

Lampadario composto da 16 elementi in acciaio tubolare contenenti 16 oppure 24 sorgenti LED e paralumi diffusori romboidali deformati a freddo in finitura lucida. Le parti in metallo sono disponibili nella selezione finiture metalliche lucide. Predisposto per attacco a plafoniera oppure tramite rosone e catena: altezza 94 cm per la versione a 16 luci estendibile fino a 349 cm, assorbimento 44W, peso 42 Kg. Altezza 142 cm per la versione a 24 luci estensibile fino a 397 cm, assorbimento 70W, peso 46 Kg. Questo modello monta sorgenti luminose a LED a lunga durata integrate nella struttura della lampada, non sostituibili dall'utente.

Chandelier composed by 16 elements in tubular steel containing 16 or 24 LED lights and cold cured rhombus-shaped lampshades with polish finish. Metal parts available in any finish included in the metal finish selection. Equipped with ceiling fitting or with ceiling cup and chain: height 94 cm for version with 16 lights, adjustable up to 349 cm. Absorption power 44W, weight 42 kg. Height 142 cm for the version with 24 lights, adjustable up to 397 cm. Absorption power 70W, weight 46 kg. This model is equipped with long-life LED light sources integrated into the lamp structure, which can not be replaced by the user.

vedi anche/see also SPUTNIK applique-wall lamp, SPUTNIK-OXY lampada a sospensione-suspension lamp

● [click here](#)

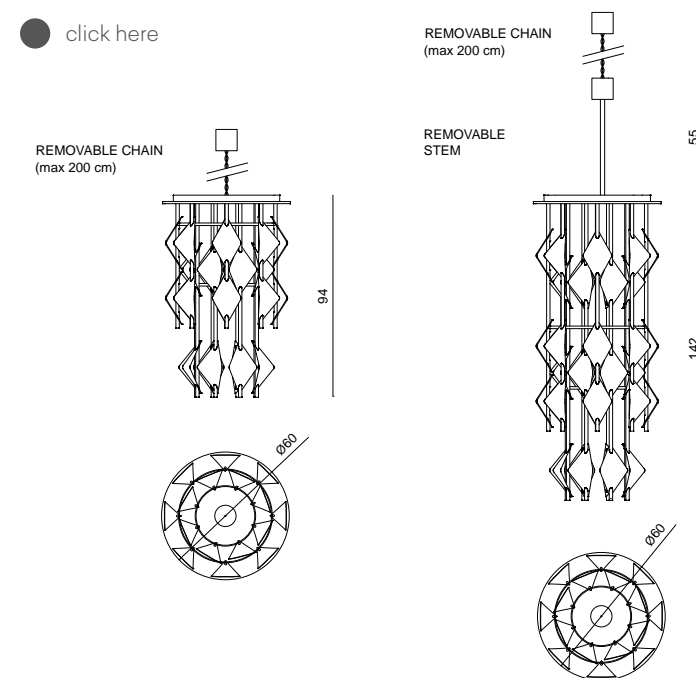

SPUTNIK

SOSPENSIONE - SUSPENSION LAMP

Draga&Aurel

Sospensione composta da quattro elementi in acciaio tubolare contenenti 18 sorgenti LED e paralumi diffusori romboidali deformati a freddo in finitura lucida. Le parti in metallo sono disponibili nella selezione finiture metalliche lucide. Assorbimento 55W, peso 19 Kg. Questo modello monta sorgenti luminose a LED a lunga durata integrate nella struttura della lampada, non sostituibili dall'utente.

Suspended lamp composed by four elements in tubular steel containing 18 LED lights and cold cured rhombus-shaped lampshades with polish finish. Metal parts available in any finish included in the metal finish selection. Absorption power 55W, weight 19 kg. This model is equipped with long-life LED light sources integrated into the lamp structure, which can not be replaced by the user.

vedi anche/see also SPUTNIK applique-wall lamp, SPUTNIK-OXY lampada a sospensione-suspension lamp

● [click here](#)

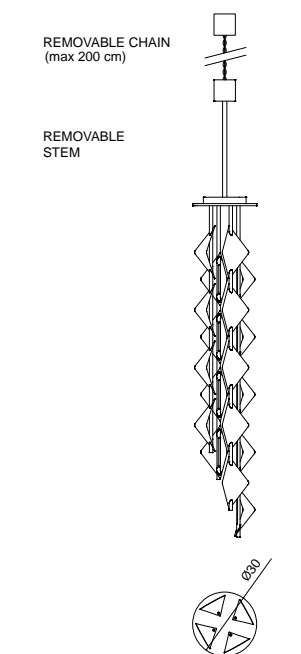



AMARILLI

LAMPADARIO - CHANDELIER

Alessandro La Spada

Stelo con tornerie in alluminio cromo o lacca oro. Tubolari in ottone trafalato "torchon" anticato. Decorazioni taglio laser ottone anticato. 9 lampade E27 60W - 8W LED cad. Paralumi a lobi in seta nera e interno in materiale riflettente oro. Peso 40 kg. Disponibile anche con paralumi con grafica "Adventures in the sea" e "Flowers&Raven".

Stem with turnings in chromed or gold lacquer aluminium. Tubulars in drawn antique brass "torchon". Laser-cut antique brass decorations. 9 lamps E27 60W - 8W LED each. Lampshade with lobes in black silk and internal in gold reflective material. Weight 40 kg. Available with lampshades with "Adventures in the sea" and "Flowers & Raven" coverings.

● click here

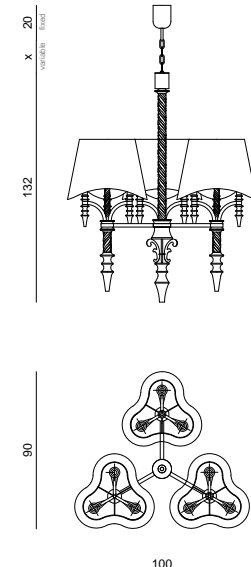

BRUNILDE

LAMPADARIO - CHANDELIER

Alessandro La Spada - Samuele Mazza

Coni ricurvi e lancia centrale in ottone cromato; particolari in alluminio tornito. Paralumi ovali, tronco cono in seta crema o in opzione, in seta nera e interno in materiale riflettente oro. Versione con tre coppie di corni: 6 luci E27 75W - 10W LED cad. Peso totale 30 kg. Versione con sei coppie di corni: 12 luci E27 75W - 10W LED cad. Peso totale 70 kg. Disponibili in versione CONTRACT con struttura e particolari in metallo cromato.

Curved cones and central bar in chromed brass, particulars in turned steel. Oval truncated cone lampshades in cream silk, or option, black silk and gold inner reflective material. Version with 3 couples of horns: 6 bulbs E27 75W - 10W LED each, total weight 30 kg. Version with 6 couples of horns: 12 bulbs E27 75W - 10W LED each, total weight 70 kg. Available also CONTRACT versions with structure and particulars in chromed metal.

vedi anche/see also BRUNILDE applique-wall lamp

● click here

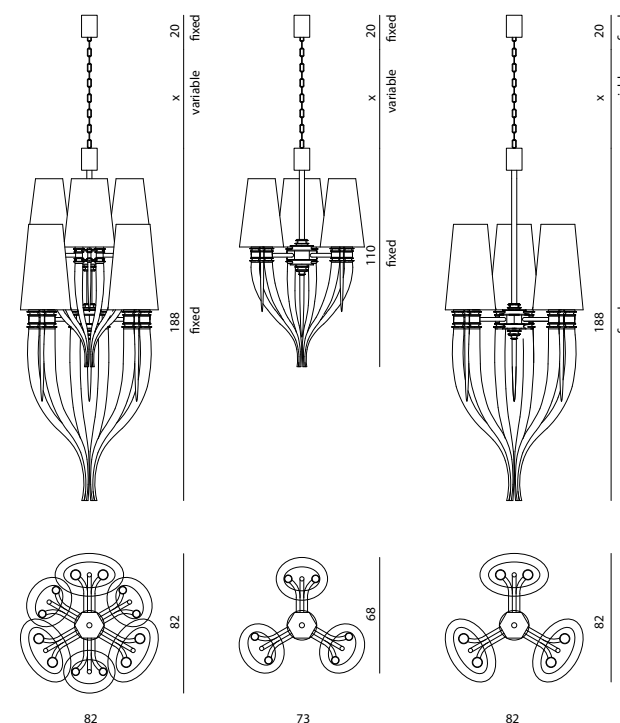

ESMERALDA

LAMPADARIO - CHANDELIER

Alessandro La Spada

Struttura in ottone finitura lucida color oro, corna tronco coniche in ottone laccato, elemento in cristallo a piombo soffiato e molato, con lavorazione bugnata, finitura acidata. Paralume in tessuto nero con l'interno oro lucido, per tutte le versioni le lampadine sono E27 60W - 8W LED cad; per la versione lampadario ci sono 9 lampadine. Peso kg 40. Disponibile anche con paralumi con grafica "Adventures in the sea" e "Flowers&Raven".

Structure in brass in gold shiny finishing. Half-truncated horns in lacquered brass. Lead crystal element, blown and grinded, with studded shape and frosted finishing. Lampshade in black fabric with gold internal decoration. For all the versions, the bulbs needed are E27 60W - 8W LED each: Chandelier - 9 bulbs. Weight kg 40. Available also with shades with graphics "Adventures in the sea" e "Flowers&Raven".

vedi anche/see also ESMERALDA applique-wall lamp, ESMERALDA lampada da tavolo-table lamp, ESMERALDA piantana-floor lamp

● click here

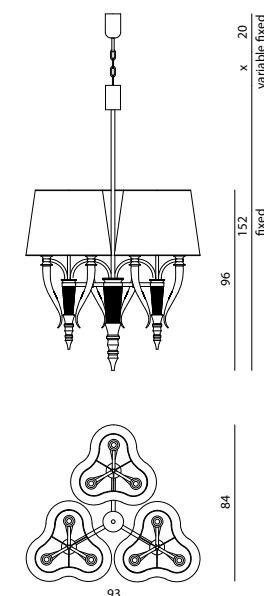

GALAHAD

LAMPADARIO - CHANDELIER

Philippe Montels

Lampadario a sospensione in scaglie di alluminio naturale o champagne montate su struttura in acciaio galvanizzato. Sorgenti luminose 6W LED cad.

Ceiling lamp in aluminium armour-plate or champagne plate put on a galvanized steel frame. Light 6W LED each.

● click here

Peso - Weight kg 31
Power Max W.1440
Bulbs n.36
Type: G9-40W or 6W LED

Peso - Weight kg 60
Power Max W.2080
Bulbs n.52
Type: G9-40W or 6W LED

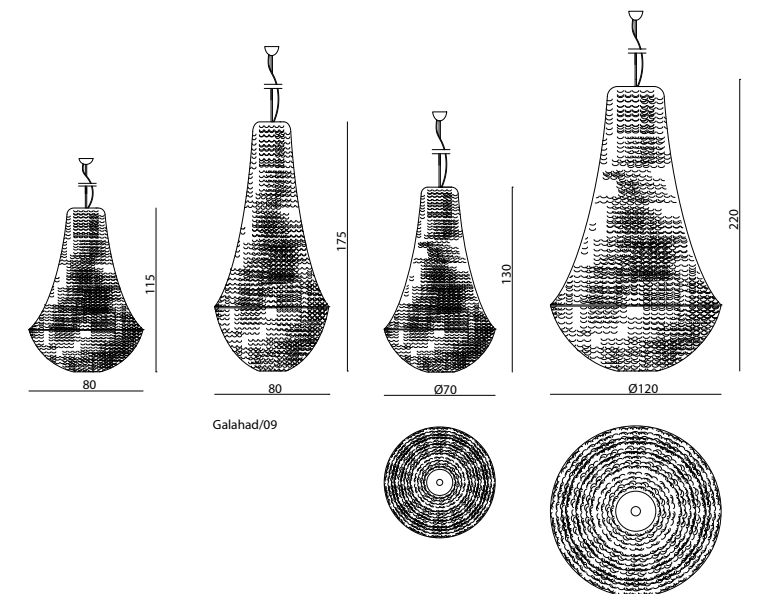

Peso - Weight kg 23
Power Max W.1120
Bulbs n.28
Type: n.2 G9-40W or 6W LED

Peso - Weight kg 23
Power Max W.800
Bulbs n.20
Type: G9-40W or 6W LED



GALAHAD/P

PLAFONIERA - CEILING LAMP

Philippe Montels

Sospensione in scaglie di alluminio naturale o champagne montate su struttura in acciaio galvanizzato. In opzione pendenti in cristallo Swarovski. Sorgenti luminose 6W LED cad.

Ceiling lamp in aluminium plate with natural or champagne finishing put on a galvanized steel frame. Swarovski crystals pendants as optional. Light 6W LED each.

● [click here](#)

| | | |
|---|---|---|
| Peso - Weight kg 15 Power Max Watts 400 Bulbs n.10 Type: G9-40W or 6W LED | Peso - Weight kg 21 Power Max Watts 560 Bulbs n.14 Type: G9-40W or 6W LED | Peso - Weight kg 27 Power Max Watts 640 Bulbs n.16 Type: G9-40W or 6W LED |
|---|---|---|

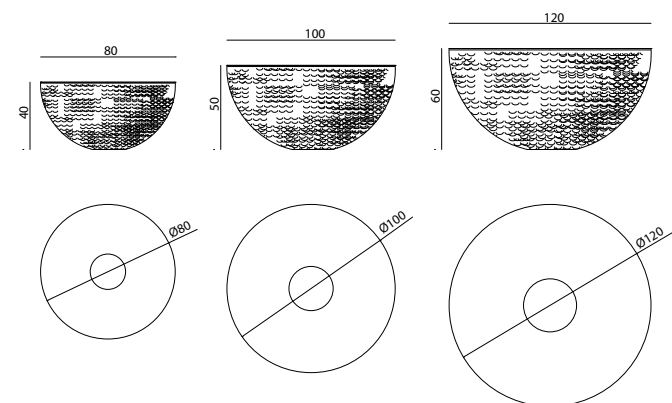

HOLLY

PLAFONIERA - CEILING LAMP

Samuele Mazza

Struttura circolare in acciaio cromato, adornata con doppio giro di catene in alluminio cromato e cristalli. Disponibile nelle versioni:
- Holly/22 con catene e cristalli di diametro 22 mm.
- Holly/14 con catene e cristalli di diametro 14 mm.
- Holly Chains, solo con catene.
Disponibile in altezze da 200 cm a 450 cm.
Sorgenti luminose 6W LED cad.

Circular structure in chromed steel, adorned with double row of chains in chromed aluminium and crystals. Available in versions:
- Holly/22 with chains and crystals with a diameter of 22 mm.
- Holly/14 with chains and crystals with a diameter of 14 mm.
- Holly Chains, only with chains.
Available in height from 200 cm up to 450 cm.
Light 6W LED each.

● [click here](#)

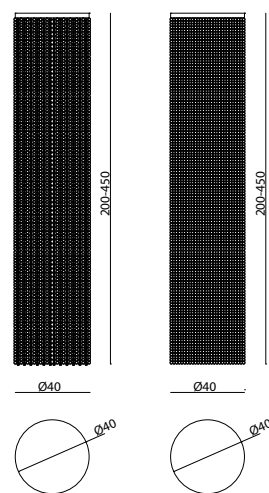

H.200 cm con ottagoni 14/22mm
Peso - Weight kg 18/20
Bulbs n.12
Type: Halogen G9 max 40W
or 6W LED

H.450 cm con ottagoni 14/22mm
Peso - Weight kg 40/46
Bulbs n.15
Type: Halogen G9 max 40W
or 6W LED

H.200 cm con solo catena
Peso - Weight kg 13
Bulbs n.12
Type: Halogen G9 max 40W
or 6W LED

H.450 cm con solo catena
Peso - Weight kg 30
Bulbs n.15
Type: Halogen G9 max 40W
or 6W LED



SYLAR

LAMPADARIO - CHANDELIER

La Conca

Lampadario ovale in maglia di cristallo tessuto a mano formato da cinque drappi cascanti, incrociati a diverse altezze. Struttura portante in acciaio inox satinato, impianto a 20 luci G9, 40W - 6W LED cad. Disponibile con impianto audio Bluetooth a 2 vie High-fidelity, potenza max 800W. Peso 90 Kg.

Oval chandelier made of five crystal mesh hanging drapes, crossed at different heights. Support structure in brushed stainless steel, 20 G9 light system, 40W - 6W LED each. Available with High-fidelity 2-way Bluetooth audio system, max power 800W. Weight 90 Kg.

● [click here](#)

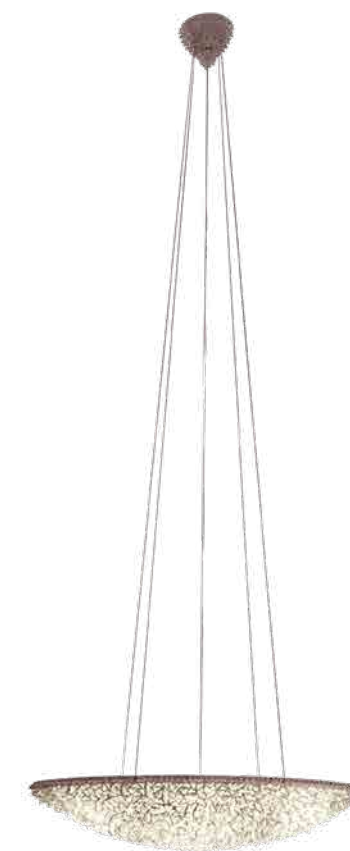
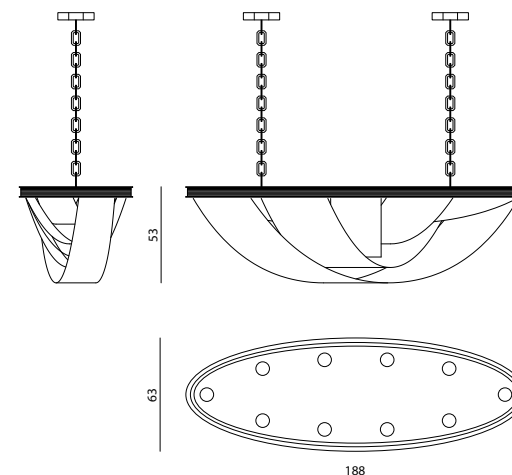

THOTH

LAMPADARIO - CHANDELIER

Giuseppe Campanella - Samuele Mazza

Lampadario a scudo ellittico ottenuto per giustapposizione di schegge in vetro ghiaccio su calotta preformata a mano in stagno. Provvisto di tiranti con possibilità di regolazione in altezza e rosone a soffitto a schegge in vetro ghiaccio. Versione 90x33 cm: impianto elettrico predisposto per l'utilizzo di n. 4 lampade a basso consumo E27 60W - 8W LED cad. Peso 22 Kg. Versione 68x28 cm: impianto elettrico predisposto per l'utilizzo di n. 2 lampade a basso consumo E27 60W - 8W LED cad. Peso 13 kg.

Oval shield-shaped chandelier made up of overlapped ice glass flakes fixed to a handcrafted tin cap. The unit is provided with ropes that allow the height adjustment. Ceiling cup with ice glass flakes. Version 90x33 cm: electrical system predisposed for the use of n. 4 low consumption light bulbs E27 60W - 8W LED each. Weight 22 kg. Version 68x28 cm: electrical system predisposed for the use of n. 2 low consumption light bulbs E27 60W - 8W LED each. Weight 13 kg.

vedi anche/see also THOTH applique-wall lamp

● [click here](#)

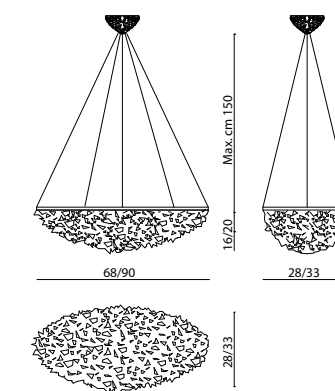



WOTAN

PLAFONIERA - CEILING LAMP

Samuele Mazza

Montatura esagonale in acciaio nikel-satinato. Strass in cristalli di Boemia, motivo octagon, e pendenti in cristallo, motivo foglia. 6 lampade G9 40W - 6W LED cad. Disponibile in due versioni: altezza cm 130 (peso 25 kg); altezza cm 70 (peso 12 kg).

Hexagonal frame in steel satin-nickel. Hanging crystal chains are in hexagonal shape Bohemia crystal and pendants are in leaf shaped crystal. 6 lamps G9 40W - 6W LED each. Available in two versions: height 130 cm (weight 25 kg); height 70 cm (weight 12 kg).

[● click here](#)

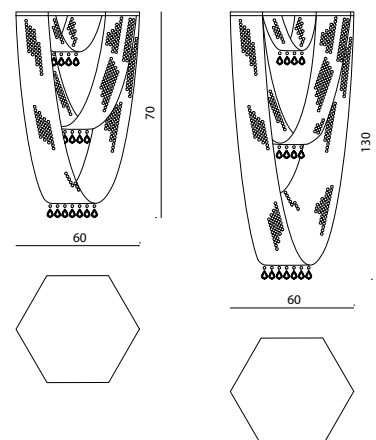

- click on the icons -



AKIRA p.416



ALPHA p.417



ARACEA p.417



BRANDO p.418



CALLIA p.418



ETHAN p.419



FLORO p.419



MILANO p.420



MOON-EYE p.420



PARADE p.421



POLARIS p.421



REBEL p.422



ROCK p.422



SPUTNIK p.423



THAÏS p.423



WAVE p.424



ZYKLUS p.424

- click on the icons -

ICONICI - *ICONIC*



AMANDA p.426



AMARILLI p.426



BRUNILDE p.427



ESMERALDA p.427



THOTH p.428



ZANTAS p.428



AKIRA

APPLIQUE - WALL LAMP

Alessandro La Spada

Applique a 4 luci o a una luce, struttura tubolare o a stelo, in metallo lucidato o satinato. Portalampane in ottone tornito e luci G9 40W - 6W LED cad. con diffusore in vetro satinato. Paralumi concavi in tessuto con diffusore interno moiré avorio. Le parti in metallo sono disponibili nella selezione finiture metalliche. Peso 5 Kg (4 luci); 3 Kg (1 luce).

4 lights or single light wall lamp with polished or satin metal structure. Lampholders in turned brass and lights G9 40W - 6W LED each, with frosted glass diffuser. Concave lampshades in fabric with internal ivory moiré diffuser. Metal parts available in the metal finishing selection. Weight 5 Kg (4 lights) Kg 3 (1 light).

vedi anche/see also AKIRA lampadario-chandelier, AKIRA lampada da tavolo-table lamp, AKIRA ABAT-JOUR lampada da tavolo-table lamp, AKIRA lampada da terra, floor lamp

● click here

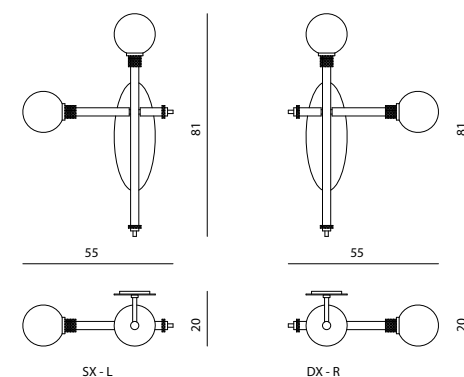
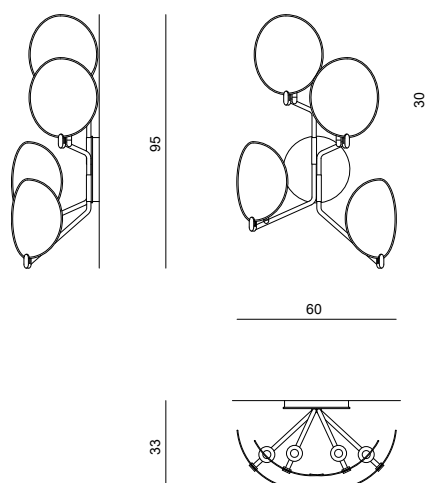
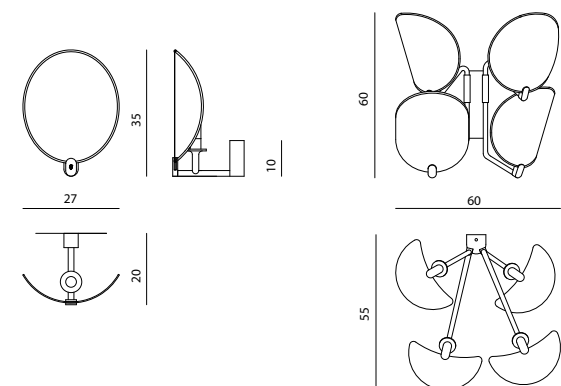

ALPHA

APPLIQUE - WALL LAMP

Giuseppe Viganò

Applique in ottone e vetro soffiato. Struttura in tubi di ottone con finitura bicolore e bracciali di ottone massiccio scolpito. Diffusori sferici in vetro soffiato con finitura opalina satinata. Le parti in metallo sono disponibili nella selezione finiture metalliche. Sorgente luminosa a 2 luci G9 40W - 6W LED cad. Peso 5 kg.

Wall lamp in brass and blown glass. Structure in tubular brass with bicolour finish and rings in sculpted solid brass. Spherical diffuser in blown glass with satin opaline finish. Metal components can be finished with any lacquer of the metal lacquer finish selection. 2 lights G9 40W - 6W LED each light source. 5 kg weight.

vedi anche/see also ALPHA lampadario-chandelier, ALPHA lampada da tavolo-table lamp, ALPHA piantana-floor lamp

● click here

ARACEA

APPLIQUE - WALL LAMP

Gupica

Struttura in ottone e alluminio satinato con luci "a foglia" in acciaio inox. Sorgente luminosa lineare a LED. Tutte le "foglie" sono regolabili sia nell'inclinazione che nella rotazione. Disponibile nella selezione finiture metalliche, la faccia superiore della foglia in finitura lucida e quella inferiore satinata. Disponibile in versione a due foglie (potenza assorbita 7W LED, peso 4 kg), a tre foglie (potenza 11W LED, peso 5 kg) ed a due foglie predisposta per fissaggio sulla testata del letto (potenza 7W LED, peso 3 kg). Questo modello monta sorgenti luminose a LED a lunga durata integrate nella struttura della lampada, non sostituibili dall'utente.

Structure in brass and satin aluminium with four "leaf-shaped" lights in stainless steel. Linear LED light source. The rotation and the inclination of all the leaves can be adjusted. Base in satin metal. Available in any lacquer included in the metal finish selection, the upper face of the "leaf" in polished finish and the lower face in satin finish. Available in two leaves or three leaves version (absorption power 7W LED, weight 4 kg; power 11W LED, weight 5 kg) and two leaves version predisposed to fix to headboard bed (power 7W LED, weight 3 kg). This model is equipped with long-life LED light sources integrated into the lamp structure, which cannot be replaced by the user.

vedi anche/see also ARACEA lampadario a sospensione-ceiling lamp, ARACEA lampada da terra-floor lamp, ARACEA lampada cielo-terra-floor to ceiling lamp, ARACEA lampada da tavolo-table lamp

● click here

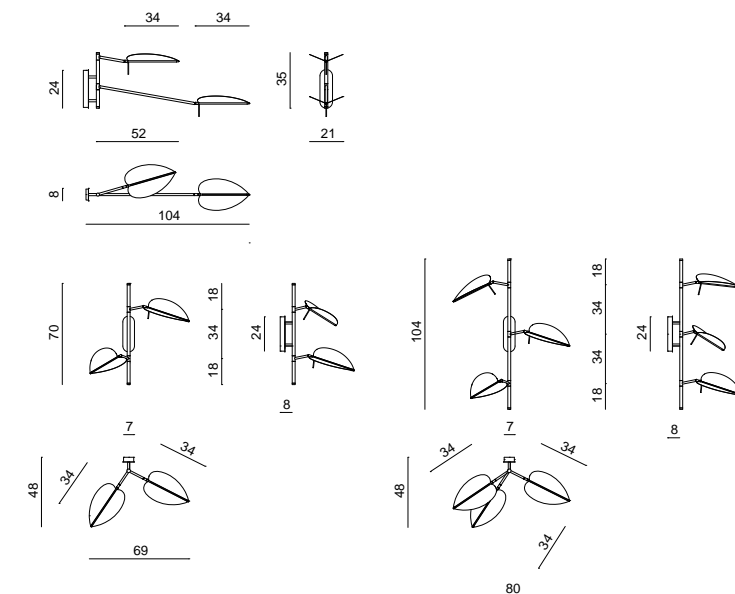



BRANDO

APPLIQUE - WALL LAMP

Samuele Mazza

Applique in metallo e onice. Struttura portante in acciaio e ottone con finitura satinata cromo o oro. Paralumi in Onice Avorio sp. 8 mm sospesi a formare una figura sfaccettata e illuminati da un impianto di 5 luci G9 40W - 6W LED cad. Assorbimento max 160W, peso 15 kg.

Wall lamp in metal and onyx. Main structure in steel and brass with satinized chromed or gold finishings. Lampshades in Ivory Onyx, 8 mm in width, creating a multi-faceted effect. Lighting system for 4 light bulbs G9 40W - 6W LED each, max 160W in total, weight 15 kg

vedi anche/see also BRANDO lampadario-chandelier

● click here

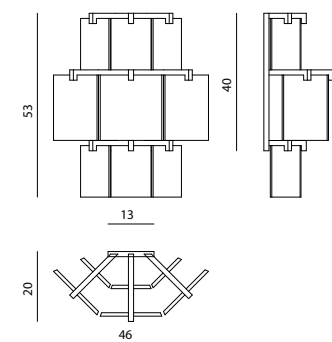

CALLIA

APPLIQUE - WALL LAMP

Alessandro La Spada

Lampada in acciaio inox con paralume a forma di foglia, ottenuta da una sottile lamina deformata a freddo, con superficie lucida a effetto "metallo liquido", internamente satinata con superficie anti-abbagliamento. Stelo centrale con sorgente luminosa a LED DS da 4,5W. Elemento decorativo in marmo. Le parti metalliche sono disponibili nella selezione finiture metalliche. Questo modello monta sorgenti luminose a LED DS a lunga durata integrate nella struttura della lampada, non sostituibili dall'utente. Peso: 5 Kg (versione mini), 8 kg (verione Big).

Disponibile anche in versione Dehors.

Lamp in stainless steel with leaf-shaped diffuser, obtained from a thin cold-finished layer, with shiny surface with "liquid metal" effect, internally satin with anti-glare surface. Central stem with LED DS light with 4,5W power. Decorative element in marble. Metal parts can be lacquered in any colour included in the metal finish selection. This model is equipped with long-life LED DS light sources integrated into the lamp structure, which can not be replaced by the user. Weight: 5 kg (mini version) - 8 kg (big version).

Available also in Dehors version.

vedi anche/see also CALLIA lampada da tavolo-table lamp, CALLIA piantana-floor lamp, CALLIA dehors

● click here

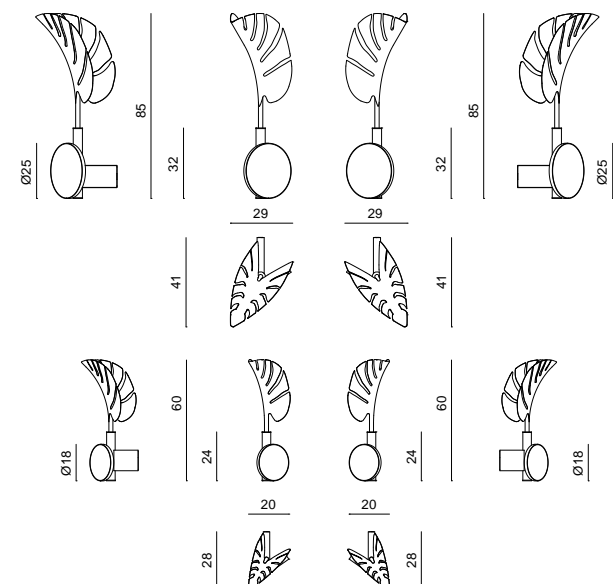

ETHAN

APPLIQUE - WALL LAMP

Alessandro La Spada

Applique a colonna in vetro. Struttura portante in acciaio e ottone satinato, con spigoli sfaccettati e superfici laterali in vetro rigato. Corpi illuminanti a LED a luce calda integrati nel telaio. Piastra di attacco a parete in acciaio rivestito in specchio, assorbimento 20W, peso 10 kg. Questo modello monta sorgenti luminose a LED a lunga durata integrate nella struttura della lampada, non sostituibili dall'utente. Le parti in metallo sono disponibili nella selezione finiture metalliche satinate.

Column-shaped wall lamp. Main structure in steel and satinized brass, with multi-faceted edges and sides in grooved glass. Warm light LED bars integrated in the structure. Plate for wall-fixing, coated in mirror, max 20W in total, weight 10 kg. This model is equipped with long-life LED light sources integrated into the lamp structure, which cannot be replaced by the user. Metal parts can be lacquered in any colour included in the satinized metal finish selection.

vedi anche/see also ETHAN lampadario-chandelier, ETHAN lampada da tavolo-table lamp

● click here

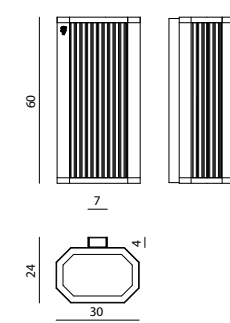

FLORO

APPLIQUE - WALL LAMP

Alessandro La Spada

Struttura in ottone e acciaio, un elemento luminoso in vetro soffiato con dispersione di foglia d'oro incastonato in un bracciale metallico. Impianto a 2 luci LED E14 max 8W ognuna, peso 6 Kg. Le parti metalliche sono disponibili nella selezione finiture metalliche lucide.

Structure in brass and steel, one light element in blown glass containing gold leaf particles, encased in a metal bracelet. Lighting system consists of 2 LED bulbs E14 max 8W each, weight 6 Kg. Metal parts can be lacquered in any colour of the polish metal finish selection.

vedi anche/see also FLORO lampadario-ceiling lamp, FLORO lampada da terra-floor lamp, FLORO lampada da tavolo-table lamp

● click here

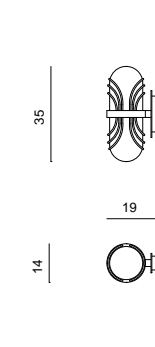



MILANO

APPLIQUE - WALL LAMP

Armando Bruno - Alberto Torres

Applique in marmo e acciaio. Struttura superiore in metallo con lavorazione "rigata" in bassorilievo e corpo centrale in marmo massello. Diffusore a prisma in policarbonato massello lucido con finitura interna opalina satinata. Sorgente luminosa a COB-LED 8W max. Le parti in metallo sono disponibili nella selezione finiture metalliche, il corpo centrale in marmo è disponibile monocromatico o a due colori alternati. Peso 6 kg.

Wall lamp in marble and steel. Upper part in metal with low-relief 'stripes' decoration and central body in solid marble. Prismatic diffuser in shiny solid polycarbonate with satin opaline internal finish. COB-LED light 8W max. Metal parts available in any lacquer of the metal lacquer finish selection. Central body in one or two marbles. Weight 6 kg.

vedi anche/see also MILANO lampadario-chandelier, MILANO lampada da tavolo-table lamp, MILANO piantana-floor lamp

● click here

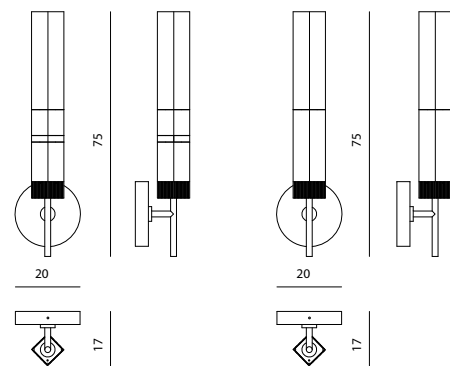

VERSIONE A DUE MARMI
DOUBLE MARBLE VERSION

VERSIONE A SINGOLO MARMO
SINGLE MARBLE VERSION



MOON-EYE

APPLIQUE - WALL LAMP

Mauro Lipparini

Applique a una luce, struttura portante in legno massello di noce canaletto scolpito con sezione a tre lobi, con diffusore costituito da un piatto a sezione ridotta in onice o quarzite fissato alla struttura tramite staffe in metallo lucido. Portalampada in acciaio lucido con sorgente GU10 fissata al corpo in legno, staffa di attacco a parete in metallo lucido. Le parti in metallo sono disponibili nella selezione finiture metalliche. Sorgente luminosa GU10 10W LED. Peso 5 kg.

Wall lamp with one light, main structure in Canaletto walnut solid wood, with carved three-lobes section. Plate diffuser in onyx or quartzite slab connected to the structure using shiny metal brackets. Lamp holder in shiny steel with GU10 light fixed to the wooden structure. Wall mounting bracket in shiny metal. Metal parts can be finished with any of the metal lacquer finish selection. GU10 10W LED light source. Weight 5 kg.

vedi anche/see also MOON-EYE lampada da tavolo-table lamp, MOON-EYE piantana-floor lamp

● click here

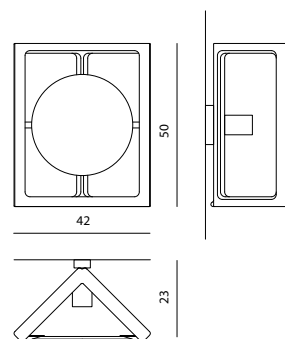

PARADE

APPLIQUE - WALL LAMP

Studio Pepe

Applique tubolare con diffusori in vetrofusione. Barra portante in acciaio con doppia sorgente luminosa a LED, superiore e inferiore. Tre o cinque diffusori irregolari in vetrofusione da 6 mm parzialmente sovrapposti realizzati manualmente e trattati a forno, attraversati dal taglio dalla luce. Staffa di fissaggio a parete completa di alimentazione. Assorbimento 30W, peso 5 kg (versione a 3 diffusori) o 7 kg (versione a 5 diffusori). Parti metalliche disponibili nella selezione finiture metalliche. Questo modello monta sorgenti luminose a LED a lunga durata integrate nella struttura della lampada, non sostituibili dall'utente.

Tubular wall light with fused glass diffusers. Steel support bar with double LED light source (top and bottom). Three or five irregular, partially overlapping, 6 mm glassfusion diffusers made by hand and oven-treated, through which the light is cut. Wall mounting bracket complete with power supply. Power consumption 30W, weight 5 kg (3-diffuser version) or 7 kg (5-diffuser version). Metal parts available in the metal finish selection. This model mounts long-life LED light sources integrated in the lamp structure, not replaceable by the user.

vedi anche/see also PARADE lampadario-chandelier

● click here

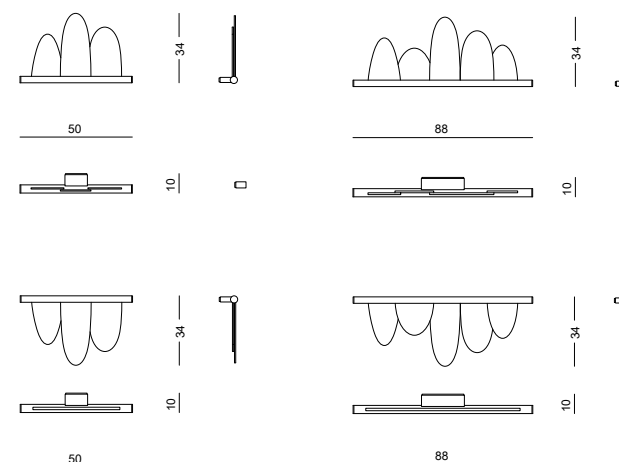

POLARIS

APPLIQUE - WALL LAMP

Alessandro La Spada

Lampada da parete composta da un elemento curvo in alluminio lucidato nella parte esterna e satinato nella parte interna, con diffusore in marmo retroilluminato con lavorazione del bordo a "spacco vivo". Illuminazione a LED COB. Le parti metalliche sono disponibili nella selezione finiture metalliche. Peso versione small 3 kg - potenza complessiva 3W. Peso versione big 7 kg.

Wall lamp consisting of a curved element in polished aluminium on the outside and satin-finished aluminium on the inside, with diffuser in backlit vein-cut marble with raw cut edges. Lighting system: LED COB. Metal parts available in any lacquer of the metal finish selection. Weight 3 kg in the small version, total watt 3W. Big version, weight 7 kg.

vedi anche/see also POLARIS lampadario-chandelier, POLARIS lampada da tavolo-table lamp, POLARIS dehors

● click here

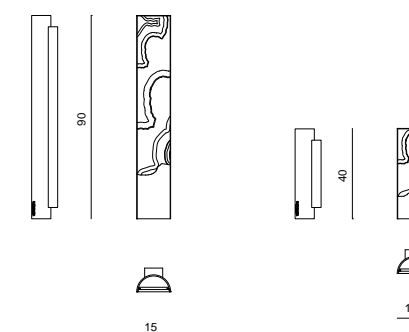



REBEL

APPLIQUE - WALL LAMP
Alessandro La Spada

Applique a 3 luci in metallo cromato con diffusori in onice e acciaio. Struttura portante in tubo metallico con elettrificazione a bassa tensione e alimentatore posizionato nella staffa di attacco a parete. Diffusori in acciaio a forma conica contenenti un impianto a luce LED e paralume in onice retroilluminato realizzato da lastra a spessore ribassato. I diffusori sono collegati allo stelo centrale tramite bracci tubolari. Le parti in metallo sono disponibili nella selezione finiture metalliche. Sorgente luminosa a LED lunga durata non sostituibile dall'utente, max 42W LED. Peso 20 kg.

Wall lamp with 3 lights in chromed metal with diffusers in onyx and steel. Main structure in tubular metal, low voltage lighting, power supply positioned in the wall mounting bracket. Conical-shaped diffusers with LED backlight lampshade in onyx, shaped from a milled stone slab. Diffusers positioned on tubular arms, structurally connected to central stem. Metal parts can be finished with any lacquer of the metal lacquer finish selection. LED light source sources, which can not be replaced by the user. 42W max. Weight 20 kg.

vedi anche/see also REBEL specchio-mirror, REBEL lampadario-chandelier, REBEL lampada da tavolo-table lamp

● click here

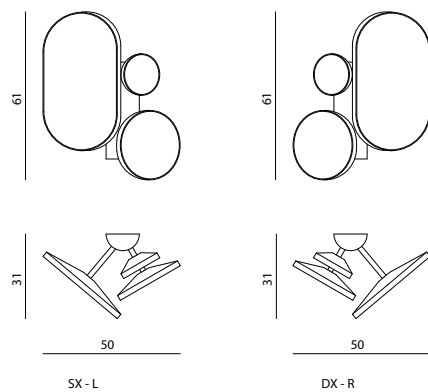

ROCK

APPLIQUE - WALL LAMP
Alessandro La Spada

Applique disponibile con una o due luci. Corpi illuminanti a LED contenuti in barre di acciaio che sostengono il diffusore in onice di forma irregolare. Le parti in metallo sono disponibili nella selezione finiture metalliche. Potenza e peso: 1 luce: 11W, peso 10 Kg, 2 luci: 22W, peso 15 kg. Questo modello monta sorgenti luminose a LED a lunga durata integrate nella struttura della lampada, non sostituibili dall'utente.

Wall lamp available with one or two lights. LED lighting bodies framed by steel bars sustaining the onyx diffuser with irregular shape. Metal parts can be finished with every lacquer included in the metal finish selection. Watt and weight: 1 light - 11W, weight 10 kg, 2 lights - 22W, weight 15 kg. This model comes with long-lasting LED lights integrated in the very lamp structure; henceforth, they cannot be replaced by the end user.

vedi anche/see also ROCK lampadario-chandelier, ROCK lampada da tavolo-table lamp

● click here

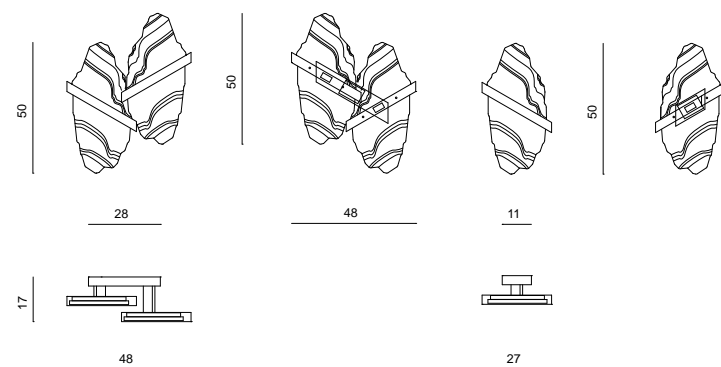

SPUTNIK

APPLIQUE - WALL LAMP
Draga & Aurel

Elemento in acciaio tubolare contenente sorgenti LED e paralumi diffusori romboidali deformati a freddo in finitura lucida. Le parti in metallo sono disponibili nella selezione finiture metalliche lucide. 6 luci: assorbimento max. 25W, peso 3 Kg; 4 luci: assorbimento max. 20W, peso 2 Kg. Ingresso cablaggio nel supporto superiore. Questo modello monta sorgenti luminose a LED a lunga durata integrate nella struttura della lampada, non sostituibili dall'utente.

Element in tubular steel containing LED lights and cold cured rhombus-shaped lampshades with polish finish. Metal parts available in any finish included in the metal finish selection. 6 lights: power 25W, weight 3 kg; 4 lights: power 20W, weight 2 kg. Wiring entry in the upper support. This model is equipped with long-life LED light sources integrated into the lamp structure, which can not be replaced by the user.

vedi anche/see also SPUTNIK sospensione-suspension lamp, SPUTNIK-OXY sospensione-suspension lamp

● click here

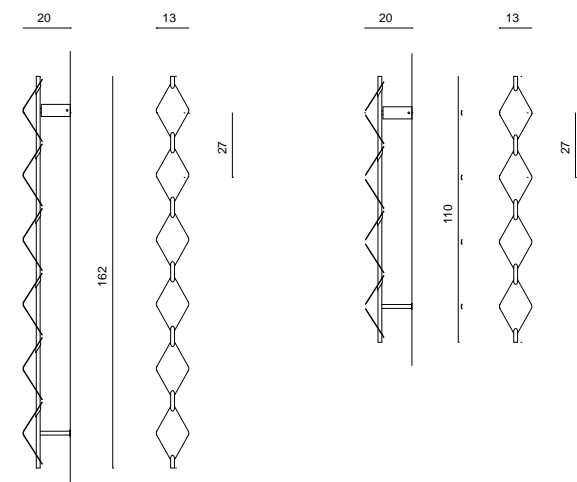

THAIS

APPLIQUE - WALL LAMP
Marta Naddeo

Applique con luci in vetro soffiato e metallo. Elementi soffiati in vetro trasparente con texture "corteccia" a base quadrata con lato di 14 cm. I diffusori si appoggiano su elementi metallici a piramide in acciaio inox contenenti una sorgente LED COB CRI90 da 7W. Attacco a parete scatola con alimentatore incluso. Peso 6 kg.

Wall light with blown glass and metal lights. Blown clear glass elements with 'bark' texture with a 14 cm square base. The diffusers rest on stainless steel metal pyramid elements containing a 7W COB CRI90 LED source. Boxed wall fixing with power supply included. Weight 6 kg.

vedi anche/see also THAIS lampada da terra-floor lamp

● click here

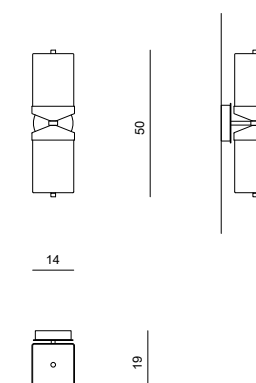



WAVE

APPLIQUE - WALL LAMP

Alessandro La Spada

Applique in marmo massello scolpito da blocco di grosso spessore, conformato a prisma con pianta a "V". Stelo diffusore in acciaio inox con sorgente a LED a luce diffusa da 10W e due faretti GU10 max 50W. Struttura portante in tubo metallico con elettrificazione a bassa tensione e alimentatore posizionato nella staffa di attacco a parete. Il massello di marmo e disponibile nelle varianti Invisible grey, Elegant Dune e Emperador Light. Peso 18 kg.

Wall lamp in solid marble, carved from thick block, with prismatic shape and V section. Diffuser in stainless steel with LED diffuse light (10W) and two GU10 spot-lights (max 50W). Main structure in metal tube, low voltage lighting system, power supply positioned in the wall mounting bracket. Weight 18 kg.

vedi anche/see also WAVE lampada da tavolo-table lamp

[● click here](#)

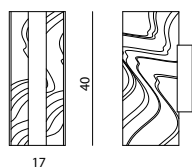

ZYKLUS

APPLIQUE - WALL LAMP

Marta Naddeo

Applique in vetro soffiato e metallo. Piastra di attacco a parete in acciaio inox con tre punti luce in vetro soffiato trasparente ad alto spessore, di diverse dimensioni a texture "balloton", "rigato" e "ritorto". I vetri, a sfera schiacciata, ospitano una sorgente a LED COB CRI90 da 5W con diffusore interno e copertura in metallo con stelo decorativo. Le parti in metallo sono disponibili nella selezione finiture metalliche. Peso: 10 kg.

Wall light in blown glass and metal. Wall-mounting plate in stainless steel with three points of light in high-thickness transparent blown glass, in different sizes with 'balloton', 'striped' and 'twisted' textures. The flattened spherical glass houses a 5W COB CRI90 LED source with an internal diffuser and metal cover with decorative stem. The metal parts are available in the metal finish selection. Weight: 10 kg.

[● click here](#)

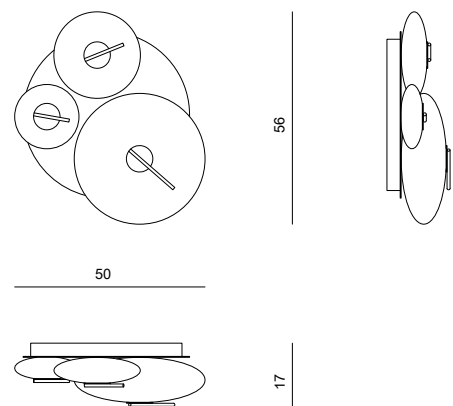



AMANDA

APPLIQUE - WALL LAMP
Philippe Montels

Paralume semi-cilindrico realizzato con scaglie di alluminio naturale o champagne, montato su piastra in acciaio cromato, per il fissaggio alla parete. Opzionale: possibilità di applicazione pendagli in cristallo Swarovski. 2 lampade G9 40W - 6W LED cad. Peso 5 kg.

Half-cylindric lampshade with natural or champagne aluminium plates, mounted on two plates in chromed steel to be fixed to the wall. Optional: application of pendants in Swarovski crystal. 2 bulbs G9 40W - 6W LED each. Weight 5 kg.

● click here

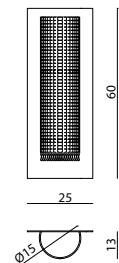

AMARILLI

APPLIQUE - WALL LAMP
Alessandro La Spada

Placca a parete in acciaio inox lucido lacca oro. Stelo con tornerie alluminio cromo o lacca oro. Tubolari in ottone trafilato "torchon" anticato. Decorì taglio laser in ottone anticato. 2 lampade E27 60W - 8W LED cad. Paralume a lobi in seta nera e interno in materiale riflettente oro. Peso 6 kg. Disponibile anche con paralumi con grafica "Adventures in the sea" e "Flowers&Raven".

Wall plate in gold lacquered polished stainless steel. Stem with turnings in chromed or gold lacquer aluminium. Tubulars in drawn antique brass "torchon". Laser-cut antique brass decorations. 2 lamps E27 60W - 8W LED each. Lampshade with lobes in black silk and internal in gold reflective material. Weight 6 kg. Available with lampshades with "Adventures in the sea" and "Flowers & Raven" coverings.

vedi anche/see also AMARILLI lampadario-chandelier, AMARILLI lampada da tavolo-table lamp, AMARILLI piantana-floor lamp

● click here

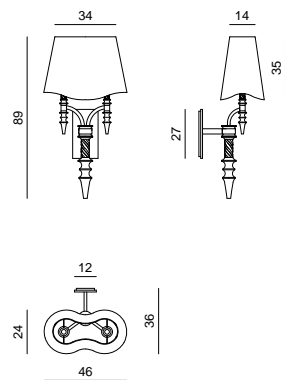

BRUNILDE, BRUNILDE ALL, BRUNILDE UNICORNO

APPLIQUE - WALL LAMP

Alessandro La Spada - Samuele Mazza

Coni ricurvi e lancia centrale in ottone cromato; particolari in alluminio tornito; piastra di fissaggio in acciaio. Paralume ovale tronco conico in seta crema o in opzione, in seta nera e interno in materiale riflettente oro; per la versione "all", in scaglie di alluminio naturale con opzione possibilità di applicazione di pendenti in cristallo Swarovski. Applique H.159 cm predisposta per l'utilizzo di 2 lampadine E27 10W LED cad. Peso 11 kg. Applique H.104 cm predisposta per l'utilizzo di 2 lampadine E27 10W LED cad. Peso 7 kg. Applique unicorno H.65 cm predisposta per l'utilizzo di 1 lampadina E14 8W LED. Peso 5 kg. Disponibili in versione CONTRACT con struttura e particolari in metallo cromato.

Curved cones and central lance in chromed brass; details in lathed aluminium; plate for fixing to wall in steel. Oval lampshade of conical truncated cone in cream silk, or option, black silk and gold inner reflective material, for "all" version, shape in natural aluminium plates with possibility of application of pendants in Swarovski crystals. Wall light H.159 cm prepared for use with 2 light bulbs E27 10W LED each - Weight 11 kg. Wall light H.104 cm prepared for use with 2 light bulbs E27 10W LED each - Weight 7 kg. Wall light H.65 cm prepared for use with 1 light bulb E14 8W LED - Weight 5 kg. Available also CONTRACT versions with structure and particulars in chromed metal.

vedi anche/see also BRUNILDE lampadario-chandelier

● click here

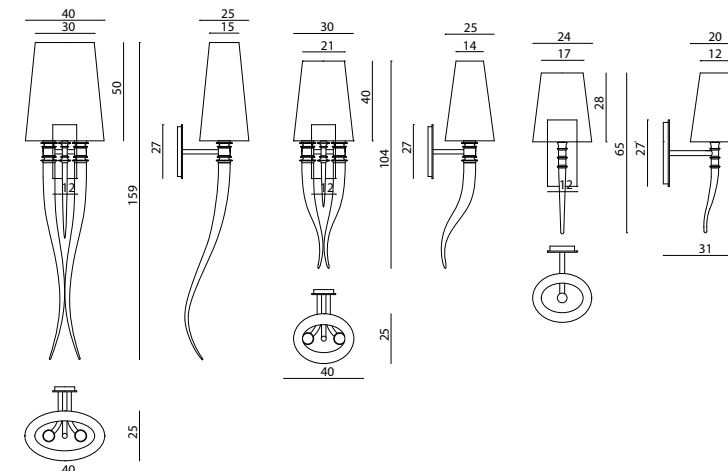

ESMERALDA

APPLIQUE - WALL LAMP
Alessandro La Spada

Struttura in ottone finitura lucida color oro, corna tronco coniche in ottone laccato, elemento in cristallo a piombo soffiato molato, con lavorazione bugnata, finitura acidata. Paralume in tessuto nero con l'interno oro lucido, per tutte le versioni le lampadine sono E27 60W - 8W LED cad; per la versione applique ci sono 2 lampadine. Disponibile anche in versione angolare. Disponibile anche con paralumi con grafica "Adventures in the sea" e "Flowers&Raven". Peso 6 kg.

Structure in brass in gold shiny finishing. Half-truncated horns in lacquered brass. Lead crystal element, blown and grinded, with studded shape and frosted finishing. Lampshade in black fabric with gold internal decoration. For all the versions, the bulbs needed are E27 60W - 8W LED each: wall lamp - 2 bulbs. Available also in corner fixing version. Weight 6 kg. Available also with shades with graphics "Adventures in the sea" e "Flowers&Raven".

vedi anche/see also ESMERALDA lampada da tavolo-table lamp, ESMERALDA piantana-floor lamp

● click here

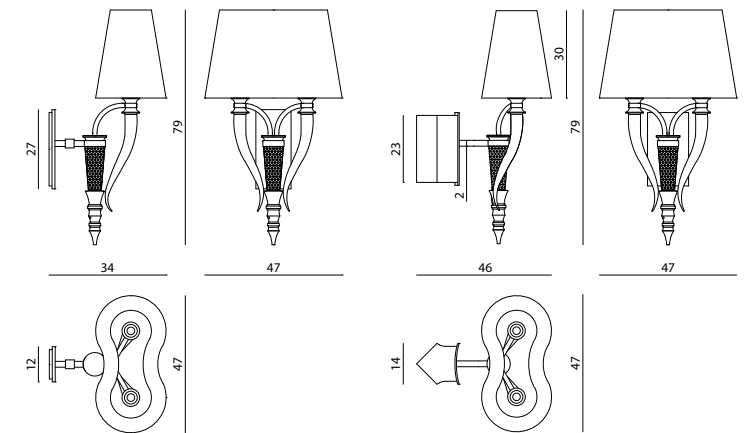

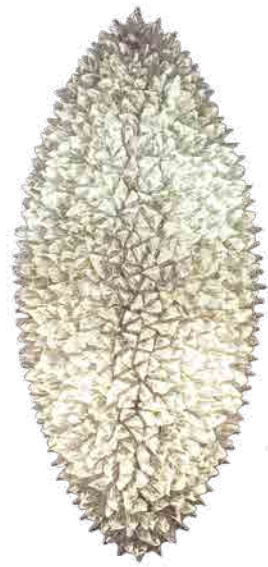

THOTH

APPLIQUE - WALL LAMP

Giuseppe Campanella - Samuele Mazza

Applique a scudo ellittico ottenuto per giustapposizione di schegge in vetro ghiaccio su calotta preformata a mano in stagno. Impianto elettrico predisposto per l'utilizzo di n. 2 lampade a basso consumo E27 60W - 8W LED cad. Peso 13 kg.

Oval shield-shaped wall light made up of overlapped ice glass flakes fixed to a handcrafted tin cap. Electrical system predisposed for the use of no. 2 low consumption light bulbs E27 60W - 8W LED each. Weight 13 kg.

vedi anche/see also THOTH lampadario-chandelier

● [click here](#)

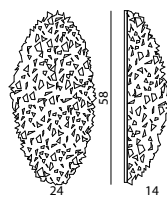

ZANTAS

APPLIQUE - WALL LAMP

Samuele Mazza

Piastra scatolare a parete in acciaio cromato. Stelo "taglio diamante" in fusione d'alluminio cromato lucido oppure oro. Anello torchon in ottone cromato oppure oro. Paralume in seta tronco cono oppure in scaglie d'alluminio naturale o champagne. Impianto elettrico predisposto per l'utilizzo di n.1 lampadina E14 60W - 8W LED cad. Peso 8 kg (paralume in seta); 12 kg (paralume in alluminio).

Box plate in chromed steel to be fixed to the wall. "Diamond cut" stand in shiny chromed or golden aluminium fusion. Twisted ring in chromed or golden brass. Truncated lampshade in silk. Electrical system predisposed for the use of no. 1 bulb E14 60W - 8W LED each. Weight: 8 kg (silk lampshade); 12 kg (aluminium lampshade).

● [click here](#)

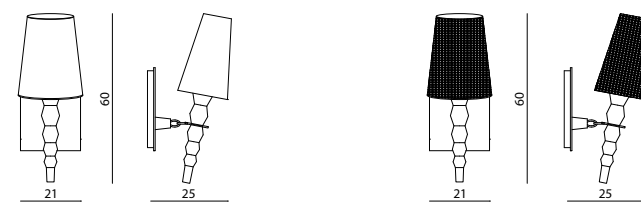

- click on the icons -

- click on the icons -



AKIRA p.432



AKIRA ABAT-JOUR p.432



ALPHA p.433



ARACEA p.433



ASTRA p.434



BARNABY STRAIGHT p.434



BARNABY ROUND p.435



BEATRICE p.435



CALLIA p.436



ELDER p.436



ETHAN p.437



FLORO p.437



JASPER p.438



LYDIA p.438



MILANO p.439



MOON-EYE p.439



OMEGA p.440



POLARISp.440



POLARIS ABAT-JOUR p.441



REBEL p.441



ROCK p.442



ROMA p.442



SOLVEIG p.443



STILO p.443



THAÏS p.444



WAVE p.444

ICONICI - *ICONIC*



AMARILLI p.446



EGG p.446



ESMERALDA p.447



AKIRA

LAMPADA DA TAVOLO - TABLE LAMP

Alessandro La Spada

Lampada da tavolo a una luce con base di appoggio in metallo lucidato o satinato, con paralume verticale concavo "a ventaglio" in tessuto stampato floreale oppure a campionario, con diffusore interno in moiré avorio. Paralume posteriore anti abbagliante in acciaio inox microforato con trama grafica floreale. Portalampana in ottone tornito e luce G9 40W - 6W LED cad con diffusore in vetro. Le parti in metallo sono disponibili nella selezione finiture metalliche.

One light table lamp with polished or satin metal base, with concave fan shaped vertical lampshade in printed floral fabric (available also according to sample fabric), with internal ivory moiré diffuser. Anti-glare rear lampshade in micro-perforated stainless steel with floral graphic texture. Lampholder in turned brass and G9 40W - 6W LED bulb with glass diffuser. Metal parts available in the metal finishing selection.

vedi anche/see also AKIRA lampadario-chandelier, AKIRA applique-wall lamp, AKIRA lampada da terra-floor lamp

● click here

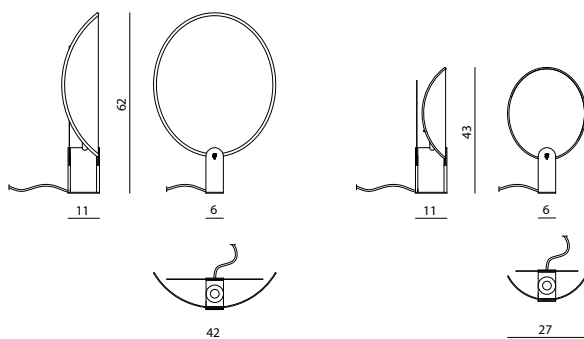

AKIRA ABAT-JOUR

LAMPADA DA TAVOLO - TABLE LAMP

Alessandro La Spada

Lampada da tavolo a una luce con base di appoggio in metallo lucidato o satinato, con paralume verticale concavo "a ventaglio" in tessuto o pelle (disponibile con ricamo 'Ca' Foscarì o 'Ultrasound'). Portalampana in ottone tornito e luce G9 40W - 6W LED cad con diffusore in vetro. Le parti in metallo sono disponibili nella selezione finiture metalliche.

One light table lamp with polished or satin metal base, with concave fan shaped vertical lampshade in fabric or leather (available also with 'Ca' Foscarì or 'Ultrasound' embroidery). Lampholder in turned brass and G9 40W - 6W LED bulb with glass diffuser. Metal parts available in the metal finishing selection.

● click here

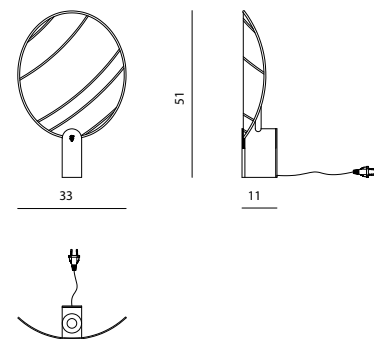

ALPHA

LAMPADA DA TAVOLO - TABLE LAMP

Giuseppe Viganò

Lampada da tavolo in ottone e vetro soffiato. Struttura in tubi di ottone con finitura bicolore e bracciali di ottone massiccio scolpito. Diffusori sferici in vetro soffiato con finitura opalina satinata. Disponibile in versione piccola (1 luce G9 40W - 6W LED, peso 2 kg.), media (2 luci G9 40W - 6W LED, peso 4 kg.) e grande (2 luci G9 40W - 6W LED, peso 5 kg.). Le parti in metallo sono disponibili nella selezione finiture metalliche.

Table lamp in brass and blown glass. Structure in tubular brass with bi-colour finish and rings in sculpted solid brass. Spherical diffuser in blown glass with satin opaline finish. Small (1 light G9 40W - 6W LED light source, 2 kg weight), medium (2 lights G9 40W - 6W LED light source, 4 kg weight) and big version (2 lights G9 40W - 6W LED, 5 kg weight) available. Metal components can be finished with any lacquer of the metal lacquer finish selection.

vedi anche/see also ALPHA lampadario-chandelier, ALPHA applique-wall lamp, ALPHA piantana-floor lamp

● click here

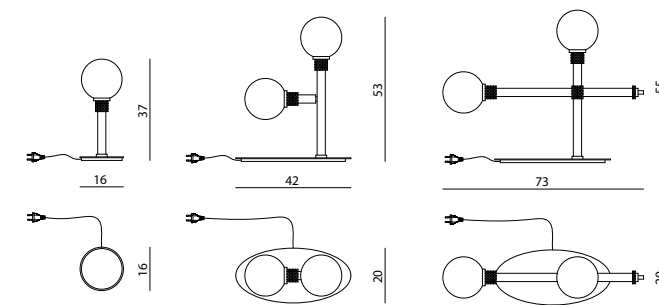

ARACEA

LAMPADA DA TAVOLO - TABLE LAMP

Gupica

Struttura in ottone e alluminio satinato con luci "a foglia" in acciaio inox. Sorgente luminosa lineare a LED, con interruttore touch dimmerabile sulla base. Le "foglie" sono regolabili sia nell'inclinazione che nella rotazione. Disponibile nella selezione finiture metalliche, la faccia superiore della foglia in finitura lucida e quella inferiore satinata. Disponibile in versione a foglia singola o doppia. Potenza assorbita 8W, peso 7 kg (versione a due foglie), 4,5W, peso 5 kg (versione a foglia singola), 4,5W, peso 1 kg (versione a foglia singola da appoggio). Questo modello monta sorgenti luminose a LED a lunga durata integrate nella struttura della lampada, non sostituibili dall'utente.

Structure in brass and satin aluminium with four "leaf-shaped" lights in stainless steel. Linear LED light source with dimmable touch switch on the base. The rotation and the inclination of all the leaves can be adjusted. Available in any lacquer included in the metal finish selection, the upper face of the "leaf" in polished finish and the lower face in satin finish. Available in single leaf or double leaf version. Absorption power 6W, weight 7 kg (double leaf version), 3W, weight 5 kg (single leaf version), 3W, weight 1 kg (single leaf countertop version). This model is equipped with long-life LED light sources integrated into the lamp structure, which cannot be replaced by the user.

vedi anche/see also ARACEA lampadario a sospensione-ceiling lamp, ARACEA lampada da terra-floor lamp, ARACEA lampada cielo-terra-floor to ceiling lamp, ARACEA applique-wall lamp

● click here

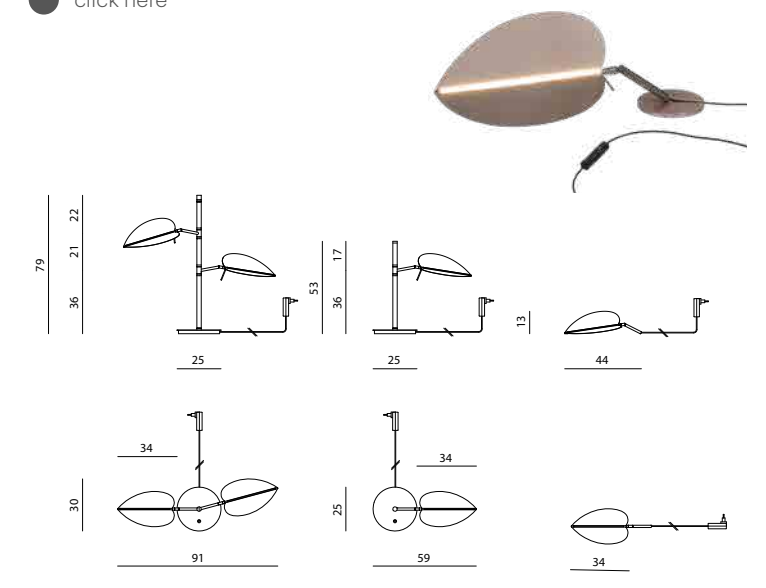



ASTRA

LAMPADA DA TAVOLO - TABLE LAMP

Marco Piva

Lampada da tavolo in metallo cromato lucido e vetro soffiato, con paralume conico intagliato in bassorilievo a righe orizzontali, con veletta in vetro soffiato parzialmente satinato. Stelo conico con terminale in vetro soffiato. L'impianto si compone di 3 sorgenti luminose LED E14 da 6W a luce calda. Questo modello monta sorgenti luminose a LED a lunga durata integrate nella struttura della lampada, non sostituibili dall'utente.

Table lamp in polished chromed metal and blown glass, with conical lampshade carved in low-relief horizontal stripes, with partially satinized-blown glass. Conical stem with blown glass terminal. The system consists of three 6W E14 LED light sources with warm light. This model is equipped with long-life LED light sources integrated into the lamp structure, which can not be replaced by the user.

● [click here](#)

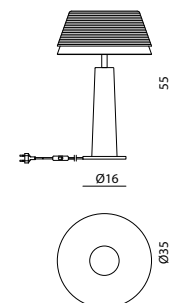

BARNABY STRAIGHT

LAMPADA DA TAVOLO - TABLE LAMP

Alessandro La Spada

Lampada da lettura ricaricabile. Base in marmo lucidato e metallo, stelo in ottone e diffusore lineare regolabile. Nella base sono contenuti una batteria e un sistema di ricarica wireless abbinabile al divano Babylon Rack (ricarica sullo schienale) o a dispositivi di ricarica standard Qi. È possibile ricaricare la batteria anche tramite cavo USB-C (cavo incluso, caricatore non fornito). Le parti metalliche sono disponibili nella selezione finiture metalliche satiniate.

Rechargeable table lamp. Base in polished marble and metal, stem in brass and adjustable linear diffuser. The base contains a battery and a wireless charging technology matching Babylon Rack charger (positioned on the backrest) or any wireless charging system with Qi technology. It is also possible to charge the battery using a USB-C cable (cable provided, charger not included). Metal parts available with any lacquer of the satin metal finish selection.

● [click here](#)

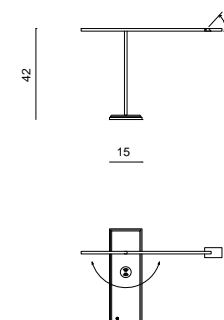

BARNABY ROUND

LAMPADA DA TAVOLO - TABLE LAMP

Alessandro La Spada

Lampada da lettura ricaricabile. Base in marmo lucidato e metallo, stelo in ottone e diffusore a disco. Nella base sono contenuti una batteria e un sistema di ricarica wireless abbinabile al divano Babylon Rack (ricarica sullo schienale) o a dispositivi di ricarica standard Qi. È possibile ricaricare la batteria anche tramite cavo USB-C (cavo incluso, caricatore non fornito). Le parti metalliche sono disponibili nella selezione finiture metalliche satiniate.

Rechargeable table lamp. Base in polished marble and metal, stem in brass and circular diffuser. The base contains a battery and a wireless charging technology matching Babylon Rack charger (positioned on the backrest) or any wireless charging system with Qi technology. It is also possible to charge the battery using a USB-C cable (cable provided, charger not included). Metal parts available with any lacquer of the satin metal finish selection.

● [click here](#)

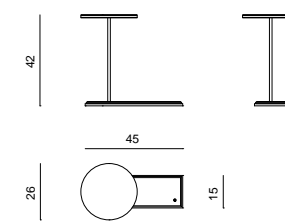

BEATRICE

LAMPADA DA TAVOLO - TABLE LAMP

Alessandro La Spada

Lampada da tavolo in acciaio e marmo. Struttura a ponte in acciaio con elementi portanti cilindrici concavi e convessi, con diffusore lineare in marmo lavorato a mano. Secondo diffusore opalino sotto il corpo lampada per l'illuminazione del piano di lavoro. Due sorgenti a LED lineari dimmerabili. Assorbimento 20W, peso 7 kg. Le parti metalliche sono disponibili nella selezione finiture metalliche. Questo modello monta sorgenti luminose a LED a lunga durata integrate nella struttura della lampada, non sostituibili dall'utente.

Table lamp in steel and marble. Bridge structure in steel with concave and convex cylindrical elements, with linear handmade marble diffuser. Second opaline diffuser under the body lamp for the lighting of the work surface. Two dimmable linear LED sources. 20W absorption, weight 7 kg. The metal parts are available in the metal finishes selection. This model is provided with longlasting LED light sources integrated into the lamp structure, not replaceable by the end user.

● [click here](#)

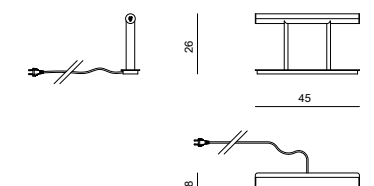



CALLIA

LAMPADA DA TAVOLO - TABLE LAMP

Alessandro La Spada

Lampada in acciaio inox con paralume a forma di foglia, ottenuta da una sottile lamina deformata a freddo, con superficie lucida a effetto "metallo liquido", internamente satinata con superficie anti-abbagliamento. Stelo centrale con sorgente luminosa a LED DS da 6W. Base in metallo con zavorra ed elemento decorativo in marmo. Le parti metalliche sono disponibili nella selezione finiture metalliche. Questo modello monta sorgenti luminose a LED a lunga durata integrate nella struttura della lampada, non sostituibili dall'utente.

Lamp in stainless steel with leaf-shaped diffuser, obtained from a thin cold-finished layer, with shiny surface with "liquid metal" effect, internally satin with anti-glare surface. Central stem with LED DS light with 6W power. Base in metal with ballast and decorative element in marble. Metal parts can be lacquered in any colour included in the metal finish selection. This model is equipped with long-life LED light sources integrated into the lamp structure, which can not be replaced by the user.

vedi anche/see also CALLIA applique-wall lamp, CALLIA piantana-floor lamp, CALLIA dehors

● click here

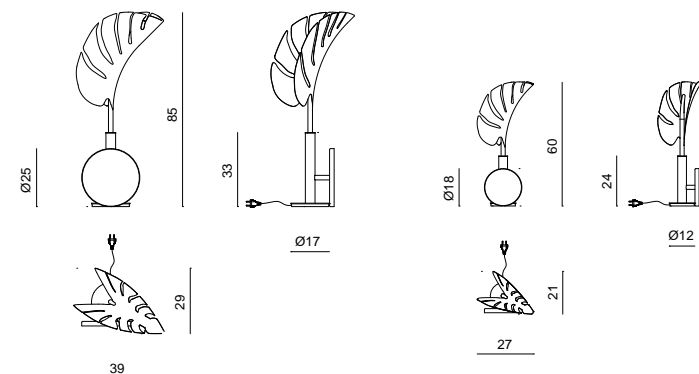

ELDER

LAMPADA DA TAVOLO - TABLE LAMP

Fabio Bonfà

Struttura in acciaio inox satinato con inserto in legno nero lucido e base in marmo, portalampane E27 60W - 8W LED cad, paralume in tessuto intrecciato o raso nero con interno bianco. Le parti in acciaio sono disponibili nella selezione finiture metalliche satiniate.

Structure in satinized stainless steel with insert in shiny black lacquered wood and base in marble, bulb E27 60W - 8W LED each, lampshade in woven fabric or black satin with white interior. Metal parts available in the satinized metal finishing selection.

vedi anche/see also ELDER piantana-floor lamp

● click here

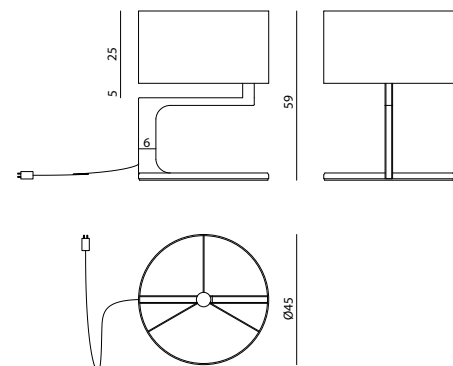

ETHAN

LAMPADA DA TAVOLO - TABLE LAMP

Alessandro La Spada

Lampada da tavolo in vetro. Struttura portante in acciaio e ottone satinato, con spigoli sfaccettati e superfici laterali in vetro rigato. Corpi illuminanti a LED a luce calda integrati nel telaio. Base d'appoggio in acciaio inox lucidato, assorbimento 20W, peso 12 kg. Questo modello monta sorgenti luminose a LED a lunga durata integrate nella struttura della lampada, non sostituibili dall'utente. Le parti in metallo sono disponibili nella selezione finiture metalliche satiniate.

Small table lamp in glass. Main structure in steel and satinized brass, with multi-faceted edges and sides in grooved glass. Warmlight LED bars integrated in the structure. Base in polished stainless steel, max 20W in total, weight 12 kg. This model is equipped with long-life LED light sources integrated into the lamp structure, which cannot be replaced by the user. Metal parts can be lacquered in any colour included in the satinized metal finish selection.

vedi anche/see also ETHAN lampadario-chandelier, ETHAN applique-wall lamp

● click here

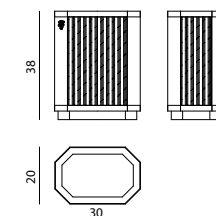

FLORO

LAMPADA DA TAVOLO - TABLE LAMP

Alessandro La Spada

Struttura in ottone e acciaio, due elementi luminosi in vetro soffiato con dispersione di foglia d'oro incastonati in un bracciale metallico. Stelo e base in acciaio. Impianto a 4 luci LED E14 max 8W ognuna. Le parti metalliche sono disponibili nella selezione finiture metalliche lucide.

Structure in brass and steel, two light elements in blown glass containing gold leaf particles, encased in a metal bracelet. Stem and base in steel. Lighting system consists of 4 LED bulbs E14 max 8W each. Metal parts can be lacquered in any colour of the polish metal finish selection.

vedi anche/see also FLORO lampadario-ceiling lamp, FLORO lampada da terra-floor lamp, FLORO applique-wall lamp

● click here

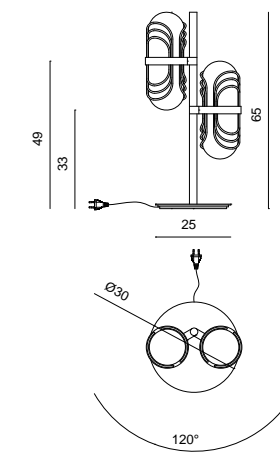



JASPER

LAMPADA DA TAVOLO - TABLE LAMP

Fabio Bonfà

Lampada da tavolo in ottone massiccio e marmo. Proiettore lineare in ottone contenente una sorgente LED dimmerabile a luce calda da 6W, stelo composto da un doppio tubo di ottone e un elemento conico in marmo massello, base in acciaio satinato. Le parti metalliche sono disponibili nella selezione finiture metalliche satinato. Questo modello monta sorgenti luminose a LED a lunga durata integrate nella struttura della lampada, non sostituibili dall'utente.

Disponibile versione JASPER RADICA, con elemento conico rivestito in radica con finitura lucida 100 gloss.

Table lamp in solid brass and marble. Linear brass projector containing a 6W dimmable LED warm light source, stem consisting of a double brass tube and a conical solid marble element, base in satinized steel. Metal parts available in the satinized metal finishing selection. This model is equipped with long-life LED light sources integrated into the lamp structure, which can not be replaced by the user.

JASPER RADICA version available with conical element upholstered in polished burr walnut with 100 gloss finish. Available in marble: Calacatta Gold, White Carrara, Black Marquina.

● click here



VERSIONE RADICA/ RADICA VERSION

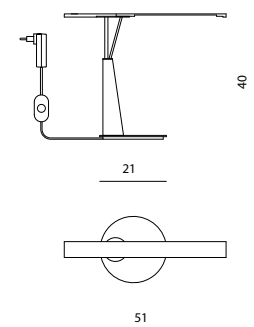

LYDIA

LAMPADA DA TAVOLO - TABLE LAMP

Giuseppe Viganò

Stelo a cuneo in massello di marmo sagomato e lucidato, base circolare in metallo e marmo, paralume a cupola in acciaio satinato con diffusore opalino, illuminazione a LED 28W, 3000°K. Le parti in metallo sono disponibili nella selezione finiture metalliche. Questo modello monta sorgenti luminose a LED a lunga durata integrate nella struttura della lampada, non sostituibili dall'utente.

Wedge-shaped stem in shaped and polished solid marble, circular base in metal and marble, dome-shaped shade in satin-finished steel with opaline diffuser, 28W LED lighting, 3000°K. The metal parts are available in the metal finish selection. This model has long-life LED light sources integrated into the structure of the lamp, which cannot be replaced by the user.

● click here

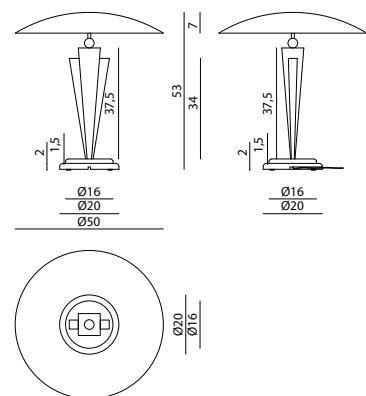

MILANO

LAMPADA DA TAVOLO - TABLE LAMP

Armando Bruno - Alberto Torres

Lampada da tavolo in marmo e acciaio. Struttura superiore in metallo con lavorazione "rigata" in bassorilievo e corpo centrale in marmo massello. Diffusore a prisma in policarbonato massello lucido con finitura interna opalina satinata. Sorgente luminosa a COB-LED 8W max. Le parti in metallo sono disponibili nella selezione finiture metalliche, il corpo centrale in marmo è disponibile monocromatico o a due colori alternati. Peso 12 kg.

Table lamp in marble and steel. Upper part in metal with low-relief 'stripes' decoration and central body in solid marble. Prismatic diffuser in shiny solid polycarbonate with satin opaline internal finish. COB-LED light 8W max. Metal parts available in any lacquer of the metal lacquer finish selection. Central body in one or two marbles. Weight 12 kg.

vedi anche/see also MILANO lampadario-chandelier, MILANO applique-wall lamp, MILANO piantana-floor lamp

● click here

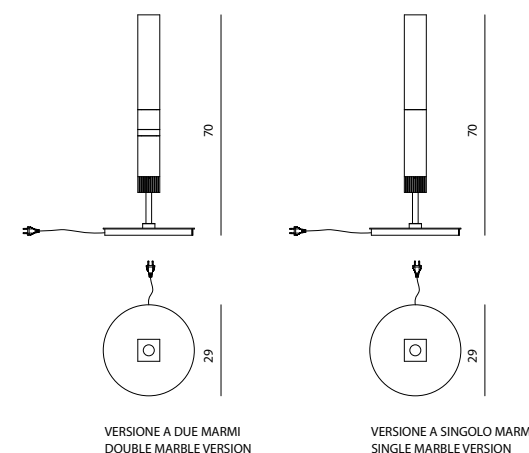

MOON-EYE

LAMPADA DA TAVOLO - TABLE LAMP

Mauro Lipparini

Versione mini: lampada da tavolo a una luce, struttura portante in legno massello di noce canaletto scolpito con sezione a tre lobi, con diffusore costituito da un piatto a sezione ridotta in onice o quarzite fissato alla struttura tramite staffe in metallo lucido. Portalampana in acciaio lucido con sorgente a LED fissata al corpo in legno, cavo di alimentazione a vista in treccia di tessuto grigio, base di appoggio in acciaio lucido. Le parti in metallo sono disponibili nella selezione finiture metalliche. Sorgente luminosa a LED 2,5W 3000°K.

Versione big: lampada da tavolo a una luce, struttura portante in legno massello di noce canaletto scolpito con sezione a tre lobi, con diffusore costituito da un piatto a sezione ridotta in onice o quarzite fissato alla struttura tramite staffe in metallo lucido. Portalampana in acciaio lucido con sorgente GU10 fissata al corpo in legno, cavo di alimentazione a vista in treccia di tessuto grigio, base di appoggio in acciaio lucido. Le parti in metallo sono disponibili nella selezione finiture metalliche. Sorgente luminosa GU10 max 10W.

Version Big: table lamp with one light, main structure in Canaletto walnut solid wood, with carved three-lobes section. Plate diffuser in onyx or quartzite slab connected to the structure using shiny metal brackets. Lamp holder in shiny steel with GU10 light fixed to the wooden structure, visible power cord in grey interwoven fabric, base in shiny steel. Metal parts can be finished with any lacquer of the metal lacquer finish selection. GU10 max 10W light source.

Version Mini: table lamp with one light, main structure in Canaletto walnut solid wood, with carved three-lobes section. Plate diffuser in onyx or quartzite slab connected to the structure using shiny metal brackets. Lamp holder in shiny steel with LED light fixed to the wooden structure, visible power cord in grey interwoven fabric, base in shiny steel. Metal parts can be finished with any lacquer of the metal lacquer finish selection. LED 2,5W 3000°K light source.

vedi anche/see also MOON-EYE applique-wall lamp, MOON-EYE piantana-floor lamp

● click here

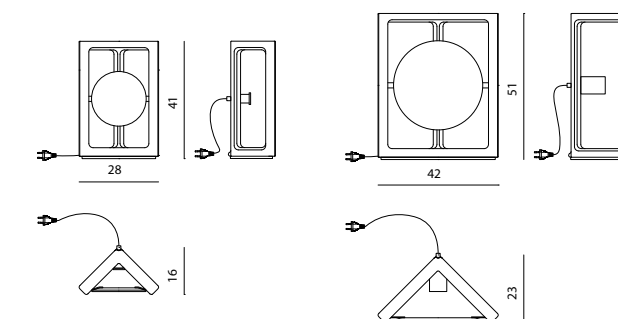



OMEGA

LAMPADA DA TAVOLO - TABLE LAMP

Fabio Bonfà

Lampada da tavolo con diffusore in cristallo molato a mano ad alto spessore, incorniciato da un anello in acciaio contenente una sorgente luminosa a LED da 9W a luce calda dimmerabile. L'anello è sostenuto da una coppia di steli in ottone connessi con una base circolare in marmo. Le parti metalliche sono disponibili nella selezione finiture metalliche. Questo modello monta sorgenti luminose a LED a lunga durata integrate nella struttura della lampada, non sostituibili dall'utente.

Table lamp with diffuser in hand-cut crystal of high thickness, framed by a steel ring containing a 9W LED light source with warm dimmable light. The ring is supported by a pair of brass stems connected to a circular marble base. Metal parts available in the metal finishing selection. This model is equipped with long-life LED light sources integrated into the lamp structure, which can not be replaced by the user.

● click here

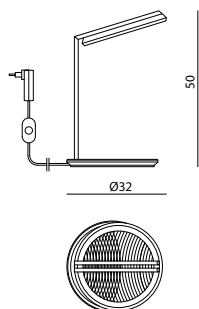

POLARIS

LAMPADA DA TAVOLO - TABLE LAMP

Alessandro La Spada

Lampada da tavolo composta da un elemento curvo in alluminio lucidato nella parte esterna e satinato nella parte interna, con diffusore in marmo retroilluminato con lavorazione del bordo a "spacco vivo". Illuminazione a LED COB. Le parti metalliche sono disponibili nella selezione finiture metalliche. Peso 4 kg - potenza complessiva 3W.

Table lamp consisting of a curved element in polished aluminium on the outside and satin-finished aluminium on the inside, with diffuser in backlit vein-cut marble with raw cut edges. Lighting system: LED COB. Metal parts available in any lacquer of the metal finish selection. Weight 4 kg, total watt 3W.

vedi anche/see also POLARIS lampadario-chandelier, POLARIS applique-wall lamp, POLARIS de hors

● click here

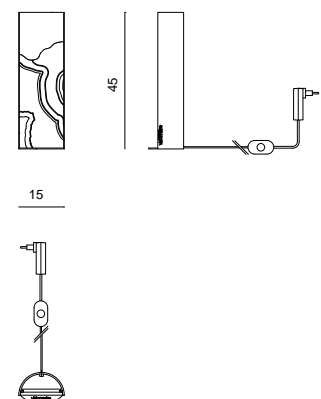

POLARIS ABAT-JOUR

LAMPADA DA TAVOLO - TABLE LAMP

Alessandro La Spada

Lampada da tavolo composta da un elemento curvo in alluminio lucidato nella parte esterna e satinato nella parte interna, con diffusore in marmo retroilluminato con lavorazione del bordo a "spacco vivo". Illuminazione a LED COB. Le parti metalliche sono disponibili nella selezione finiture metalliche. Peso 4 kg, potenza complessiva 3W.

Table lamp consisting of a curved element in polished aluminium on the outside and satin-finished aluminium on the inside, with diffuser in backlit vein-cut marble with raw cut edges. Lighting system: LED COB. Metal parts available in any lacquer of the metal finish selection. Weight 4 kg, total watt 3W.

● click here

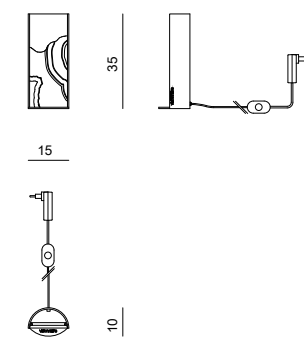

REBEL

LAMPADA DA TAVOLO - TABLE LAMP

Alessandro La Spada

Lampada da tavolo a 3 luci in metallo cromato con diffusori in onice e acciaio. Struttura portante in tubo metallico con elettrificazione a bassa tensione e alimentatore posizionato nella base. Diffusori in acciaio a forma conica contenenti un impianto a luce LED e paralume in onice retroilluminato realizzato da lastra a spessore ribassato. I diffusori sono collegati allo stelo centrale tramite bracci tubolari. Le parti in metallo sono disponibili nella selezione finiture metalliche. Sorgente luminosa a LED, max 20W. Peso 26 kg.

Table lamp with 3 lights in chromed metal with diffusers in onyx and steel. Main structure in tubular metal, low voltage lighting, power supply positioned in the base. Conical-shaped diffusers with LED backlight lampshade in onyx, shaped from a milled stone slab. Diffusers positioned on tubular arms, structurally connected to central stem. Metal parts can be finished with any lacquer of the metal lacquer finish selection. LED light source, 20W max. Weight 26 kg.

vedi anche/see also REBEL specchio-mirror, REBEL lampadario-chandelier, REBEL applique-wall lamp

● click here

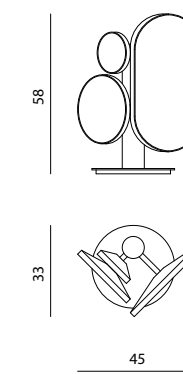



ROCK

LAMPADA DA TAVOLO - TABLE LAMP

Alessandro La Spada

Lampada da tavolo. Corpo illuminante a LED contenuto in una barra di acciaio a sostengono di un diffusore in onice di forma irregolare. Base e supporto in acciaio. Le parti in metallo sono disponibili nella selezione finiture metalliche. Assorbimento: 11W. Questo modello monta sorgenti luminose a LED a lunga durata integrate nella struttura della lampada, non sostituibili dall'utente.

Table lamp. LED lighting body framed by a steel bar sustaining the onyx diffuser with irregular shape. Base and supporting structure in steel. Metal parts can be finished with every lacquer included in the metal finish selection. Absorption: 11W. This model comes with long-lasting LED lights integrated in the very lamp structure; henceforth, they cannot be replaced by the end user.

vedi anche/see also ROCK lampadario-chandelier, ROCK applique-wall lamp

● click here

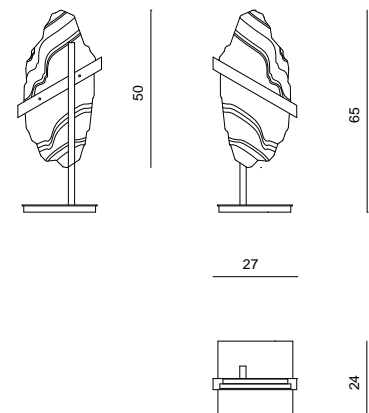

ROMA

LAMPADA DA TAVOLO - TABLE LAMP

Armando Bruno - Alberto Torres

Lampada da tavolo in marmo e acciaio. Struttura in metallo lucido con lavorazione "rigata" in bassorilievo e corpo centrale in lastra di marmo lucidata su tutti i lati e lavorata internamente per il passaggio del cablaggio elettrico. Diffusore sferico in vetro di Murano soffiato con finitura bianco opalino satinato. Le parti decorative in metallo sono disponibili nella selezione finiture metalliche. Sorgente luminosa E14 max 40W oppure a LED 12W, peso 5 kg.

Table lamp in marble and steel. Structure in polished metal with low-relief stripes decoration; central body shaped from slab of polished marble, internally carved to route cables. Spherical diffuser in blown Murano glass with satin white opaline finish. Decorative metal elements can be finished with any lacquer of the metal lacquer finish selection. E14 max 10W or LED 12W light source, 5 kg weight.

vedi anche/see also ROMA lampadario-chandelier

● click here

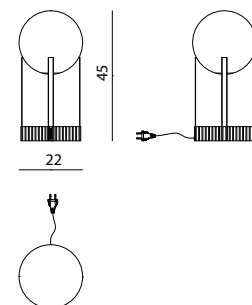

SOLVEIG

LAMPADA DA TAVOLO - TABLE LAMP

Marta Naddeo

Lampada da tavolo in vetro soffiato e metallo. Base in metallo con un punto luce in vetro soffiato trasparente ad alto spessore, a texture "ritorto". Il vetro, a sfera schiacciata, ospita una sorgente a LED COB CRI90 da 7W con diffusore interno e copertura in metallo con stelo decorativo. Le parti in metallo sono disponibili nella selezione finiture metalliche. Peso 4 kg.

Table lamp in blown glass and metal. Metal base with a light point in high-thickness, textured "twisted" transparent blown glass. The glass, with a flattened sphere, houses a 7W COB CRI90 LED source with an internal diffuser and metal cover with a decorative stem. The metal parts are available in the metal finish selection. Weight 4 kg.

● click here

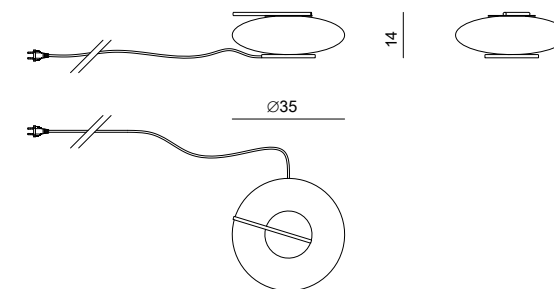

STILO

LAMPADA DA TAVOLO - TABLE LAMP

Alessandro La Spada

Struttura in ottone rigato con tagli obliqui e finitura bicolore lucida o satinata, paralume in tessuto stampato con disegno geometrico o seta nera, portalampade E27 60W - 8W LED cad. Le parti metalliche sono disponibili nella selezione finiture metalliche satinata.

Structure in striped brass with oblique cut and shiny or satinized bicolor finishing, lampshade in printed fabric with geometric pattern or black silk, 1 bulb E27 60W - 8W LED each. Metal parts available in the satinized metal finishing selection.

vedi anche/see also STILO piantana-floor lamp

● click here

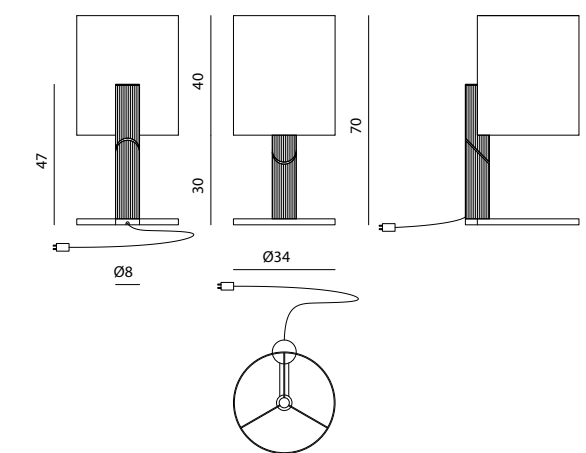



THAIS

LAMPADA DA TAVOLO - TABLE LAMP

Marta Naddeo

Lampada da tavolo in vetro soffiato e metallo. Corpo centrale in vetro soffiato trasparente con texture "corteccia" a base quadrata con lato di 10 cm, abbinato a elementi metallici a piramide in acciaio inox contenente una luce d'ambiente (LED COB da 4W). Diffusore cilindrico in vetro soffiato bianco con sorgente LED COB CRI90 da 7W. Base in acciaio con alimentatore a parete. Disponibile in due misure, peso 8 kg.

Table lamp in blown glass and metal. Central body in transparent blown glass with "bark" texture, square base with 10 cm side, combined with stainless steel metal pyramid elements containing an ambient light (4W COB LED). Cylindrical diffuser in white blown glass with 7W COB CRI90 LED source. Steel base with wall-mounted ballast. Available in two sizes, weight 8 kg.

vedi anche/see also THAIS applique-wall lamp

● [click here](#)

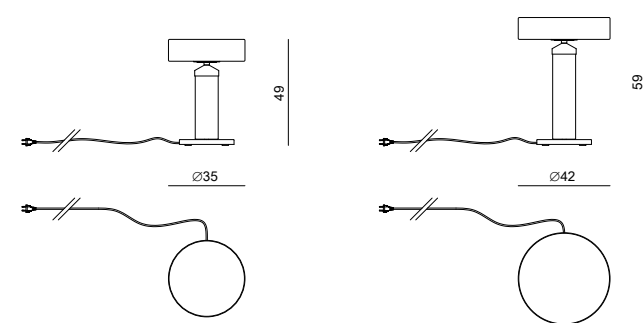

WAVE

LAMPADA DA TAVOLO - TABLE LAMP

Alessandro La Spada

Lampada da tavolo in marmo massello scolpito da blocco di grosso spessore, conformato a prisma con pianta a "V". Stelo diffusore in acciaio inox con sorgente a LED 12W a luce diffusa. Struttura portante in tubo metallico con elettrificazione a bassa tensione e alimentatore posizionato nella base. Il massello di marmo è disponibile nelle varianti Invisible grey, Elegant Dune e Emperador Light. Peso 24 kg.

Table lamp in solid marble, carved from thick block, with prismatic shape and V section. Diffuser in stainless steel with 12W LED diffuse light. Structure in metal tube, low voltage lighting system, power supply positioned in the base. Available options for solid marble: Invisible grey, Elegant dune, Emperador light. Weight 24 kg.

vedi anche/see also WAVE applique-wall lam

● [click here](#)

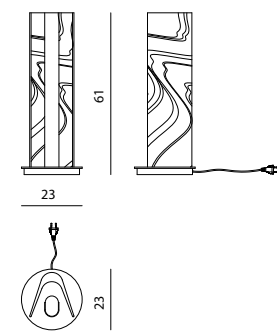



AMARILLI

LAMPADA DA TAVOLO - TABLE LAMP

Alessandro La Spada

Base in acciaio inox lucido lacca oro con zavorra in ferro. Stelo con tornerie alluminio cromo o lacca oro. Tubolari in ottone trafilato "torchon" anticato. Decorazioni taglio laser in ottone anticato. 3 lampade E14 40W - 6W LED cad. Paralume a lobi in seta nera e interno in materiale riflettente oro. Disponibile anche con paralumi con grafica "Adventures in the sea" e "Flowers&Raven".

Base in gold lacquered polished stainless steel with iron ballast. Stem with turnings in chromed or lacquered gold aluminium. Tubulars in drawn antique brass "torchon". Laser-cut antique brass decorations. 3 lamps E14 40W - 6W LED each. Lampshade with lobes in black silk and internal in gold reflective material. Available with lampshades with "Adventures in the sea" and "Flowers & Raven" coverings.

vedi anche/see also AMARILLI lamadario-chandelier, AMARILLI piantana-floor lamp

● click here

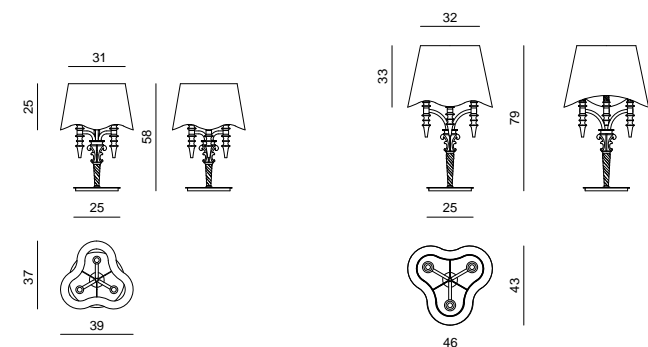

EGG

LAMPADA DA TAVOLO - TABLE LAMP

Philippe Montels - La Conca

Struttura in acciaio inox sagomata a "ova le Visionnaire". Paralume troncocono in seta avorio. Impianto elettrico predisposto per l'utilizzo di n.1 lampada E27 60W - 8W LED per versione Media, E14 40W - 6W LED per versione Mini. Disponibile anche in versione "ALL" con paralume a scaglie di alluminio e pendenti a "square drop" Swarovski. Le parti in metallo sono disponibili nella selezione finiture metalliche.

Structure in stainless steel "oval Visionnaire" shaped. Silk lampshade, truncated cone, in ivory colour. Electrical system predisposed for the use of a E27 light bulb max 60 W for Medium version and E14 max 40 W for Mini version. Also available in "ALL" with shade in aluminium flakes and pendants to "square drop" Swarovski. Metal parts can be lacquered in any colour included in the metal finish selection.

● click here

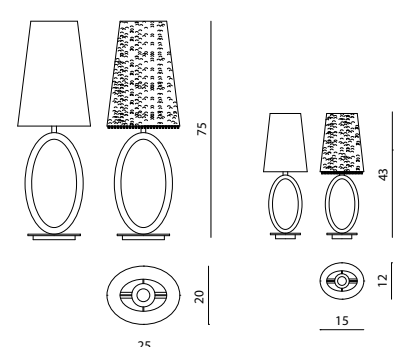

ESMERALDA

LAMPADA DA TAVOLO - TABLE LAMP

Alessandro La Spada

Struttura in ottone finitura lucida color oro, corna tronco coniche in ottone laccato, elemento in cristallo a piombo soffiato molato, con lavorazione bugnata, finitura acidata. Paralume in tessuto nero con l'interno oro lucido, per la versione BIG le lampadine sono 3 E27 per 75W - 10W LED, per la versione lampada da tavolo ci sono 3 lampadine E14 per 60W - 8W LED. Disponibile anche con paralumicon grafica "Adventures in the sea" e "Flowers&Raven".

Structure in brass in gold shiny finishing. Half-truncated horns in lacquered brass. Lead crystal element, blown and grinded, with studded shape and frosted finishing. Lampshade in black fabric with gold internal decoration. For the BIG version, the bulbs needed are 3 E27 max 75W - 10W LED; table lamp - 3 E14 bulbs, max 60W - 8W LED. Available also with shades with graphics "Adventures in the sea" e "Flowers&Raven".

vedi anche/see also ESMERALDA piantana-floor lamp

● click here

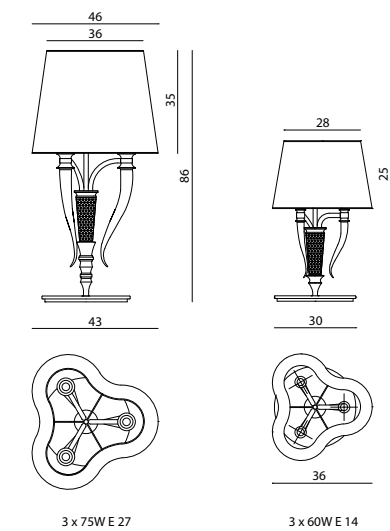

- click on the icons -



AKIRA p.450



ALPHA p.450



APPLE p.451



ARACEA p.451



CALLIA p.452



ELDER p.452



FLORO p.453



FLOYD p.453



MILANO p.454



MOON-EYE p.454



STILO p.455



THAIS p.455

ICONICI - *ICONIC*



AMARILLI p.456



DAGONET p.456



ESMERALDA p.457



AKIRA

PIANTANA - FLOOR LAMP
Alessandro La Spada

Piantana a 6 luci, struttura tubolare a tre piedi in metallo lucidato o satinato. Portalampe in ottone tornito e luci G9 40W oppure 6W LED cadauno con diffusore in vetro satinato. Paralumi concavi in tessuto con diffusore interno moiré avorio. Le parti in metallo sono disponibili nella selezione finiture metalliche.

Piantana a una luce, struttura tubolare con stelo regolabile e basamento a tre piedi, in metallo lucidato o satinato. Portalampe in ottone tornito e luci G9 40W oppure 6W LED con diffusore in vetro satinato. Paralumi concavi in tessuto con diffusore interno moiré avorio. Le parti in metallo sono disponibili nella selezione finiture metalliche.

Floor lamp with 6 lights, tubular structure with three-foot base in polished or satin metal. Lamp holders in lathed brass and G9 40W or 6W LED lights with satin glass diffuser. Concave lampshades in fabric with internal diffuser in ivory "moiré" fabric. The metal parts are available in the metal finishes selection.

Floor lamp with 1 light, tubular structure with adjustable stem and three-foot base in polished or satin metal. Lamp holder in lathed brass and G9 40W or 6W LED lights with satin glass diffuser. Concave lampshades in fabric with internal diffuser in ivory "moiré" fabric. The metal parts are available in the metal finishes selection.

vedi anche/see also AKIRA lampadario-chandelier, AKIRA applique-wall lamp, AKIRA ABAT-JOUR lampada da tavolo-table lamp

● click here

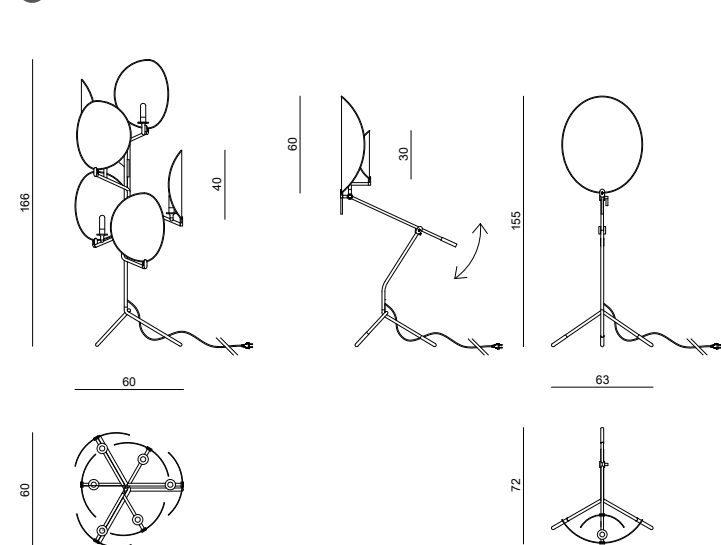

ALPHA

PIANTANA - FLOOR LAMP
Giuseppe Viganò

Piantana in ottone e vetro soffiato. Struttura in tubi di ottone con finitura bicolore e bracciali di ottone massiccio scolpito. Diffusori sferici in vetro soffiato con finitura opalina satinata. Le parti in metallo sono disponibili nella selezione finiture metalliche. Sorgente luminosa a 4 luci G9 40W - 6W LED, peso 15 kg.

Floor lamp in brass and blown glass. Structure in tubular brass with bi-colour finish and rings in sculpted solid brass. Spherical diffuser in blown glass with opaline satin finish. Metal components can be finished with any lacquer of the metal lacquer finish selection. 4 lights G9 40W - 6W LED light source, 15 kg weight.

vedi anche/see also ALPHA lampadario-chandelier, ALPHA applique-wall lamp, ALPHA lampada da tavolo-table lamp

● click here

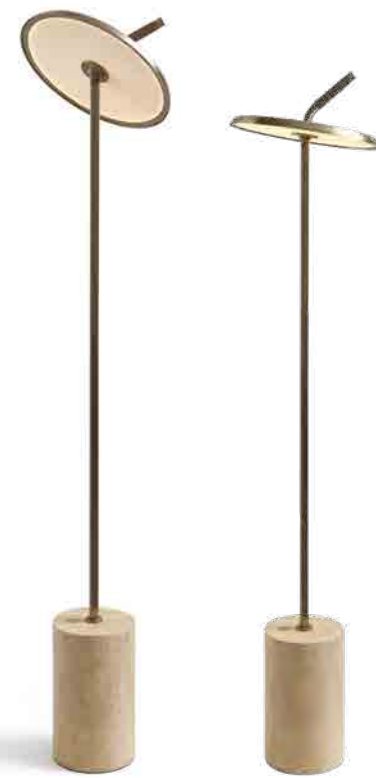
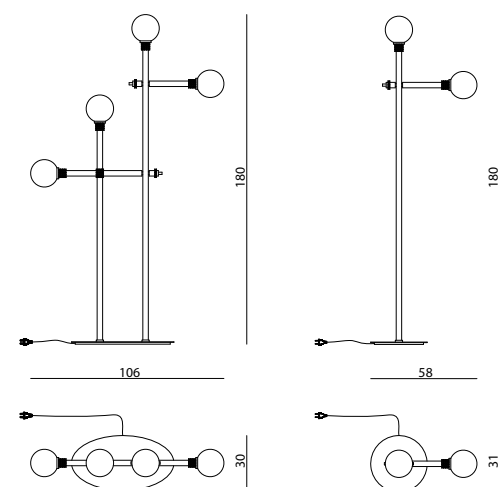

APPLE

LAMPADA DA TERRA - FLOOR LAMP
m2atelier

Lampada da terra da esterno a LED, struttura principale in acciaio inox satinato con base in marmo Travertino, Botticino o Carrara. Il diffusore in metallo e policarbonato è orientabile tramite una maniglia rivestita in cordino di pelle. LED dimmerabile attraverso il comando on/off/dimmer sulla base. Grado di protezione IP44.

Outdoor floor lamp with LED light. Main structure in satin stainless steel with marble base in Travertino, Botticino or Carrara. The orientation of the diffuser in metal and polycarbonate can be adjusted by means of a handle covered in leather rope. LED dimmable light can be controlled by an on/off/dimmer switcher positioned on the base. IP44 protection rating.

● click here

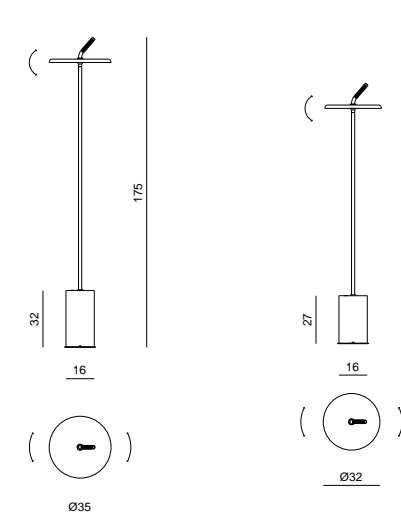

ARACEA

LAMPADA DA TERRA - FLOOR LAMP
Gupica

Struttura in ottone e alluminio satinato con quattro luci "a foglia" in acciaio inox. Sorgente luminosa lineare a LED. Tutte le "foglie" sono regolabili sia nell'inclinazione che nella rotazione. Disponibile nella selezione finiture metalliche, la faccia superiore della foglia in finitura lucida e quella inferiore satinata. Potenza assorbita 15W, peso 20 kg. Questo modello monta sorgenti luminose a LED a lunga durata integrate nella struttura della lampada, non sostituibili dall'utente.

Structure in brass and satin aluminium with four "leaf-shaped" lights in stainless steel. Linear LED light source. The rotation and the inclination of all the leaves can be adjusted. Available in any lacquer included in the metal finish selection, the upper face of the "leaf" in polished finish and the lower face in satin finish. Absorption power 15W, weight 20 kg. This model is equipped with long-life LED light sources integrated into the lamp structure, which cannot be replaced by the user.

vedi anche/see also ARACEA lampadario a sospensione-ceiling lamp, ARACEA lampada cielo-terra-floor to ceiling lamp, ARACEA lampada da tavolo-table lamp, ARACEA applique-wall lamp

● click here

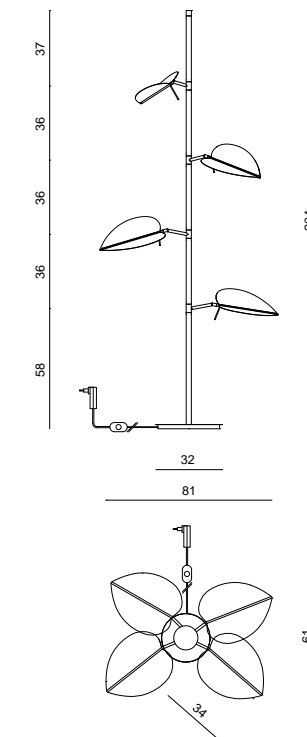



CALLIA

PIANTANA - FLOOR LAMP
Alessandro La Spada

Lampada in acciaio inox con paralume a forma di foglia, ottenuta da una sottile lamina deformata a freddo, con superficie lucida a effetto "metallo liquido", internamente satinata con superficie anti-abbagliamento. Stelo centrale con sorgente luminosa a LED DS da 12W. Base in metallo con zavorra ed elemento decorativo in marmo. Le parti metalliche sono disponibili nella selezione finiture metalliche. Questo modello monta sorgenti luminose a LED a lunga durata integrate nella struttura della lampada, non sostituibili dall'utente.

Lamp in stainless steel with leaf-shaped diffuser, obtained from a thin cold-finished layer, with shiny surface with "liquid metal" effect, internally satin with anti-glare surface. Central stem with LED DS light with 12W power. Base in metal with ballast and decorative element in marble. Metal parts can be lacquered in any colour included in the metal finish selection. This model is equipped with long-life LED light sources integrated into the lamp structure, which can not be replaced by the user.

vedi anche/see also CALLIA applique-wall lamp, CALLIA lampada da tavolo-table lamp, CALLIA dehors

● click here

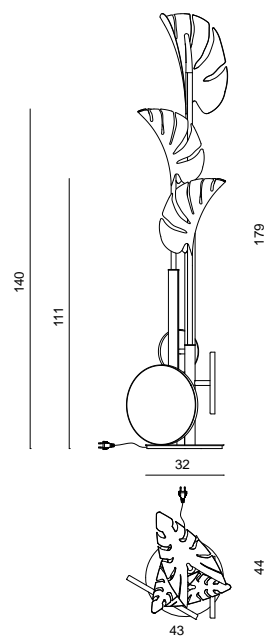

ELDER

PIANTANA - FLOOR LAMP
Fabio Bonfà

Struttura in acciaio inox satinato con inserto in legno nero lucido e base in marmo, portalampade E27 60W - 8W LED cad, paralume in tessuto intrecciato o raso nero con interno bianco. Le parti in acciaio sono disponibili nella selezione finiture metalliche satiniate.

Structure in satinized stainless steel with insert in shiny black lacquered wood and base in marble, bulb E27 60W - 8W LED each, lampshade in woven fabric or black satin with white interior. Metal parts available in the satinized metal finishing selection.

vedi anche/see also ELDER lampada da tavolo-table lamp

● click here

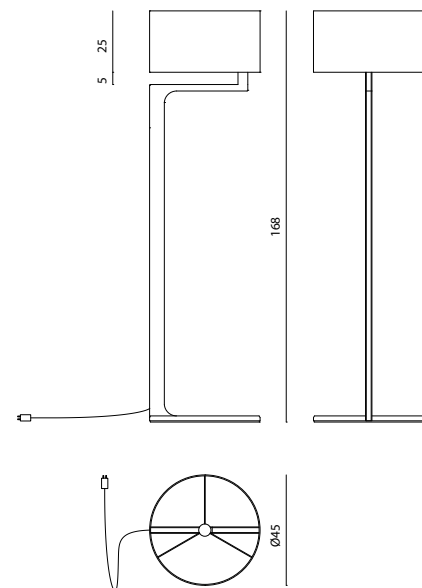

FLORO

LAMPADA DA TERRA - FLOOR LAMP
Alessandro La Spada

Struttura in ottone e acciaio, tre elementi luminosi in vetro soffiato con dispersione di foglia d'oro incastonati in un bracciale metallico. Stelo e base in acciaio. Impianto a 6 luci LED E14 8W. Le parti metalliche sono disponibili nella selezione finiture metalliche lucide.

Structure in brass and steel, three light elements in blown glass containing gold leaf particles, encased in a metal bracelet. Stem and base in steel. Lighting system consists of 6 LED bulbs E14 8W. Metal parts can be lacquered in any colour of the polish metal finish selection.

vedi anche/see also FLORO lampadario-ceiling lamp, FLORO lampada da tavolo-table lamp, FLORO applique-wall lamp

● click here

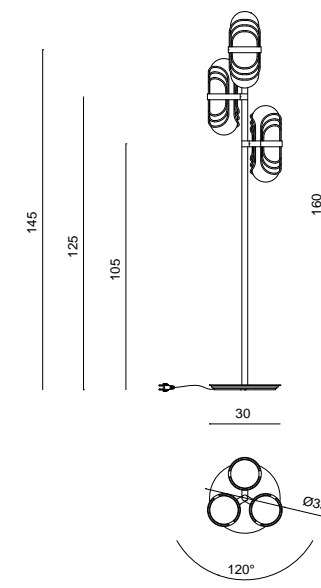

FLOYD

PIANTANA - FLOOR LAMP
Giuseppe Viganò

Struttura in acciaio satinato, diffusore in vetro offiato disponibile nelle finiture acqua/latte, acqua/ambra o tartaruga, impianto luci a LED dimmerabile 40W. Questo modello monta sorgenti luminose a LED a lunga durata integrate nella struttura della lampada, non sostituibili dall'utente

Structure in satinized steel, diffuser in blown glass available in the following finishes: water/milk, water/amber or turtle pattern. Dimmable LED lighting system, max 40W. This model is equipped with long-life LED light sources integrated into the lamp structure, which can not be replaced by the user.

● click here

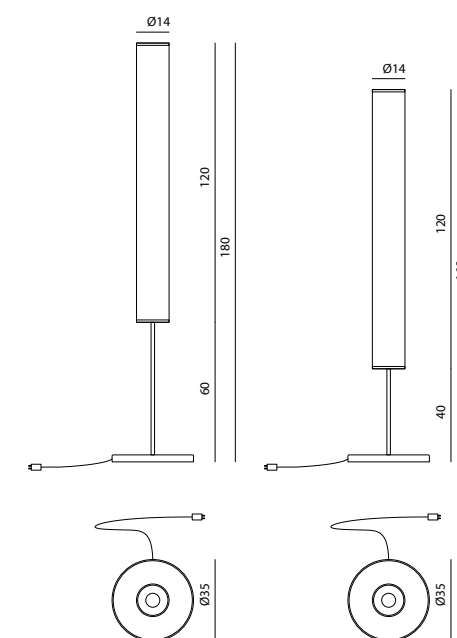



MILANO

PIANTANA - FLOOR LAMP

Armando Bruno - Alberto Torres

Piantana in marmo e acciaio. Struttura superiore in metallo con lavorazione "rigata" in bassorilievo e corpo centrale in marmo massello. Diffusore a prisma in policarbonato massello lucido con finitura interna opalina satinata. Sorgente luminosa a COB-LED 8W max. Le parti in metallo sono disponibili nella selezione finiture metalliche, il corpo centrale in marmo è disponibile monocromatico o a due colori alternati. Peso 25 kg.

Floor lamp in marble and steel. Upper part in metal with low-relief 'stripes' decoration and central body in solid marble. Prismatic diffuser in shiny solid polycarbonate with satin opaline internal finish. COB-LED light 8W max. Metal parts available in any lacquer of the metal lacquer finish selection. Central body in one or two marbles. Weight 25 kg.

vedi anche/see also MILANO lampadario-chandelier, MILANO applique-wall lamp, MILANO lampada da tavolo-table lamp

● click here

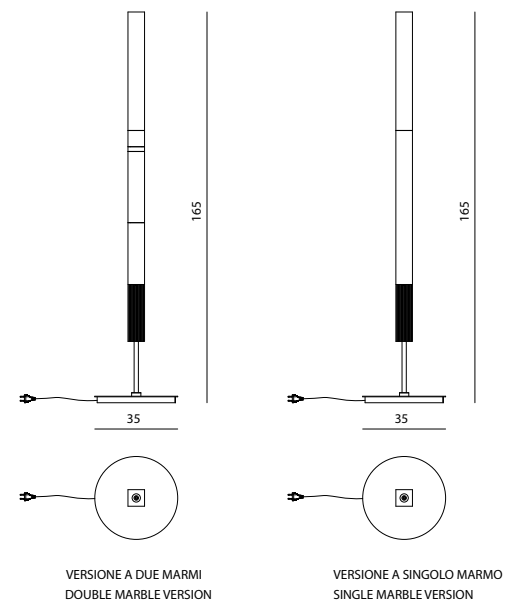

MOON-EYE

PIANTANA - FLOOR LAMP

Mauro Lipparini

Lampada da terra a una luce, struttura portante in legno massello di noce canaletto scolpito con sezione a tre lobi, con diffusore costituito da un piatto a sezione ridotta in onice o quarzite fissato alla struttura tramite staffe in metallo lucido. Portalampada in acciaio lucido con sorgente GU10 fissata al corpo in legno, cavo di alimentazione a vista in treccia di tessuto grigio, base di appoggio in acciaio lucido con zavorra anti ribaltamento in onice o quarzite. Le parti in metallo sono disponibili nella selezione finiture metalliche. Sorgente luminosa LED GU10 max 10W.

Floor lamp with one light, main structure in Canaletto walnut solid wood, with carved three-lobes section. Plate diffuser in onyx or quartzite slab connected to the structure using shiny metal brackets. Lamp holder in shiny steel with GU10 light fixed to the wooden structure, visible power cord in grey interwoven fabric, base in shiny steel with ballast in onyx or quartzite. Metal parts can be finished with any of the metal lacquer finish selection. LED GU10 max 10W light source.

vedi anche/see also MOON-EYE applique-wall lamp

● click here

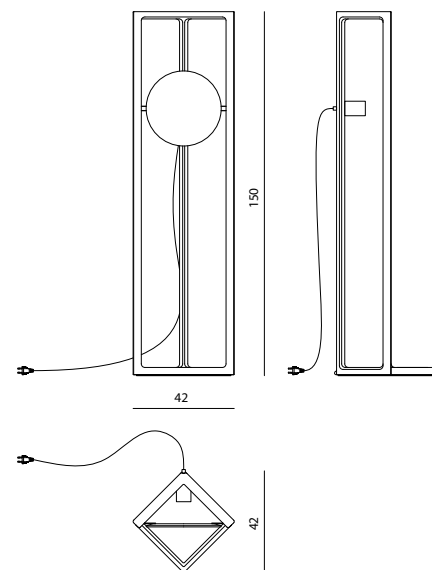

STILO

PIANTANA - FLOOR LAMP

Alessandro La Spada

Struttura in ottone rigato con tagli obliqui e finitura bicolore lucida o satinata, paralume in tessuto stampato con disegno geometrico o seta nera, portalampade E27 60W - 8W LED.

Structure in striped brass with oblique cut and shiny or satinized bicolour finishing, lampshade in printed fabric with geometric pattern or black silk, 1 bulb E27 60W - 8W LED.

vedi anche/see also STILO lampada da tavolo-table lamp

● click here

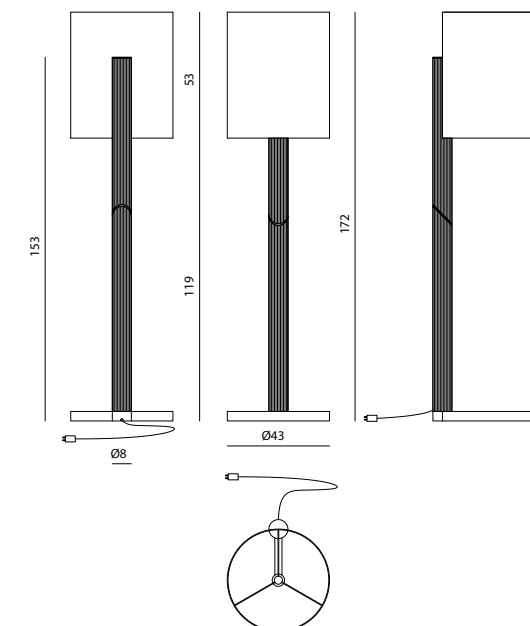

THAIS

LAMPADA DA TERRA - FLOOR LAMP

Marta Naddeo

Lampada da terra in vetro soffiato e metallo. Corpo centrale in vetro soffiato trasparente con texture "corteccia" a base quadrata con lato di 10 cm, abbinato a elementi metallici a piramide in acciaio inox contenente una luce d'ambiente (LED COB CRI90 da 4W). Diffusore cilindrico in vetro soffiato bianco Ø42 cm con sorgente LED COB CRI90 (7W). Base in acciaio con alimentatore a parete. Peso 17 kg.

Floor lamp in blown glass and metal. Central body in transparent blown glass with "bark" texture, square base with 10 cm side, combined with stainless steel pyramid metal elements containing an ambient light (4W COB CRI90 LED). Ø42 cm white blown glass cylindrical diffuser with COB CRI90 LED source (7W). Steel base with wall-mounted ballast. Weight 17 kg.

vedi anche/see also THAIS applique-wall lamp

● click here

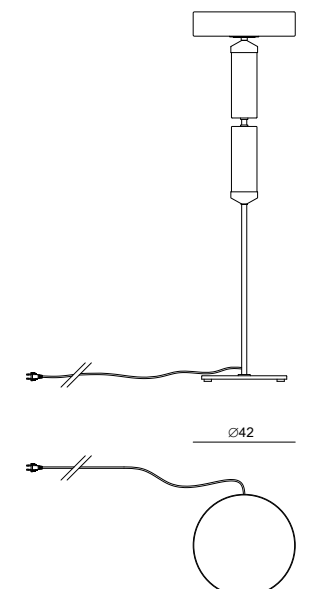



AMARILLI

PIANTANA - TRIPOD-FLOOR LAMP

Alessandro La Spada

Base in acciaio inox lucido lacca oro con zavorra in ferro. Stelo con tornerie alluminio cromo o lacca oro. Tubolari in ottone trafilato "torchon" anticato. Decorazioni taglio laser in ottone anticato. 3 lampade E27 75W - 10W LED cad. Paralume a lobi in seta nera e interno in materiale riflettente oro. Disponibile anche con paralumi con grafica "Adventures in the sea" e "Flowers&Raven".

Base in gold lacquered polished stainless steel with iron ballast. Stem with turnings in chromed or lacquered gold aluminium. Tubes in drawn antique brass "torchon". Laser-cut antiqu brass decorations. 3 lamps E27 75W - 10W LED each. Lampshade with lobes in black silk and internal in gold reflective material. Available with lampshades with "Adventures in the sea" and "Flowers & Raven" coverings.

vedi anche/see also AMARILLI lamadario-chandelier, AMARILLI lampada da tavolo-table lamp

● [click here](#)

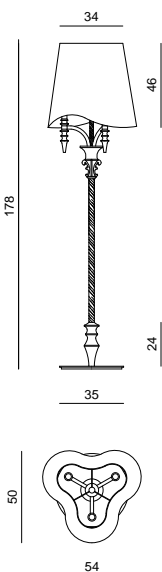

DAGONET

PIANTANA - TRIPOD-FLOOR LAMP

Alessandro La Spada - Samuele Mazza

Piantana con struttura portante a tripode a più componenti in alluminio e ottone tornito. Distanziale a 3 vie in acciaio taglio laser. Finitura cromo lucido. Paralume tronco cono in seta o in pelle Kid. Impianto elettrico predisposto per l'utilizzo di n. 3 lampadine E27 60W - 8W LED cad. Provvista di interruttore a terra con variatore d'intensità luminosa. Le parti in metallo sono disponibili nella selezione finiture metalliche satiniate.

Floor lamp with tri-pod support structure with various components in aluminium and turned brass. 3 way leg distancers in laser cut steel finished in polished chrome. Lampshade truncated cone in silk or leather Kid. Electrical system predisposed for the use of 3 light bulbs E27 60W - 8W LED each complete with floor switch for light intensity variation. Metal parts can be lacquered in any colour included in the satinized metal finish selection.

vedi anche/see also DAGONET panca-bench

● [click here](#)

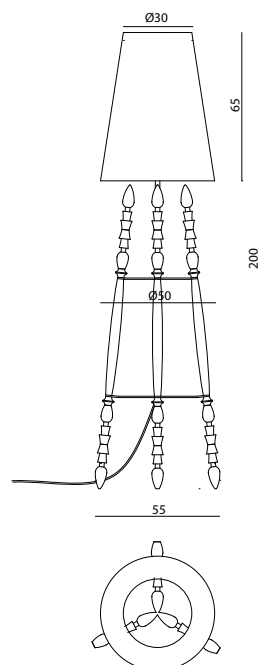

ESMERALDA

PIANTANA - FLOOR LAMP

Alessandro La Spada

Struttura in ottone finitura lucida color oro, corna tronco coniche in ottone laccato, elemento in cristallo a piombo soffiato molato, con lavorazione bugnata, finitura acidata. Paralume in tessuto nero con l'interno oro lucido, le lampadine sono E27 75W - 10W LED cad. per la versione piantana ci sono 3 lampadine. Disponibile anche con paralumi con grafica "Adventures in the sea" e "Flowers&Raven".

Structure in brass in gold shiny finishing. Half-truncated horns in lacquered brass. Lead crystal element, blown and grinded, with studded shape and frosted finishing. Lampshade in black fabric with gold internal decoration. The bulbs needed are E27 75W - 10W LED each: floor lamp - 3 bulbs. Available also with shades with graphics "Adventures in the sea" e "Flowers&Raven".

vedi anche/see also ESMERALDA lampada da tavolo-table lamp

● [click here](#)

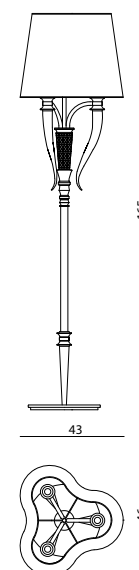

- click on the icons -



CHANTILLY p.460



CLIEF p.460



FANCY p.461



FORMA MENTIS p.461



PANAREA p.462



POLLOCK p.462



WINDSOR p.463



CHANTILLY

CACHE-POT - CACHE-POT
Alessandro La Spada

Cache-pot in ceramica con profili in oro zecchino oppure oro. Ai lati sono applicati 2 elementi decorativi a "battacchio" in ottone finitura oro o cromo. Smalto bianco o nero.

Ceramic cache-pot with outlines in pure gold. Each side has two gold-plated brass decorative knockers in golden or chrome finishing. Varnish black or white.

vedi anche/see also CHANTILLY tavoli bassi tritico-set of 3 low tables, CHANTILLY consolle-console, CHANTILLY vaso-vase, CHANTILLY piatto-plate

● click here

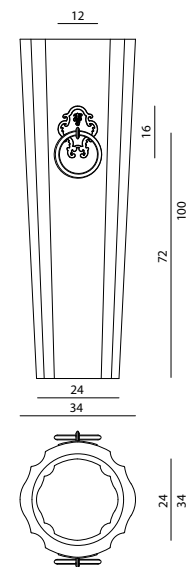

CLIEF

CACHE-POT - CACHE-POT
Samuele Mazza

Cache-pot "diamantato" in MDF rivestito in porzioni di specchio bronzo o fumé bisellate singolarmente. Parte interna laccata opaca con ripiano poggivaso. Zoccolo in MDF laccato nero lucido.

Planter with "diamond" design in MDF, coated in sections of bronze or smoked mirror, bevelled individually. Internal part with matt finishings, internal shelf for pot. Plinth in MDF lacquered in glossy black.

● click here

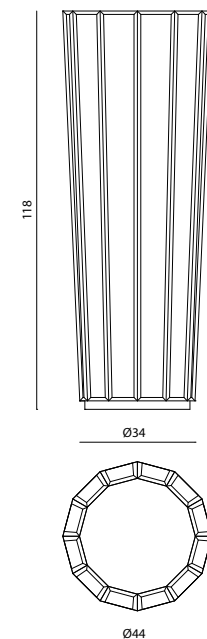

FANCY

CACHE-POT - CACHE-POT
Alessandro La Spada

Cache-pot da esterni in multistrati fenolico rivestito in pelle o tessuto da esterni, finiture metalliche in acciaio inox disponibile nella selezione finiture metalliche o nella selezione vernici a polveri. Fondo drenante per deflusso pioggia, munito di rotelle. Sconsigliato l'uso in ambienti completamente esposti alle intemperie.

Outdoor cache-pot in phenolic multilayer covered with leather or fabric for outdoor, metal parts in stainless steel available in the metal finishes selection or in the powder-coating finishes selection. Drainage system for water outflow, provided with wheels. Not recommended for use in environments completely exposed to the elements.

● click here

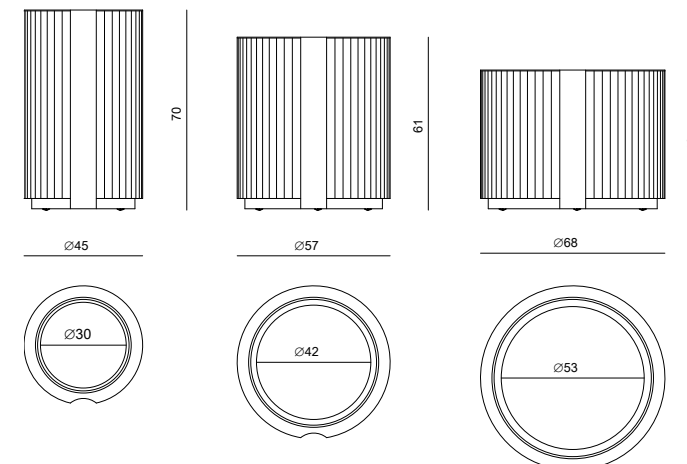

FORMA MENTIS

TESTA IN CERAMICA - HEAD IN CERAMIC
Simone Micheli

Testa in ceramica con vaschetta interna portavaso (H. 15 cm) finitura platino oppure oro lucido.

Head in ceramic with internal flower basin (H. 15 cm) finishing: platinum or gold.

vedi anche/see also FORMA MENTIS libreria-bookshelf, FORMA MENTIS specchiera-mirror, FORMA MENTIS wellness room

● click here

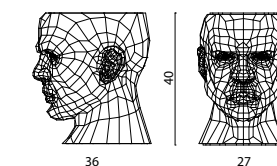



PANAREA

CACHE-POT ALTO E BASSO - HIGH AND LOW CACHE-POT
Alessandro La Spada

Struttura portante ad elementi conificati ricurvi, in alluminio con corona di raccordo finitura laccato oro. Vaso in ceramica finitura smaltata lucida con stemma araldico Visionnaire dorato.

Main structure made of curved cone chromed steel with crown connecting in gold lacquered aluminium. Vase in shiny enamelled finishing with golden Visionnaire coat of arms.

vedi anche/see also PANAREA dehors

[click here](#)

POLLOCK

CACHE-POT - CACHE-POT
Samuele Mazza

Cache-pot in legno rivestito in specchio micro-diamantato. Struttura sfaccettata con forma diamantata. Il mobile necessita attacco a parete.

Planter coated in mirror with "micro-diamond" design effect. Multi-faceted structure with diamond shape. Predisposed for wall fixing.

[click here](#)

WINDSOR

CACHE-POT - CACHE-POT
Alessandro La Spada

Cache-pot in ceramica di colore bianco o nero, con base a pianta quadrata in acciaio inox. Elementi decorativi e logo in ottone. Le parti metalliche sono disponibili nella selezione finiture metalliche.

Ceramic cache-pot in white or black polish, with square base in stainless steel and decorative details in chromed brass. Metal parts available in the metal finishing selection.

vedi anche/see also WINDSOR tavolo da pranzo-dining table, WINDSOR mobile trucco-make-up unit, WINDSOR cassetiera-chest of drawers for desk, WINDSOR scrittoio con cassetti-desk with drawers, WINDSOR vetrinetta-showcase, WINDSOR parete modulare-modular elements, WINDSOR armadio-wardrobe, WINDSOR specchiera-mirror, WINDSOR vaso-vase, WINDSOR wellness room

[click here](#)

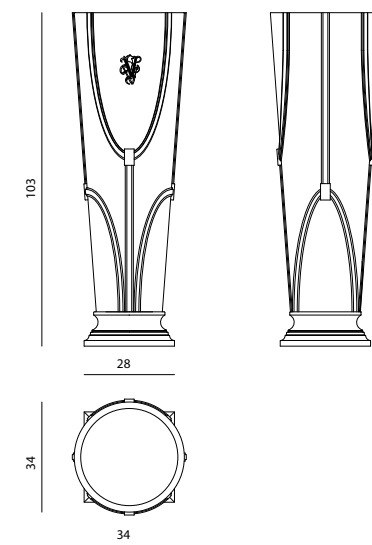
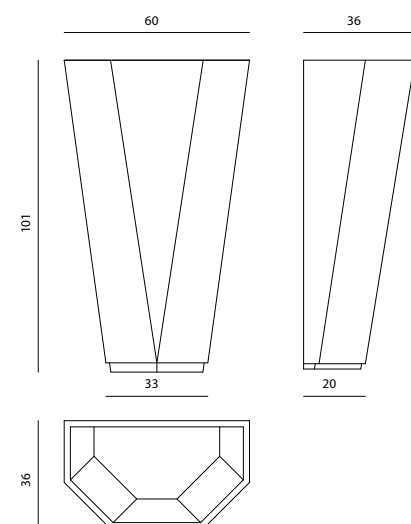
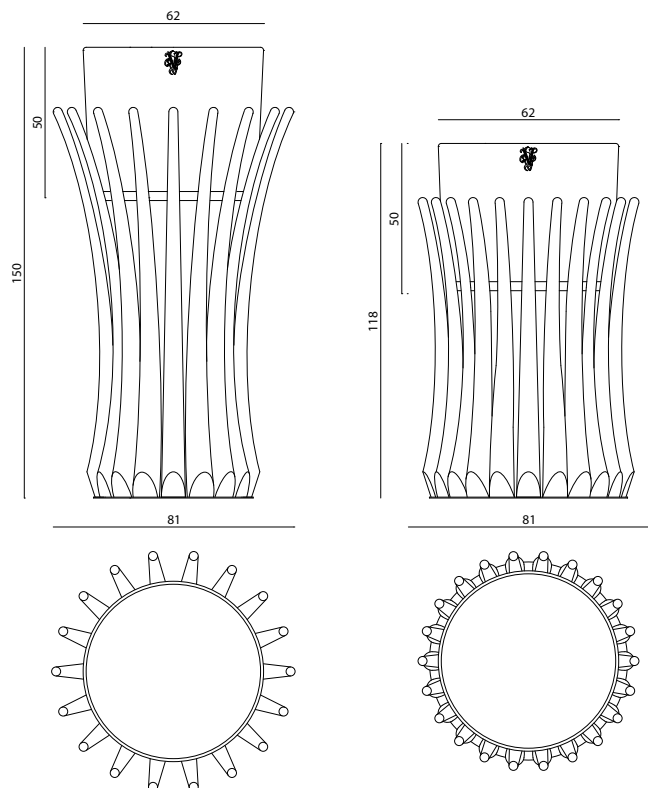

- click on the icons -

- click on the icons -



ALEXANDRITA p.466



ARABEL p.466



ARGANTE p.466



MYSTERY p.472



PERSPECTIVE DARK p.472



PERSPECTIVE LIGHT p.472



ASOKA p.467



BELAR p.467



BELISARIO p.467



PHILIDOR p.473



REGIS p.473



RÉMY p.473



BINKLEY p.468



CONWAY p.468



DEMETRE DARK p.468



RÉMY-17 p.474



RINALDO p.474



ROCK p.474



DEMETRE LIGHT p.469



EGON p.469



ENIGMA DARK p.469



SELDON p.475



TAGORA p.475



TYRION p.475



ENIGMA LIGHT p.470



ESPERYDE p.470



ESPERYDE p.470



VARIETY COLD p.476



VARIETY WARM p.476



LINDORO p.471



MALCOM p.471



MARVEL p.471

Attenzione: i colori dei tappeti possono differire rispetto alle fotografie di catalogo a causa delle tolleranze naturali sulle tonalità dei materiali utilizzati e dell'esposizione luminosa.

Attention: the colors of the carpets may differ from the photographs in the catalogue because of the natural tolerances on the shades of the materials used and the light exposure.



ALEXANDRITA

TAPPETO - CARPET

Alessandro La Spada

Tappeto in bamboo silk e lino, lavorazione manuale ad alta definizione di dettaglio. Sfumature di colore enfatizzate dalla lavorazione manuale. Backing in cotone.

Rug in bamboo silk and linen, high definition manual detailing. Colour shades emphasized by manual processing. Backing in cotton.

[click here](#)

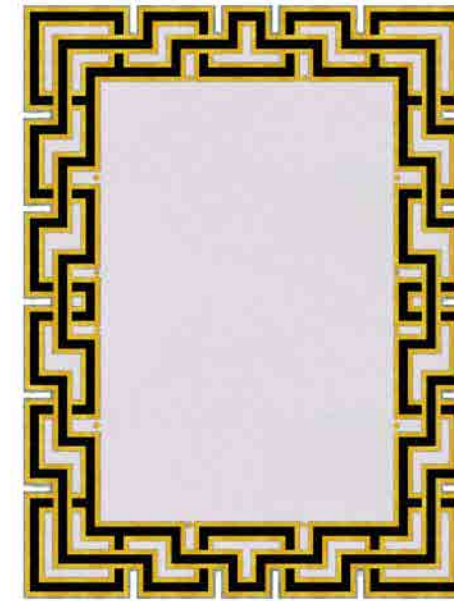
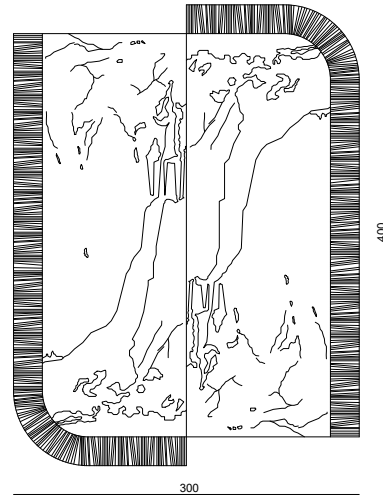

ASOKA

TAPPETO - CARPET

Samuele Mazza

Tappeto annodato a mano, 100 nodi, realizzato in Nepal con lana tibetana filata a mano, seta e viscosa. Il campo viene realizzato in tecnica "twill", lana e viscosa. La cornice nera in seta, la cornice oro-grigio in viscosa. Finitura a bassorilievo nel disegno. Forma rettangolare con bordo esterno con sagomatura "merlata".

Hand-knotted carpet, 100 knots per cm, made in Nepal with hand spun Tibet wool, silk and viscose. The central part is made with the "twill" technique, wool and viscose. The black outline is in silk, and gold-grey contour in viscose. The designed part is finished in bas-relief. Rectangular shape with external edge with "laced" contour.

[click here](#)

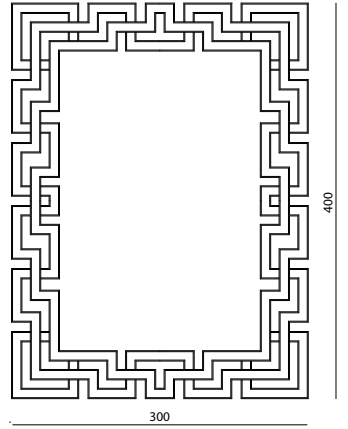

ARABEL

TAPPETO - CARPET

Giuseppe Viganò

Tappeto in bamboo silk, lavorazione manuale ad alta definizione di dettaglio.

Bamboo silk rug with manual high detailed definition handwork.

[click here](#)

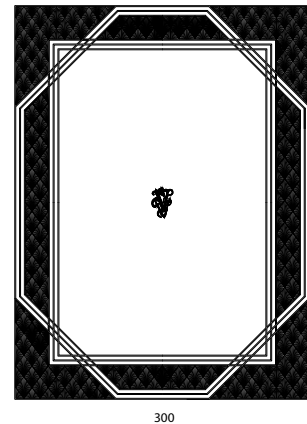

BELAR

TAPPETO - CARPET

Alessandro La Spada

Tappeto taftato a mano 100% Bamboo Silk, grafica a mosaico marmorizzato. Un angolo ospita un inserto in ottone satinato con logo Visionnaire inciso in bassorilievo. Backing in cotone.

Hand-tufted carpet. 100% bamboo silk, "marble-look mosaic" pattern. A corner contains an insert in satinized brass with Visionnaire logo engraved in bas-relief. Backing in cotton.

[click here](#)

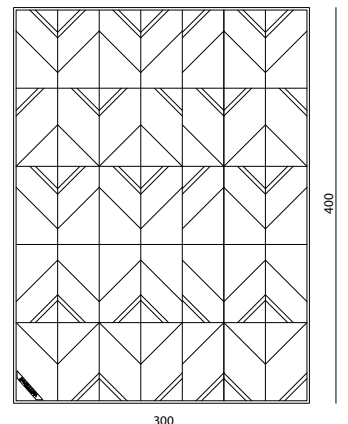

ARGANTE

TAPPETO - CARPET

Samuele Mazza

Tappeto a forma di farfalla realizzato in seta e lana tibetana annodata a mano. Corpo della farfalla di colore nero, ali di colore bianco e nero.

Butterfly shaped carpet made in silk and Tibetan wool knotted by hand. Body of butterfly in black, wings in white and black. Available in two sizes.

[click here](#)

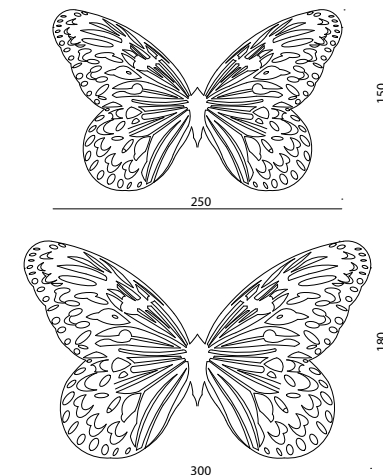

BELISARIO

TAPPETO - CARPET

Alessandro La Spada

Tappeto in bamboo silk, lavorazione manuale ad alta definizione di dettaglio. Sfumature di colore enfatizzate dalla lavorazione "carving" manuale su grafica Ca' Foscari a formare tracce in bassorilievo in lana e lurex.

Carpet in bamboo silk, hand-tufted with high attention to details. Colour shades are emphasised by the bas-relief hand-carved Ca' Foscari decoration in wool and lurex.

[click here](#)

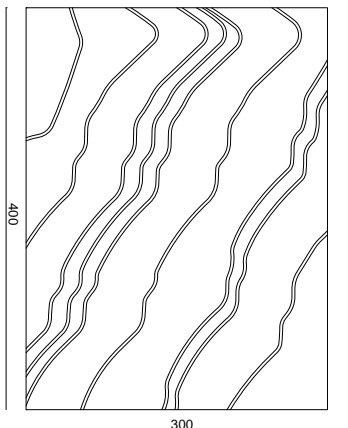



BINKLEY

TAPPETO - CARPET

La Conca

Tappeto taftato a mano in bamboosilk e lana New Zealand con lavorazione carving manuale. Backing in cotone.

Hand-tufted carpet inbamboo silk and New Zealand wool with carving work.Cotton backing.

[● click here](#)

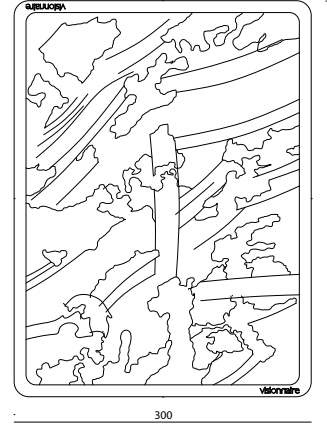

DEMETRE LIGHT

TAPPETO - CARPET

Roberto Tapinassi - Maurizio Manzoni

Tappeto in bamboo silk, lavorazione manuale ad alta definizione di dettaglio.

Bamboo silk rug with manual high detailed definition handwork.

[● click here](#)

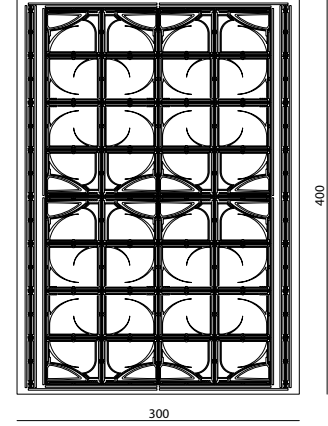

CONWAY

TAPPETO - CARPET

La Conca

Tappeto taftato a mano in bamboosilk e lana New Zealand con lavorazione carving manuale. Backing in cotone.

Hand-tufted carpet inbamboo silk and New Zealand wool with carving work.Cotton backing.

[● click here](#)

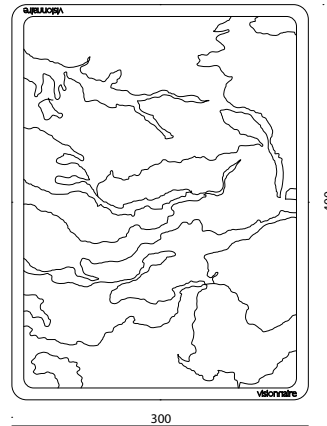

EGON

TAPPETO - CARPET

Giuseppe Viganò

Tappeto in bamboo silk, lavorazione manuale ad alta definizione di dettaglio.

Bamboo silk rug with manual high detailed definition handwork.

[● click here](#)

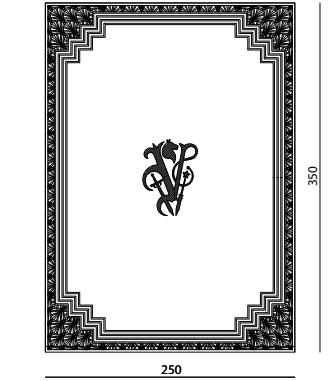

DEMETRE DARK

TAPPETO - CARPET

Roberto Tapinassi - Maurizio Manzoni

Tappeto in bamboo silk, lavorazione manuale ad alta definizione di dettaglio.

Bamboo silk rug with manual high detailed definition handwork.

[● click here](#)

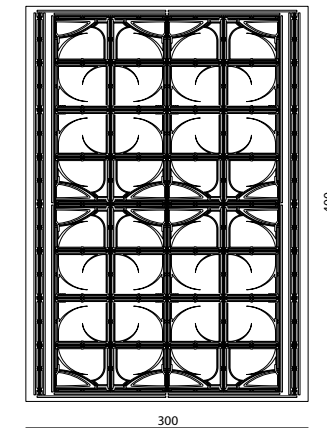

ENIGMA DARK

TAPPETO - CARPET

Alessandro La Spada

Tappeto in bamboo silk, lavorazione manuale ad alta definizione di dettaglio. Sfumature di colore enfatizzate dalla lavorazione "carving" manuale. Oltre 150 toni di colore, inserti in pura seta finissima per le sfumature più dettagliate.

Carpet in bamboo silk, handcrafted in high-definition of details, shades of color emphasized by "carving" handwork, over 150 color tones, inserts in extremely fine pure silk for more detailed shades.

[● click here](#)

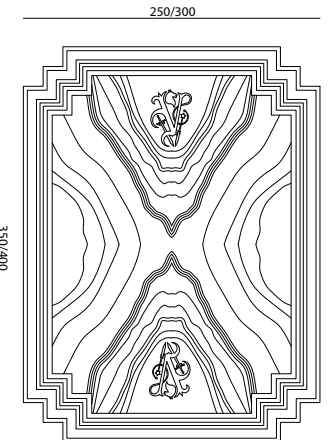



ENIGMA LIGHT

TAPPETO - CARPET

Alessandro La Spada

Tappeto in bamboo silk, lavorazione manuale ad alta definizione di dettaglio. Sfumature di colore enfatizzate dalla lavorazione "carving" manuale. Oltre 150 toni di colore, inserti in pura seta finissima per le sfumature più dettagliate.

Carpet in bamboo silk, handcrafted in high-definition of details, shades of color emphasized by "carving" handwork, over 150 color tones, inserts in extremely fine pure silk for more detailed shades.

[click here](#)

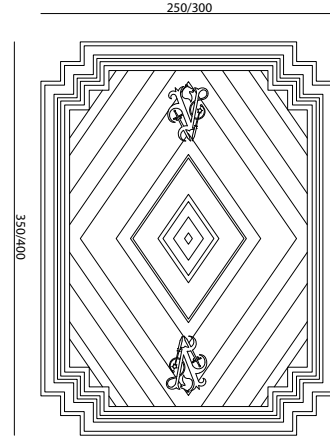

LINDORO

TAPPETO - CARPET

Alessandro La Spada

Tappeto rettangolare taftato con filati viscosa extra fine.

Rectangular tufted carpet with extra fine spun of viscose.

[click here](#)

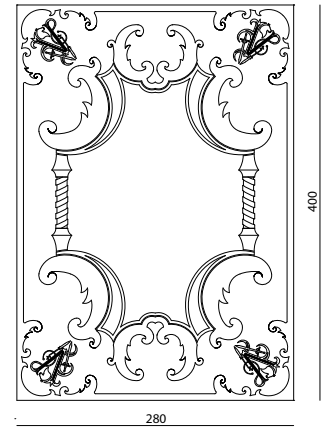

ESPERYDE

TAPPETO - CARPET

Alessandro La Spada

Tappeto taftato a mano in bamboo silk e lana New Zealand con lavorazione carving manuale. Placca in ottone ovale con incisione logo Visionnaire. Backing in cotone.

Hand-tufted carpet in bamboo silk and New Zealand wool with carving work. Metal insert with Visionnaire logo engraved in bas-relief. Cotton backing.

[click here](#)



MALCOM

TAPPETO - CARPET

La Conca

Tappeto in bamboo silk, lavorazione manuale ad alta definizione di dettaglio. Sfumature di colore enfatizzate dalla lavorazione "carving" e finiture in lana New Zealand.

Carpet in bamboo silk, hand-tufted with high attention to details. Colour shades are emphasised by the carving decoration and finishing in New Zealand wool.

[click here](#)

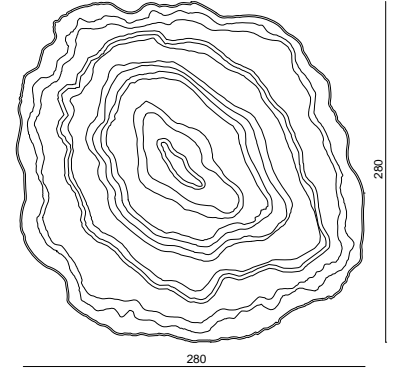

ESPERYDE

TAPPETO RETTANGOLARE -

RECTANGULAR CARPET

Alessandro La Spada

Tappeto taftato a mano in bamboo silk e lana New Zealand con lavorazione carving manuale. Placca in ottone ovale con incisione logo Visionnaire. Backing in cotone.

Hand-tufted carpet in bamboo silk and New Zealand wool with carving work. Metal insert with Visionnaire logo engraved in bas-relief. Cotton backing.

[click here](#)

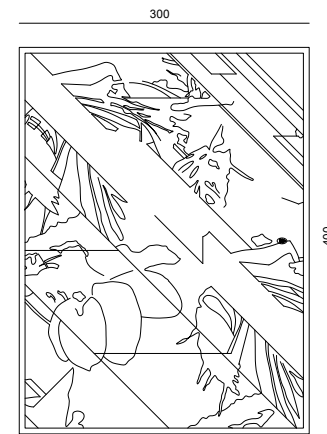

MARVEL

TAPPETO - CARPET

Alessandro La Spada

Tappeto taftato a mano 100% in Bamboo Silk, disegno a motivo marmoreo, a diverse tonalità. Gli angoli smussati ospitano quattro inserti in ottone satinato con logo Visionnaire inciso in bassorilievo. Backing in cotone.

Hand-tufted carpet, 100% Bamboo Silk. Marble-like pattern in different shades. Rounded corners with four inserts in satinized brass with Visionnaire logo engraved in bas-relief. Backing in cotton.

[click here](#)

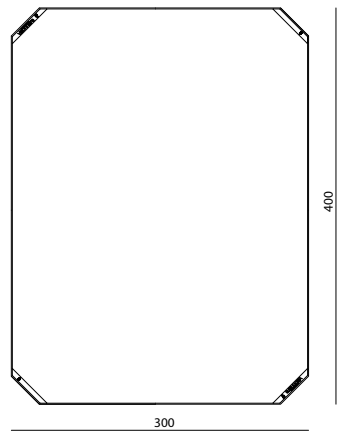



MYSTERY

TAPPETO - CARPET

Alessandro La Spada

Tappeto in lana e bamboo silk, lavorazione "carving" per il logo centrale.

Carpet in wool and bamboo silk, "carving" working for the central logo.

[● click here](#)

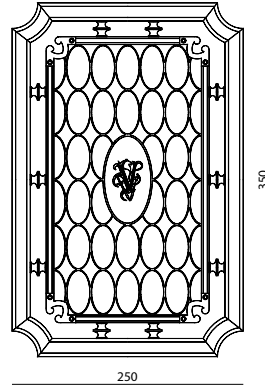

PHILIDOR

TAPPETO - CARPET

Alessandro La Spada

Tappeto in bamboo silk, lavorazione manuale ad alta definizione di dettaglio. Sfumature di colore enfatizzate dalla lavorazione "carving" manuale su grafica Ultrasound a formare tracce in bassorilievo in lana e lurex.

Carpet in bamboo silk, decorated by hand with high definition of details. Colour shades emphasised by the low-relief hand-carved Ultrasound decorative motif in wool and lurex.

[● click here](#)

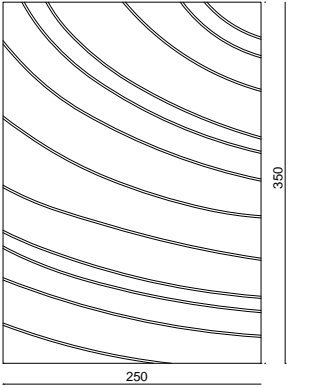

PERSPECTIVE DARK

TAPPETO - CARPET

Alessandro La Spada

Tappeto in bamboo silk e lana Mohair, lavorazione manuale ad alta definizione di dettaglio. Sfumature di colore enfatizzate dalla lavorazione manuale.

Carpet in bamboo silk and Mohair wool, handcrafted in high-definition of details, shades of color emphasized by handwork.

[● click here](#)

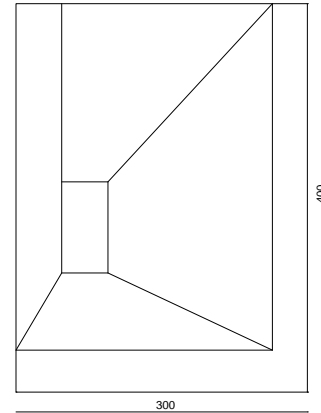

REGIS

TAPPETO - CARPET

La Conca

Tappeto taftato a mano in bamboosilk e lana New Zealand con lavorazione carving manuale. Backing in cotone.

Hand-tufted carpet in bamboo silk and New Zealand wool with carving work. Cotton backing.

[● click here](#)

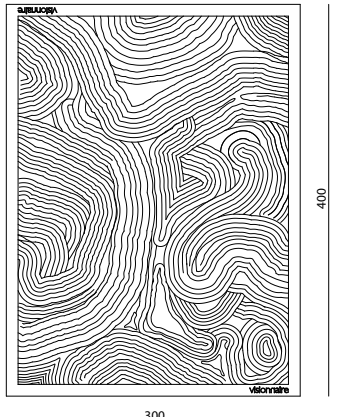

PERSPECTIVE LIGHT

TAPPETO - CARPET

Alessandro La Spada

Tappeto in bamboo silk e lana Mohair, lavorazione manuale ad alta definizione di dettaglio. Sfumature di colore enfatizzate dalla lavorazione manuale.

Carpet in bamboo silk and Mohair wool, handcrafted in high-definition of details, shades of color emphasized by handwork.

[● click here](#)

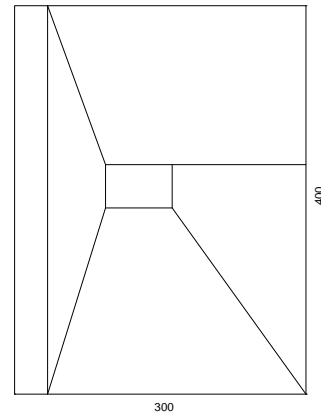

RÉMY

TAPPETO - CARPET

Alessandro La Spada

Tappeto taftato a mano 70% Bamboo Silk, 30% New Zealand Wool, disegno a motivo geometrico tono su tono. Un angolo ospita un inserto in ottone satinato con logo Visionnaire inciso in bassorilievo. Backing in cotone.

Hand-tufted carpet, 70% bamboo silk, 30% New Zealand Wool. Tone-on-tone geometrical pattern. A corner contains an insert in satinized brass with Visionnaire logo engraved in bas-relief. Backing in cotton.

[● click here](#)

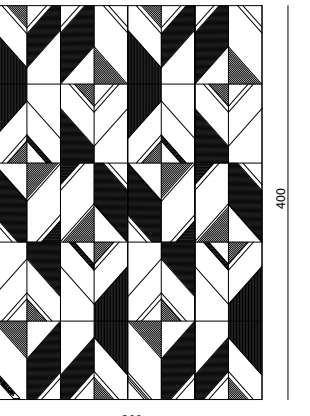



RÉMY-17

TAPPETO - CARPET

Alessandro La Spada

Tappeto taftato a mano 100% Bamboo Silk, disegno a motivo geometrico tono su tono con lavorazione in bassorilievo. Un angolo ospita un inserto in ottone satinato con logo Visionnaire inciso in bassorilievo. Backing in cotone.

Hand-tufted carpet. 100% bamboo silk. Tone-ontone geometrical pattern with bas relief work. A corner contains an insert in satinized brass with Visionnaire logo engraved in bas-relief. Backing in cotton.

● [click here](#)

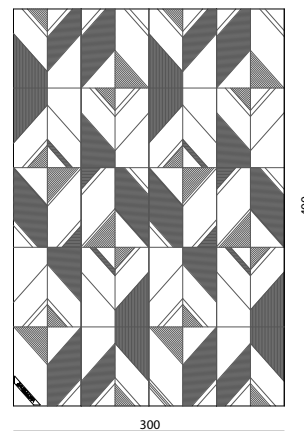

SELDON

TAPPETO - CARPET

Alessandro La Spada

Tappeto in bamboo silk, lavorazione manuale ad alta definizione di dettaglio. Sfumature di colore enfatizzate dalla lavorazione "carving" e finiture in lana new Zealand.

Carpet in bamboo silk, decorated by hand with high definition of details. Colour shades emphasised by the hand-carved decoration in New Zealand wool.

● [click here](#)

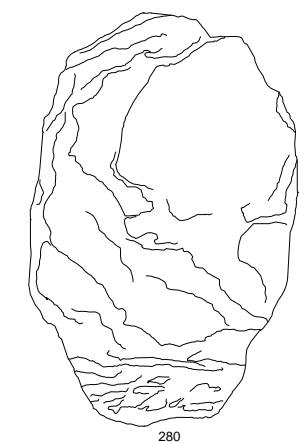

RINALDO

TAPPETO - CARPET

Alessandro La Spada

Tappeto taftato con filati viscosa extra fine. Disponibile in versione ellittica e rotonda.

Tufted carpet with extra fine spun of viscose. Available elliptical and round.

● [click here](#)

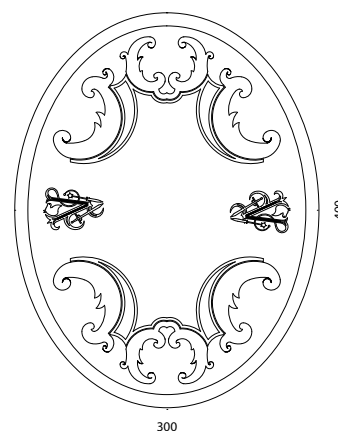

TAGORA

TAPPETO - CARPET

La Conca

Tappeto taftato a mano in bamboosilk e lana New Zealand con lavorazione carving manuale. Backing in cotone.

Hand-tufted carpet in bamboo silk and New Zealand wool with carving work. Cotton backing.

● [click here](#)

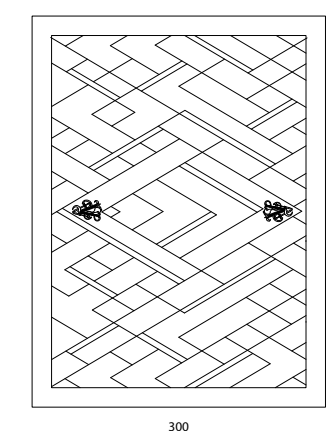

ROCK

TAPPETO - CARPET

Alessandro La Spada

Tappeto in bamboo silk, lavorazione manuale ad alta definizione di dettaglio. Sfumature di colore enfatizzate dalla lavorazione manuale. Backing in cotone.

Rug in bamboo silk and linen, high definition manual detailing. Colour shades emphasized by manual processing. Backing in cotton.

● [click here](#)

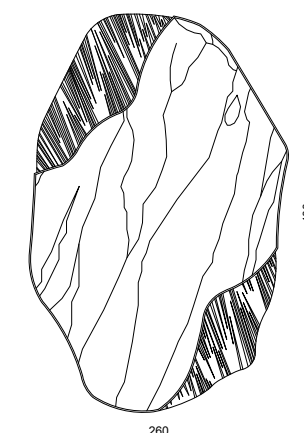

TYRION

TAPPETO - CARPET

La Conca

Tappeto taftato a mano in bamboosilk e lana New Zealand con lavorazione carving manuale. Backing in cotone.

Hand-tufted carpet in bamboo silk and New Zealand wool with carving work. Cotton backing.

● [click here](#)

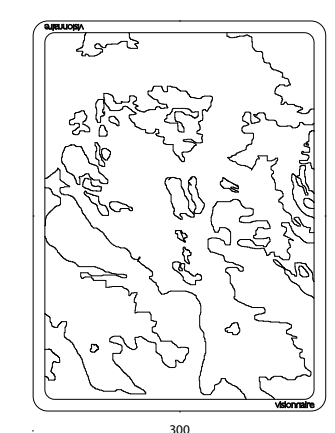



VARIETY COLD

TAPPETO - CARPET

Samuele Mazza

Tappeto taftato a mano 100% in seta, disegno a motivo geometrico ottagonale a due toni. A richiesta sul perimetro è inserita una catena decorativa in metallo cromato. Backing in cotone. Disponibile nelle versioni cromatiche "cold" e "warm".

Hand-tufted carpet. 100% silk, octagonal-geometrical pattern in 2 shades. Upon request, it is possible to finish the perimeter with a decorative chain in chromed metal. Backing in cotton. Available in two tone versions: "cold" and "warm".

[● click here](#)

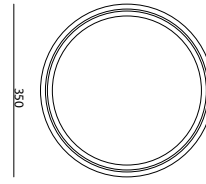
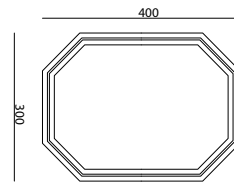
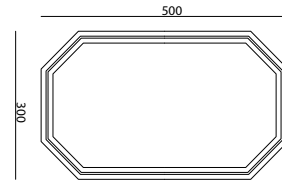

VARIETY WARM

TAPPETO - CARPET

Samuele Mazza

Tappeto taftato a mano 100% in seta, disegno a motivo geometrico ottagonale a due toni. A richiesta sul perimetro è inserita una catena decorativa in metallo cromato. Backing in cotone. Disponibile nelle versioni cromatiche "cold" e "warm".

Hand-tufted carpet. 100% silk, octagonal-geometrical pattern in 2 shades. Upon request, it is possible to finish the perimeter with a decorative chain in chromed metal. Backing in cotton. Available in two tone versions: "cold" and "warm".

[● click here](#)

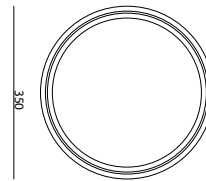
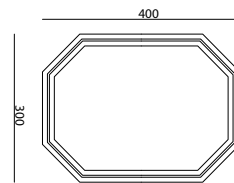
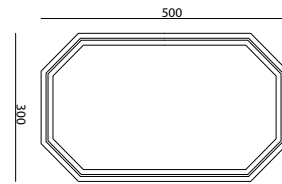

- click on the icons -



ARCHIMEDE p.480



FORMA MENTIS p.481



HARMONY p.482



RAGTIME p.482



LEONARDO p.483



HARMONY p.484



KOBOL p.486



MARIENBAD p.488



PLEASURE p.489

ICONICI - *ICONIC*



GRIMILDE SINGOLA p.490



PORTOROSE p.491



WINDSOR p.492



ARCHIMEDE

COLONNA BAGNO
TOILETRIES COLUMN
Alessandro La Spada

Colonna toilette rotante disponibile con mano destra o sinistra. Struttura in legno con lati curvi scolpiti con lavorazione superficiale canneté in bassorilievo disponibile con finitura verniciata lucida nelle tinte RAL/NCS o metallizzate a campionario. Base e profilo sotto-top e un montante concavo rivestiti in acciaio inox lucido curvato in porzioni concave e convesse. Interni laccati con colori RAL/NCS opaco e ripiani in cristallo. Base rotante in acciaio inox e profili decorativi disponibili nella selezione finiture metalliche. Attacco a parete predisposto per rotazione e accesso al vano interno.

Swivel toiletries column available in right or left version. Wooden structure with curved sides decorated with 'canneté' stripes carved in low relief, available in polished lacquered finish in the RAL/NCS colours or metallic lacquers available in collection. Base and profile under top and a concave upright in polished stainless steel curved in concave and convex portions. Lacquered interiors with opaque RAL/NCS colours and crystal shelves. Swivel base in stainless steel and decorative profiles available in the metal finishes selection. Wall fixing system predisposed for rotation and access to the internal compartment.

● click here

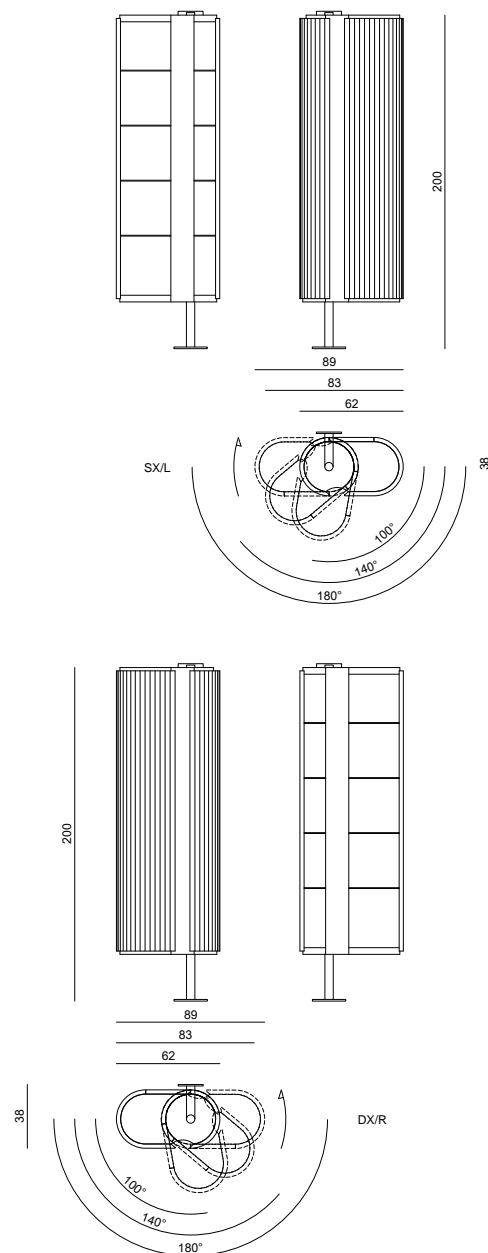

FORMA MENTIS

LAVABO SINGOLO, MOBILE PORTALAVABO E LAVABO
SINGLE BASIN, CONSOLE WITH BASIN
Simone Micheli

Struttura in MDF finitura laccata lucida. Cassetto con apertura push-pull, con logo in acciaio inox annegato nella laccatura. Zoccolo laccato finitura lucida. Lavabo in ceramica a forma di testa, con scarico piletta up down, disponibile in finitura interna bianca ed esterna oro o in finitura interna bianca ed esterna platino. Disponibile in versione con testa orientata verso sx o verso dx. Miscelatore ed erogatore ad incasso a parete in acciaio inox.

Structure in MDF, shiny polished lacquered finish. Drawer with push-pull opening, with lacquered stainless steel logo. Plinth lacquered gloss finish. Basin in head-shape ceramic, with up-down drainage system, available in internal white finish and gold external finish or internal white finish and external platinum finish. Available with head right or left oriented. Tap with monocontrol mixer fixed to the wall.

ELEMENTO CONTENITORE A TERRA - FLOOR STORAGE UNIT

Struttura in MDF finitura laccata lucida. Cassetto con apertura push-pull, con logo in acciaio inox annegato nella laccatura e zoccolo laccato finitura lucida.

Structure in MDF, shiny polished lacquered finish. Drawer with push-pull opening, with stainless steel logo. Plinth lacquered gloss finish.

ELEMENTO CONTENITORE PENSILE - WALL STORAGE UNIT

Struttura in MDF finitura laccata lucida. Cassetto con apertura push-pull, con logo in acciaio inox annegato nella laccatura. Predisposizione per montaggio porta salviette in ottone Cromato lucido. Disponibile in versione dx e sx.

Structure in MDF, shiny polished lacquered finish. Drawer with push-pull opening, with stainless steel logo. Plinth in shiny stainless steel laminate. Predisposed for fixing of towel hanger in chromed brass. Available in right or left version.

SPECCHIERA - MIRROR

Struttura cornice in acciaio inox finitura lucida con lavorazione a diamante distanziata dal muro da un profilo in acciaio inox finitura lucida. Parte centrale in specchio a incasso nella struttura. Retro cornice illuminata da illuminazione LED.

Main structure in shiny stainless steel with diamond finishing, separated from wall by a shiny stainless steel frame. Central part of the mirror built in the structure. Back frame with LED lighting.

vedi anche/see also FORMA MENTIS libreria-bookshelf, FORMA MENTIS specchio-mirror, FORMA MENTIS vaso-head in ceramic

● click here

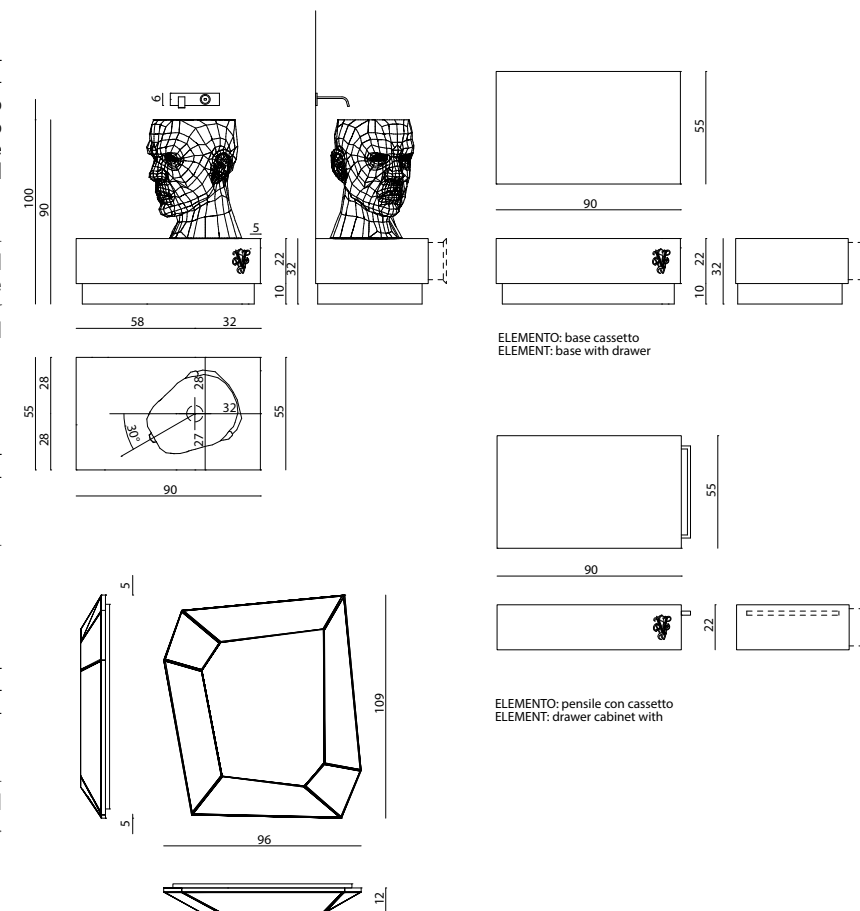



HARMONY

PORTA ASCIUGAMANI - TOWEL HOLDER
Alessandro La Spada

Struttura in acciaio inox satinato con piano d'appoggio in marmo. Le parti metalliche sono disponibili nella selezione finiture metalliche satinate.

Structure in satinized stainless steel with support surface in marble. Metal parts available in the satinized metal finishing selection.

APPENDIABITI DA PARETE - CLOTHES HANGER
Alessandro La Spada

Cornice in acciaio inox satinato con inserto in marmo. Le parti metalliche sono disponibili nella selezione finiture metalliche satinate.

Frame in satinized stainless steel with marble insert. Metal parts available in the satinized metal finishing selection.

● click here

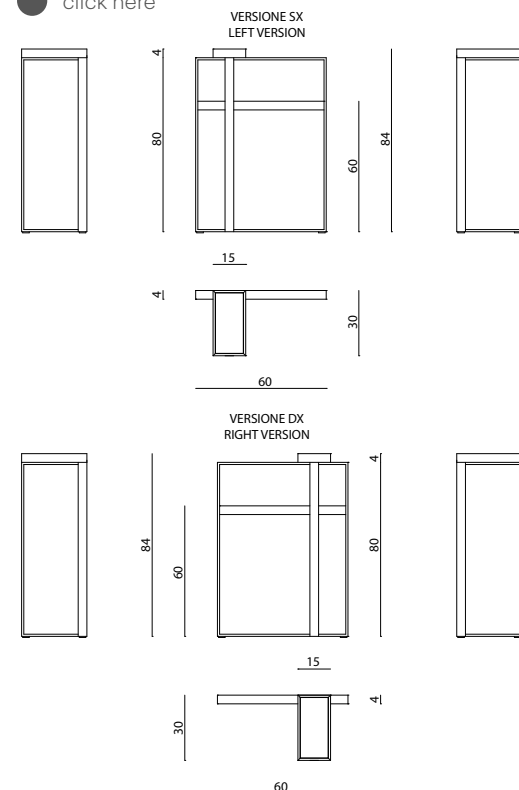

RAGTIME

SET ASCIUGAMANI, TELO DOCCIA, ACCAPPATOIO
SET OF TOWEL, SHOWER TOWEL, BATHROBE
La Conca

Abbigliamento bagno, in spugna 480gr. Disponibile nei colori bianco (con ricamo nero) oppure nero (con ricamo bianco).

Bathroom clothing, Terry cloth 480 gr. Available in white (with black Visionnaire logo) and black (with white logo).

● click here

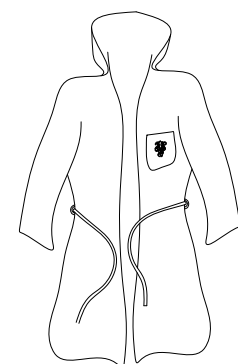
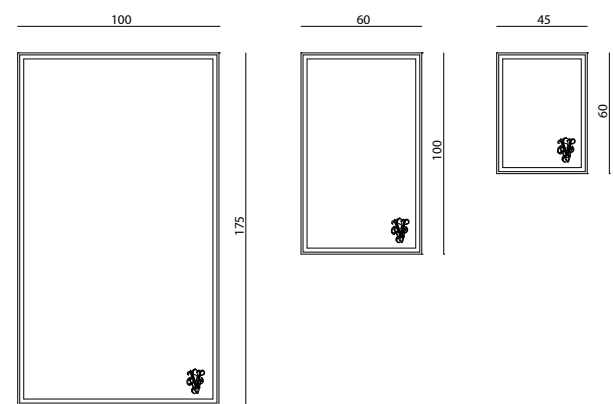

LEONARDO

CONSOLE PORTALAVABO - WELLNESS UNIT
Alessandro La Spada

Console da toilette con uno o due lavabi, mobile ad ante curve e due cestoni estraibili. Struttura in legno composta da un profilo sotto-top e un montante rivestiti in acciaio inox lucido curvato. Ante e fianchi curvi scolpiti con lavorazione superficiale "canneté" in bassorilievo, disponibili con verniciatura lucida (tinte RAL/NCS), oppure in colori metallizzati a campionario. Top in marmo sagomato con profilo bisellato in negativo. I rubinetti e l'erogatore dell'acqua sono realizzati in ottone massiccio cromato. Lavabo in ceramica smaltata bianca. Fissaggio a parete. Interni laccati opaco. Le parti metalliche sono disponibili nella selezione finiture metalliche. Il top è disponibile in marmi selezionati anche con finitura antimacchia Azerocare.

Wellness unit with one or two basins. Unit with curved doors and two pull-out basket drawers. Structure in wood composed by undertop profile and sustaining frame in curved stainless steel. Doors and sides decorated with hand-carved canneté motif in low relief. They can be lacquered with polish finish in RAL/NCS colours or in metal colours as per sampler. Top in shaped marble with contrasting bevelled profile. Taps and faucet in chromed solid brass. Basin in enamelled white ceramic. Metal parts available with any finish included in the metal finish selection. Wall fixing. Top available in marbles also treated with Azerocare anti-stain treatment.

vedi anche/see also LEONARDO letto-bed, LEONARDO comodino-bedside table, LEONARDO cassetiera-chest of drawers, LEONARDO media-high unit, LEONARDO mobile basso-low unit, LEONARDO mobile bar-bar unit, LEONARDO libreria-bookshelf, LEONARDO armadio-wardrobe



● click here

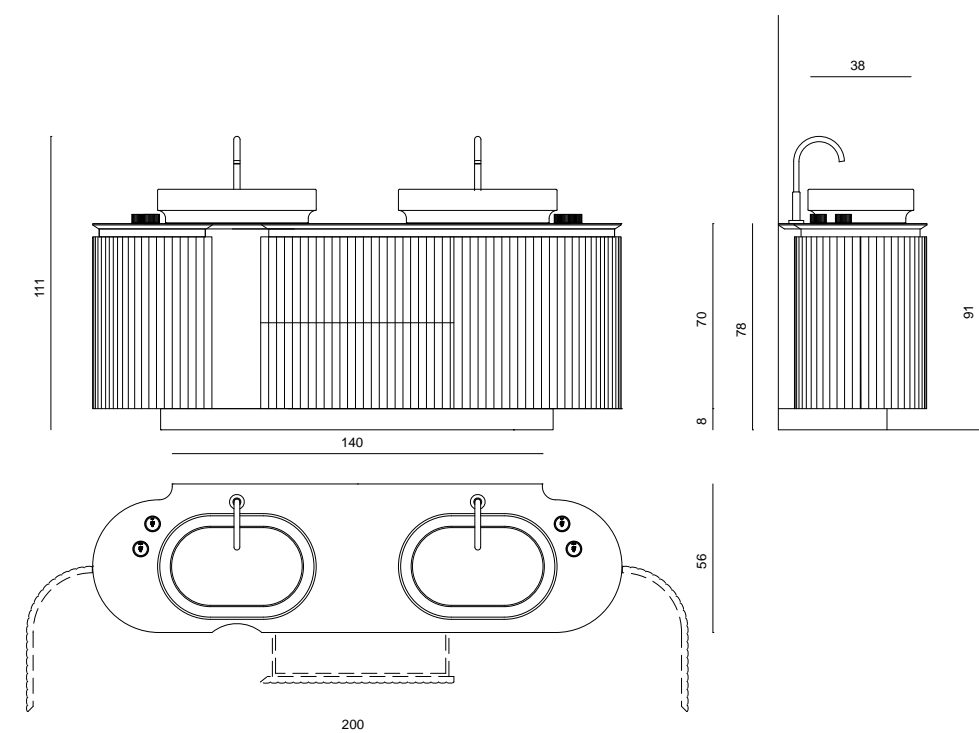



HARMONY

MOBILE PORTA 2 LAVABI,
MOBILE PORTA LAVABO SINGOLO, SPECCHIERA
CONSOLE WITH 2 BASINS,
CONSOLE WITH SINGLE BASIN, MIRROR
Alessandro La Spada

Struttura in legno multistrati marino con cestoni e sponde in vetro/acciaio a guide smorzate. Cassetti interni in legno laccato opaco, frontali e fianchi in marmo lavorato per incisione in bassorilievo con disegno geometrico e bordi superiori rivestiti in acciaio inox satinato. Piedi in acciaio inox satinato. Top e lavello in marmo scolpito dal massello in pezzo unico. Rubinetteria disponibile nelle finiture cromo, bronzo e nickel nero lucidi, canna di fucile patinato e Siena satinato. Specchiera con inserto in marmo e acciaio inox satinato con logo Visionnaire inciso, bordi esterni in acciaio inox satinato. Le parti metalliche sono disponibili nella selezione finiture metalliche satiniate.

Structure in marine plywood panels with basket drawers and sides in glass/steel with damped rails. Internal drawers in mat lacquered wood, front and sides in marble with geometric pattern in bas-relief engraving and upper borders covered with satinized stainless steel. Feet in satinized stainless steel. Top and basin in marble obtained from solid marble in one single piece. Taps available in: shiny chrome, shiny bronze, shiny black nickel, patinated gunmetal, satinized Siena. Mirror with insert in marble and satinized stainless steel with engraved Visionnaire logo, external borders in satinized stainless steel. Metal parts available in the satinized metal finishing selection.

● [click here](#)

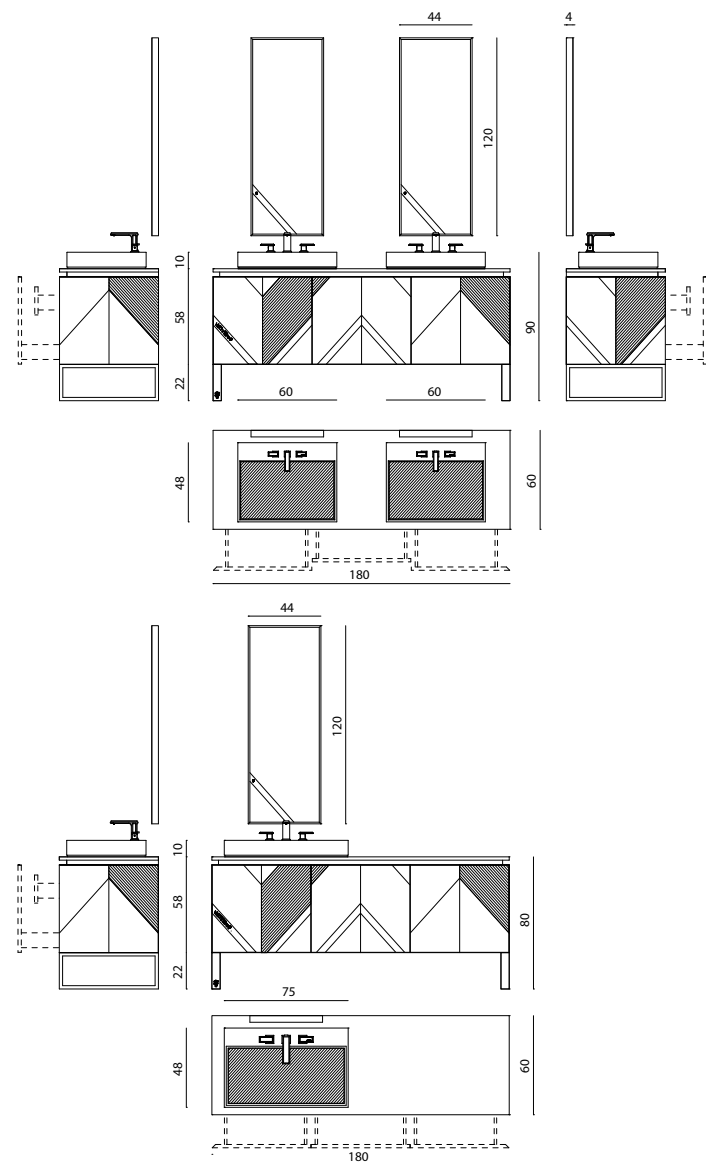

HARMONY

MOBILE PORTA LAVABO SINGOLO
CONSOLE WITH LEGS SINGLE BASIN
Alessandro La Spada

Struttura in legno multistrati marino con cestoni e sponde in vetro/acciaio a guide smorzate. Cassetto interno in legno laccato opaco, frontale e fianchi in marmo lavorato per incisione in bassorilievo con disegno geometrico e bordi superiori rivestiti in acciaio inox satinato. Piedi in acciaio inox satinato. Lavello in marmo scolpito dal massello in pezzo unico. Rubinetteria disponibile nelle finiture cromo, bronzo e nickel nero lucidi, canna di fucile patinato e Siena satinato. Specchiera con inserto in marmo ed inserto in acciaio inox satinato con logo Visionnaire inciso, bordi esterni in acciaio inox satinato. Disponibile anche in versione pensile. Le parti metalliche sono disponibili nella selezione finiture metalliche satiniate.

Structure in marine plywood panels with basket drawers and sides in glass/steel with damped rails. Internal drawer in mat lacquered wood, front and sides in marble with geometric pattern in bas-relief engraving and upper borders covered with satinized stainless steel. Feet in satinized stainless steel. Basin in marble obtained from solid marble in one single piece. Taps available in: shiny chrome, shiny bronze, shiny black nickel, patinated gunmetal, satinized Siena. Mirror with insert in marble and insert in satinized stainless steel with engraved Visionnaire logo, external borders in satinized stainless steel. Available also in wall-mounted version. Metal parts available in the metal finishing selection.

● [click here](#)

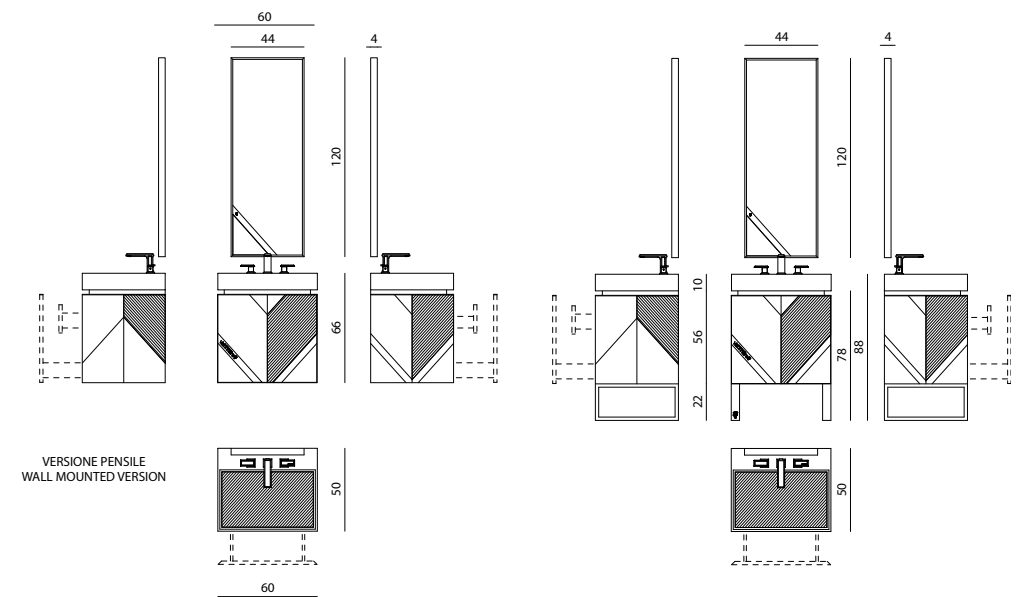



KOBOL

MOBILE PORTALAVABO - CONSOLE WITH BASIN

Alessandro La Spada

Console da toilette con due lavabi, mobile in legno con due cassetti provvisto di alzata laterale e posteriore in legno massello scolpito in bassorilievo con lavorazione "canneté", internamente rivestita in acciaio inox satinato. Top in marmo sciolto con parte posteriore rialzata a supporto della rubinetteria. I rubinetti ed erogatore dell'acqua sono realizzati in ottone massiccio cromato. Lavabo in ceramica smaltata con esterno bianco oppure smaltato oro o platino, provvisto di piatto copri scarico in ceramica. Struttura portante in acciaio inox satinato, provvista di ripiano porta salviette in vetro o marmo. Predisposto per fissaggio a parete. Disponibile versione console con lavabo singolo. Le parti in legno sono disponibili anche in finitura laccata lucida. Le parti in metallo sono disponibili nella selezione finiture metalliche.

Console with two washbasins, wooden cabinet with two drawers with side and back in solid wood carved in bas-relief with "canneté" processing, internally covered in satin stainless steel. Boxed marble top with raised rear part to support the taps. The faucets and the knobs are made of solid chromed brass. Glazed ceramic washbasin with white, gold or platinum enamelled exterior, provided with ceramic drain plate. Structure in brushed stainless steel, equipped with glass or marble towel shelf. Prepared for wall mounting. Available console version with single washbasin. Wooden parts are also available in polished lacquered finish. Metal parts available in the metal finishing selection.

Winner of the 2018 Archiproducts Design Awards, "Bathroom" category

vedi anche/see also KOBOL mobile trucco-make-up unit

click here



KOBOL

SPECCHIO - MIRROR

Alessandro La Spada

Specchio a posizionamento verticale con bordo molato e schienale in legno nero. Tre elementi decorativi in ottone satinato lungo il perimetro.

Vertical mirror with ground edge and black wood back. Three decorative elements in satin brass along the perimeter.

PORTA ASCIUGAMANI - TOWEL HOLDER

Portasciugamani in acciaio inox satinato con port oggetti in marmo.

Satin stainless steel towel rail with marble storage rack.

ACCESSORI BAGNO - ACCESSORIES

Linea di accessori in ceramica rigata con dettagli in acciaio inox e ottone satinato, composta da bicchiere quadrato, dispenser sapone, contenitore rettangolare con coperchio e con griglia.

Line of accessories in striped ceramic with details in stainless steel and satin brass, composed of square box, soap dispenser, rectangular container with lid and with grill.

vedi anche/see also KOBOL mobile trucco-make-up unit

click here

SPECCHIO - MIRROR

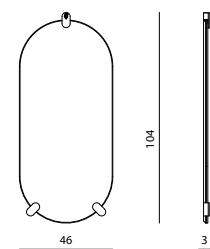

COVER GRANDE COVER "BIG"

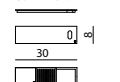

COVER PICCOLA COVER "SMALL"

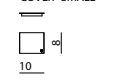

SCATOLA MULTIUSO MULTIPURPOSE BOX

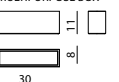

SCATOLA SINGOLA SINGLE BOX

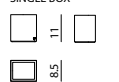

CONTENITORE SAPONE SOAP DISPENSER

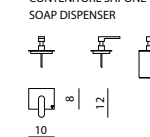

COVER SAPONE SOAP COVER



PORTA ASCIUGAMANI TOWEL HOLDER

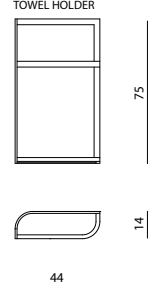

VERSIONE SX LEFT VERSION

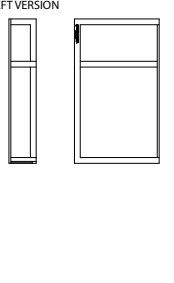

VERSIONE DX RIGHT VERSION

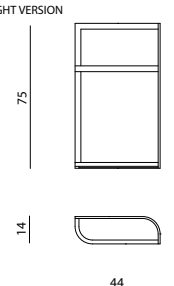



MARIENBAD

CONSOLLE PORTA LAVABO - CONSOLE WASH-BASIN

Alessandro La Spada - Samuele Mazza

Consolle porta lavabo singolo con specchio, 1 anta (dx o sx) e 1 ripiano interno. Consolle porta lavabo doppio con specchio, 4 ante (dx e sx) e 2 ripiani interni. Struttura in multistrati con lavorazione dei bordi a bisello. Laccatura esterna finitura lucida idrorepellente. Interno e ripiano laccati opachi. Specchio con cornice in multistrati laccato lucido idrorepellente. Miscelatore monocomando a parete. Lavabo a catino soprapiano in ceramica con personalizzazione stemma araldico Visionnaire, disponibile nelle versioni:

- LA finitura esterna in smalto platino lucido
- LB finitura esterna in smalto oro lucido
- LC finitura esterna in smalto bianco lucido

Maniglia in alluminio tornito, cromato finitura lucida, disponibile nel disegno:

- A con punte / - B bamboo / - C oval

Piede nella versione:

- In alluminio tornito finitura cromo lucido (A)
- In acciaio inox taglio laser (B)

Console single wash-basin with mirror, 1 door (R or L) and 1 internal shelf. Console double wash-basin with mirror, 4 doors (R and L) and 2 internal shelves. Structure in plywood with bevelled border workmanship. External lacquering in gloss water-repellent finish. Internal and shelf lacquered opaque. Mirror with frame in plywood lacquered gloss water-repellent. Monocomand mixer taps on wall. Bowl shaped basins above plane in ceramic with personalized Visionnaire coat of arms available in the versions:

- LA external finish in polished platinum enamel
- LB external finish in polished gold enamel
- LC external finish in polished white enamel

Handles in turned aluminium, polished chrome finish, available in design:

- A with points / - B bamboo / - C oval

Feet available version:

- Aluminium turned feet, chrome finish (A)
- Stainless steel laser cut (B)

COLONNA CONTENITORE - COLUMN UNIT

Colonna contenitore con anta singola / doppia. Struttura in multistrati con lavorazione dei bordi a bisello. Laccatura esterna finitura lucida idrorepellente. Interno e ripiani laccati opachi. Maniglia in alluminio tornito, cromato finitura lucida, disponibile nel disegno:

- A con punte / - B bamboo / - C oval

Piede nella versione:

- In alluminio tornito finitura cromo lucido (A)
- In acciaio inox taglio laser (B)

Structure in plywood with bevelled border workmanship. External lacquering in gloss water-repellent finish. Internal and shelf lacquered opaque. Handle in turned aluminium, polished chrome finish, available in design:

- A with points / - B bamboo / - C oval

Feet available version:

- Aluminium turned feet, chrome finish (A)
- Stainless steel laser cut (B)

[click here](#)

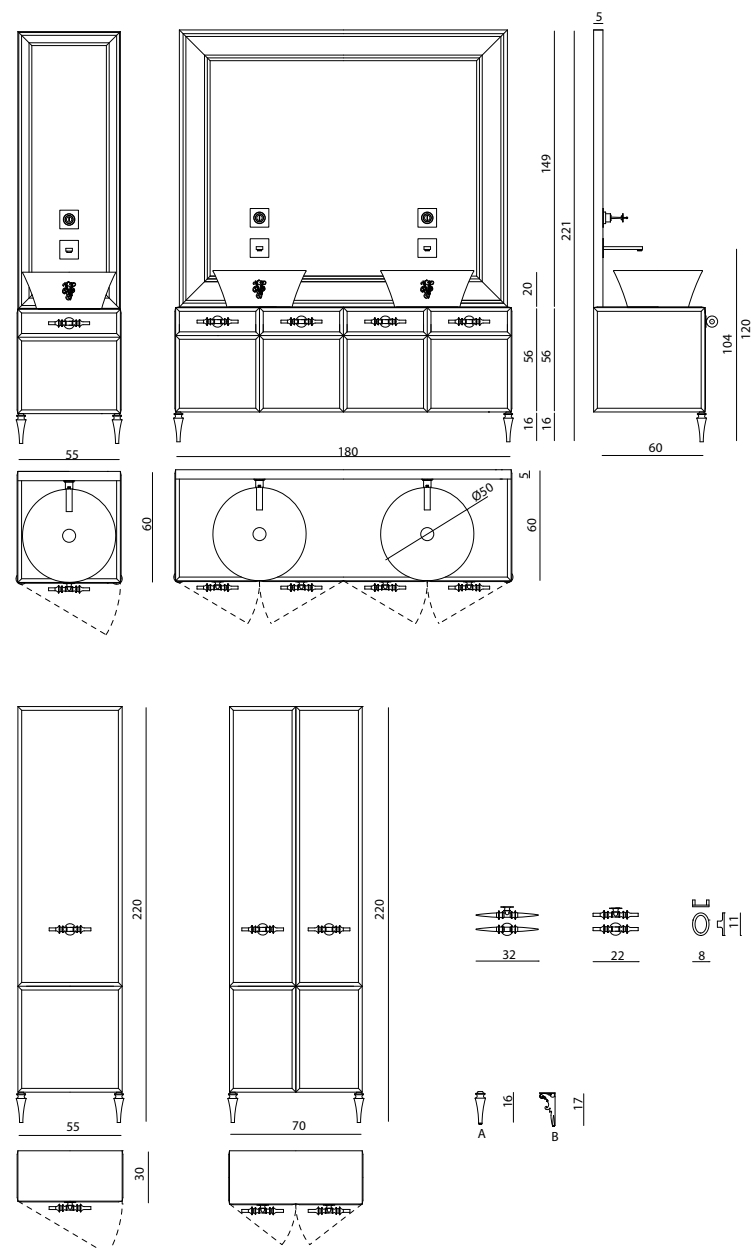

PLEASURE

MOBILE PORTALAVABO - CONSOLE WITH BASIN

Alessandro La Spada

Consolle da bagno in legno laccato con lavorazione superficiale scolpita con trama geometrica, top in marmo con lavabo in Corian colore glacier white o clay e rubinetteria in ottone satinato e marmo. Inserti decorativi in acciaio e marmo. Struttura in legno multistrati marino con cestoni e sponde in vetro e acciaio a guide smorzate. Cassetti interni in legno laccato opaco. Piedi in acciaio inox satinato. Specchiera con inserto in marmo e acciaio inox satinato con logo Visionnaire inciso, bordi esterni in acciaio inox satinato. Disponibile in versione a lavabo singolo o doppio. Le parti in metallo sono disponibili nella selezione finiture metalliche satinato.

Washbasin console in lacquered wood, decorated with carved geometric pattern. Top in marble with Corian washbasin available in glacier white or clay colour, taps in satin brass and marble. Decorative inserts in steel and marble. Structure in marine plywood with basket drawers, sides in glass and steel, damper drawer slides. Internal drawers in wood with matt lacquer finish. Feet in satin stainless steel. Mirror with marble insert and satin stainless steel with engraved Visionnaire logo. External profiles in satin stainless steel. Available with one or two washbasins. Metal components can be finished with any lacquer of the metal satinized finish selection.

[click here](#)

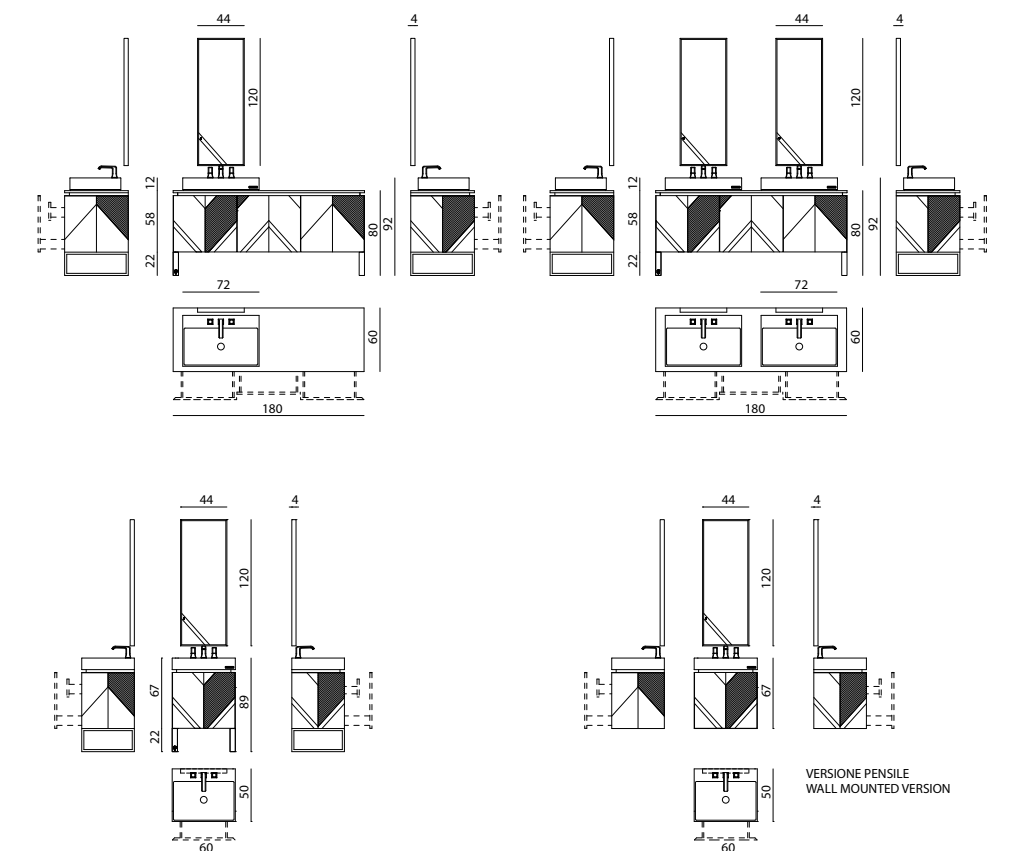



WINDSOR

CONSOLLE PORTA LAVABO

WASH-BASIN CONSOLE

Alessandro La Spada

Consolle porta lavabo con 8 cassetti (6 "segreti" con apertura push-pull e 2 con maniglia a scudo in ottone massiccio). Struttura mista in legno massiccio tu li piè e MDF laccato lucido 100 gloss, con decori a rilievo. Decorazioni metalliche in ottone cromato, bracciali decorativi sui piedi in alluminio e acciaio laserato cromato. Guide cassetti bilanciate con rientro smorzato nei cassetti con maniglia. Lavabo in ceramica sagomata con piattello copri scarico, finitura smalto bianco con logo dorato o platinato. Rubinetto classico in ottone cromato, predisposto per installazione su top. Le parti in metallo sono disponibili nella selezione finiture metalliche.

Console washbasin with 8 drawers (6 "hidden" drawers with push-pull opening and 2 with solid brass shield handles). Structure made of solid tulipè wood and MDF shiny lacquered 100 gloss, with decorations in relief. Chromed brass metal decorations, decorative rings on the feet in aluminium and laser cut chrome steel. Drawer's rail balanced through a dampened return system. Shaped ceramic basin with drain cover, white enamel finish with platinum or gold logo. Classic chromed brass tap, suitable for installation on top. Metal components can be finished with any lacquer of the metal lacquer finish selection.

vedi anche/see also WINDSOR tavolo da pranzo-dining table, WINDSOR mobile trucco-make-up unit, WINDSOR cassetiera-chest of drawers for desk, WINDSOR scrittoio con cassetti-desk with drawers, WINDSOR vetrinetta-showcase, WINDSOR parete modulare-modular elements, WINDSOR armadio-wardrobe, WINDSOR specchiera-mirror, WINDSOR vaso-vase

● [click here](#)

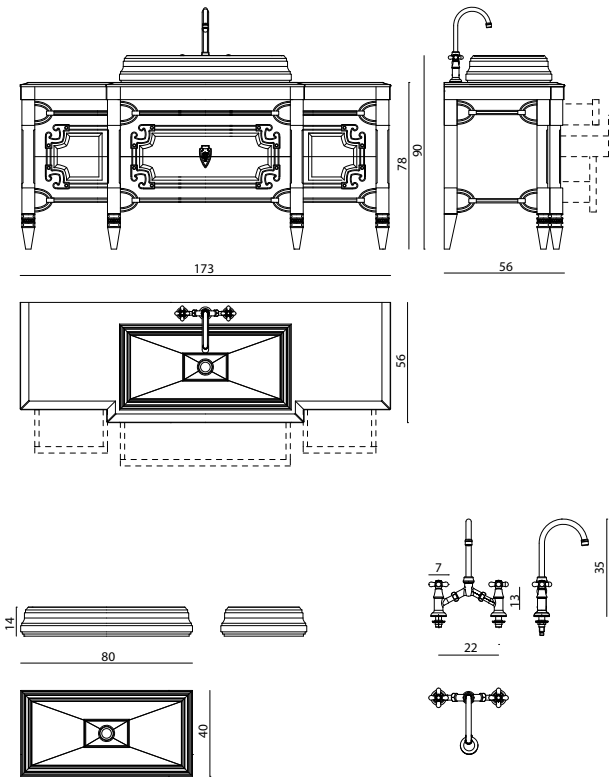

- click on the icons -



DAHLIA p.496



MAYFAIR p.500



VICTORIAN p.502



VILLA D'ESTE p.507



DAHLIA

BLOCCO CUCINA - KITCHEN BLOCK

COMPOSIZIONE LINEARE - COMPOSITION LINEAR

Alessandro La Spada - Samuele Mazza

Struttura principale in listellare rivestita esternamente ed internamente in laminato alluminio satinato. Schienali per le basi del blocco principale realizzati in compensato multistrati da mm 22, sagomato e laccato. Gambe tornite in alluminio cromato finitura lucida. Top in granito "Black Cosmic". Ante in MDF sp. mm 20 laccate lucide. Cassetti di serie con sponde carenate in acciaio e alluminio ad estrazione totale, portata kg 50. Fondo in multistrati placcato laminato alluminio satinato. Zoccolo rivestito in acciaio lucido.

Main structure in block wood externally and internally laminated with satin aluminium. Back for the bases of the principal block are made in plywood 22 mm, curved and lacquered. Turned legs in chromed polished aluminium. Top in granite "Black Cosmic". Doors in plywood 20 mm polished lacquered. Standard drawers with sides covered in steel and aluminium, total extraction, support 50 kg. Bottom in plywood laminated with satin aluminium. Base cornice covered in polished steel.

ELEMENTI DEL BLOCCO DAHLIA - DAHLIA BLOCK ELEMENTS

Schema di posizionamento delle basi.

Cabinet placement scheme.

BASI - BLOCK CABINET

Base "A" L. 60 P. 60 h. 87 cm: Pannelli bisellati-laccati. 2 cassetti h. 36 cm: un pannello intero con maniglia / un pannello diviso in due parti con 1 maniglia.

Base "B" L. 60 P. 60 h. 87 cm: Pannelli per cassetti bisellati-laccati: 2 cassetti h. 18 cm / 1 cassetto cm 36 / 3 maniglie.

Base "C" L. 60 P. 72 h. 87 cm: Predisposizione per lavastoviglie centrale. Pannello bisellato laccato: 1 maniglia.

Base "D" L. 90 P. 60 h. 87 cm: Utilizzabile per inserimento piano cottura. Base per piano cottura: 2 cassetti h. 36 cm / 1 pannello intero con 1 maniglia / 1 pannello diviso in due parti con 1 maniglia.

Base "E" L. 90 P. 60 h. 87 cm: Utilizzabile per inserimento lavello. 2 cassetti h. 36 cm / 1 pannello diviso in due parti con 1 maniglia / 1 pannello intero con 1 maniglia; cassetto inferiore con 3 contenitori inox per raccolta differenziata.

Base "A" L. 60 P. 60 h. 87 cm: Wooden lacquered bevelled panels. 2 drawers h. 36 cm: 1 panel with 1 handle / 1 panel divided in 2 parts with 1 handle.

Base "B" L. 60 P. 60 h. 87 cm: Wooden lacquered bevelled panels: 2 drawers h. 18 cm with 2 handles / 1 drawer cm 36 with 1 handle.

Base "C" L. 60 P. 72 h. 87 cm: Equipped for central dishwasher. Wooden lacquered bevelled panel: 1 handle.

Base "D" L. 90 P. 60 h. 87 cm: Ready for cook top placement. Base for cook top: 2 drawers h. 36 cm / 1 panel with 1 handle / 1 panel divided in 2 parts with 1 handle.

Base "E" L. 90 P. 60 h. 87 cm: Ready for sink placement. 2 drawer h. 36 cm / 1 panel divided in 2 parts with 1 handle / 1 panel with 1 handle; lower drawer equipped with 3 waste bins for separate collection. Ready for sink placement.

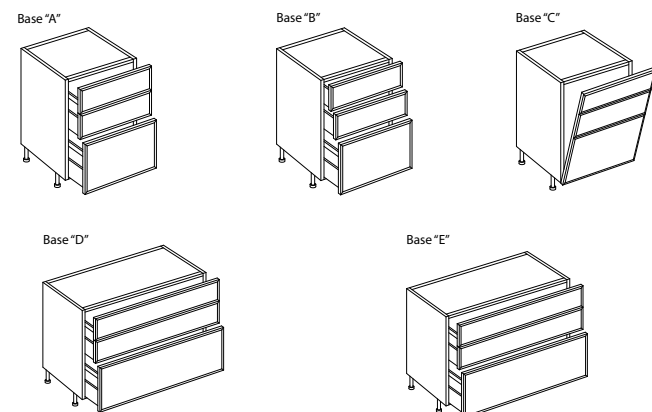
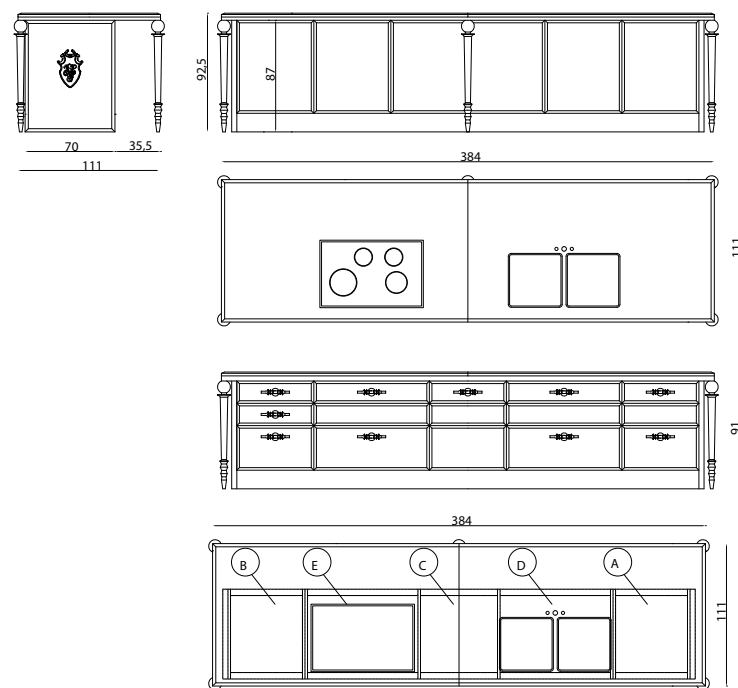

TOP - TOPS

Piano in granito Black Cosmic spessore mm 30. Diviso in due parti con bordo lavorazione bisello. Dimensione totale cm 111x384. Completo di fori per lavello e piano cottura.

Top in granite Black Cosmic thickness mm 30. Divided in 2 parts with bevelled border. Total dim. cm 111x384. Equipped with holes for sink and cook top.

Piano di sostegno in multistrati spessore mm 28 con bordo perimetrale in acciaio. Piastre di sostegno in metallo per fissaggio 5 gambe. Dimensione totale cm 110x383.

Supporting undertop thickness mm 28 with peripheral border in steel. Metal plates for n. 5 legs fixing. Total dimension cm 110x383.

GLI ZOCCOLI - THE BASE CORNICES

Kit zoccoli finitura inox.

Base mouldings kit - inox steel finish.

LAVELLO / MISCELATORE - SINK / SINGLE MIXER

Lavello in acciaio inox cm 40x40 h. 20. Miscelatore monocomando professionale con doccetta ad estrazione.

Stainless steel sink cm 40x40 h. 20. Professional single lever mixer with extractable rinsing spray.

PIANI COTTURA - COOK TOP

Piano cottura a induzione da incasso in vetroceramica.

Ceramic glass induction cooker hob - built in.

SCHIENALI PER BASI - BACK PANELS

Pannelli di finitura in legno laccato lucido lavorazione dei bordi a bisello.

Panels in shiny lacquered wood with peripheral bevelled borders.

PANNELLI - PANELS

Pannelli di chiusura per fianchi in legno laccato lucido e con lavorazione a bisello. Dimensioni L. 70 H. 87 cm, spessore 4 cm. Provvisto di inserti in lamina acciaio inox stemma araldico Visionnaire.

Side terminal panels in bevelled lacquered wood. Dimension L. 70 H. 87 cm, thickness 4 cm. Inclusive of Visionnaire coat of arms in laser cut steel foil.

KIT GAMBE - TURNING LEGS KIT

Kit gambe (x5) tornite.

Turning legs (x5) kit.

[click here](#)

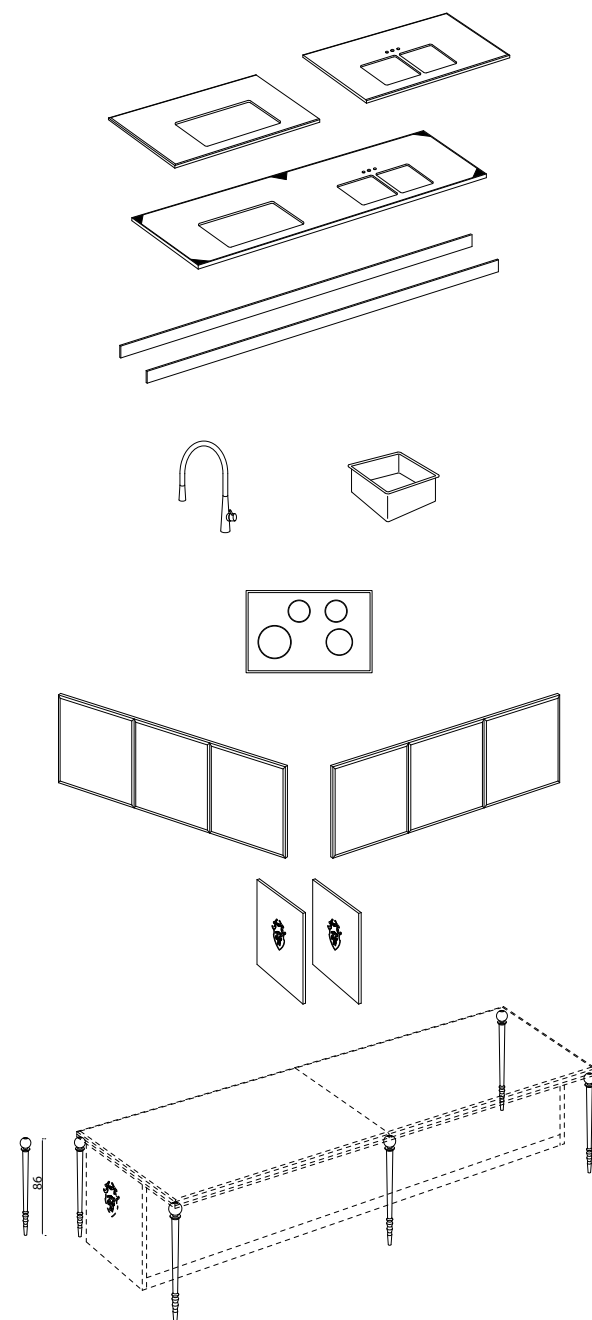



DAHLIA

CREDENZA - CUPBOARD

Alessandro La Spada - Samuele Mazza

Struttura portante in listellare rivestita esternamente ed internamente in laminato alluminio satinato. Fondo in multistrati placcato laminato alluminio satinato. Fondo e frontali cassetti in MDF spessore mm 20 laccato lucido con bordi a bisello. Cassetti di serie con sponde carenate in acciaio e alluminio ad estrazione totale, portata kg 50. Alzata centrale con rivestimento in vetro specchio con lavorazione a bisello. Completa di n. 2 ripiani. Pre-disposizione per inserimento elettrodomestici. Gambe tornite in alluminio cromato finitura lucida. Top in granito "Black Cosmic" con lavorazione del bordo a bisello. Zoccolo rivestito in acciaio lucido.

Main structure in block wood externally and internally laminated with satin aluminium. Back pieces in plywood laminated with satin aluminium. Door and drawer panels in MDF, 20 mm thickness, shiny lacquered, with bevelled borders. Standard drawers with sides covered in steel and aluminium, total extraction, support 50 kg. Central stand with mirror glass covering, bevelled edges. Equipped with 2 shelves. Equipped for home appliances. Turned legs in chromed polished aluminium. Top in granite "Black Cosmic" with bevelled borders. Base cornice covered in polished steel.

LO SPECCHIO CENTRALE

THE CENTRAL MIRROR

Specchio centrale Dimensione L. 180 H. 123,5 - Fasce perimetrali L. cm 14. Parte centrale divisa in tre parti (Centrale da cm 60 e 2 laterali da cm 46). Specchio bisellato. Provisto di 2 mensole cm 152x235 spess. cm 3,5 in legno laccato sul bordo con specchi bisellati (sopra e sotto).

Central mirror Dimension L. 180 H. 123,5 - Peripheral belts L. cm 14 Central part split in 3 (middle one L. cm 60 side parts L. cm 46.) Bevelled mirror. Equipped with 2 shelves dim. cm 152x23,5 thickness cm 3,5 in lacquered wood (for borders) and with lower and upper mirrors.

TOP CREDENZA - CUPBOARD TOP

Top credenza in granito Black Cosmic cm 180x70 spessore cm 3 con lavorazione bisello sul fronte. Pannello di supporto in listellare spessore mm 20 con profilato in laminato satinato.

Cupboard top in granite Black Cosmic cm 180x70 thickness cm 3 with bevelled front border. Supporting panel in block wood thickness mm. 20 laminated with satin aluminium.

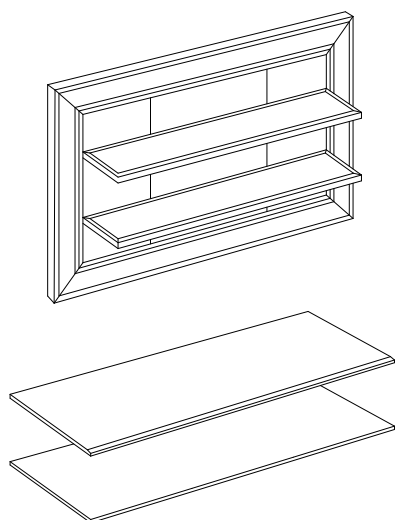
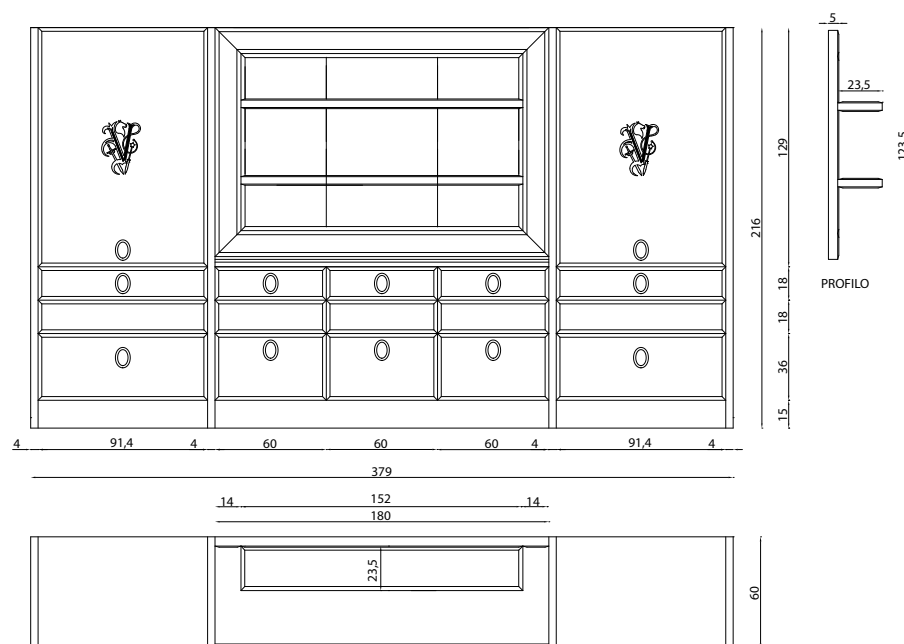

LE COLONNE - THE COLUMNS UNIT

CDC: Colonna dispensa L. 86 P. 60,5 h. 216 cm. predisposta per inserimento elettrodomestici 1 vano superiore cm 82x49 h 19 / 1 vano inferiore cm 82x49 h. 32,5 / 1 vano laterale cm 21,5x49 h. 140 / completo di n. 3 mensole in vetro.

FAC: Fianco colonna L. 65 h. 216 cm. con lavorazione a bisello spessore cm 4 laccato lucido. Anta rientrante con stemma araldico Visionnaire. 3 maniglie.

BSF: Base per credenza L. 60 P. 61 h. 87 cm. Pannelli bisellati-laccati: 2 cassetti h.36 cm: un pannello intero con maniglia / un pannello diviso in due parti con 1 maniglia.

CFC: Colonna frigorifero L. 91,5 P. 65 h. 216 cm. comprensiva di pannello terminale in legno laccato con lavorazione del bordo a bisello. Modello installato. FRIGO-200 Sub-zero 736TCI/RH 2715047. Combi: frigo/freezer (1 anta + 2 cassetti).

AFC: Anta e frontali cassetti mod. FRIGO-200 Sub-zero 736TCI/RH 2715047- Combi: frigo/freezer (1 anta+2 cassetti) 3 maniglie.

PIC: Pannello intermedio L. 65 h. 216 cm. Legno laccato spessore cm 4.

CDC: Cupboard column cm 86x60,5 h. 216 equipped for home appliances 1 upper space cm 82x49 h. 19 / 1 lower space cm 82x49 h. 32,5 / 1 side space cm 21,5x49 h.140 / with 3 glass shelves.

FAC: Column side cm 65x216 with bevelled border thickness cm 4 - shiny lacquered Roll away door with Visionnaire coat of arms. 3 handles.

BSF: Cupboard el installed FRIGO-200 Sub-zero 736TCI/RH 2715047. Combi: refrigerator/freezer (1 door+2 drawers).

AFC: Door and drawer panels for mod. FRIGO-200 Sub-zero 736TCI/RH 2715047- Combi: refrigerator/freezer (1 door + 2 drawers) 3 handles.

PIC: Side panels in lacquered wood thickness cm.4.

MANIGLIE - HANDLES

Maniglia A: Maniglia in alluminio tornito e cromato. Maniglia B "bamboo": Maniglia in alluminio tornito e cromato. Maniglia C "oval": Maniglia in alluminio cromato.

Maniglia A: Handle in turned and chromed aluminium. Maniglia B "BAMBOO": Handle in turned and chromed aluminium. Maniglia C "Oval": Handle in chromed aluminium.

click here

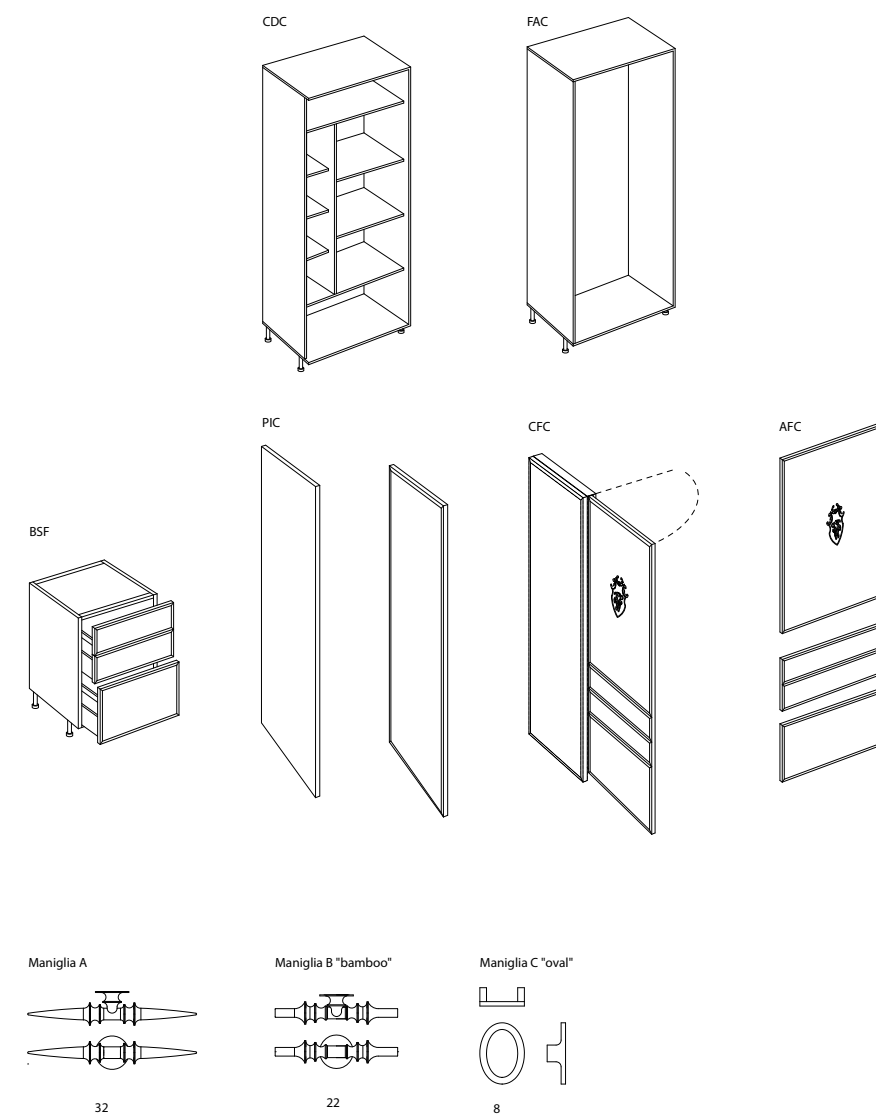



MAYFAIR

ISOLA CON SNACK DESK
ISLAND AND EXTENSION

Alessandro La Spada

Isola con snack desk. Struttura in particelle di legno nobilitate in melamminico ad alta resistenza sp. 19 mm con schienali nello stesso materiale sp. 10 mm, colore avorio. Ripiani interni in vetro di sicurezza satinato sp. 10 mm. Profili orizzontali di finitura in acciaio inox satinato. Basi con cestoni da 120 cm, cestoni superiori con maniglia e inferiori push-pull servoassistita, cassetti con fondo in particelle di legno nobilitate in melamminico ad alta resistenza sp. 16 mm colore grigio metallizzato e sponde laterali in acciaio verniciato e vetro. Guide cassetti ad estrazione totale con chiusura rallentata, portata 80 kg. Fianchi e schienali a vista in pietra naturale lavorata con decoro in bassorilievo e inserto decorativo in acciaio inox satinato, bordo di 25 mm in acciaio inox satinato sp. 2 mm. Zoccolo in multistrati marino da 65 mm rivestito in acciaio inox satinato. Accessori inclusi: illuminazione a LED, cappa aspirante a scomparsa nel top, portaposate, raccolta differenziata, portacoltelli, rubinetto in acciaio inox satinato con bocca orientabile, lavello in acciaio inox montato sottotop. Top in marmo Noir Saint Laurent lucidato con bordo da 10 cm con costa applicata. Predisposizione per fornelli indipendenti a induzione. Le decorazioni metalliche sono disponibili nelle finiture cromo, oro, champagne, bronzo, siena, nickel nero, canna di fucile.

Island composition with snack desk. Main structure in wood particles coated in high resistant melamine, 19 mm in width, with backrest in the same material, 10 mm in width, ivory colour. Internal shelves in satinized safety glass, 10 mm in width. Horizontal profiles finished in satinized stainless steel. Containing drawer base: 120 cm; upper drawer with handles and lower drawers with servo push-pull opening system. Drawers with bottom part in wood particles covered in high resistant melamine, 16 mm in width, colour metal grey and border in lacquered steel and glass. Runners of fully removable drawers with damped closing system, max capacity 80 kg. Sides and back in natural stone finished with decoration in bas-relief and decorative insert in satinized stainless steel, 25 mm profile in satinized stainless steel (width 2 mm). Plinth in 65 mm marine plywood coated in satinized stainless steel. Accessories included: LED lighting system, cooker hood hidden in the top, cutlery storage, waste collection system, knife block, faucet in satinized stainless steel with swivel spout, sink in stainless steel built in the undertop. Top in polished marble Noir Saint Laurent, 10 cm profile with thickening layer applied. Predisposition for induction independent cookers. Metal decoration available with metal selection finishings.

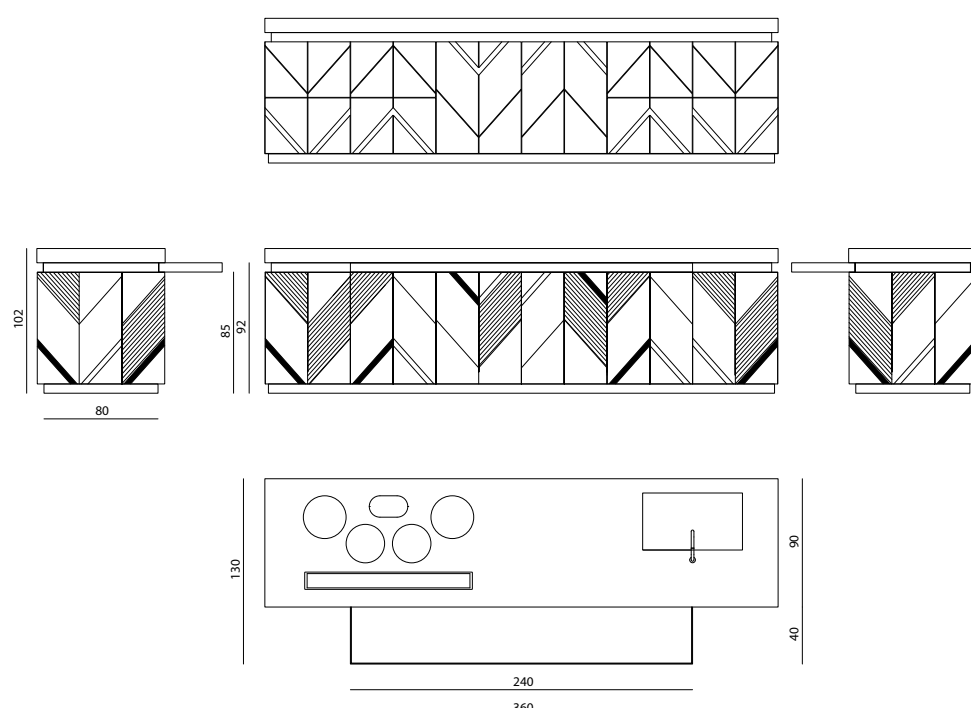

FINITURE - FINISHES

1. Grey Stone finitura lucida, decorazioni champagne satinato
2. Jolie Grey finitura lucida, decorazioni bronzo satinato.
3. Crema Marfil finitura lucida, decorazioni canna di fucile.
4. Bardiglio Imperiale finitura lucida, decorazioni Siena.
5. Bianco d'Oriente finitura patinata, decorazioni oro satinato.

1. Grey Stone polished finishing, satinized champagne decorations.
2. Jolie Grey polished finishing, satinized bronze decorations.
3. Crema Marfil polished finishing, gunmetal decorations.
4. Bardiglio Imperiale polished finishing, Siena decorations.
5. Bianco d'Oriente leather finishing, satinized gold decorations.



BLOCCO COLONNE - COLUMNS BLOCK

Parete a 6 colonne con struttura in particelle di legno nobilitate in melamminico ad alta resistenza sp. 19 mm con schienali nello stesso materiale sp. 10 mm colore avorio. Ripiani interni in vetro di sicurezza satinato sp. 10 mm. Profili verticali di finitura in acciaio inox satinato. Colonne dispensa dotate di ante a battente con cerniere ammortizzate, colonne forni dotate di ante rientranti. Illuminazione interna a LED. Ante in pietra naturale lavorata con decoro in bassorilievo e inserto decorativo in acciaio inox satinato, bordi di 25 mm in acciaio inox satinato sp. 2 mm. Fianchi di finitura in MDF laccato opaco. Zoccolo in multistrati marino da 65 mm rivestito in acciaio inox satinato. Le decorazioni metalliche sono disponibili nelle finiture cromo, oro, champagne, bronzo, Siena, nickel nero, canna di fucile. Composizione predisposta per il montaggio di accessori ed elettrodomestici: Frigorifero mastercool, macchina del caffè, cassetto porta tazzine, macchina per sottovuoto, forno a microonde, forno a vapore, forno multifunzione.

Modular element with 6 columns. Main structure in wood particles covered in high resistant melamine, 19 mm in width, with backrest in the same material, 10 mm in width, colour ivory. Internal shelves in satinized safety glass, 10 mm in width. Vertical profiles in satinized stainless steel. Storage unit equipped with swing doors with damped hinges. Units with ovens equipped with roll-away door. Internal LED light system. Doors in natural stone finished with decorations in bas-relief and insert in satinized stainless steel, 25 mm profiles in satinized stainless steel (width 2 mm), sides in MDF matt lacquered. Plinth in 65 mm marine plywood coated in satinized stainless steel. Metal decoration available in chrome, gold, champagne, bronze, Siena, black nickel and gunmetal finishing. This composition is predisposed for accessories and appliances: Mastercool fridge, coffee machine, cup holder drawer, vacuum machine, microwave oven, steam oven, multifunction oven.

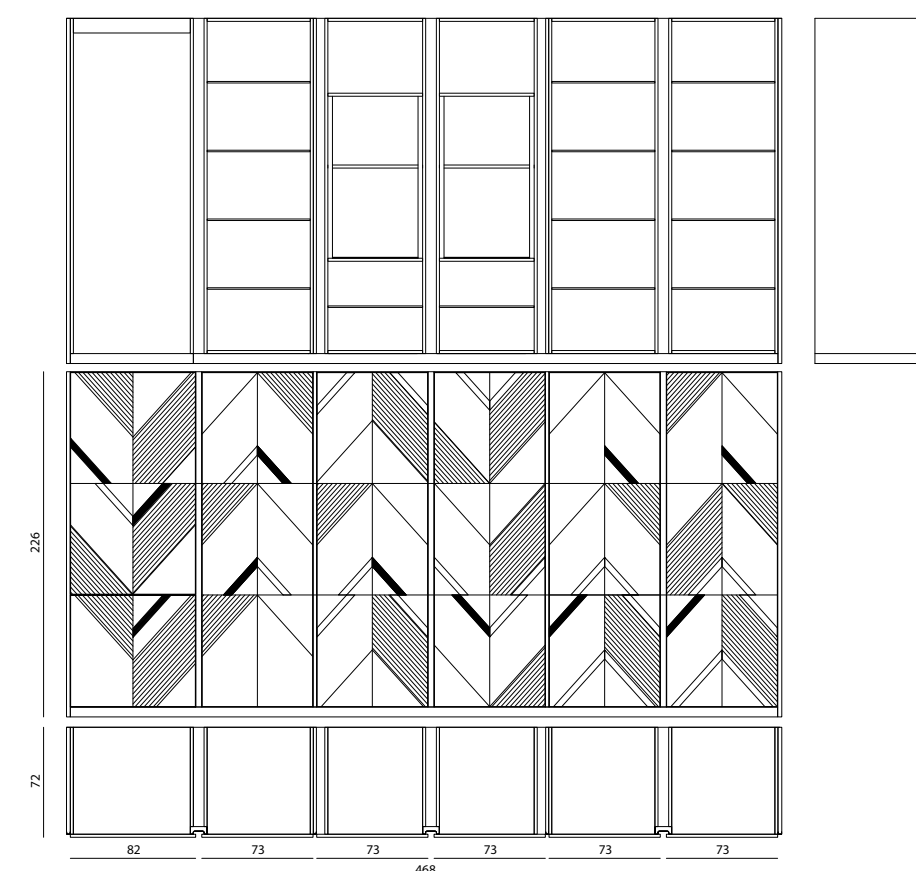



FINITURE - FINISHES

1. legno laccato lucido Ghiaccio RAL 7047 con fregi e borchie in ottone cromo.
2. legno laccato lucido RAL 9016 con fregi e borchie in ottone bronzo lucido.
3. legno laccato lucido Nero RAL 9005 con fregi e borchie in ottone anticato.
4. inox satinato laccato nichel nero con fregi e borchie in ottone anticato.
5. inox satinato laccato bronzo con fregi e borchie in ottone laccato bronzo lucido.
6. inox satinato naturale con fregi e borchie in ottone laccato nichel nero lucido.
7. legno laccato lucido RAL 1013 con fregi e borchie in ottone laccato oro satinato.
8. inox satinato laccato ottone lucido con fregi e borchie in ottone cromato

1. glossy lacquered wood Ghiaccio RAL 7047 with chromed brass decorations and studs.
2. glossy lacquered wood RAL 9016 with polished brass decorations and studs.
3. glossy lacquered wood Black RAL 9005 with antique brass decorations and studs.
4. satinized stainless steel black nickel lacquered with antique brass decorations and studs.
5. satinized stainless steel bronze lacquered with brass decorations and studs bronze lacquered.
6. satinized natural stainless steel with brass decorations and studs lacquered in shiny black nickel.
7. glossy lacquered wood RAL 1013 with brass decorations and studs lacquered in satinized gold.
8. satinized stainless steel shiny brass lacquered with chromed brass decorations and studs.

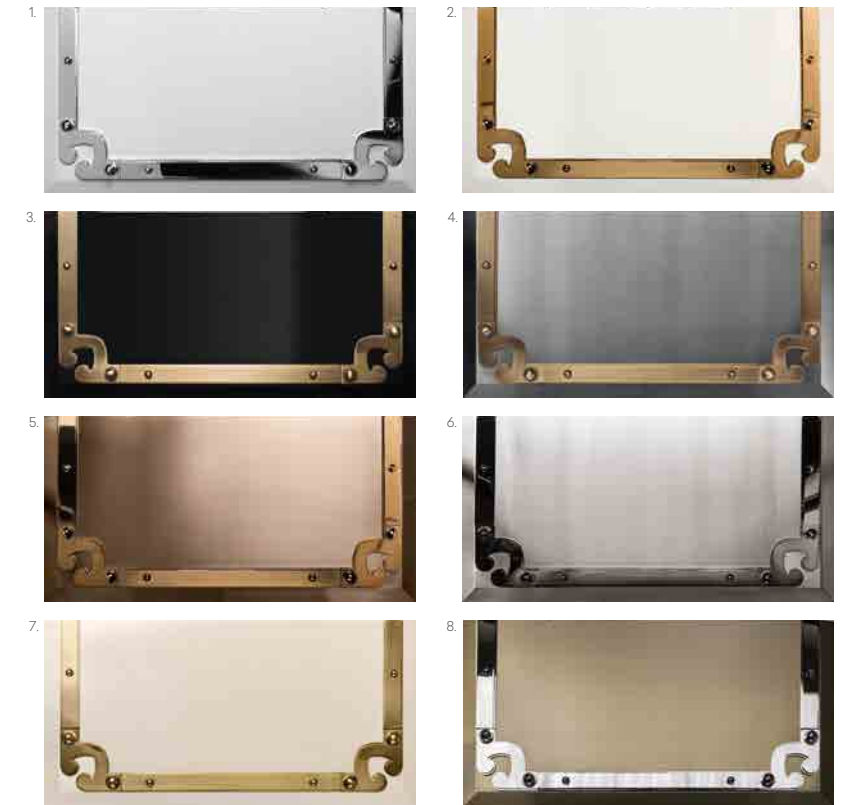

VICTORIAN

BLOCCO CUCINA - WORKING AREA COMPOSITION

Alessandro La Spada

Struttura in legno. Rivestimento ante e pannelli in acciaio inox spazzolato lacca nikel nero, con profili decorativi e borchie di fissaggio in ottone anticato.

Finiture alternative:

- inox satinato naturale con fregio e borchia in ottone anticato;
 - inox satinato lacca bronzo lucido con fregio e borchia in ottone anticato;
 - legno laccato lucido ral 9005 con fregio e borchia in ottone anticato;
 - legno laccato lucido perla "Ostrica" con fregio e borchia in ottone anticato;
 - legno laccato lucido ral 7047 con fregio e borchie in ottone cromo satinato.
- Maniglioni in ottone anticato. Pomelli del gas fresati personalizzati "Visionnaire" con finitura ottone e logo inciso, regolazione del gas elettronica. Angolari zoccolo ottone anticato. Ferramenta di complemento in ottone anticato.

Il Blocco cucina è allestito nella seguente configurazione:

- colonna laterale di sinistra con frigo e freezer;
- colonna laterale di destra: parte superiore: macchina caffè, scaldavivande e ripiani con illuminazione LED; parte inferiore: cestoni con scaldastoviglie; base di sinistra a cestoni con cassetti interni;
- base di destra con lavastoviglie;
- base centrale: lavello integrato al top in acciaio Aisi 304 con luce LED; rubinetto in acciaio e ottone personalizzato Visionnaire;
- elemento contenitore a cestoni. Vano di sinistra a cestone con cassetto interno portaposate in legno wengè massello. Vano di destra a cestoni con contenitori personalizzabili per la raccolta differenziata.

Barra sottopensile attrezzata con ganci e mensole per mestoli.

Structure in wood. Doors and panels covered of brushed stainless steel black nickel lacquered, with decorative outlines and fixing studs in antique brass.

Alternative finishes:

- satin stainless steel natural and frieze with antique brass stud;
 - steel with satin lacquer polished bronze frieze and antiqued brass stud;
 - RAL 9005 lacquered wood with decorative studs and antique brass;
 - pearl "Ostrica" lacquered wood with decorative studs and antique brass;
 - RAL 7047 lacquered wood with decorative studs and satin chrome brass.
- Handles in antique brass. Hob knobs in milled antique brass with logo engraved. Milled hob knob personalized "Visionnaire" with brass finishing and logo engraved, electronic gas regulation. Complementary metalware in antique brass.

The working area composition is set in the following configuration:

- left column with fridge and freezer;
- right column is divided in upper part and lower part. The first one is composed of coffee machine, chafing dish and shelves with LED lightings and the other is composed of hamper-drawers; left base with internal hamper-drawers; right base with dishwasher;
- central base: Sink integrated to the top in stainless steel Aisi 304 with LED spot. Tap in steel and brass personalized "Visionnaire";
- container element with big drawers: in the left part there is an internal flatware organizer compartment in solid wengè wood while in the right compartments there are hampers for recycle bins.

Shelves with hanging tubes for dashers and kitchen tools, in antique brass.

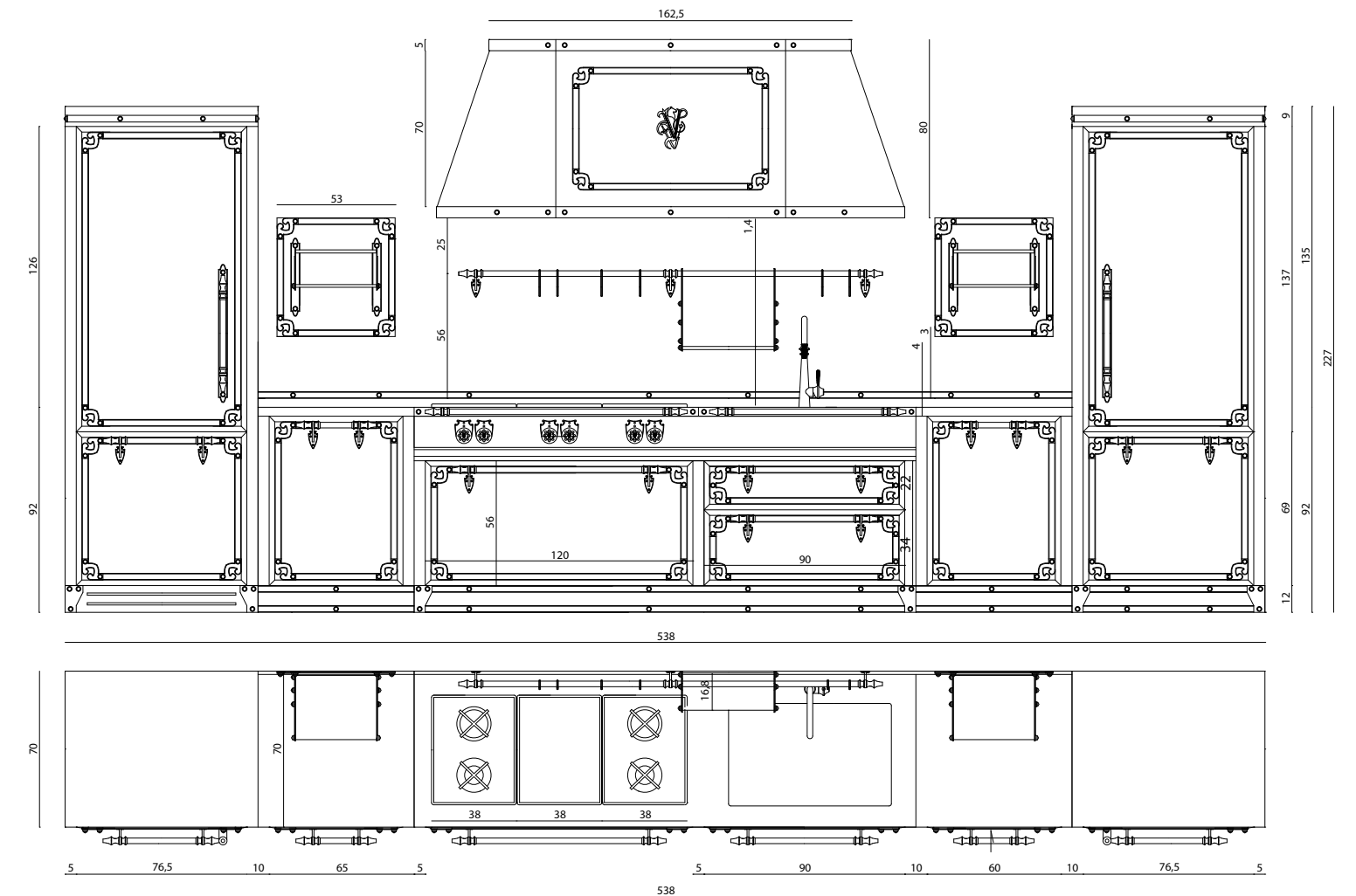

● [click here](#)



VICTORIAN

CAPPA ASPIRANTE - RANGE HOOD

Alessandro La Spada

Struttura in acciaio satinato curvato con profili in ottone anticato e logo in ottone inciso anticato. Motore aspirante e illuminazione a faretto incassati. Ante e pannelli disponibili anche in finitura: acciaio spazzolato naturale, lacca bronzo, o in legno laccato lucido. Fregi e borchie disponibili anche in cromo satinato.

Structure in curved satinized stainless steel with antique brass outlines and Visionnaire logo engraved. Lighting with recessed spotlights. Doors and panels also available in natural or bronze lacquered brushed stainless steel. Decorative outlines and studs also available in satin chrome.

● [click here](#)

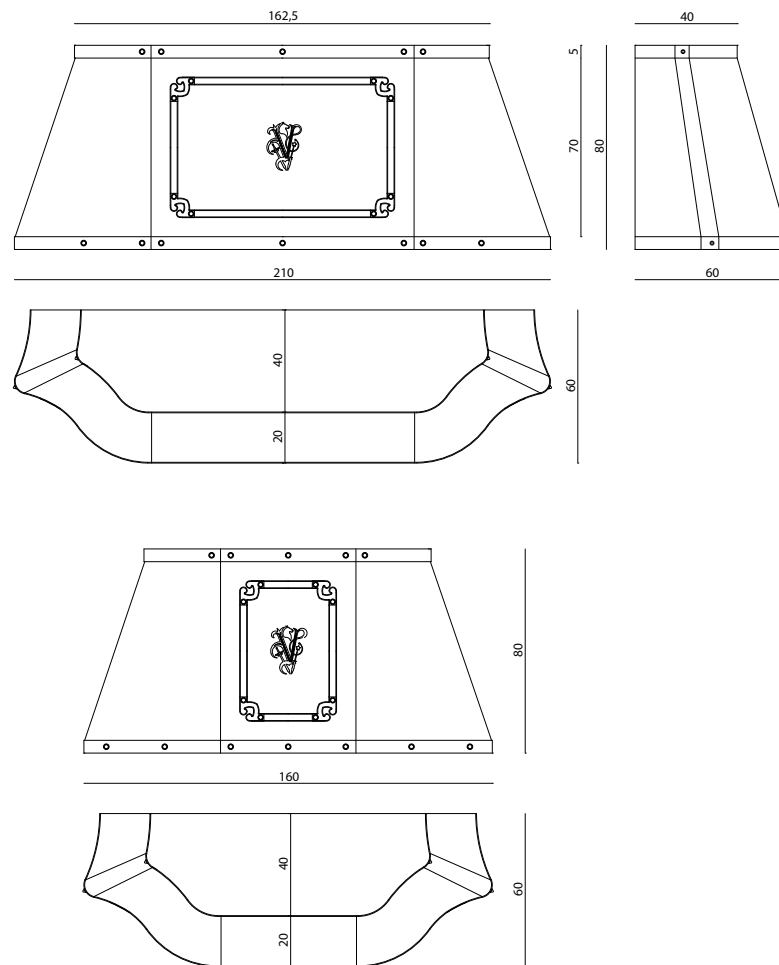

VICTORIAN

BLOCCO ISOLA - ISLAND COMPOSITION

Alessandro La Spada

Struttura in legno. Rivestimento ante e pannelli in acciaio inox spazzolato lacca nikel nero, con profili decorativi e borchie di fissaggio in ottone anticato. Finiture alternative:

- inox satinato naturale con fregio e borchia in ottone anticato;
- inox satinato lacca bronzo lucido con fregio e borchia in ottone anticato;
- legno laccato lucido ral 9005 con fregio e borchia in ottone anticato;
- legno laccato lucido perla "Ostrica" con fregio e borchia in ottone anticato;
- legno laccato lucido ral 7047 con fregio e borchie in ottone cromo satinato.

Maniglioni in ottone anticato. Angolari zoccolo ottone anticato. Ferramenta di complemento in ottone anticato. Top in quercia massiccia listellare spessore 10 cm con loghi incassati ottone inciso anticato. Gambe con tornerie in alluminio cromato lacca ottone con bocce in ottone ed elemento centrale in legno sfaccettato. Tagliere in granito "earth glitter" sagomato e bisellato. Base composta da 4 cestoni con illuminazione LED.

Structure in wood. Doors and panels covered of brushed stainless steel black nickel lacquered, with decorative outlines and fixing studs in antique brass. Alternative finishes:

- satin stainless steel natural and frieze with antique brass stud;
- steel with satin lacquer polished bronze frieze and antiqued brass stud;
- RAL 9005 lacquered wood with decorative studs and antique brass;
- pearl "Ostrica" lacquered wood with decorative studs and antique brass;
- RAL 7047 lacquered wood with decorative studs and satin chrome brass.

Handles in antique brass. Plinth corners in antique brass. Complementary metalware in antique brass. Top in solid oak wood th. 10 cm with logos engraved in antique brass, legs with chromed aluminium turnings, brass lacquered with spheres in brass and central element in multifaceted wood. Cutting board in "earth glitter" granite, contured and beveled. Base composed of 4 hamper-drawers with LED lightings.

● [click here](#)

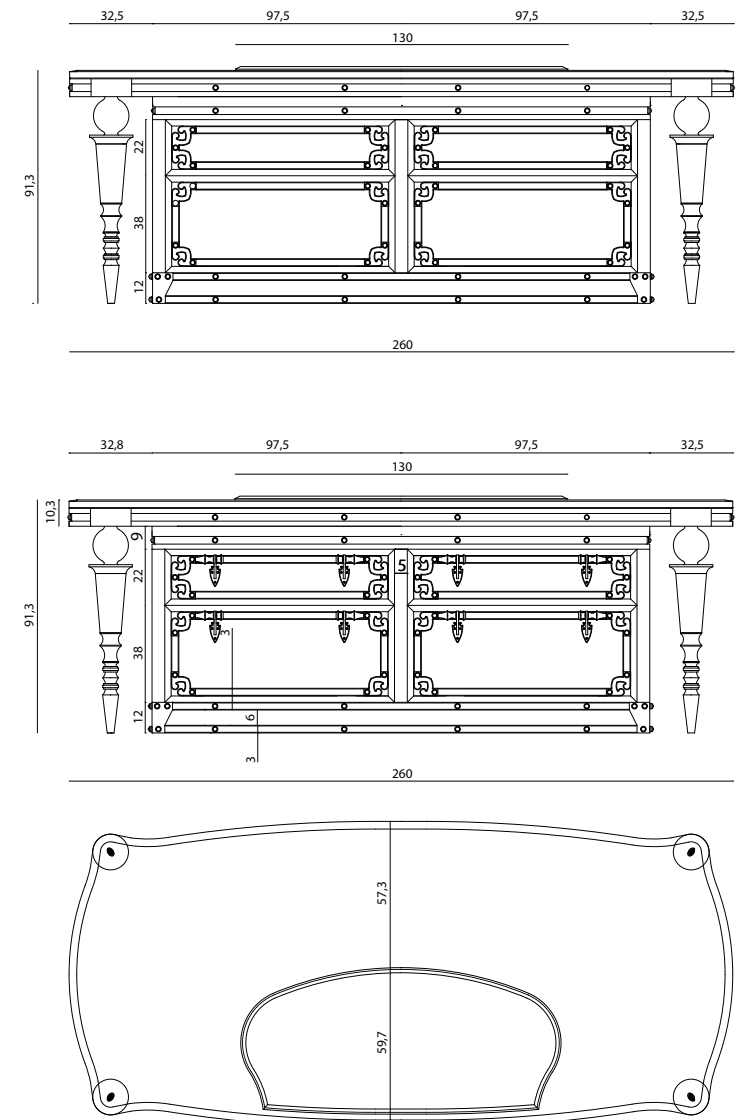



VICTORIAN

BLOCCO CANTINA - WINE CABINET UNIT

Alessandro La Spada

Struttura in legno. Rivestimento ante e pannelli in acciaio inox spazzolato lacca nikel nero, con profili decorativi e borchie di fissaggio in ottone anticato.

- Finiture alternative:
- inox satinato naturale con fregio e borchia in ottone anticato;
 - inox satinato lacca bronzo lucido con fregio e borchia in ottone anticato;
 - legno laccato lucido ral 9005 con fregio e borchia in ottone anticato;
 - legno laccato lucido perla "Ostrica" con fregio e borchia in ottone anticato;
 - legno laccato lucido ral 7047 con fregio e borchie in ottone cromo satinato.

Maniglia in ottone anticato. Angolari zoccolo ottone anticato. Ferramenta di complemento in ottone anticato. Anta cantinetta in vetro.

Il Blocco cantina è allestito nella seguente configurazione:

- colonne laterali con ripiani in vetro, illuminazione interna a LED e cestoni;
- colonna centrale, cantinetta a controllo termico a tre zone per vini, con portabottiglie scorrevoli in faggio.

Structure in wood. Doors and panels covered of brushed stainless steel black nickel lacquered, with decorative outlines and fixing studs in antique brass.

- Alternative finishes:
- satin stainless steel natural and frieze with antique brass stud;
 - steel with satin lacquer polished bronze frieze and antiqued brass stud;
 - RAL 9005 lacquered wood with decorative studs and antique brass;
 - pearl "Ostrica" lacquered wood with decorative studs and antique brass;
 - RAL 7047 lacquered wood with decorative studs and satin chrome brass.

Handles in antique brass. Plinth corners in antique brass. Complementary metalware in antique brass. Wine unit door in glass.

- Wine cellar cupboard is composed as following:
- side columns with shelves in glass, internal LED lightings and hamper-drawers;
 - central column set with cellar for wines with different temperature control in the three zones and sliding bottle carrier in beech wood.

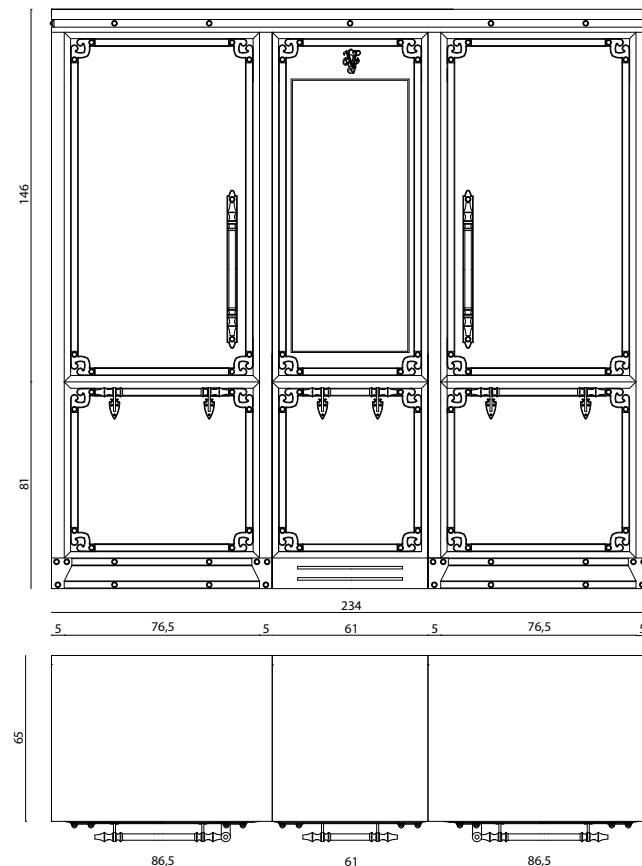

● click here

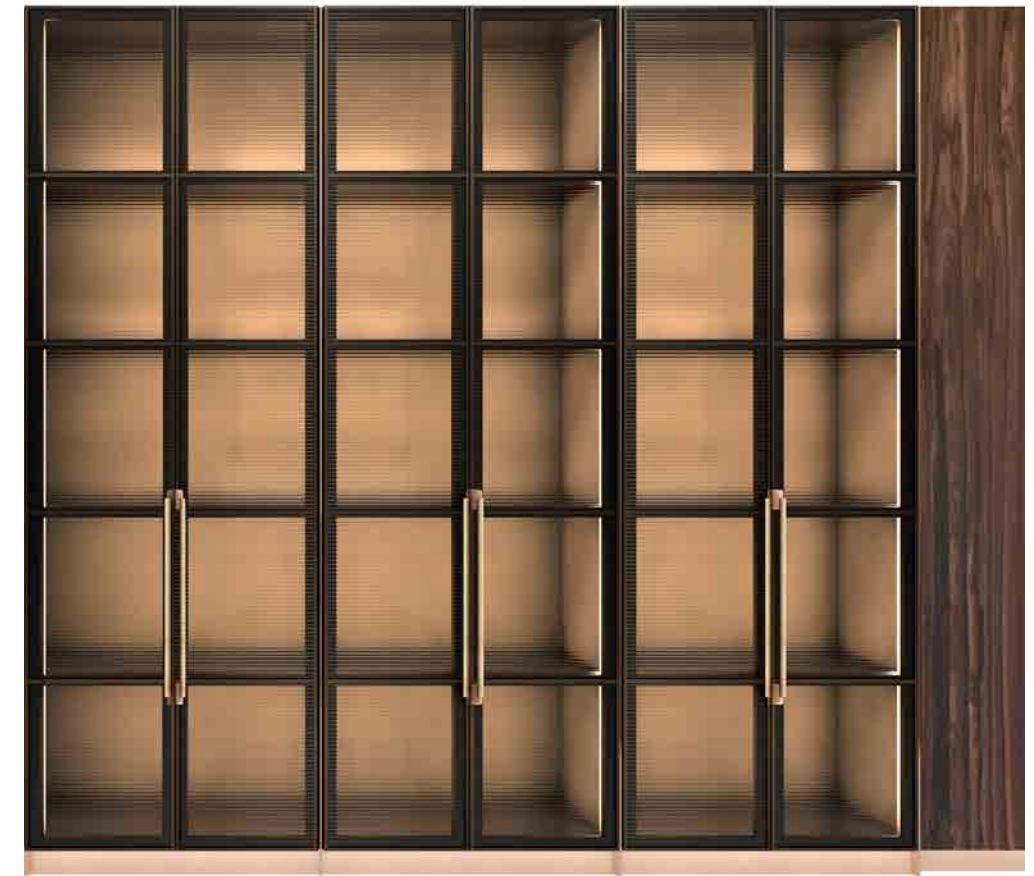

VILLA D'ESTE

VETRINETTA - SHOWCASE

Mauro Lipparini

Vetrinetta con mobili in legno rivestiti internamente in pelle o tessuto, con ante in alluminio e vetro rigato orizzontale. Le ante e le mensole interne hanno un telaio in alluminio trafilato verniciato a polveri e pannelli in vetro. Zoccoli, profili e dettagli in acciaio satinato disponibili nella selezione finiture metalliche. Vani interni illuminati a LED.

Showcase with wooden furniture covered internally with leather or fabric, with aluminium doors and horizontal ribbed glass. The doors and internal shelves have a drawn, powder-coated aluminium frame and glass panels. Satin-finish steel plinths, profiles and details available in the metal finish selection. LED-illuminated interior compartments.

● click here

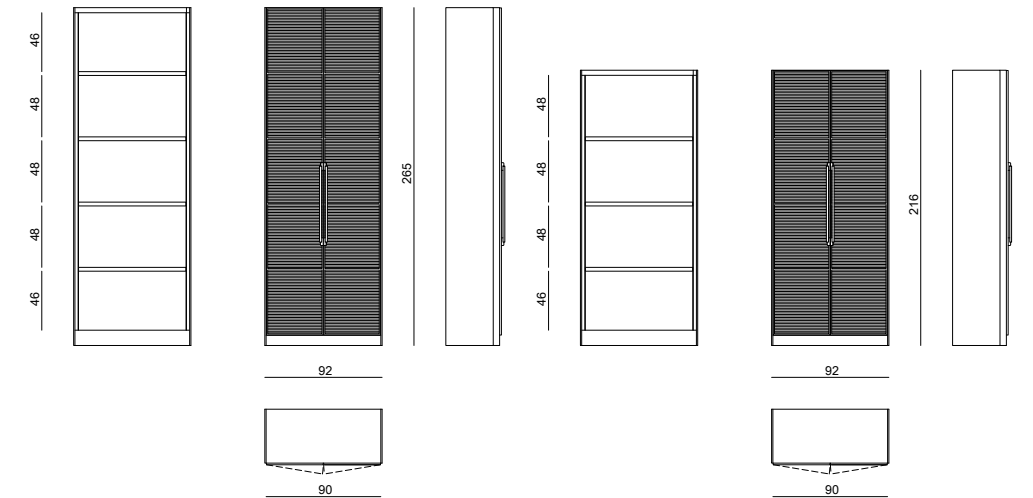



VILLA D'ESTE

BLOCCO CUCINA - KITCHEN BLOCK

Mauro Lipparini

Cucina in marmo e legno. Moduli a parete: colonne attrezzate con ripiani o predisposte per elettrodomestici da refrigerazione o cottura (frigoriferi, congelatori, forni, abbattitori, macchine per il caffè, ecc.), apertura ante push-pull disponibili con apertura servo-assistita, ante frigo a trascinamento, ante forno a scomparsa. Tra le colonne è possibile inserire moduli contenitore scorrevoli a estrazione totale con frontali lavorati in legno curvo e vetro rigato, retroilluminato. Le ante sono in legno impiallacciato con finitura opaca della selezione essenze.

Il top è in marmo sp. 30 mm predisposto per lavello a incasso sotto-top. Vani interni illuminati. Zoccoli, profili e dettagli in acciaio satinato disponibili nella selezione finiture metalliche. Isola centrale: blocco da centro stanza con ante rivestite in marmo sp. 25 mm con bordi sagomati, gli angoli dell'isola sono in marmo lavorati dal pieno con spigoli arrotondati con raggio di 10 cm, il top è scatolato con sezione inclinata e gola sotto-top retroilluminata (che funge da maniglia per le ante). I mobili sono realizzati in particelle di legno e multistrati rivestiti internamente in laminato antigraffio di alta qualità. Predisposta per accogliere elettrodomestici, contenitori, zona acqua, zona cottura e cappa a scomparsa. Cestoni disponibili con apertura servo-assistita. All'isola in marmo è abbinato uno snack desk a sbalzo con sotto-top in legno laccato e top in essenza opaca disponibile nella selezione essenze (disponibile anche lucida o in marmo). Vani interni illuminati a LED.

Marble and wood kitchen. Wall-mounted modules: tall units equipped with shelves or predisposed for refrigeration or cooking appliances (refrigerators, freezers, ovens, blast chillers, coffee machines, etc.), push-pull door openings available with servo-assisted opening, drag-and-drop refrigerator doors, concealed oven doors. Between the tall units it is possible to insert full-extension sliding storage modules with fronts in curved wood and ribbed, backlit glass. The doors are in veneered wood with a matt finish from the veneer selection.

The top is made of 30 mm thick marble arranged for a built-in under-top sink. Illuminated internal compartments. Plinths, profiles and details in satin-finish steel available in the metal finish selection. Central island: room centre block with doors covered in 25 mm thick marble with shaped edges, the corners of the island are made of solid marble with rounded edges with a radius of 10 cm, the top is boxed with an inclined section and backlit under-top groove (which acts as a handle for the doors). The cabinets are made of particle board and plywood covered with high quality scratch-resistant laminate on the inside. Predisposed for accommodating household appliances, storage units, water zone, cooking zone and concealed hood. Baskets available with servo-assisted opening. The marble island is combined with a cantilevered snack desk with lacquered wood under-top and matt wood top available in the wood selection (also available glossy or in marble). LED-illuminated internal compartments.

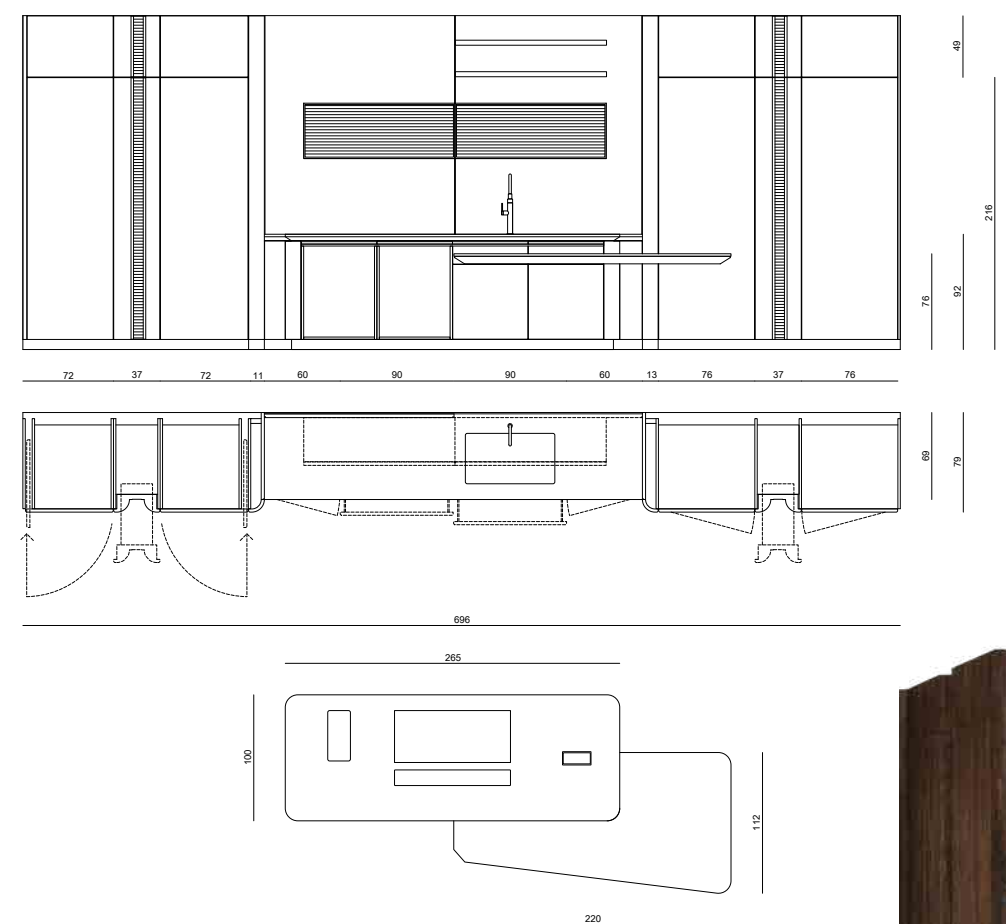

● [click here](#)

- click on the icons -

DIVANI E POLTRONE - SOFAS AND ARMCHAIRS



BASKET p.516



BOULEVARD p.517



BRAMANTE p.518



GREEN LIFE p.519



GALLOWAY p.520



GALLOWAY p.521



GALLOWAY p.521



ILARIO p.522



WING p.525



KATHRYN OUTDOOR p.526



KATHRYN OUTDOOR p.527



KATHRYN OUTDOOR p.527



PALM BEACH p.528



PALM BEACH p.529



PALM BEACH p.529



STANKAR p.530



STANKAR p.531



STANKAR p.531

- click on the icons -

LETTINI - DAYBEDS



AYDON p.532



EIROS p.533



FOIL p.533



FARNESE p.534



REDDING p.535



REDDING p.535



SIESTA p.536



SVEVA p.537

SEDIE E SGABELLI - CHAIRS AND STOOLS



ALBATROS DEHORS p.538



AMINTA DEHORS p.538



ASTRID DEHORS p.539



CLEM DEHORS p.539



CLEM DEHORS p.540



CONEY ISLAND p.540



ELEANOR DEHORS p.541



FARNESE p.541



FREDDIE p.542

- click on the icons -



KYLO PADDED DEHORS p.543



KYLO PADDED DEHORS p.543



PANAREA p.544



SUNNY DEHORS p.544



SUNNY DEHORS p.545



TANYA DEHORS p.545



VANJA p.546

TAVOLI DA PRANZO E TAVOLINI - DINING TABLES AND SMALL TABLES



BREEZE OUTDOOR p.548



CONEY ISLAND p.548



CYCAS p.549



DYLAN 2022 p.549



FARNESE p.550



GALLOWAY p.550



FREDDIE p.551



GORGONA p.552



MERLINO DEHORS p.552



OBERTO p.553



PALM BEACH p.554



REDDING p.554

- click on the icons -



PANAREA p.555



PERGAMO p.556



SOLSTICE p.557



STANKAR p.558



VIENNA p.558



WING p.559

ACCESSORI E ILLUMINAZIONE - ACCESSORIES AND LIGHTING



APPLE p.560



CALLIA DEHORS p.560



CALLIA p.561



KATHRYN OUTDOOR p.561



POLARIS p.562



PANAREA p.562



ERCOLANO p.563



POMPEI p.563

COLLEZIONE DEHORS

I mobili della collezione DEHORS VISIONNAIRE sono in generale adatti ad un uso in ambienti esterni non completamente esposti alle intemperie, posizionati in luoghi coperti, asciutti, areati e su pavimentazioni prive di umidità. Per i mobili imbottiti, i rivestimenti disponibili sono presenti nel Campionario Dehors. Le parti in metallo sono trattate per un utilizzo in ambienti esterni non completamente esposti alle intemperie, in caso di utilizzo su imbarcazioni o ambienti marini, l'ordine deve essere approvato dall'ufficio tecnico Visionnaire.

Alcuni prodotti costruiti in materiali particolarmente delicati quali rattan naturale, pelle, legno massello sono sconsigliati per un uso completamente esposto alle intemperie e richiedono cura e manutenzione particolari:

NORME GENERALI

- Posizionare gli articoli in ambiente protetto da copertura (es. tetto, gazebo, patio, ecc.);
- Non posizionare su terreno, erba o su qualsiasi altra superficie con alto tasso di umidità;
- Coprire con l'apposito telo impermeabile, in caso di pioggia e altre intemperie, accertandosi di mantenere comunque un'adeguata aerazione del prodotto;
- ATTENZIONE: non coprire i mobili con l'apposito telo impermeabile in caso di eccessiva umidità oppure dopo la pioggia, e comunque attendere una completa asciugatura del prodotto e del pavimento prima di applicare nuovamente il telo impermeabile.
- In previsione della stagione invernale o di un prolungato inutilizzo si raccomanda di ritirare i mobili in un luogo chiuso ed asciutto e/o coprire i mobili con l'apposito telo impermeabile.

Tutti gli articoli richiedono una pulizia periodica generica:

- su tutte le superfici, usare un panno umido al fine di asportare polveri o incrostazioni che nel lungo periodo possono corrodere le superfici metalliche, macchiare pelli e tessuti o creare alterazioni superficiali sugli articoli in legno/metallo;
- per le superfici imbottite si raccomanda di ravvivare i cuscini ed i rivestimenti (es. con battipanni o altri strumenti idonei).

TRATTAMENTO DEI MATERIALI

Per alcuni materiali, oltre alle norme generali, vanno seguite alcune precauzioni specifiche. Per questi vanno usati prodotti e trattamenti per la manutenzione ordinaria:

LEGNO

BOULEVARD – BRAMANTE - BREEZE – FARNESE - GALLOWAY – GREEN LIFE

Nella movimentazione e nella pulizia del prodotto, fare molta attenzione a non danneggiare la superficie del legno ed a non graffiare la pellicola lucida, poiché questa costituisce una protezione all'esposizione del prodotto nel lungo periodo e alla sua corretta manutenzione. Per una pulizia ordinaria: utilizzare un panno umido al fine di asportare polveri o incrostazioni che nel lungo periodo possono corrodere le superfici.

KATHRYN

Manutenzione delle parti in legno: ogni 6 mesi applicare OIL FOR DECKING generico seguendo le istruzioni per la posa.

CUOIO

Le componenti in cuoio per i modelli GREEN LIFE, BOULEVARD e GALLOWAY FREESTYLE richiedono uno specifico trattamento, da effettuarsi almeno ogni 6 mesi, passando un panno inumidito con olio naturale per trattamento pelli, seguendo le istruzioni allegata alla confezione del prodotto.

OUTDOOR COLLECTION

Furniture of DEHORS VISIONNAIRE collection are generally suitable for use in external locations not totally exposed to the weather, those shall be placed in covered, dry, airy areas, on flooring without humidity. For padded furniture, suitable upholsteries are available in Dehors sample book. Metal parts are treated for outdoor use in external locations not totally exposed to the weather, if those are to be used on vessels or marine environments, the order shall be approved by Visionnaire technical department.

Some products made in extremely delicate materials, such as natural wicker, leather, solid wood, are not suitable for outdoor use in locations totally exposed to weather and require a specific maintenance:

GENERAL INSTRUCTIONS

- Place the items in a location with a protective coverage (such as rooftop, gazebo, patio, and similar);
- Do not place on earth, grass or any other surface with high percentage of humidity;
- In case of rain or adverse weather conditions, cover furniture using the waterproof cover provided, making sure to enable adequate ventilation;
- ATTENTION: do not cover furniture with the waterproof cover provided in case of excessive humidity or after rain; always wait furniture and flooring are completely dry before using the waterproof cover.
- In view of forthcoming winter season or if leaving them unused for a long period of time, we recommend to store furniture in a closed and dry location and/or to cover them using the waterproof cover provided.

All furniture shall undergo regularly a thorough cleaning:

- On all surfaces, use a humid cloth to remove dust or scale residuals which may corrode leather surfaces over time, stain leather or fabric or cause superficial alterations of wood/metal surfaces;
- On padded furniture, we recommend to plump up cushions and restore upholstery (i.e. rug beater or similar suitable tools).

MATERIAL TREATMENT

Except above-mentioned general maintenance instructions, some materials require additional precautions to be used. In this case, specific products and treatments are to be used for their daily maintenance:

LEGNO

BOULEVARD – BRAMANTE - BREEZE – FARNESE - GALLOWAY – GREEN LIFE

When handling and cleaning these products, take care not to damage the wooden surface and not to scratch the shiny film over it, which works as protective cover from possible damages of prolonged exposition of the product and guarantees its correct maintenance. Daily maintenance instructions: use a humid cloth to remove dust and scale residuals which may corrode the surface over time.

KATHRYN

Maintenance of wooden parts: every 6 months apply generic OIL FOR DECKING following application instructions.

EMERY LEATHER

Components of GREEN LIFE, BOULEVARD and GALLOWAY upholstered in emery leather require a specific treatment, to be made every 6 months, rubbing on them a humid cloth with natural oil for leather treatment, following application instructions provided in the packaging.



BASKET

DIVANO, POLTRONA

SOFA, ARMCHAIR

m2atelier

Divano e poltrona, outdoor e indoor. Struttura portante in alluminio estruso con gambe in fusione di alluminio per esterni. Braccioli e sedile in massello di iroko sagomato. Fregi frontali dei braccioli in acciaio, disponibili nella selezione finiture metalliche lucide. Lo schienale è composto da una maglia di tasselli in iroko massello e cavi in acciaio. Imbottitura in poliuretano espanso a diverse densità e falda acrilica rivestiti con guaina idrorepellente e tessuti o pelli della selezione Dehors Collection. Cuscini volanti in fiocco acrilico. Le parti in metallo sono disponibili verniciate a polveri (per esterni) o nella selezione finiture metalliche satiniate. Le parti in legno massello sono protette con vernici isolanti per esterni con finitura opaca.

Sofa and armchair for indoor and outdoor use. Main structure in extruded aluminium with legs in aluminium cast finished with outdoor treatment. Armrests and seat in shaped iroko solid wood. Steel armrest front friezes, available in any lacquer of the polish metal finish selection. Backrest consisting of a mesh of tassels in iroko solid wood and steel wires. Padding in polyurethane foam with different densities and acrylic fiber, covered by a water-proof film and upholstered in fabric or leather from the Dehors collection of materials. Loose cushions in acrylic soft flake. Metal parts available with any of the powder coating in the outdoor metal finish selection or in any lacquer of the satin metal finish selection. Solid wood parts are finished with a mat isolating lacquer suitable for outdoor products.

● click here

archiproducts
DESIGN AWARDS
WINNER 2021

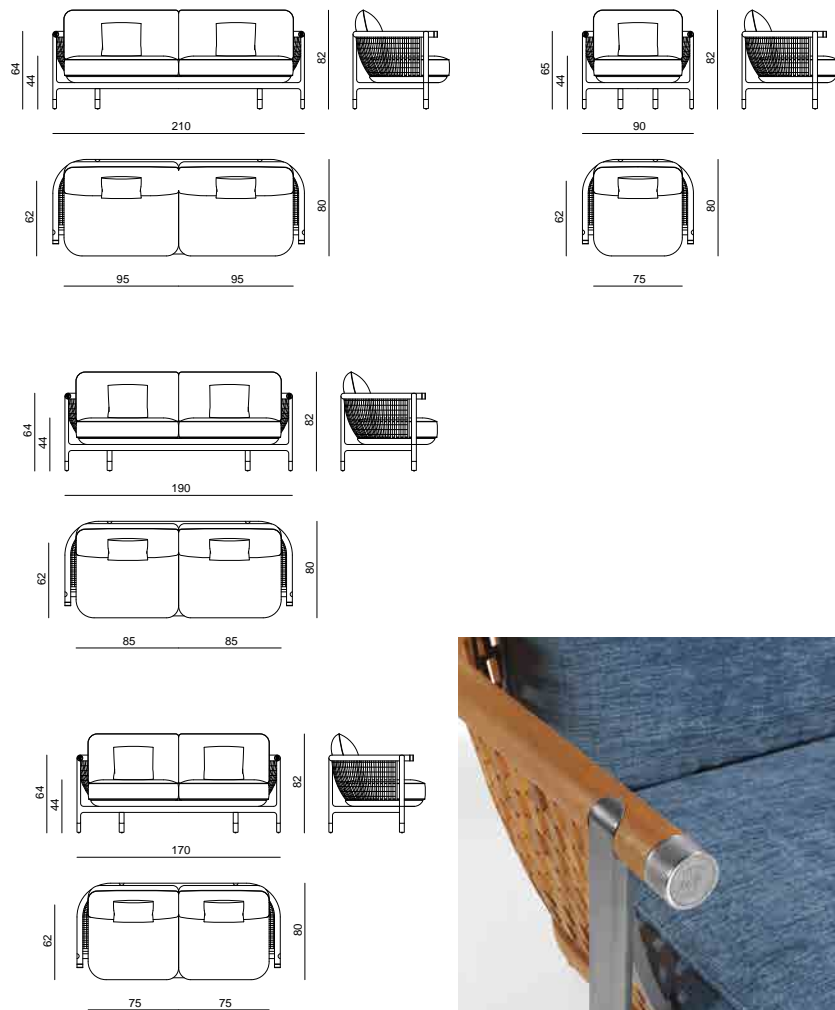

BOULEVARD OUTDOOR

DIVANO, POLTRONA - SOFA, ARMCHAIR

Roberto Tapinassi - Maurizio Manzoni

Struttura in massello di iroko assemblato con incastrati e colla poliuretanicca, punti metallici e zip in acciaio inox. Telaio di seduta in multistrati marino resistente all'acqua. Verniciatura poliuretanicca trasparente da esterno. Struttura di schienale e bracciolo in multistrati di betulla tamburato con compensato di pioppo e rivestito con cuoio ingrassato e cuciture incrociate a contrasto. Cuscini di seduta in poliuretano espanso con doppia densità e Memory Foam® più falda acrilica e fodera in tessuto idrorepellente. Cuscino di schienale in poliuretano espanso e fodera idrorepellente. Rivestimento cuscini in pelle o tessuti della selezione outdoor, completamente sfoderabile. Mostrine e piedini in acciaio inox e ottone satinati disponibili nella selezione finiture metalliche. Disponibile in opzione finitura poliestere lucida.

Structure in solid iroko wood assembled by interlocking and polyurethane glue, steel staples and zip in stainless steel. Seat frame in water-resistant multiply wood. Transparent polyurethane water-proof paint. Back structure and arms in poplar plywood honey-combed and covered with greased calf leather and crossed stitchings in contrast. Seat cushions in polyurethane foam in double density and Memory Foam® + acrylic layer and lining in water-repellent fabric. Back cushion in polyurethane foam and water-repellent lining. Cushions' removable cover in leather or fabric from outdoor collection. Decoration and feet in satinized stainless steel and satinized brass, available in the satinized metal finishing selection. Available also in polished polyester finishing.

● click here

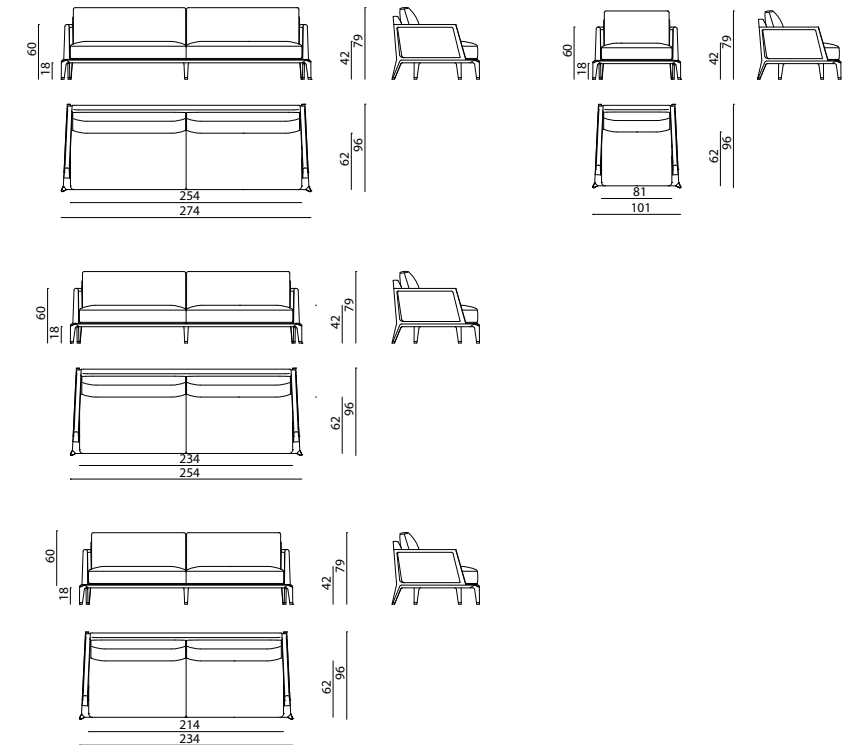



BRAMANTE

DIVANO E POLTRONA - SOFA AND ARMCHAIR
Samuele Mazza

Struttura portante realizzata in rattan naturale, legature in cuoio e fascette metalliche fin. inox lucido con incisione stemma araldico Visionnaire. Piano di seduta in multistrati marino. Cuscino di seduta e schienale in poliuretano espanso, densità variabile 25/30 kg/m³ con strato superiore di cm 4 in Memory Foam®. Rinfascio in falda acrilica 350 gr con foderatura di cotone. Cuscino sagomato bracciolo in densità 40 kg/m³ portante, con rinfascio in falda acrilica 350 gr e foderatura di cotone. Elementi metallici decorativi tubolari in finitura cromo o oro, con logo Visionnaire. Piedini lavorazione taglio laser, con motivo a ovali Visionnaire in acciaio inox. Rivestimento sfoderabile. Sconsigliato l'uso in ambienti completamente esposti alle intemperie.

Main structure in natural rattan, bindings in cuoio leather and metal clips in shiny stainless steel with Visionnaire engraved coat of arms. Seat support in marine plywood. Seat and back cushion in polyurethane, d. 25/30 kg/m³ with upper layer 4 cm in Memory Foam®. External acrylic layer 350 gr with cover in cotton. Shaped arm cushion d. 40 kg/m³ main, with acrylic layer 350 gr and lining in cotton. Decorative metal elements in chrome or gold finishing, with Visionnaire logo. Laser cut feet with Visionnaire oval decoration in stainless steel. Removable cover. Not recommended for use in environments completely exposed to the elements.

● click here

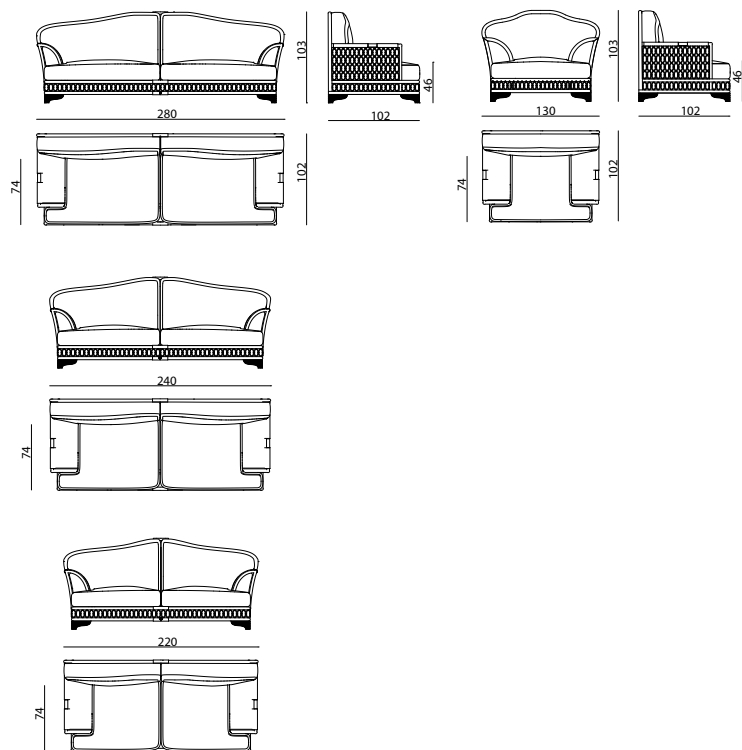

GREEN LIFE

DIVANO, POLTRONA - SOFA, ARMCHAIR
Roberto Tapinassi - Maurizio Manzoni

Struttura in massello di iroko assemblato con incastrati e colla poliuretana, punti metallici e zip in acciaio inox. Telaio di seduta in multistrati di betulla con bordo rivestito in cuoio ingrossato, verniciatura poliuretana trasparente da esterno. Pannelli di schienali e braccioli in cuoio rinforzato e ingrossato con lavorazione "a doghe" e cuciture a contrasto, assemblati con supporti in acciaio inox. Cuscini di seduta in poliuretano espanso a doppia densità e Memory Foam® più falda acrilica e fodera in tessuto idrorepellente. Cuscino di schienale in poliuretano espanso e fodera idrorepellente. Rivestimento cuscini in pelle o tessuto da esterni completamente sfoderabile. Fregi e piedini in acciaio inox satinato, disponibili nella selezione finiture metalliche. Disponibile in opzione finitura poliestere lucida.

Structure in solid iroko wood assembled by interlocking and polyurethane glue, steel staples and zip in stainless steel. Seat frame in birch multiply wood with border covered with greased calf leather, transparent polyurethane water-proof paint. Back panels and arms in greased and reinforced calf leather with striped manufacture and stitchings in contrast, assembled with supports in stainless steel. Seat cushions in polyurethane foam in double density and Memory Foam® + acrylic layer and lining in water-repellent fabric. Back cushion in polyurethane foam and water-repellent lining. Cushions' removable cover in outdoor leather or fabric. Decoration and feet in satinized stainless steel, available in the metal finishing selection. Available also in polished polyester finishing.

● click here

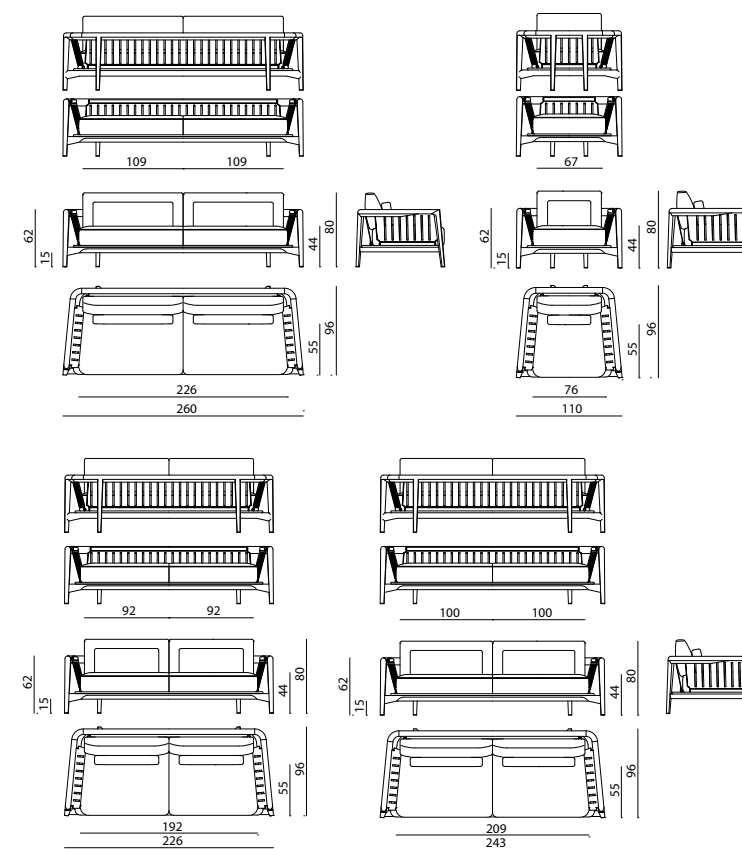

GALLOWAY

CHAISE-LONGUE - CHAISE-LONGUE

Roberto Tapinassi - Maurizio Manzoni

Struttura in legno di iroko massello e multistrato di betulla. Base in acciaio inox. Montante del bracciolo in fusione di alluminio lucidato e protetto con doppio strato di vernice trasparente, con logo in ottone inciso e curvato con finitura cromo. Imbottitura in poliuretano, Memory Foam®.

Versione compact: schienale con cuscini fissi. Rivestimento in tessuto o pelle con trattamento idrorepellente/ impermeabile. Eventuale parziale ricopertura di braccioli e schienale in pelle della selezione Dehors.

Versione freestyle: schienale con cuscini volanti. Rivestimento in tessuto della selezione Dehors. Rivestimento sfoderabile.

Structure in solid iroko wood and birch plywood. Base in stainless steel. Patches of the armrests in fusion of polished aluminium with double transparent coating film, with logo in engraved and curved brass with chrome finishing. Padding in polyurethane, Memory Foam®.

Compact version: Backrest with stable cushions. Upholstery in waterproof fabric or leather. Possibility to partially upholster the armrests and the backrest in leather from the Dehors selection.

Freestyle version: Backrest with loose cushions. Upholstery in waterproof fabric from the Dehors selection. Cover removable.

[click here](#)

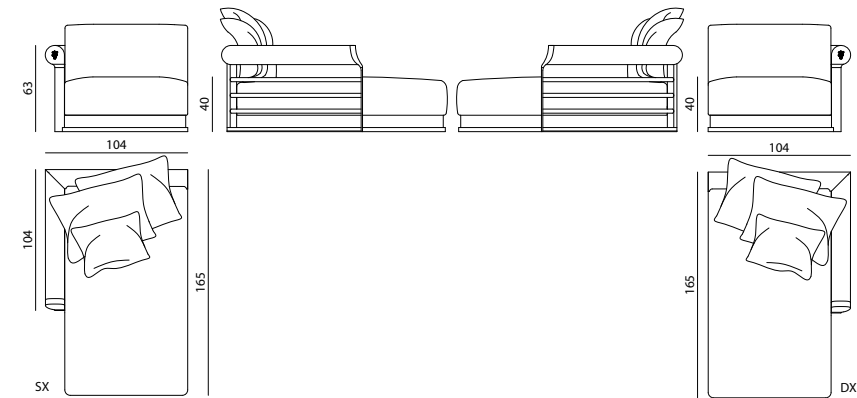

GALLOWAY

TAVOLO BASSO - LOW TABLE

Roberto Tapinassi - Maurizio Manzoni

Tavolo basso in legno di iroko massello e top in marmo. Piedini in acciaio inox. Ripiano portariviste in vetro fumè. Le parti in metallo sono disponibili nella selezione finiture metalliche.

Low table in iroko solid wood and top in marble. Feet in stainless steel. Magazine-holder shelf in smoked mirror. Metal parts can be lacquered in any colour included in the metal finish selection.

[click here](#)

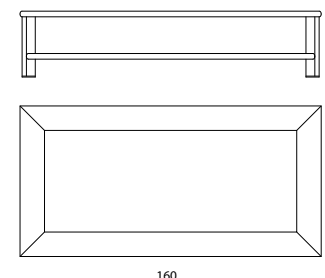
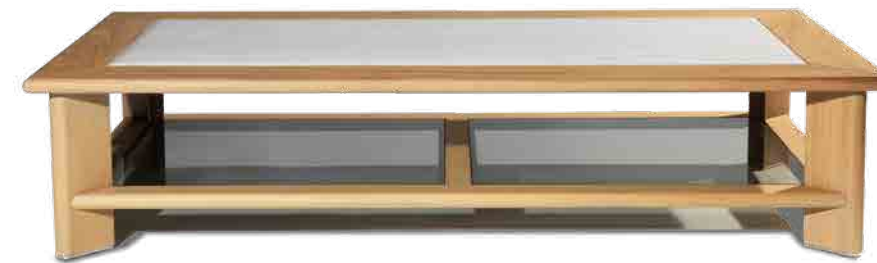

GALLOWAY

DIVANO - SOFA

Roberto Tapinassi - Maurizio Manzoni

Divano con struttura in legno di iroko massello e multistrato di betulla. Base in acciaio inox. Mostrina del bracciolo in fusione di alluminio lucidato e protetto con doppio strato di vernice trasparente con logo in ottone inciso e curvato con finitura cromo. Imbottitura in poliuretano, Memory Foam®.

Versione compact: schienale con cuscini fissi. Rivestimento in tessuto o pelle con trattamento idrorepellente/ impermeabile. Eventuale parziale ricopertura di braccioli e schienale in pelle della selezione Dehors.

Versione freestyle: schienale con cuscini volanti. Rivestimento in tessuto della selezione Dehors. Rivestimento sfoderabile.

Sofa with structure in solid iroko wood and birch plywood. Base in stainless steel. Patches of the armrests in fusion of polished aluminium with double transparent coating film, with logo in engraved and curved brass with chrome finishing. Padding in polyurethane, Memory Foam®.

Compact version: Backrest with stable cushions. Upholstery in waterproof fabric or leather. Possibility to partially upholster the armrests and the backrest in leather from the Dehors selection.

Freestyle version: Backrest with loose cushions. Upholstery in waterproof fabric from the Dehors selection. Cover removable.

[click here](#)

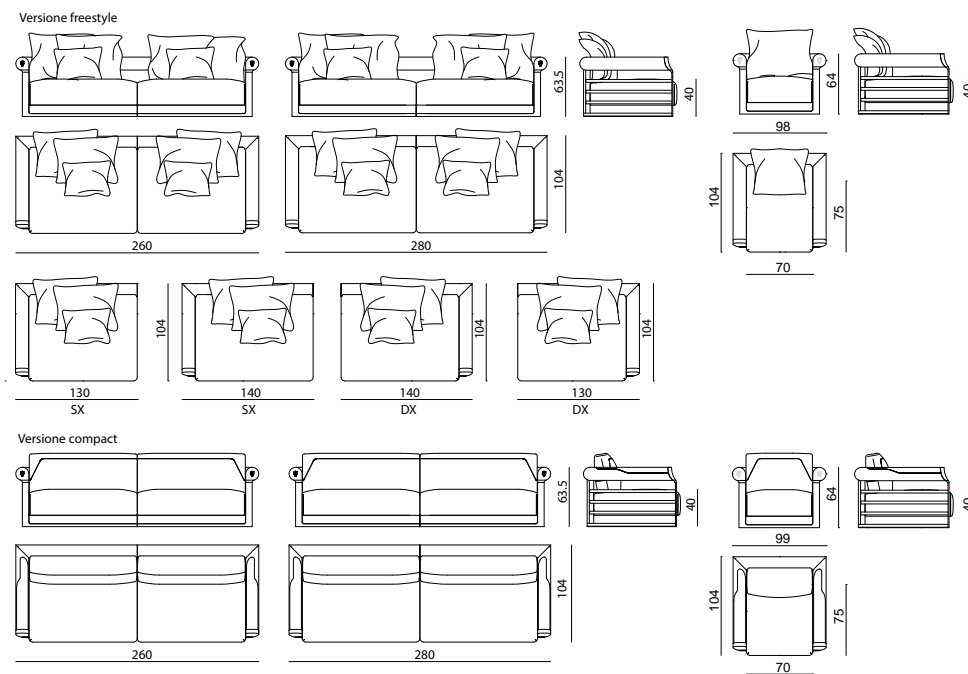



ILARIO

DIVANO, ELEMENTI COMPONENTI
SOFA, MODULAR ELEMENTS
m2atelier

Divano ed elementi componibili, outdoor e indoor. Fusto interno in compensati e multistrati fenolici, zoccolo in massello di iroko sagomato e angolari decorativi in fusione di alluminio da esterni, disponibili nella selezione finiture metalliche satiniate o verniciate a polveri (per esterni). Imbottitura in poliuretano espanso a diverse densità e falda acrilica rivestiti con guaina idrorepellente e tessuti o pelli della selezione Dehors Collection. Lo schienale bombato è impreziosito nella parte posteriore da elementi di sostegno in metallo, disponibili nella selezione finiture metalliche satiniate, rivestiti in pelle. Disponibile come divano, elemento laterale e pouff tondo che consente anche la composizione angolare in diverse angolazioni. Abbinabile a un tavolino laterale di servizio con top in pietra e bordo in legno iroko massello, con gamba in metallo, verniciata nero a polveri (per esterni), rivestita in pelle. Le parti in legno massello sono protette con vernici isolanti per esterni con finitura opaca. Bracciolo opzionale.

Sofa and modular elements for outdoor and indoor use. Internal structure in plywood and phenolic boards, plinth in shaped solid iroko and corner elements in aluminium cast treated for outdoor use, available in any lacquer of the satin metal finish selection or any of the powder coating in the outdoor metal finishing selection. Padding in polyurethane foam with different densities and acrylic fiber, covered by a water-proof film and upholstered in fabric or leather selected from the Dehor collection of materials. The rear of the bulging backrest is decorated with metal supporting elements, available in any lacquer of the polish metal finish selection, covered in leather. Available as sofa, lateral element and round pouf working as corner element. A matching lateral table is available: the table top is in stone with a profile in iroko solid wood and a metal leg, powder-coated black (for outdoor use), covered in leather. Solid wood parts are finished with a mat isolating lacquer suitable for outdoor products.



● click here

DIVANO COMPONENTI - ESEMPIO
MODULAR SOFA - EXAMPLE

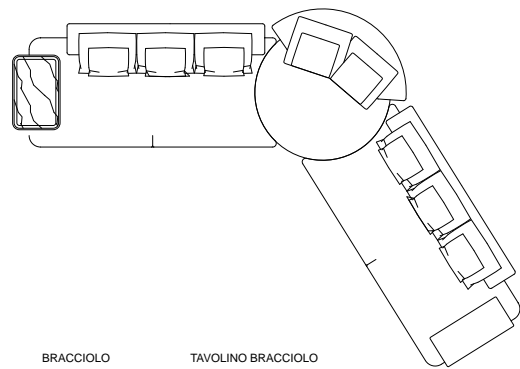

BRACCIOLO
ARMREST

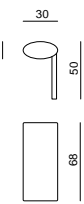

TAVOLINO BRACCIOLO
TABLE ARMREST

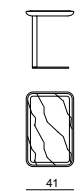

EL. ROTONDO
ROUND MODULE

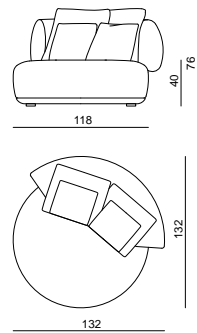

SHAPED MODULE RIGHT

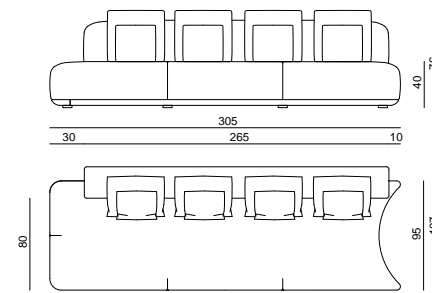

ILMSR09

ILMSR09L (CON BRACCIOLO SX / WITH LEFT ARMREST)

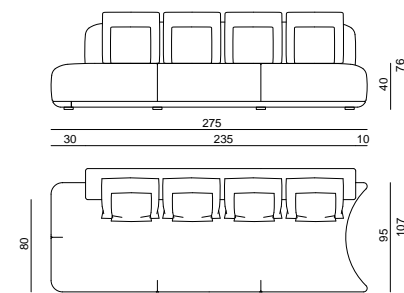

ILMSR11

ILMSR11L (CON BRACCIOLO SX / WITH LEFT ARMREST)

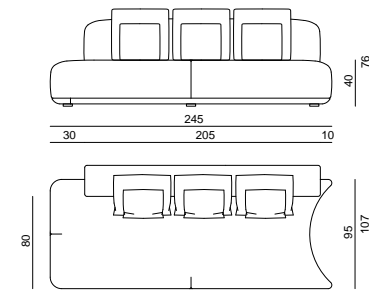

ILMSR13

ILMSR13L (CON BRACCIOLO SX / WITH LEFT ARMREST)

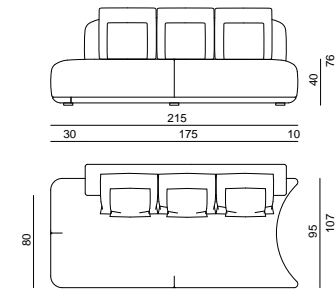

ILMSR15

ILMSR15L (CON BRACCIOLO SX / WITH LEFT ARMREST)

SHAPED MODULE LEFT

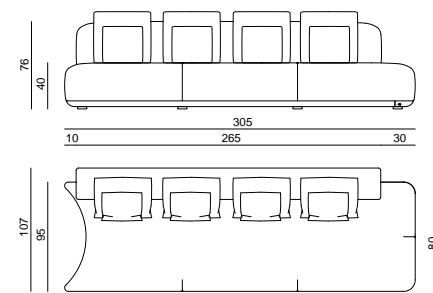

ILMSL10

ILMSL10R (CON BRACCIOLO DX / WITH RIGHT ARMREST)

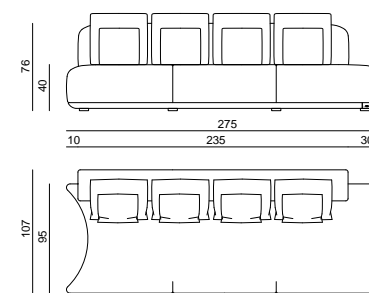

ILMSL12

ILMSL12R (CON BRACCIOLO DX / WITH RIGHT ARMREST)

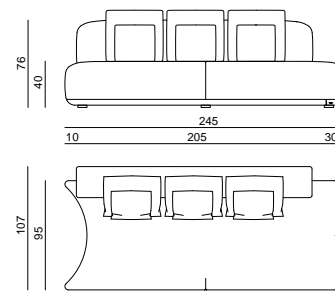

ILMSL14

ILMSL14R (CON BRACCIOLO DX / WITH RIGHT ARMREST)

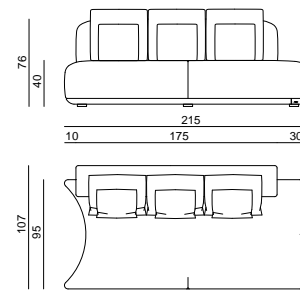

ILMSL16

ILMSL16R (CON BRACCIOLO DX / WITH RIGHT ARMREST)

EL. SAGOMATO DOPPIO
DOUBLE SHAPED MODULE

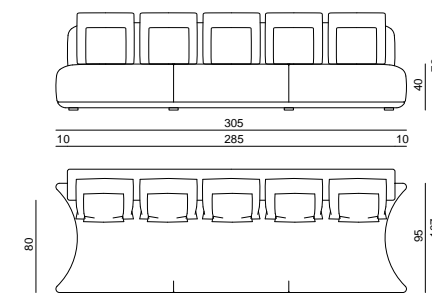

ILMDS05

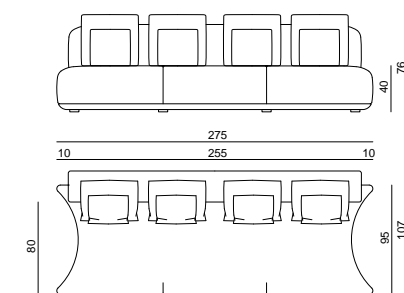

ILMDS06

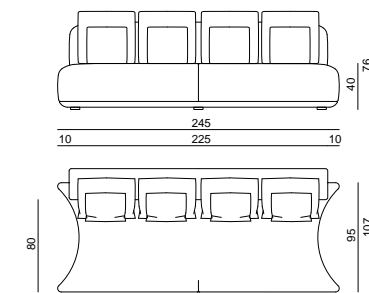

ILMDS07

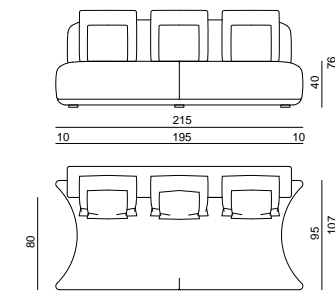

ILMDS08



DIVANO
SOFA

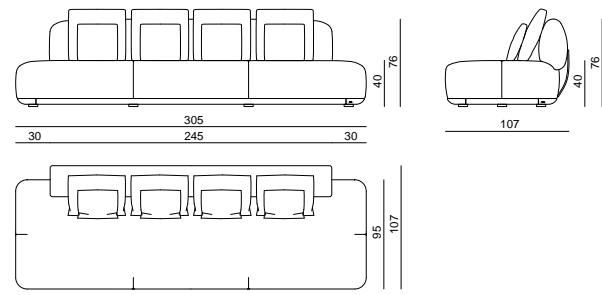

ILMW01

ILMW01L (CON BRACCIOLO SX / WITH LEFT ARMREST)

ILMW01R (CON BRACCIOLO DX / WITH RIGHT ARMREST)

ILMW01L+R (CON DUE BRACCIOLI / WITH TWO ARMRESTS)

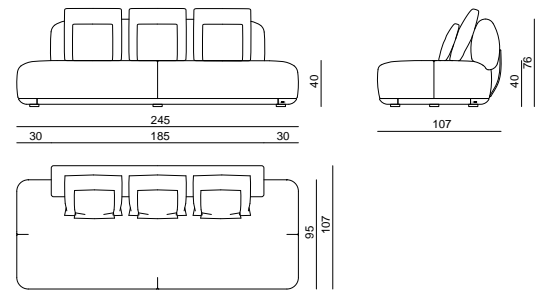

ILMW03

ILMW03L (CON BRACCIOLO SX / WITH LEFT ARMREST)

ILMW03R (CON BRACCIOLO DX / WITH RIGHT ARMREST)

ILMW03L+R (CON DUE BRACCIOLI / WITH TWO ARMRESTS)

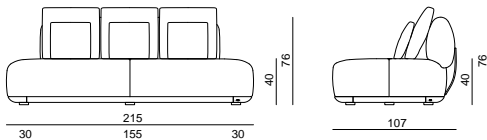

ILMW04

ILMW04L (CON BRACCIOLO SX / WITH LEFT ARMREST)

ILMW04R (CON BRACCIOLO DX / WITH RIGHT ARMREST)

ILMW04L+R (CON DUE BRACCIOLI / WITH TWO ARMRESTS)

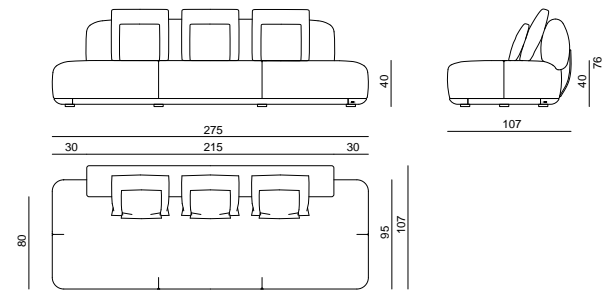

ILMW02

ILMW02L (CON BRACCIOLO SX / WITH LEFT ARMREST)

ILMW02R (CON BRACCIOLO DX / WITH RIGHT ARMREST)

ILMW02L+R (CON DUE BRACCIOLI / WITH TWO ARMRESTS)



WING

DIVANO - SOFA
m2atelier

Divano da outdoor e indoor. Fusto interno in compensati e multistrati fenolici, con base e mensola esterna in multistrati impiallacciato in iroko naturale, bordato con profilo in alluminio bombato, disponibile verniciato a polveri (per esterni) e decorato con fibbie in ottone massiccio, disponibile nella selezione finiture metalliche lucide. Imbottitura in poliuretano espanso a diverse densità e falda acrilica rivestiti con guaina idrorepellente e tessuti o pelli della selezione Dehors Collection. La mensola perimetrale è sostenuta da gambe in fusione di alluminio, disponibili verniciate a polveri (per esterni) e completato da una griglia decorativa in alluminio, disponibile verniciata a polveri (per esterni) o nella selezione finiture metalliche satinato. Le parti in legno sono protette con vernici isolanti per esterni con finitura opaca.

Sofa for indoor and outdoor use. Internal structure in plywood and phenolic boards, with base and external shelf in plywood finished with natural iroko veneer, decorated with a bulging aluminium profile, available in any of the powder coating in the outdoor metal finish selection, and buckles in solid brass, available in any of the powder coating in the outdoor metal finish selection, and equipped with a decorative netting in aluminium, available in any of the powder coating in the outdoor metal finish selection, or in any lacquer of the satin metal finish selection. Solid wood parts are finished with a mat isolating lacquer suitable for outdoor products.

● [click here](#)

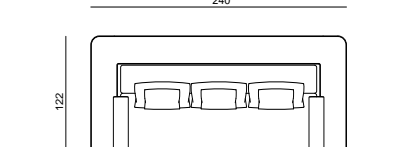
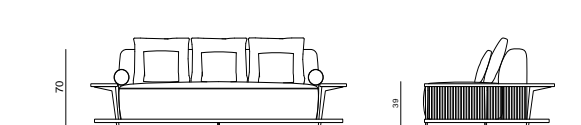
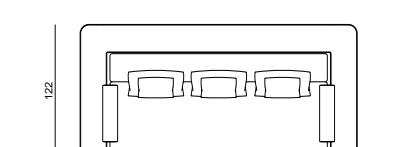
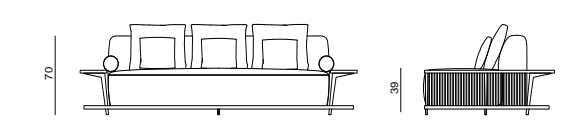
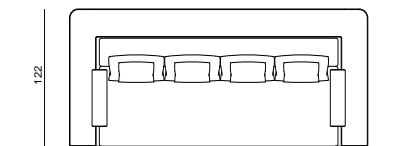
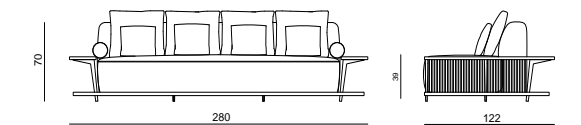
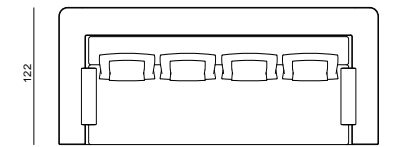
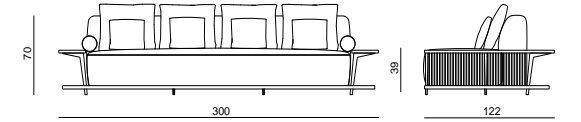



KATHRYN OUTDOOR

DIVANO, POLTRONCINA - SOFA, ARMCHAIR
Giuseppe Viganò

Divano e poltroncina outdoor, struttura di base in multistrati marino curvato rivestito teak contenente un cuscino di seduta in poliuretano espanso in diverse densità, imbottito e rivestito in tessuto o pelle da esterno. Schienale curvo formato da struttura in ottone e acciaio inox, intrecciata in corda di lino e bacchette di teak massello. Stemma decorativo sui braccioli con nappe in cuoio e ottone. Cuscini volanti per lo schienale in fiocco acrilico in pelle o tessuto da esterno.

Outdoor sofa and armchair, base structure in curved marine plywood covered with teak containing a seat cushion in polyurethane foam in different densities, upholstered in fabric or leather for outdoor use. Curved backrest made of brass and stainless steel structure, woven with natural linen rope and solid teak rods. Decorative coat of arms with leather and brass tassels. Loose cushions for the back in acrylic flakes, in leather or outdoor fabric.

● [click here](#)

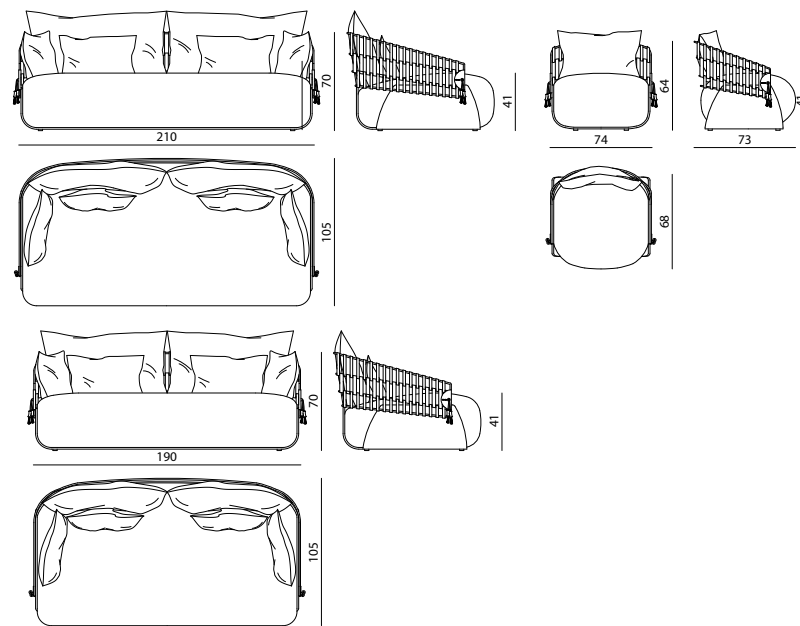

KATHRYN OUTDOOR

POUF - POUFFE
Giuseppe Viganò

Pouf outdoor, struttura di base in multistrati marino curvato rivestito teak contenente un cuscino di seduta in poliuretano espanso in diverse densità, imbottito in tessuto o pelle da esterno.

Outdoor pouffe, base structure in curved marine plywood covered with teak containing a seat cushion in polyurethane foam in different densities, upholstered in fabric or leather for outdoor use.

● [click here](#)

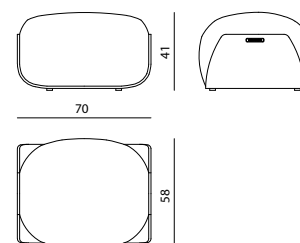

KATHRYN OUTDOOR

LAMPADA DA TERRA OUTDOOR - OUTDOOR FLOOR LAMP
Giuseppe Viganò

Lampada da terra outdoor, struttura in multistrati marino curvato rivestito teak contenente una sfera luminosa in polietilene con grado di isolamento IP55, portalamпада E27 max 25W, cavo di alimentazione con spina isolata SENZA interruttore.

Outdoor floor lamp, structure in curved marine plywood covered in teak containing a luminous sphere in polyethylene with IP55 insulation degree, E27 lampholder max 25W, power cord with insulated plug WITHOUT switch.

● [click here](#)

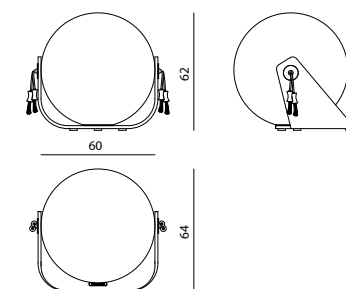

PALM BEACH

CHAISE-LONGUE - CHAISE-LONGUE

La Conca

Divano in rattan sintetico intrecciato a mano, struttura portante in traliccio di alluminio con schienali innestati nella base tramite fissaggio meccanico, posizionabili a progetto. Gli schienali sono disponibili con intreccio pied-de-poule a due tonalità oppure con trama "paglia di Vienna" monocromatico. La parte superiore degli schienali è decorata con borchie in ottone cromato con logo inciso. Cuscino di seduta in poliuretano da esterni a doppia densità e falda acrilica. Cuscini volanti in poliuretano, rivestimento in tessuti outdoor. Piedi in acciaio inox AISI 316 lavorato al laser. Il rattan sintetico è disponibile nei colori white gold, honey gold e bronze.

Sofa hand-woven in synthetic rattan. Main structure in aluminium truss with backrests joined to the base by means of mechanical fastenings (fixed as per project). Backrests available in pied-de-poule pattern in 2 shades or with Vienna straw patten in one colour. The upper part of the backrests is decorated with chromed brass studs with engraved logo. Seat cushion in polyurethane (suitable for outdoor) in double density and acrylic fibre. Loose cushions in polyurethane, upholstery in fabric or leather suitable for outdoor. Feet in laser-finished stainless steel AISI 316. Synthetic rattan is available in white gold, honey gold and bronze.

[click here](#)

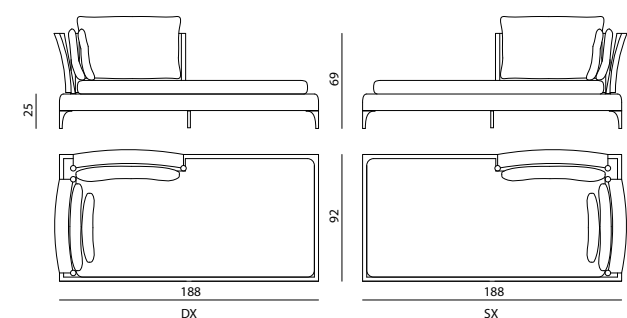

PALM BEACH

DIVANO, DIVANO COMPONIBILE
SOFA, MODULAR SOFA

La Conca

Divano in rattan sintetico intrecciato a mano, struttura portante in traliccio di alluminio con schienali innestati nella base tramite fissaggio meccanico, posizionabili a progetto. Gli schienali sono disponibili con intreccio pied-de-poule a due tonalità oppure con trama "paglia di Vienna" monocromatico. La parte superiore degli schienali è decorata con borchie in ottone cromato con logo inciso. Cuscino di seduta in poliuretano da esterni a doppia densità e falda acrilica. Cuscini volanti in poliuretano, rivestimento in tessuti outdoor. Piedi in acciaio inox AISI 316 lavorato al laser. Il rattan sintetico è disponibile nei colori white gold, honey gold e bronze.

Sofa hand-woven in synthetic rattan. Main structure in aluminium truss with backrests joined to the base by means of mechanical fastenings (fixed as per project). Backrests available in pied-de-poule pattern in 2 shades or with Vienna straw patten in one colour. The upper part of the backrests is decorated with chromed brass studs with engraved logo. Seat cushion in polyurethane (suitable for outdoor) in double density and acrylic fibre. Loose cushions in polyurethane, upholstery in fabric or leather suitable for outdoor. Feet in laser-finished stainless steel AISI 316. Synthetic rattan is available in white gold, honey gold and bronze.

[click here](#)

Pied-de-poule:

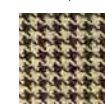

1A - honey gold-bronze



1B - white gold-honey gold

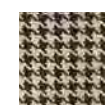

1C - white gold-bronze

Paglia di Vienna:

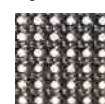

2A - bronze



2B - white gold



2C - honey gold

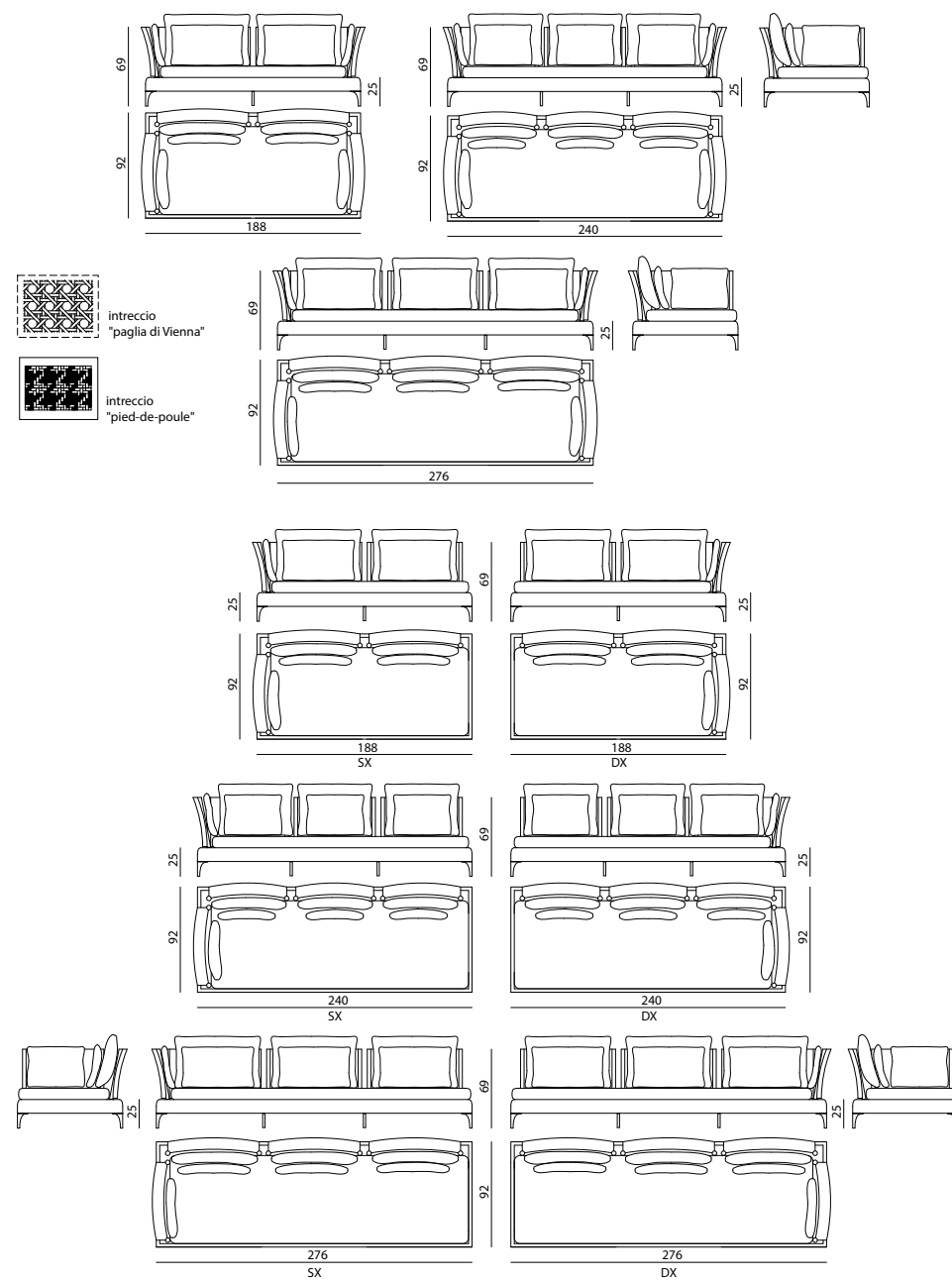

PALM BEACH

TAVOLO BASSO - LOW TABLE

La Conca

Tavolo basso in rattan sintetico intrecciato a mano, struttura portante in traliccio di alluminio, top parte in marmo ad incasso e parte con pouf in poliuretano da esterni a doppia densità e falda acrilica, rivestito in tessuti outdoor. Piedi in acciaio inox AISI 316 lavorato al laser. Il rattan sintetico è disponibile nei colori white gold, honey gold e bronze.

Low table in hand-woven synthetic rattan, main structure in aluminium truss, small built-in top in marble and pouffe in polyurethane (suitable for outdoor) in double densities and acrylic fibre. Upholstery in leather or fabric. Feet in laser-cut stainless steel AISI 316 available in chrome, gold, champagne, bronze, Siena, black nickel and gunmetal finishing. Synthetic rattan is available in white gold, honey gold and bronze.

[click here](#)

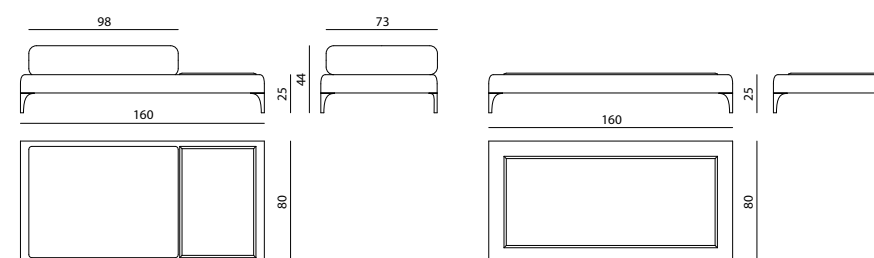



STANKAR

DIVANO, POLTRONA - SOFA, ARMCHAIR

La Conca

Divano e poltrona rivestiti in pelle o tessuto della selezione outdoor, telaio in metallo zincato e verniciato a polveri con cinghiatura elastica per la seduta, intrecciato con corda in canapa naturale e fili in lurex oro e argento. Seduta a tappezzeria fissa in poliuretano a densità differenziate protetto con telo impermeabile. Cuscini volanti in fiocco acrilico. Elementi decorativi posteriori in acciaio inox e fregi in alluminio disponibili nella selezione finiture metalliche.

Sofa and armchair upholstered in leather or fabric from outdoor selection, frame in lacquered and galvanised metal interwoven with hempen rope and lurex threads (gold and silver), with elastic spring belts on seat structure. Seat with padding in polyurethane with different densities protected by a water-resistant cover. Loose cushions in acrylic fiber. Rearback decorative elements in stainless steel and knobs in aluminium available with any finish included in the metal finish selection.

[click here](#)

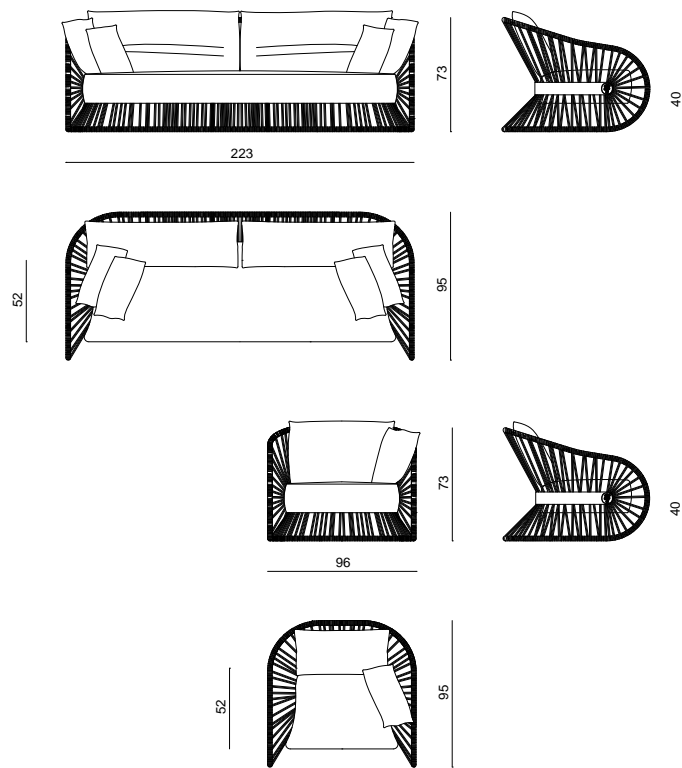

STANKAR

POLTRONA A DONDOLO - ROCKING ARMCHAIR

La Conca

Poltrona a dondolo rivestiti in pelle o tessuto della selezione outdoor, telaio in metallo zincato e verniciato a polveri con cinghiatura elastica per la seduta, intrecciato con corda in canapa naturale e fili in lurex oro e argento. Seduta a tappezzeria fissa in poliuretano a densità differenziate protetto con telo impermeabile. Cuscini volanti in fiocco acrilico. Elementi decorativi posteriori in acciaio inox e fregi in alluminio disponibili nella selezione finiture metalliche.

Rocking armchair upholstered in leather or fabric from outdoor selection, frame in lacquered and galvanised metal interwoven with hempen rope and lurex threads (gold and silver), with elastic spring belts on seat structure. Seat with padding in polyurethane with different densities protected by a water-resistant cover. Loose cushions in acrylic fiber. Rearback decorative elements in stainless steel and knobs in aluminium available with any finish included in the metal finish selection.

[click here](#)

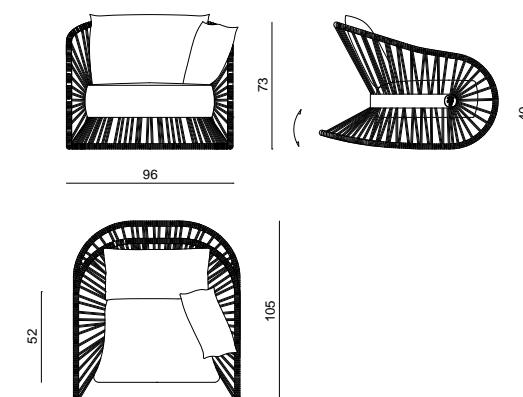

STANKAR

TAVOLO BASSO - LOW TABLE

La Conca

Tavolo basso con struttura metallica zincata e verniciata a polveri, intrecciata con corda in canapa naturale e fili in lurex oro e argento. Top in pietra lavica smaltata a fuoco colore antracite.

Outdoor low table, frame in lacquered and galvanised metal interwoven with hempen rope and lurex threads. Top in enamelled lava stone, anthracite colour.

[click here](#)

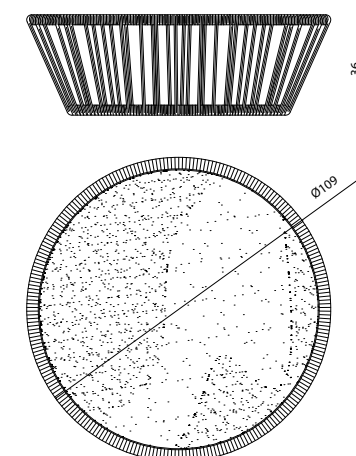



AYDON

SDRAIO - BEACH CHAIR
design Alessandro La Spada

Sdraio da esterno, regolabile e pieghevole. Telaio ferro con trattamento protettivo a cataforesi e smalto. Finiture di torneria in alluminio lucidato e protetto con doppio strato di vernice trasparente, opzione lacca oro/bronzo. Seduta in tessuto con trattamento idrorepellente/impermeabile.

Beach chair, adjustable and folding. Structure in iron, cathaphoresis and paint coating. Feet and tips in polished aluminium with double transparent coating film, optional gold or bronze finishing. Seat in waterproof fabric.

● [click here](#)

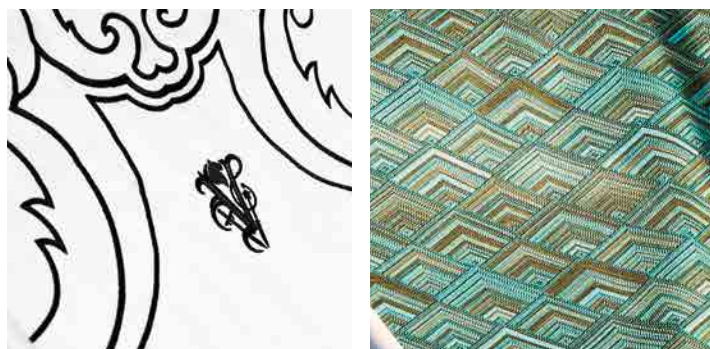
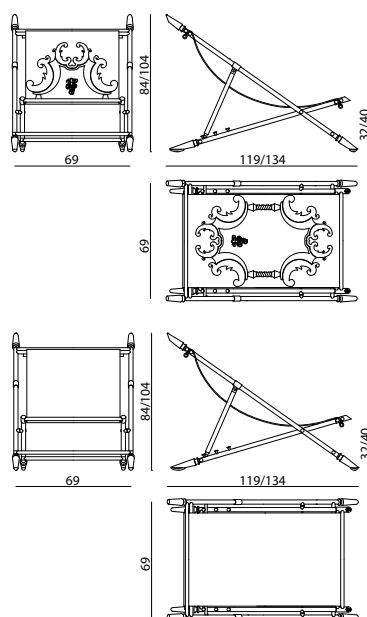

EIROS

LETTINO - SUN BED
Alessandro La Spada

Struttura in alluminio verniciato a polveri. Piedi anteriori in alluminio lucidato protetto da doppio strato di vernice trasparente, opzione lacca oro/bronzo oppure verniciati a polveri in tinta col telaio. Cuscini in poliuretano espanso e falda acrilica. Rivestimento in tessuto o pelle con logo visionnaire ricamato, trattamento idrorepellente/impermeabile. Schienale e poggiatesta regolabili su più posizioni con supporti in ottone. Munito di ruote in acciaio con battistrada in nylon.

Structure in powder painted aluminium. Front legs in polished aluminium with double transparent coating film, optional gold or bronze finishing or powder painted. Cushions in polyurethane foam and acrylic layers. Upholstery in waterproof leather or fabric, embroidered Visionnaire logo. Backrest and footrest adjustable in several positions with supports in brass. Bed provided of wheels in stainless steel with tread in nylon.

● [click here](#)

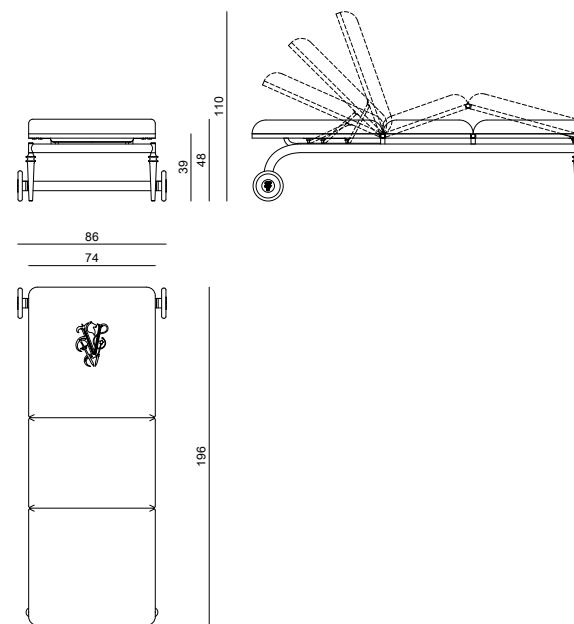

FOIL

LETTINO - DAYBED
m2atelier

Lettingo prendisole in massello di iroko, con telaio interno in metallo trattato per outdoor e sottile imbottitura acrilica, rivestito con guaina idrorepellente e tessuti o pelli della selezione Dehors Collection. Cuscino appoggiatesta regolabile con cinture in pelle e contrappeso in acciaio inox e pelle. Le gambe in iroko massello sono trattate con finitura per esterni opaca e completate da piedini in acciaio inox. Le parti in metallo sono disponibili verniciate a polveri (per esterni) o nella selezione finiture metalliche satinare. Il prodotto è impilabile. Disponibile in opzione telo in spugna rimovibile e lavabile con bordi in pelle e cuffia per appoggiatesta con logo ricamato.

Sunbed in iroko solid wood, with internal frame in metal finished with outdoor treatment and a thin padding in acrylic fiber covered with a water-proof film. Upholstery in fabric or leather from dehors collection of materials. Adjustable headrest cushion with belts in leather and counterweight in stainless steel and leather. Legs in iroko solid wood treated for outdoor with mat finish and completed with stainless steel feet. Metal parts available with any of the powder coating in the outdoor metal finish selection or in any lacquer of the satin metal finish selection. The beds can be stacked. Optionally available: removable and washable terry cloth with leather trim and headrest cover with embroidered logo.

● [click here](#)

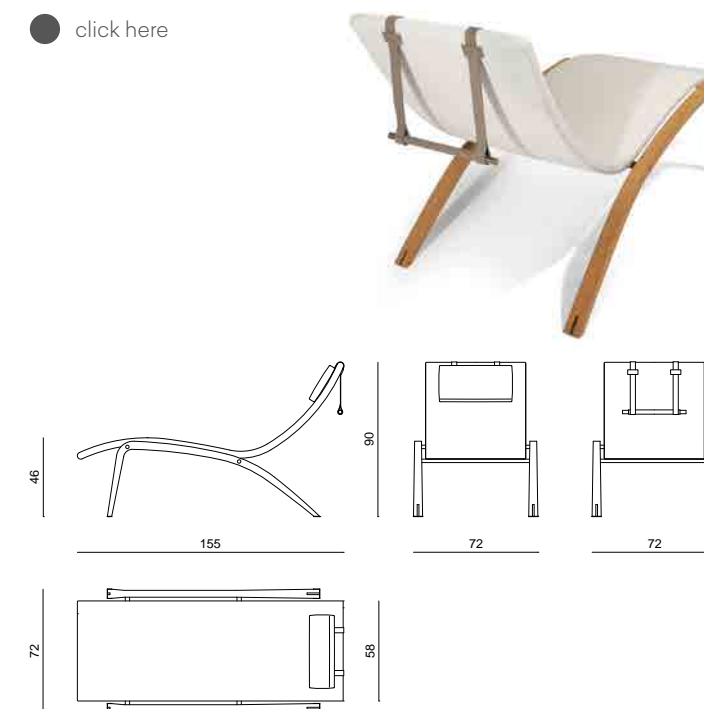



FARNESE

LETTINO - DAYBED
Samuele Mazza

Struttura portante realizzata in rattan naturale con legature in cuoio e fascette metalliche in finitura inox lucido con incisione stemma araldico Visionnaire. Piano di appoggio del materasso in legno multistrati marino. Materasso in poliuretano a densità differenziate rivestito in tessuti della selezione outdoor, completamente sfoderabile. Piedi e tubolari decorativi in metallo disponibili nella selezione finiture metalliche. Disponibile con cappottina parasole richiudibile. Sconsigliato l'uso in ambienti completamente esposti alle intemperie.

Main structure made in natural wicker, belts in leather and metal clips in polish stainless steel with Visionnaire logo engraved. Mattress resting on a supporting panel in marine plywood. Mattress in polyurethane foam with different densities, upholstered with a cover made in outdoor fabric, totally removable. Feet and decorative tubular elements in metal can be lacquered in any colour of the metal finish selection. Optional folding roof available. The use in locations entirely exposed to the weather is not recommended.

click here

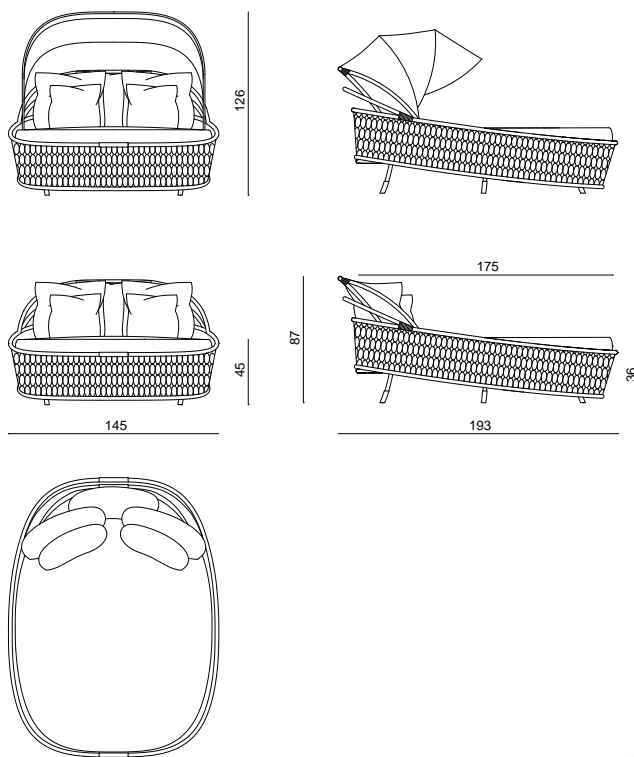

REDDING

LETTINO - DAYBED
Alessandro La Spada

Letto da outdoor in mogano, disponibile in finitura lucida o opaca. La struttura è ottenuta per scolpitura di elementi in massello di mogano arrotondati e lavorati, con piedini e ruote in acciaio inox AISI 316 conificato e lucidato. Lo schienale è regolabile in tre posizioni, il materassino, munito di poggiatesta regolabile e asportabile, è sfoderabile per il lavaggio. Il materassino è assicurato al telaio in legno dogato attraverso clips magnetiche ed è realizzato in materiale drenante per una completa esposizione agli agenti atmosferici. Le parti in metallo sono disponibili verniciate a polveri (per esterni) o nella selezione finiture metalliche lucide.

Outdoor sunbed in mahogany wood, available with polish or mat finish. Structure obtained by carving solid mahogany blocks, then rounded and finished. Feet and wheels in polish AISI 316 stainless steel with conic shape. Backrest with adjustable height (3 positions), mattress, adjustable and removable headrest, removable cover. The mattress is secured to the wooden slatted structure by means of magnetic clips and it is made in a draining material, guaranteeing high resistance to weathering. Metal parts available with any of the powder coating in the outdoor metal finish selection or in any lacquer of the polish metal finish selection.

click here

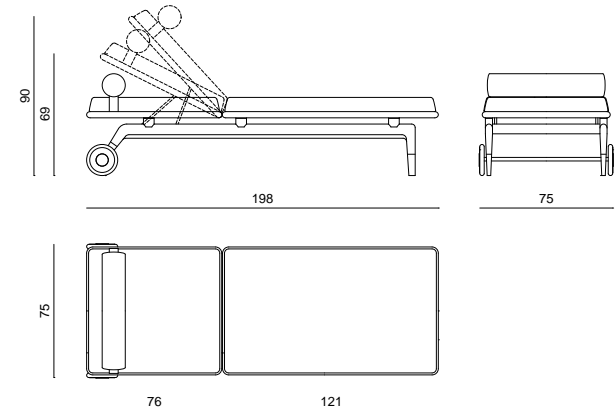

REDDING

TAVOLO BASSO - LOW TABLE
Alessandro La Spada

Tavolino da outdoor in mogano, disponibile in finitura lucida o opaca. La struttura è ottenuta per scolpitura di elementi in massello di mogano arrotondati e lavorati, con piedini in acciaio inox AISI 316 conificato e lucidato. Il top in quarzite Patagonia è semi-incassato e lavorato con bordo smussato. Le parti in metallo sono disponibili verniciate a polveri (per esterni) o nella selezione finiture metalliche lucide.

Outdoor table in mahogany, available with polish or mat finish. Structure obtained by carving solid mahogany blocks, then rounded and finished. Feet and wheels in polish AISI 316 stainless steel with conic shape. The top in Patagonia quartz is semi-recessed and finished with a bevelled edge. Metal parts available with any of the powder coating in the outdoor metal finish selection or in any lacquer of the polish metal finish selection.

click here

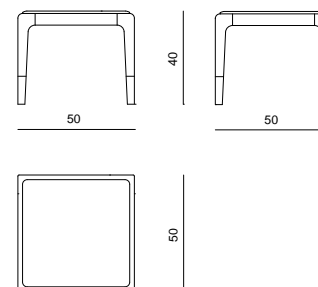



SIESTA

LETTINO - DAYBED
m2atelier

Letto tondo da outdoor e indoor. Fusto interno in compensati e multistrati fenolici, con imbottitura in poliuretano espanso a diverse densità e falda acrilica rivestiti con guaina idrorepellente e tessuti o pelli della selezione Dehors Collection. Lo schienale bombato, completo di cuscini volanti di diverse dimensioni in fiocco acrilico, nella parte posteriore presenta elementi di sostegno in metallo rivestiti in pelle. Disponibile in opzione un ombrello parasole orientabile con stelo e telaio in acciaio inox rivestito in tessuto e passamaneria della selezione Dehors Collection. Le parti in metallo sono disponibili verniciate a polveri (per esterni) o nella selezione finiture metalliche satiniate.

Circular small bed for indoor and outdoor use. Internal frame in plywood and phenolic boards, with padding in polyurethane foam with different densities and acrylic fiber, upholstered in fabric or leather from the Dehors collection of materials. The rear of the bulging backrest, including loose cushions in different dimension in soft acrylic flakes, is decorated with metal elements covered in leather. An optional sun umbrella with adjustable orientation is available. The umbrella has a stem and a frame in stainless steel, a cover in fabric decorated with trimming from the Dehors collection of materials. Metal parts available in any of the powder coating in the outdoor metal finish selection or in any lacquer of the satin metal finish selection.

● click here



SUN UMBRELLA ADJUSTMENT

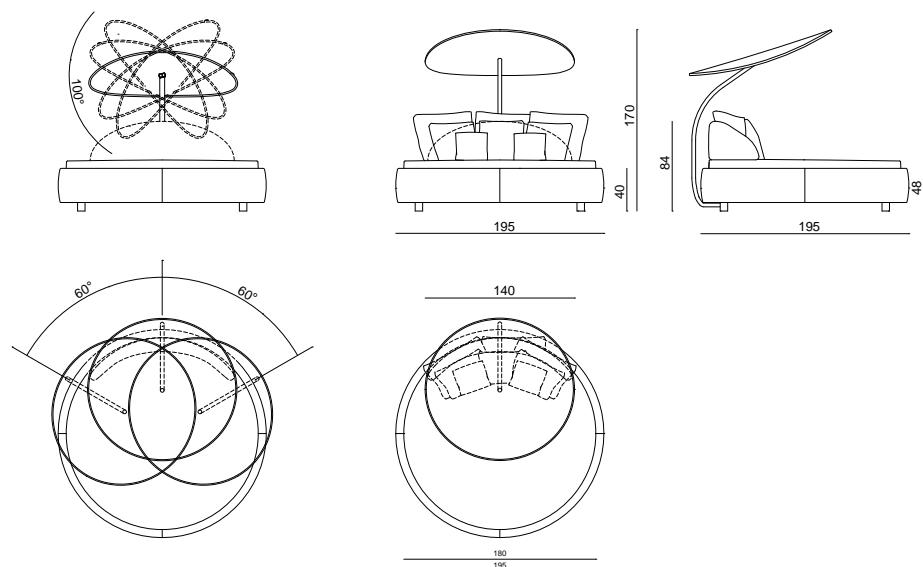

SVEVA

CHAISE-LONGUE - CHAISE-LONGUE
Giuseppe Viganò

Struttura in multistrati di pioppo con rinforzo in metallo per fissaggio gambe. Imbottitura poliuretano espanso a doppia densità, 40 kg/m³ portante e 30 kg/m³. Profilo esterno poliuretano densità 70 kg/m³ portante. Foderatura in falda acrilica 100 gr. Guanciale appoggiatesta cm 60x30 in piuma con filetto e con fascette di fissaggio. Rivestimento in tessuto o pelle con filetto a contrasto. Cappottina a soffietto, ad inclinazione regolabile, in tessuto. Gambe e tornerie in alluminio finitura lucida.

Structure in poplar plywood with support in metal for legs fixing. Padding in polyurethane in double density, 40 kg/m³ (rigid) and 30 kg/m³. External profile in polyurethane d. 70 kg/m³ (rigid). Acrylic layer 100 gr. Headrest cushion cm. 60x30 in feather with pipings and with fixing bands. Upholstered with fabric or leather and with pipings. Sliding roof with adjustable inclination in fabric. Legs and turnings in shiny aluminium.

vedi anche/see also SVEVA chaise-longue capitonné

● click here

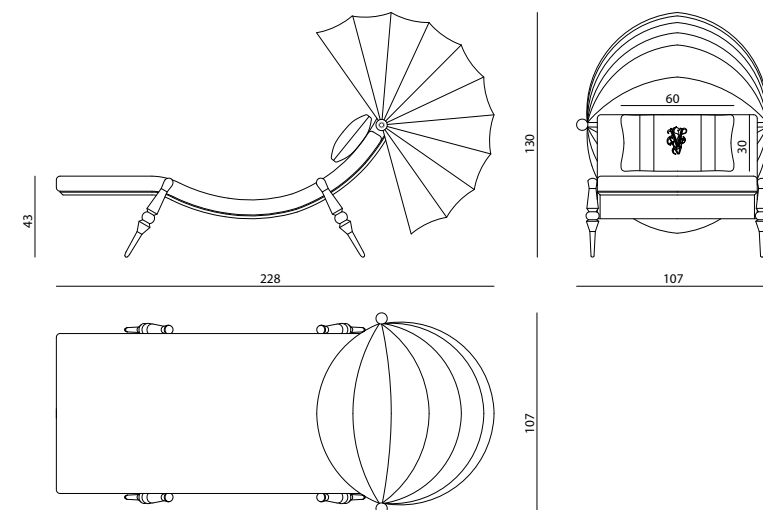



ALBATROS DEHORS

SGABELLO - STOOL
Alessandro La Spada

Sgabello con schienale, monoscocca in legno multistrati curvato, con gambe in tubo metallico di acciaio inox. Rivestimento in pelle o tessuto con filetti sui bordi. Le parti in metallo sono disponibili nella selezione finiture metalliche oppure nella versione heavy-duty verniciato a polveri (per esterni).

Stool with small backrest, whole structure in curved plywood, with legs in stainless steel tube. Upholstery in leather or fabric and matching pipings on the edges. Metal parts can be lacquered in any colour included in the metal finish selection or in powder painting finishing.

vedi anche/see also ALBATROS sgabello-stool

● click here

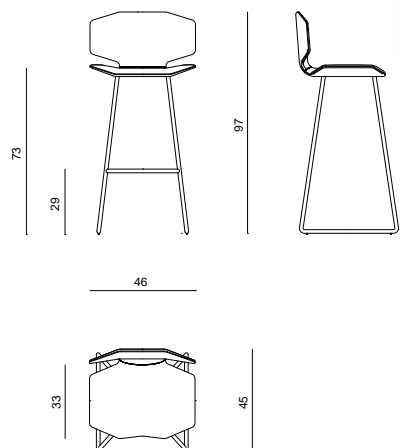

AMINTA DEHORS

SEDIA OUTDOOR - OUTDOOR CHAIR
Giuseppe Viganò

Sedia in acciaio inox con seduta e cuscino volante di schienale tappezzati in pelle o tessuto outdoor. Sedile dotato di cinghie elastiche tappezzato e imbottito in poliuretano. Gambe in tubo conificato. Il telaio e le gambe sono disponibili nella selezione finiture metalliche lucide. Versione heavy-duty con telaio e gambe verniciati a polveri (per esterni), consigliato per ambiente marino e nautica.

Outdoor chair in stainless steel with upholstered seat and back loose cushion in leather or fabric (outdoor samples). Legs in polished tubular steel with conic section. Seat equipped with elastic spring belts, padded in polyurethane. The frame and legs can be lacquered in any colour included in the polish metal finish selection. Heavy-duty version: frame and legs in powder painting, recommended for marine and nautical environment.

vedi anche/see also AMINTA sedia-chair

● click here

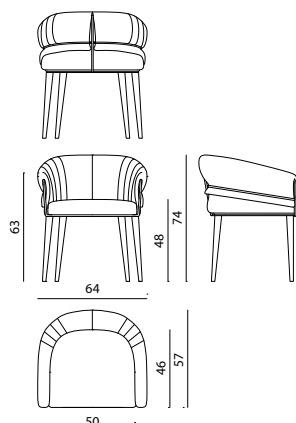

ASTRID DEHORS

SEDIA OUTDOOR - OUTDOOR CHAIR
Alessandro La Spada

Sedia imbottita con scocca in legno multistrati marino curvato, imbottita e rivestita in pelle o tessuto della selezione outdoor. Gambe in fusione di alluminio satinato disponibile nella selezione finiture metalliche oppure verniciato a polveri (per esterni). Lo schienale è disponibile anche nella versione "quilted" in pelle con ricamo con disegno foliage, leggermente imbottito.

Padded chair with curved marine plywood shell upholstered and covered in outdoor leather or fabric. Legs in aluminium cast available in the metal finishing selection or in powder painting finishing. The back is also available in the "quilted" version in leather with embroidery with a slightly padded, foliage design.

vedi anche/see also ASTRID sedia-chair

● click here

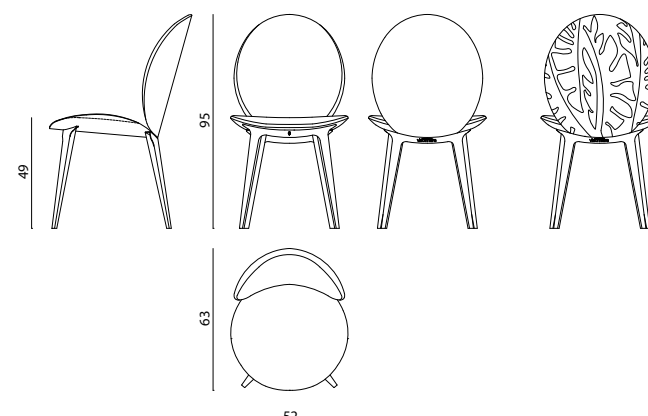

CLEM DEHORS

SEDIA OUTDOOR - OUTDOOR CHAIR
Alessandro La Spada

Telaio in tubo di ottone cromato a sezione quadra con logo Visionnaire inciso, struttura di seduta e schienale in legno multistrato curvato, imbottito in poliuretano a densità differenziate e falda acrilica. Rivestimento fisso in pelle o tessuto della selezione outdoor. Le parti metalliche sono disponibili nella selezione finiture metalliche satinato. Versione heavy-duty con telaio e gambe verniciati a polveri (per esterni), consigliato per ambiente marino e nautica.

Frame in squared brass pipe with engraved Visionnaire logo, seat structure and backrest in curved plywood padded in polyurethane in different densities and acrylic fibre. Fixed upholstery in outdoor leather or fabric. Metal parts available in the satinized metal finishing selection. Heavy-duty version: frame and legs in powder painting, recommended for marine and nautical environment.

vedi anche/see also CLEM sedia-chair

● click here

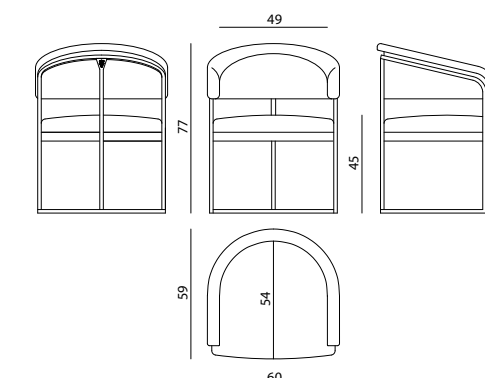



CLEM DEHORS

SGABELLO - STOOL
Alessandro La Spada

Telaio in tubo di ottone cromato a sezione quadra con logo Visionnaire inciso, poggiatesta in acciaio inox, struttura di seduta e schienale in legno multistrato curvato, imbottito in poliuretano a densità differenziate e falda acrilica. Rivestimento fisso in pelle o tessuto della selezione outdoor. Le parti metalliche sono disponibili nella selezione finiture metalliche satinate. Versione heavy-duty con telaio e gambe verniciati a polveri (per esterni), consigliato per ambiente marino e nautica.

Frame in squared brass pipe with engraved Visionnaire logo, footrest in stainless steel, seat structure and backrest in curved plywood padded in polyurethane in different densities and acrylic fibre. Fixed upholstery in outdoor leather or fabric. Metal parts available in the satinized metal finishing selection. Heavy-duty version: frame and legs in powder painting, recommended for marine and nautical environment.

vedi anche/see also CLEM sgabello-stool

● click here



CONEY ISLAND

SEDIA, POLTRONCINA - CHAIR, ARMCHAIR
Samuele Mazza

Poltroncina in rattan sintetico intrecciato a mano con trama "paglia di Vienna" su telaio in traliccio di alluminio. Piedini in alluminio lucidato protetto da vernice trasparente, disponibili nella selezione finiture metalliche. Sedile imbottito in poliuretano e falda acrilica. Cuscino schienale in poliuretano elastico e falda acrilica. Rivestimento in tessuti outdoor con filetto in tinta. Il rattan sintetico è disponibile nei colori white gold, honey gold e bronze.

Chair in hand-woven synthetic rattan giving a "Vienna straw" pattern effect, frame in aluminium truss. Feet in polished aluminium with transparent protective coating, available with any lacquer of the metal lacquer finish selection. Back cushion in elastic polyurethane and acrylic fibre. Upholstery in outdoor fabric with pipings. Synthetic rattan is available in white gold, honey gold and bronze.

● click here

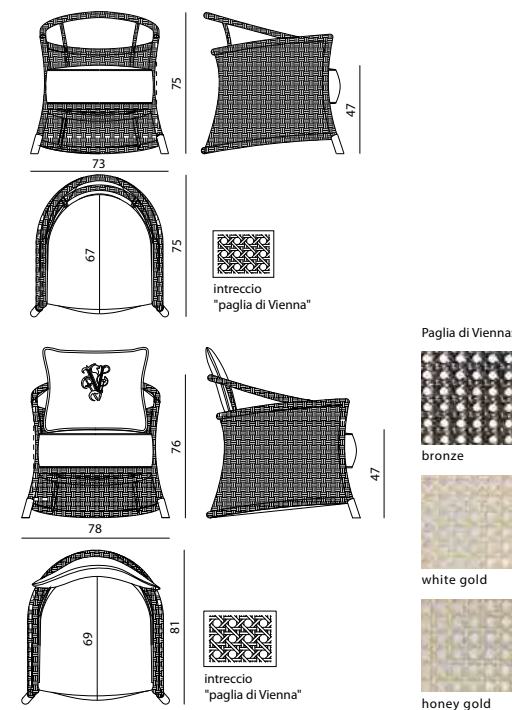

ELEANOR DEHORS

SEDIA OUTDOOR - OUTDOOR CHAIR
Giuseppe Viganò

Sedia in tubo di acciaio inox lucido curvato e saldato in unico pezzo, seduta e schienale imbottiti con anima in legno multistrato marino curvato e poliuretano incastonati nel telaio metallico rivestiti in pelle o tessuto della selezione outdoor. Il telaio è disponibile nelle finiture metalliche lucide oppure nella versione heavy-duty verniciato a polveri (per esterni).

Chair in shiny tubular metal curved and welded in one piece. Padded seat and backrest with structure in curved marine plywood and polyurethane, surrounded by tubular metal frame and upholstered in outdoor leather or fabric. The frame can be finished with any lacquer of the shiny metal lacquer finish selection or in powder painting finishing.

vedi anche/see also ELEANOR sedia-chair

● click here



FARNESE

SEDIA, POLTRONCINA - CHAIR, ARMCHAIR
Samuele Mazza

Struttura portante realizzata in rattan naturale, legature in cuoio e fascette metalliche inox lucido con incisione stemma araldico Visionnaire. Piano di seduta in multistrato marino. Cuscino di seduta in poliuretano densità 30 kg/m3 FE elastico, con rinfascio in falda acrilica 350 gr e foderatura di cotone. Cuscino schienale in poliuretano densità 18 kg/m3 elastico, con rinfascio in falda acrilica 350 gr e foderatura di cotone. Elementi metallici decorativi tubolari disponibili nella selezione finiture metalliche, con logo Visionnaire. Rivestimento sfoderabile. Disponibile nella versione sedia e poltroncina. Sconsigliato l'uso in ambienti completamente esposti alle intemperie.

Main structure in natural rattan, bindings in cuoio leather and metal clips in shiny stainless steel with Visionnaire engraved coat of arms. Seat support in marine plywood. Seat cushion in polyurethane d. 30 kg/m3 FE elastic, with external acrylic layer 350 gr with cover in cotton. Shaped back cushion in polyurethane d. 18 kg/m3 elastic, with acrylic layer 350 gr and cover in cotton. Decorative metal elements available in any colour included in the metal finish selection, with Visionnaire logo. Removable cover. Available in the version chair and armchair. Not recommended for use in environments completely exposed to the elements.

● click here

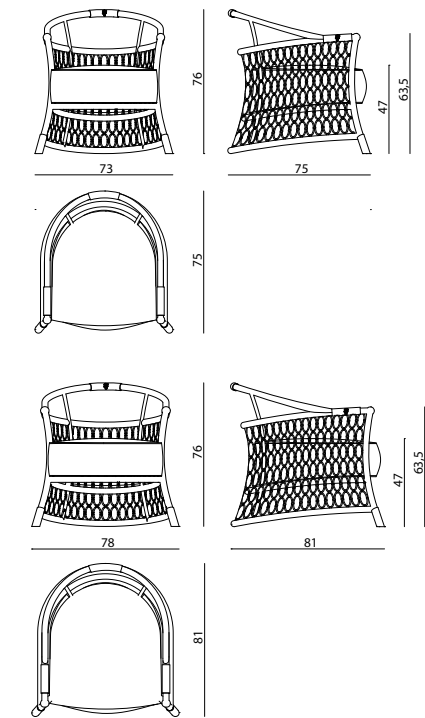



FREDDIE

PANCA OUTDOOR - OUTDOOR BENCH

Alessandro La Spada

Panca outdoor, struttura portante in acciaio inox 316 lucido con fondo curvo e gambe a colonna con superfici concave e convesse. Seduta con imbottitura drenante e rivestimenti per uso esterno.

Outdoor bench. Main structure in shiny 316 stainless steel with curved base and column-shaped legs designing concave and convex angles. Seat with self-draining padding and outdoor upholstery.

vedi anche/see also FREDDIE tavolo pranzo-dining table

● [click here](#)

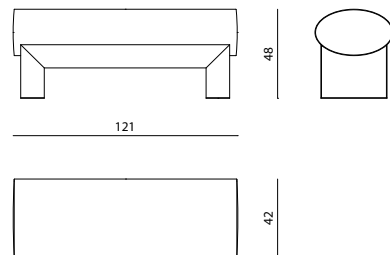

KYLO PADDED DEHORS

SEDIA OUTDOOR - OUTDOOR CHAIR

Alessandro La Spada

Scocca in legno multistrati marino curvato, con gambe in tubo metallico conificato e piedi torniti. Tappezzeria trapuntata con rivestimento in pelle o tessuto della selezione outdoor e filetti sul bordo schienale nello stesso materiale. Il telaio è disponibile verniciato a polveri (per esterni), i puntali in metallo sono disponibili nella selezione finiture metalliche satiniate.

External structure in curved marine plywood, with legs in conic metal tube and turned feet. Quilted upholstery in outdoor leather or fabric and matching pipings on the edges. Heavy-duty version: frame in powder painting, metal tips available in the satinized metal finishing selection.

vedi anche/see also KYLO PADDED sedia-chair

● [click here](#)

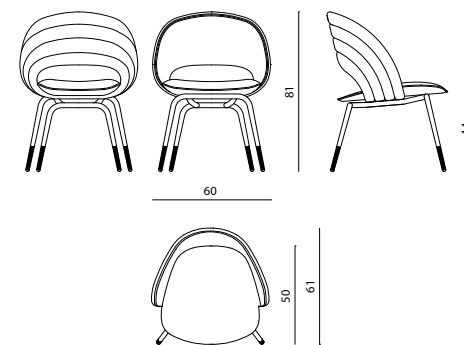

KYLO PADDED DEHORS

SGABELLO - STOOL

Alessandro La Spada

Scocca in legno multistrati marino curvato, con gambe in tubo metallico conificato e piedi torniti. Tappezzeria trapuntata con rivestimento in pelle o tessuto della selezione outdoor e filetti sul bordo schienale nello stesso materiale. Il telaio è disponibile verniciato a polveri (per esterni), i puntali in metallo sono disponibili nella selezione finiture metalliche satiniate.

External structure in curved marine plywood, with legs in conic metal tube and turned feet. Quilted upholstery in outdoor leather or fabric and matching pipings on the edges. Heavy-duty version: frame in powder painting, metal tips available in the satinized metal finishing selection.

vedi anche/see also KYLO PADDED sgabello-stool

● [click here](#)

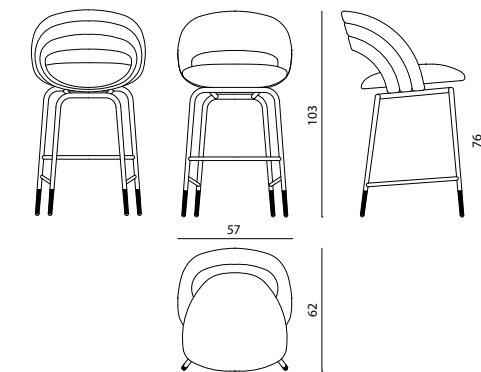



PANAREA

SEDIA REGAL - REGAL CHAIR
Alessandro la Spada

Struttura portante ad elementi conificati ricurvi in alluminio con corona tubolare di raccordo all'estremità dei coni. Placchette decorative ovali in ottone con stemma araldico Visionnaire. Piano di seduta in multistrato marino. Cuscino di seduta sagomato in poliuretano espanso con strato superiore in Memory Foam® con rinfascio in resinato. Interliner di cotone e fodera idrorepellente. Rivestimento sfoderabile. Le parti metalliche sono disponibili nella selezione finiture metalliche.

Main structure made of curved cone chromed steel with crown connecting in aluminium at the extremity of the cones. Decorative oval plates in brass with Visionnaire coat of arms. Sitting surface in marine plywood. Shaped seat cushion in polyurethane with upper layer in Memory Foam®; external cover in resin cotton. Interliner and waterproof lining. Metal parts can be lacquered in any colour of the metal finish selection.

● click here

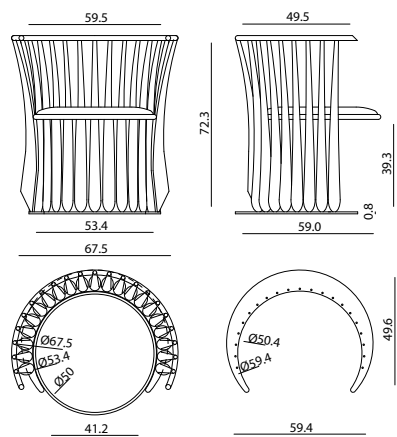

SUNNY DEHORS

POLTRONCINA - ARMCHAIR
Alessandro La Spada

Sedia imbottito con telaio in acciaio inox lucidato, struttura dello schienale curvato e del sedile in multistrati. Imbottitura in poliuretano a densità differenziate. Rivestimento in pelle o tessuto. Le parti in metallo sono disponibili nella selezione finiture metalliche.

Upholstered chair with frame in polished stainless steel, structure of the curved backrest and seat in plywood. Padding in polyurethane in different densities. Main upholstery in leather or fabric. Metal parts available in the metal finishing selection.

vedi anche/see also SUNNY sedia-chair

● click here

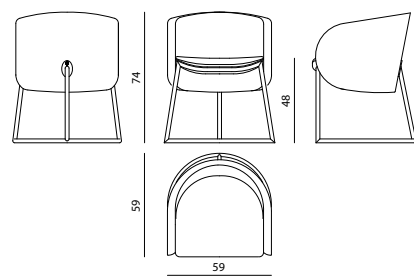

SUNNY DEHORS

SGABELLO - STOOL
Alessandro La Spada

Sgabello imbottito con telaio in acciaio inox lucidato, struttura dello schienale curvato e del sedile in multistrati. Imbottitura in poliuretano a densità differenziate. Rivestimento in pelle o tessuto. Le parti in metallo sono disponibili nella selezione finiture metalliche.

Upholstered stool with frame in polished stainless steel, structure of the curved backrest and seat in plywood. Padding in polyurethane in different densities. Main upholstery in leather or fabric. Metal parts available in the metal finishing selection.

vedi anche/see also SUNNY sgabello-stool

● click here

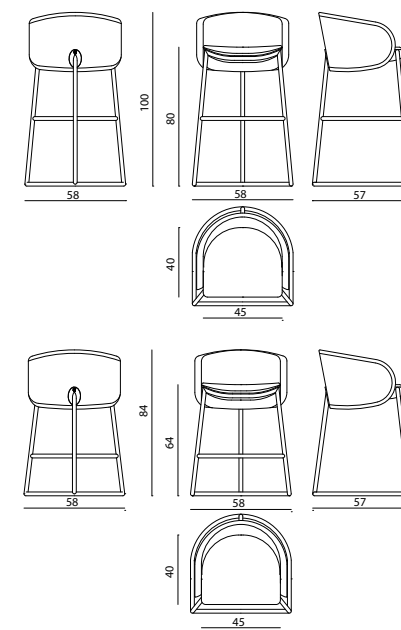

TANYA DEHORS

POLTRONCINA - ARMCHAIR
Roberto Lazzeroni

Sedia monoscocca in poliuretano stampato a freddo con scocca interna in metallo. Rivestimento in pelle o tessuto della selezione outdoor; la parte esterna può essere rivestita in contrasto con la parte interna, divisa da un filetto in pelle, tappezzeria rifinita sul retro con cucitura manuale. Gambe costituite da una singola struttura in fusione di alluminio, disponibile nella selezione vernici a polveri (per esterni) e piedini in acciaio inox, disponibili nella selezione finiture metalliche.

Chair in cold-cured PU Foam molding with internal metal shell. Upholstery in outdoor leather or fabric; the external part can be covered in contrast with the internal part, divided by a leather thread, upholstery finished on the back with manual stitching. Legs in aluminium cast, available in powder painting finishing and stainless steel feet, available in the metal finishing selection.

vedi anche/see also TANYA sedia-chair

● click here

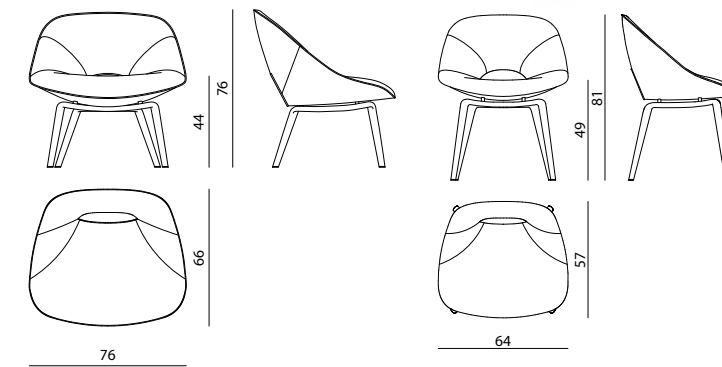



VANJA

POLTRONCINA - ARMCHAIR

Alessandro La Spada

 Sedia in metallo protetto da fondo zincante e vernice a polveri (per esterni). Schienale e sedile in multistrato curvo con imbottitura in poliuretano a densità differenziate rivestito in falda acrilica. Rivestimento disponibile in pelle o tessuto da esterni.

Chair in metal covered by a protective bottom plate, galvanized and lacquered in powder painting finishing. Backrest and seat in curved plywood with padding in polyurethane in different densities covered in acrylic fibre. Upholstery available in waterproof leather or fabric.

 click here

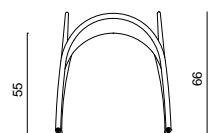
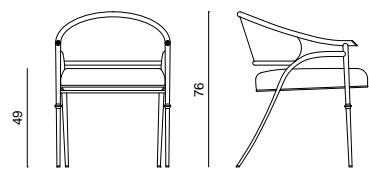



BREEZE OUTDOOR

TAVOLO BASSO, TAVOLINI - LOW TABLE, SMALL TABLE

Roberto Tapinassi - Maurizio Manzoni

Tavolino a tre piedi in legno di iroko massello, con fregi e piedini in ottone inciso satinato. Top in vetro stratificato double-face con stampa digitale e sfondo verde scuro e foglia oro o argento, retro nero. Gli accoppiamenti disponibili sono: libellula e foglia oro (top da Ø120 cm), coleottero nero e foglia oro, farfalla e foglia argento oppure Snake 3 e foglia argento (top da Ø60 cm), coleottero verde e foglia argento, colibri e foglia argento oppure Snake 2 e foglia argento (top da Ø50 cm), cervo volante e foglia argento, pesci lottatori e foglia oro oppure Snake 1 e foglia argento (top da Ø40 cm). Struttura disponibile nelle tonalità: iroko naturale, biscotto e testa di moro, a poro aperto. La parti metalliche sono disponibili nella selezione finiture metalliche satinato. Disponibile in opzione finitura poliestere lucida.

Three-foot table in iroko solid wood, with decorations and feet in satinized engraved brass. Top in double face laminated glass with digital print, dark green background and gold or silver leaf. The possible matchings are: dragonfly and gold leaf (top Ø120 cm); black beetle and gold leaf or butterfly and silver leaf, or Snake 3 and silver leaf (top Ø60 cm); green beetle and silver leaf or hummingbird and silver leaf, or Snake 2 and silver leaf (top Ø50 cm); stag beetle and silver leaf or Siamese fighter fishes and gold leaf, or Snake 1 and silver leaf (top Ø40 cm). Structure available in: natural iroko, biscuit and dark brown, mat open-pore finishing. Metal parts available in the satinized metal finishing selection. Available also in polished polyester finishing.

vedi anche/see also BREEZE INDOOR tavolo basso, tavolini-low table, small table

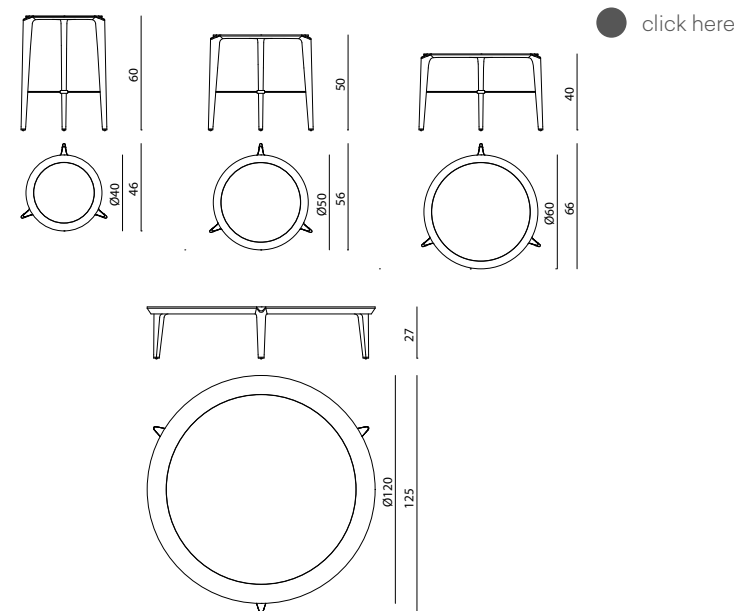

CONEY ISLAND

TAVOLO BASSO - LOW TABLE

Samuele Mazza

Tavolo basso tondo in rattan sintetico intrecciato a mano con trama "paglia di Vienna" su telaio in traliccio di alluminio. Top in marmo. Il rattan sintetico è disponibile nei colori white gold, honey gold e bronze.

Round low table in hand-woven synthetic rattan, giving a "Vienna straw" pattern effect, frame in aluminium truss. Top in marble. Synthetic rattan is available in white gold, honey gold and bronze.

● click here

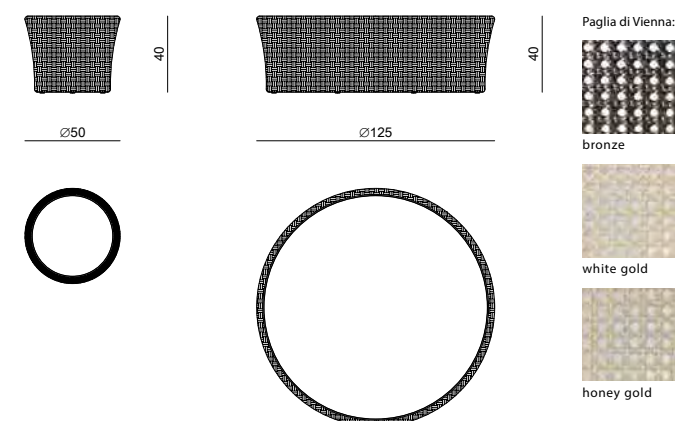

CYCAS

TAVOLO BASSO - LOW TABLE

Alessandro La Spada - Samuele Mazza

Telaio in tubo acciaio inox lucido, gambe in acciaio e ottone con tornerie in alluminio. Top ad incasso in marmo. Le parti metalliche sono disponibili nella selezione finiture metalliche lucide.

Frame in shiny stainless steel tube, legs in steel and brass with aluminium turnings. Built-in top in marble. Metal parts available in the polished metal finishing selection.

● click here

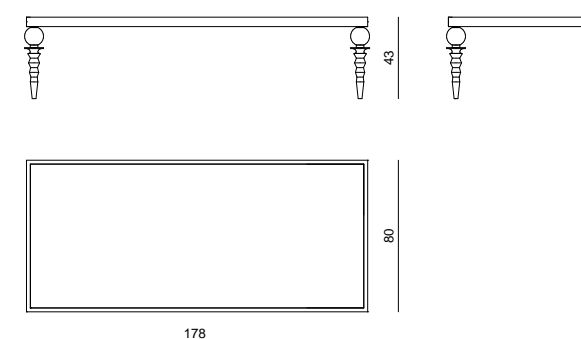

DYLAN 2022

TAVOLO DA PRANZO - DINING TABLE

Alessandro La Spada

Struttura in acciaio AISI 316, crociera e zavorra in ghisa verniciata a polvere. Gamba centrale in ottone rigato verniciato a polvere e anello decorativo in ottone cromato. Base in acciaio AISI 316 spazzolato. Top in vetro satinato sp. 8 mm, stratificato con stampa digitale sulla superficie, molato a filo lucido incollato su sotto-top in HPL. Cornice perimetrale in acciaio verniciato a polvere. Le parti metalliche sono disponibili verniciate a polveri (per esterni).

Frame in AISI 316 steel, powder-coated cast iron cross and ballast. Striped powder-coated brass central leg and chrome-plated brass decorative ring. Brushed AISI 316 steel base. 8 mm thick satin-finish glass top, laminated with digital printing on the surface, ground to a polished edge glued onto HPL sub-top. Perimeter frame in powder-coated steel. Metal parts are available powder-coated (for outdoor use).

● click here

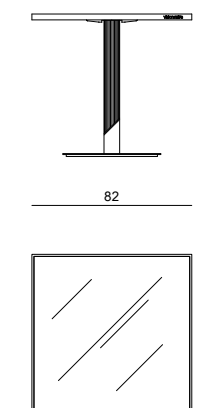



FARNESE

TAVOLO BASSO - LOW TABLE
Samuele Mazza

Struttura portante realizzata in rattan naturale, legature in cuoio. Top superiore ed inferiore in granito. Elementi metallici decorativi tubolari disponibili nella selezione finiture metalliche. Sconsigliato l'uso in ambienti completamente esposti alle intemperie.

Main structure made in natural wicker, belts in leather. Upper and lower top in granite. Decorative tubular metal elements can be lacquered in any colour of the metal finish selection. The use in locations entirely exposed to the weather is not recommended.

vedi anche/see also FARNESE poltrona-armchair, FARNESE lettino-daybed, FARNESE sedia-chair

● click here

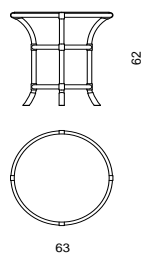

GALLOWAY

TAVOLO BASSO - LOW TABLE
Roberto Tapinassi - Maurizio Manzoni

Tavolo basso in legno di iroko massello e top in marmo. Piedini in acciaio inox. Ripiano portariviste in vetro fumè. Le parti in metallo sono disponibili nella selezione finiture metalliche.

Low table in iroko solid wood and top in marble. Feet in stainless steel. Magazine-holder shelf in smoked mirror. Metal parts can be lacquered in any colour included in the metal finish selection.

vedi anche/see also GALLOWAY divano, poltrona-sofa, armchair

● click here

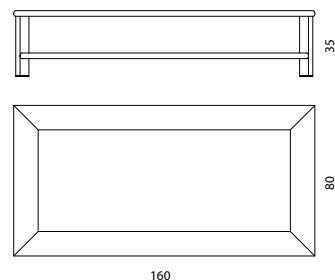

FREDDIE

TAVOLO DA PRANZO OUTDOOR - OUTDOOR DINING TABLE
Alessandro La Spada

Tavolo da pranzo outdoor, struttura portante in acciaio inox 316 lucido con sotto-top curvo e gambe a colonna con superfici concave e convesse. Top in granito oppure in lastra di cemento ad alta densità UHPC/Ductal decorata con scaglie di ottone annegate in pasta. Fregi decorativi a filo top in acciaio inox 316 solo sulla versione con top in cemento.

Outdoor dining table. Main structure in polished 316 stainless steel with curved under-top and column-shaped legs designing concave and convex angles. Top in granite or in slab of UH PC/DUCT AL concrete decorated with brass particles. Top decorated with metal inserts in 316 stainless steel only on version with concrete top.

vedi anche/see also FREDDIE panca outdoor-bench outdoor

● click here

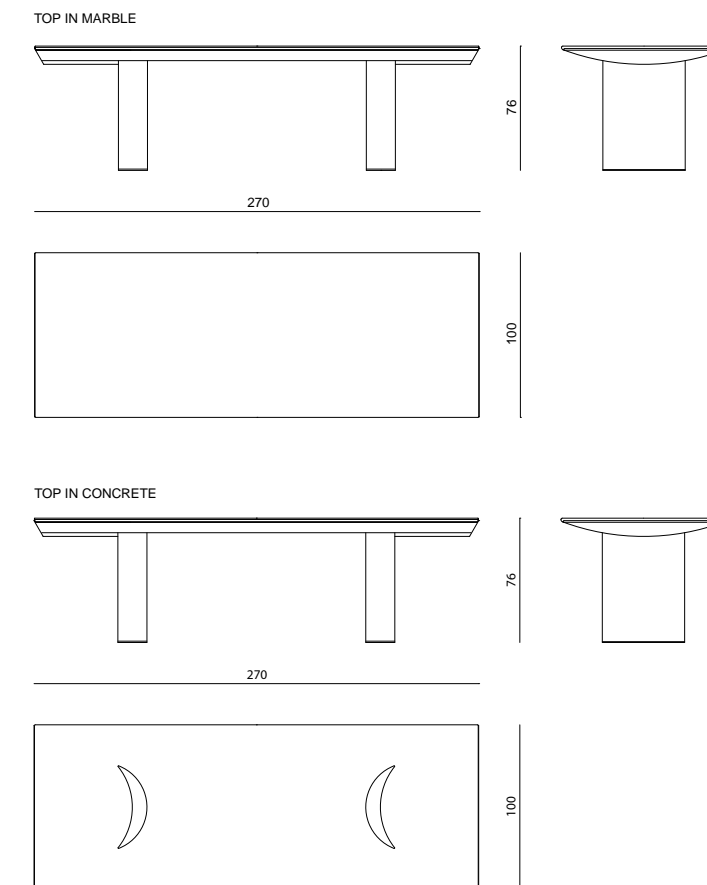



GORGONA

TAVOLO BASSO - LOW TABLE

Alessandro la Spada

Struttura in resina poliuretanic rigida, con base/zavorra in legno massello. Laccatura catalitica, finitura semi lucida.

Structure in rigid polyurethane resin with base in solid wood. Catalytic lacquered, half-glossy finishing.

● [click here](#)

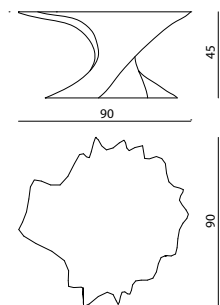

MERLINO DEHORS

TAVOLO DA PRANZO - DINING TABLE

Alessandro la Spada - Samuele Mazza

Telaio in acciaio AISI 316 40x10 mm con top in vetro temperato laccato a incasso. Gambe in acciaio inox lucido 40x40 mm, disponibili nella selezione finiture metalliche. Disponibile anche in versione con parti metalliche verniciate a polveri.

Frame in polished AISI 316 stainless steel 40x10 mm with recessed tempered glass 10 mm lacquered top. Legs in polished stainless steel 40x40 mm, available in the metal finishing selection. Also available in a version with powder-coated metal parts.

● [click here](#)

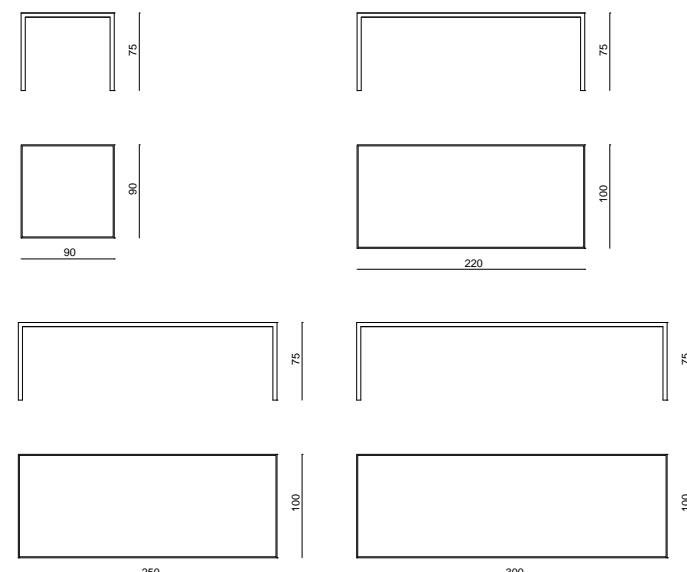

OBERTO

TAVOLO BASSO - LOW TABLE

Samuele Mazza

Struttura portante realizzata in manao scortecciato e laccato con legature in cuoio e fascette metalliche finitura inox lucido con incisione stemma araldico Visionnaire. Top in marmo o in vetro retro laccato. Sconsigliato l'uso in ambienti completamente esposti alle intemperie.

Main structure made in stripped and lacquered manao wood with bindings in cuoio leather and metal clips finitura inox lucido with Visionnaire engraved coat of arms. Top in marble or in back-lacquered glass. Not recommended for use in environments completely exposed to the elements.

● [click here](#)

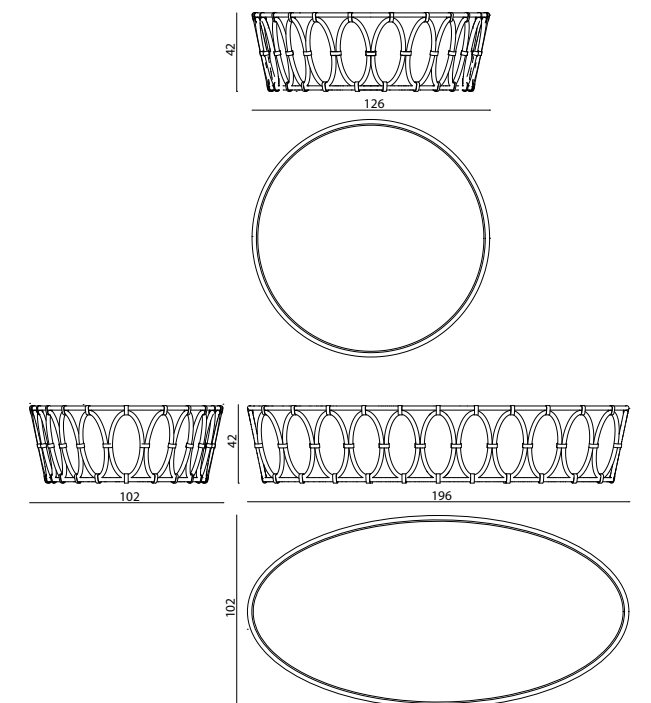



PALM BEACH

TAVOLO BASSO - LOW TABLE

La Conca

Tavolo basso in rattan sintetico intrecciato a mano, struttura portante in traliccio di alluminio, top parte in marmo ad incasso e parte con pouf in poliuretano da esterni a doppia densità e falda acrilica, rivestito in tessuti outdoor. Piedi in acciaio inox AISI 316 lavorato al laser. Il rattan sintetico è disponibile nei colori white gold, honey gold e bronze.

Low table in hand-woven synthetic rattan, main structure in aluminium truss, small built-in top in marble and pouffe in polyurethane (suitable for outdoor) in double densities and acrylic fibre. Upholstery in leather or fabric. Feet in laser-cut stainless steel AISI 316 available in chrome, gold, champagne, bronze, Siena, black nickel and gunmetal finishing. Synthetic rattan is available in white gold, honey gold and bronze.

vedi anche/see also PALM BEACH divano-sofa, chaise-longue

● click here

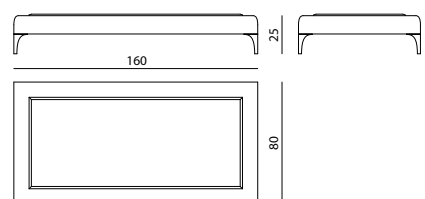
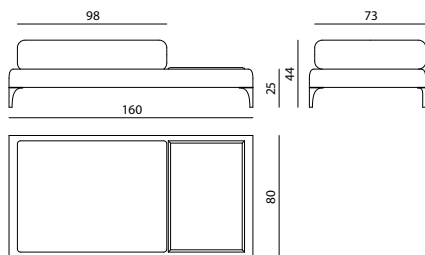

REDDING

TAVOLO BASSO - LOW TABLE

Alessandro La Spada

Tavolino da outdoor in mogano, disponibile in finitura lucida o opaca. La struttura è ottenuta per scolpitura di elementi in massello di mogano arrotondati e lavorati, con piedini in acciaio inox AISI 316 conico e lucidato. Il top in quarzite Patagonia è semi-incassato e lavorato con bordo smussato. Le parti in metallo sono disponibili verniciate a polveri (per esterni) o nella selezione finiture metalliche lucide.

Outdoor table in mahogany, available with polish or mat finish. Structure obtained by carving solid mahogany blocks, then rounded and finished. Feet and wheels in polish AISI 316 stainless steel with conic shape. The top in Patagonia quartz is semi-recessed and finished with a bevelled edge. Metal parts available with any of the powder coating in the outdoor metal finish selection or in any lacquer of the polish metal finish selection.

vedi anche/see also REDDING lettino-daybed

● click here

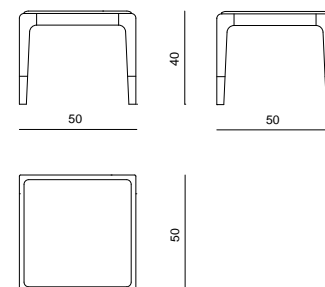

PANAREA

TAVOLO DA PRANZO - DINING TABLE

Alessandro La Spada

Struttura portante ad elementi conificati ricurvi, in alluminio con corona ellittica inferiore di raccordo. Top in marmo spessore 20 mm, sotto-top in piastra di alluminio. Le parti metalliche sono disponibili nella selezione finiture metalliche.

Main structure made of curved cone chromed steel in aluminium with lower elliptical connection ring. Top in marble th. 20 mm, undertop in aluminium plate. Metal parts can be lacquered in any colour of the metal finish selection.

● click here

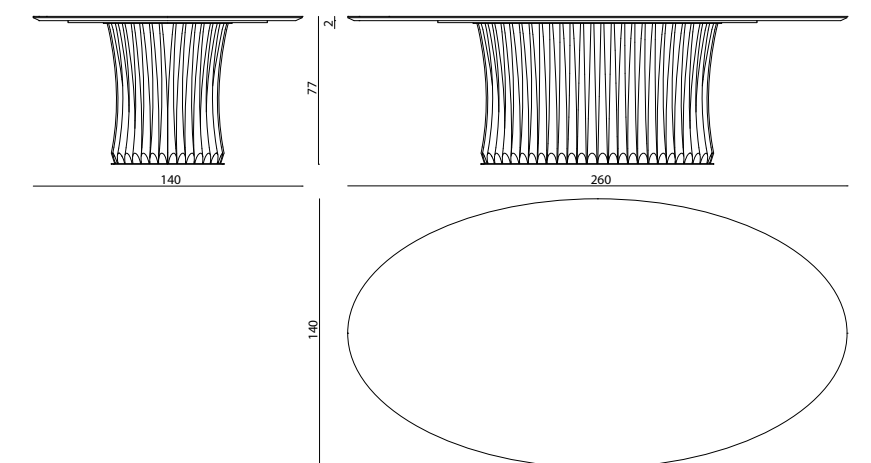



PERGAMO

TAVOLO DA PRANZO - DINING TABLE

Samuele Mazza

Tavolo in marmo Bianco Carrara a pianta ottagonale con cornice a greca in marmo Grigio Bardiglio su bordo in marmo Nero Africa. Gambe in marmo Bianco Carrara. Barra orizzontale di collegamento in alluminio lucidato, piastre e contropiastre in acciaio lucido con logo. Le parti in metallo sono disponibili nella selezione finiture metalliche.

Marble table in White Carrara. Profile in marble Black Africa decorated with greek motive in marble Grey Bardiglio. Legs in marble White Carrara. Horizontal bar in polished aluminium, plates and counter-plates in polished steel with logo. Metal parts can be lacquered in any colour included in the metal finish selection.

● [click here](#)

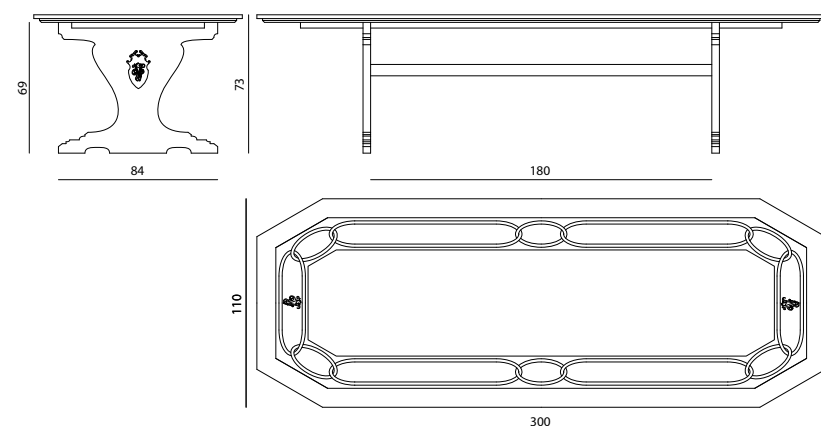

SOLSTICE

TAVOLO PRANZO - DINING TABLE

Alessandro La Spada

Struttura a gabbia su base ellittica o circolare in acciaio inox taglio laser. Base e top in acciaio inox piatto, montanti sagomati a scafo di nave in acciaio inox piatto. Top in vetro extrachiario spess. mm 15 temperato. Le parti metalliche sono disponibili nella selezione finiture metalliche.

Cage structure on elliptic or circular base in laser cut stainless steel. Base and top in flat stainless steel, bars shaped as boat hull in flat stainless steel. Top in extraclear tempered glass th. mm 15. Metal parts can be lacquered in any colour of the metal finish selection.

vedi anche/see also SOLSTICE tavolo da pranzo-dining table, SOLSTICE tavolo basso-low table

● [click here](#)

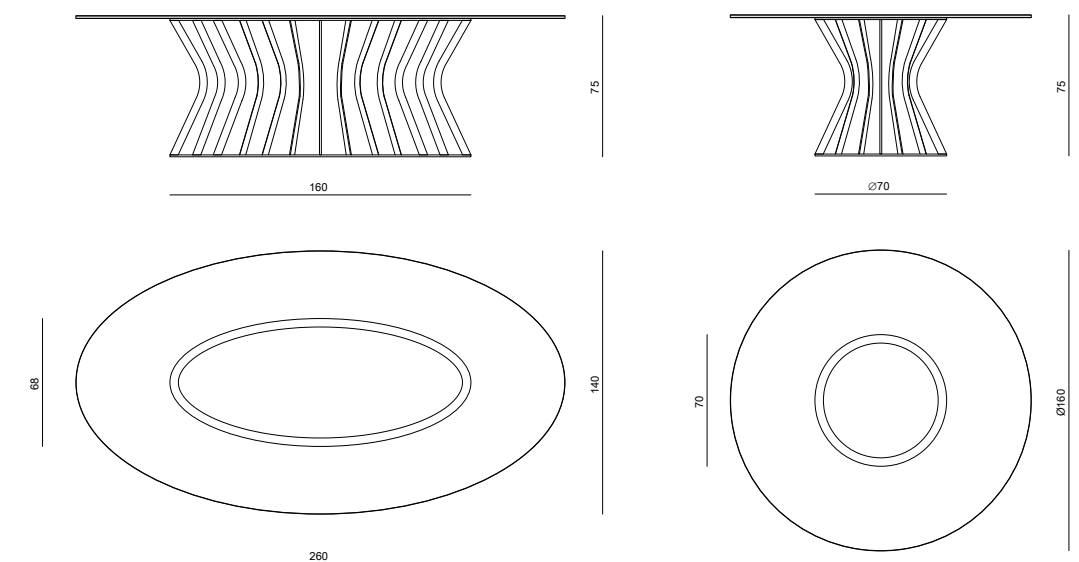



STANKAR

TAVOLO BASSO - LOW TABLE

La Conca

Tavolo basso con struttura metallica zincata e verniciata a polveri, intrecciata con corda in canapa naturale e fili in lurex oro e argento. Top in pietra lavica smaltata a fuoco colore antracite.

Outdoor low table, frame in lacquered and galvanised metal interwoven with hempen rope and lurex threads. Top in enamelled lava stone, anthracite colour.

vedi anche/see also STANKAR divano, poltrona, poltrona a dondolo - sofa, armchair, rocking armchair

● click here

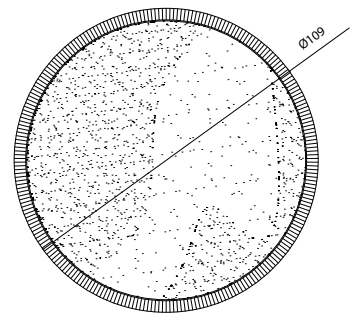
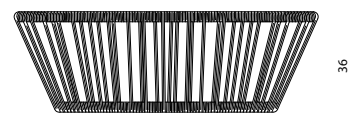

VIENNA

TAVOLO BASSO - LOW TABLE

m2atelier

Tavolino in marmo Carrara e telaio asimmetrico in massello di iroko, con un lato in paglia di Vienna naturale, entrambi trattati con finitura per esterni opaca. Accostando due tavolini si ottiene una composizione a formare un unico piano in marmo da 120 cm.

Table in Carrara marble and asymmetric structure in solid wood, with one side in natural Wien straw, both treated with mat outdoor finish. Juxtaposing 2 tables it is possible to obtain a unique countertop in marble, 120 cm in size.

● click here

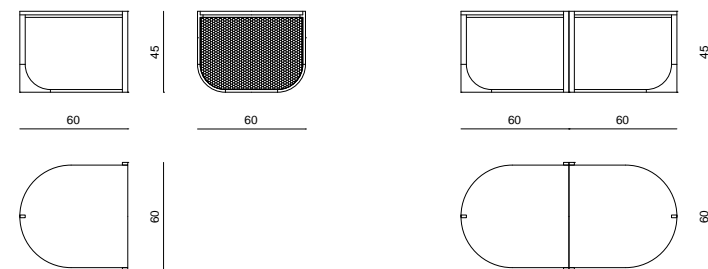

WING

TAVOLO DA PRANZO - DINING TABLE

m2atelier

Tavolo tondo da outdoor e indoor. Top ad anello in legno multistrati fenolico rivestito in iroko, bordato con profilo in alluminio bombato e decorato con fibbie in ottone massiccio, disponibile nella selezione finiture metalliche lucide. Basamento composto da gambe in fusione di alluminio da esterni completate da un vaso in marmo Carrara scolpito e lucidato a mano. Vaso interno in materiale sintetico adatto al contenimento di piante e fiori in terra. I profili e le gambe metalliche sono disponibili verniciate a polveri (per esterni). Le parti in legno sono protette con vernici isolanti per esterni con finitura opaca. Peso: Ø200 cm 210 kg, Ø180 cm 200 kg, Ø160 cm 195 kg.

Round table for indoor and outdoor use. Top and ring in phenolic boards covered with iroko veneer. Profile in bulding aluminium and decorative buckles in solid brass, available in any lacquer of the polish metal finish selection. Base consisting of legs in aluminium cast suitable for outdoor use, provided with a vase in hand sculpted and polished Carrara marble. Internal pot in syntehtic materials suitable for containing plants and flowers. Legs available in any of the powder coating in the outdoor metal finish selection. Solid wood parts are finished with a mat isolating lacquer suitable for outdoor products. Weight Ø200 cm 210 kg, Ø180 cm 200 kg, Ø160 195 kg.

vedi anche/see also WING divano-sofa

● click here

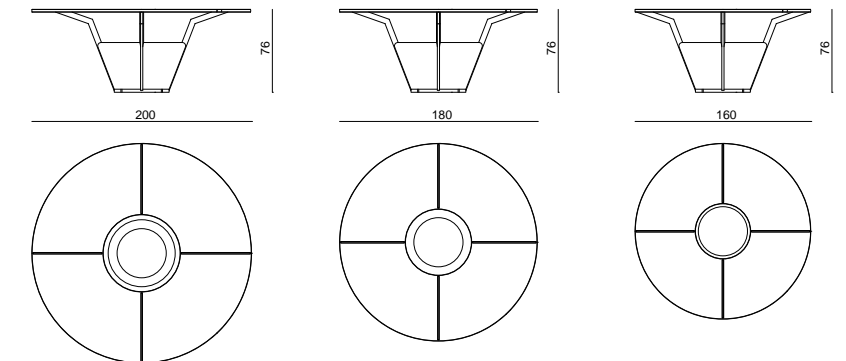



APPLE

LAMPADA DA TERRA - FLOOR LAMP
m2atelier

Lampada da terra da esterno a LED, struttura principale in acciaio inox satinato con base in marmo Travertino, Botticino o Carrara. Il diffusore in metallo e policarbonato è orientabile tramite una maniglia rivestita in cordino di pelle. LED dimmerabile attraverso il comando on/off/dimmer sulla base. Grado di protezione IP44.

Outdoor floor lamp with LED light. Main structure in satin stainless steel with marble base in Travertine, Botticino or Carrara. The orientation of the diffuser in metal and polycarbonate can be adjusted by means of a handle covered in leather rope. LED dimmable light can be controlled by an on/off/dimmer switcher positioned on the base. IP44 protection rating.

● click here

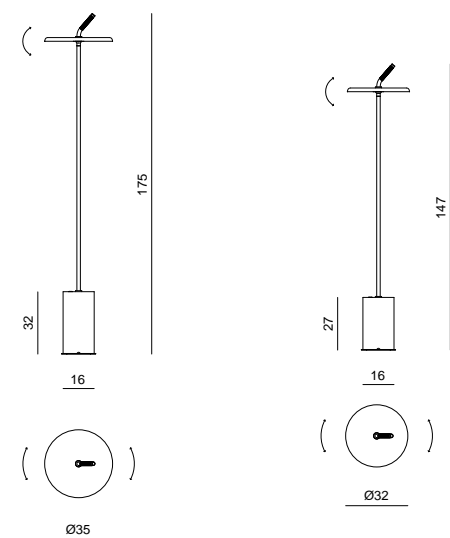

CALLIA DEHORS

APPLIQUE - WALL LAMP
Alessandro La Spada



Lampada in acciaio inox con paralume a forma di foglia, ottenuta da una sottile lamina deformata a freddo, con superficie lucida a effetto "metallo liquido", internamente satinata con superficie anti-abbagliamento. Stelo centrale con sorgente luminosa a LED DS da 4,5W con diffusore in pirex satinato a tenuta stagna. Elemento decorativo in marmo. Le parti metalliche sono disponibili nella selezione finiture metalliche. Peso: 8 Kg (versione Big), 5 kg (versione Mini). Grado di protezione IP44. Questo modello monta sorgenti luminose a LED a lunga durata integrate nella struttura della lampada, non sostituibili dall'utente. Sconsigliato l'uso in ambienti completamente esposti alle intemperie.

Disponibile anche in versione indoor.

Lamp in stainless steel with leaf-shaped diffuser, obtained from a thin cold-finished layer, with shiny surface with "liquid metal" effect, internally satin with anti-glare surface. Central stem with water-tight diffuser in satin pyrex, LED DS light with 4,5W power. Decorative element in marble. Metal parts can be lacquered in any colour included in the metal finish selection. Weight: 8 kg (Big version), 5 kg (Mini version). IP44 protection rating. This model is equipped with long-life LED light sources integrated into the lamp structure, which can not be replaced by the user. The use in locations entirely exposed to the weather is not recommended.

Available also in indoor version.

vedi anche/see also CALLIA lampada da tavolo-table lamp, CALLIA piantana-floor lamp

● click here

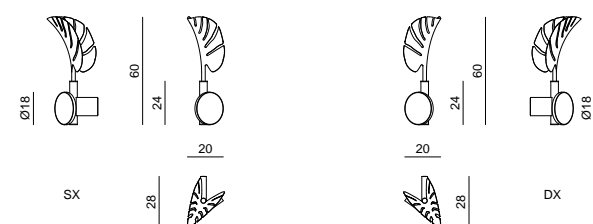

CALLIA DEHORS

PIANTANA - FLOOR LAMP
Alessandro La Spada



Lampada in acciaio inox con paralume a forma di foglia, ottenuta da una sottile lamina deformata a freddo, con superficie lucida a effetto "metallo liquido", internamente satinata con superficie anti-abbagliamento. Tre sorgenti luminose G9 con diffusore in pirex satinato a tenuta stagna, massimo assorbimento 40W, oppure a luci LED max 10W. Elementi decorativi in marmo. Le parti metalliche sono disponibili nella selezione finiture metalliche. Sconsigliato l'uso in ambienti completamente esposti alle intemperie.

Lamp in stainless steel with leaf-shaped diffuser, obtained from a thin cold-finished layer, with shiny surface with "liquid metal" effect, internally satin with anti-glare surface. 3 lights with water-tight diffuser in satin pyrex, G9 40 W max or LED 10W max power. Decorative elements in marble. The metal parts are available in the metal finishes selection. The use in locations entirely exposed to the weather is not recommended.

vedi anche/see also CALLIA lampada da tavolo-table lamp, CALLIA piantana-floor lamp

● click here

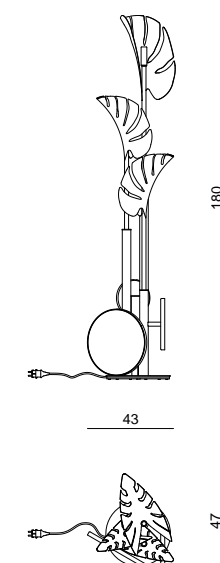

KATHRYN OUTDOOR

LAMPADA DA TERRA OUTDOOR - OUTDOOR FLOOR LAMP
Giuseppe Viganò



Lampada da terra outdoor, struttura in multistrati marino curvato rivestito teak contenente una sfera luminosa in polietilene con grado di isolamento IP55, portalampada E27 max 25W, cavo di alimentazione con spina isolata SENZA interruttore.

Outdoor floor lamp, structure in curved marine plywood covered in teak containing a luminous sphere in polyethylene with IP55 insulation degree, E27 lampholder max 25W, power cord with insulated plug WITHOUT switch.

● click here

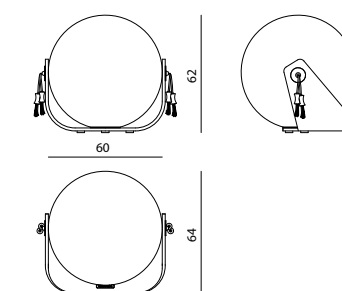



POLARIS

APPLIQUE OUTDOOR - OUTDOOR WALL LAMP

Alessandro La Spada

Lampada da parete composta da un elemento curvo in alluminio lucidato nella parte esterna e satinato nella parte interna, con diffusore in marmo retroilluminato con lavorazione del bordo a "spacco vivo". Le parti metalliche sono disponibili nella selezione finiture metalliche. Assorbimento max 30W, peso versione small 3 kg - potenza complessiva 3W, peso versione big 7 kg. Sconsigliato l'uso in ambienti completamente esposti alle intemperie.

Disponibile anche in versione indoor.

Wall lamp made of a curved element made of polished aluminium on the outside and satin-finished aluminium on the inside, with a backlit marble diffuser with 'rough-split' edge processing. The metal parts are available in the metal finish selection. Max. power consumption 30W, weight small version 3 kg - total power 3W, weight big version 7 kg. The use in locations entirely exposed to the weather is not recommended.

Available also in indoor version.

vedi anche/see also POLARIS lampada da tavolo-table lamp, applique-wall lamp, lampada da tavolo-table lamp, abat-jour, lampadario-chandelier

● click here



PANAREA

CACHE-POT ALTO E BASSO - HIGH AND LOW CACHE-POT

Alessandro La Spada

Struttura portante ad elementi conificati ricurvi, in alluminio con corona di raccordo. Vaso in ceramica finitura smaltata lucida con stemma araldico Visionnaire dorato. Le parti metalliche sono disponibili nella selezione finiture metalliche.

Main structure made of curved cone chromed steel with crown connecting in aluminium. Vase in shiny enamelled finishing with golden Visionnaire coat of arms. Metal parts can be lacquered in any colour of the metal finish selection.

● click here



ERCOLANO

TAPPETO DA ESTERNO - OUTDOOR CARPET

La Conca

Tappeto taftato a mano in polipropilene. Backing in cotone.

Hand-tufted carpet in polypropylene. Cotton backing.

● click here

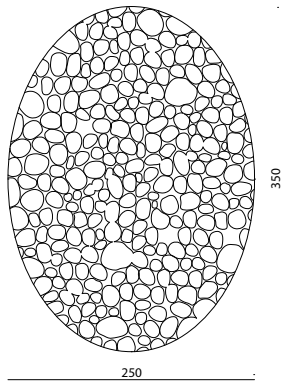

POMPEI

TAPPETO DA ESTERNO - OUTDOOR CARPET

La Conca

Tappeto taftato a mano in polipropilene con lavorazione carving manuale lungo il disegno. Backing in cotone.

Hand-tufted carpet in polypropylene with carving work. Cotton backing.

● click here

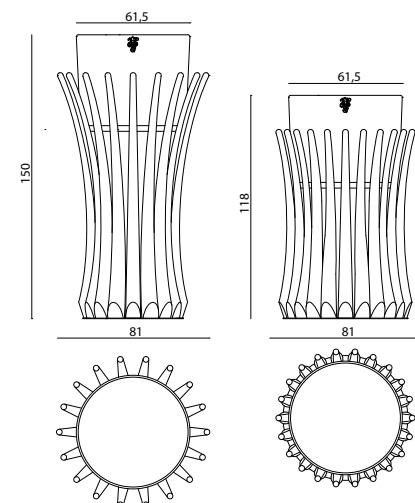
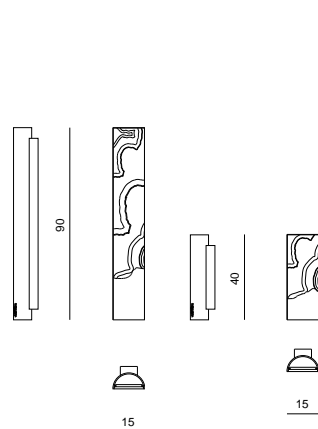
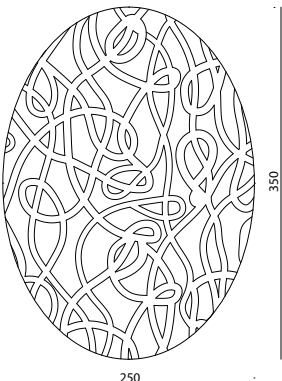

- click on the icons -



MERCURY ANNIVERSARY p.566



MERCURY ANNIVERSARY p.567



MERCURY ANNIVERSARY

DIVANO - SOFA

Rito Valla

Divano tappezzato in tessuto elastico. Struttura portante in legno massello e compensato. Molleggio seduta a nastri elastici. Imbottitura in poliuretani a densità differenziate e falda acrilica. Due basamenti costituiti da una stella a cinque razze in acciaio nero e piedi in legno massello dotati di piedini in ottone, disponibili nella selezione finiture metalliche.

Sofa upholstered in elastic fabric. Main structure in solid wood and plywood. Seat equipped with elastic spring belts. Padding in polyurethane foams with different densities and acrylic fiber. The two bases consist of a five spokes star in black steel and feet in solid wood with tips in brass, lacquered in any colour of the polish metal finish selection.

Edizione Anniversary limitata 60+15 pezzi.
Anniversary Limited edition 60+15 pieces

● [click here](#)

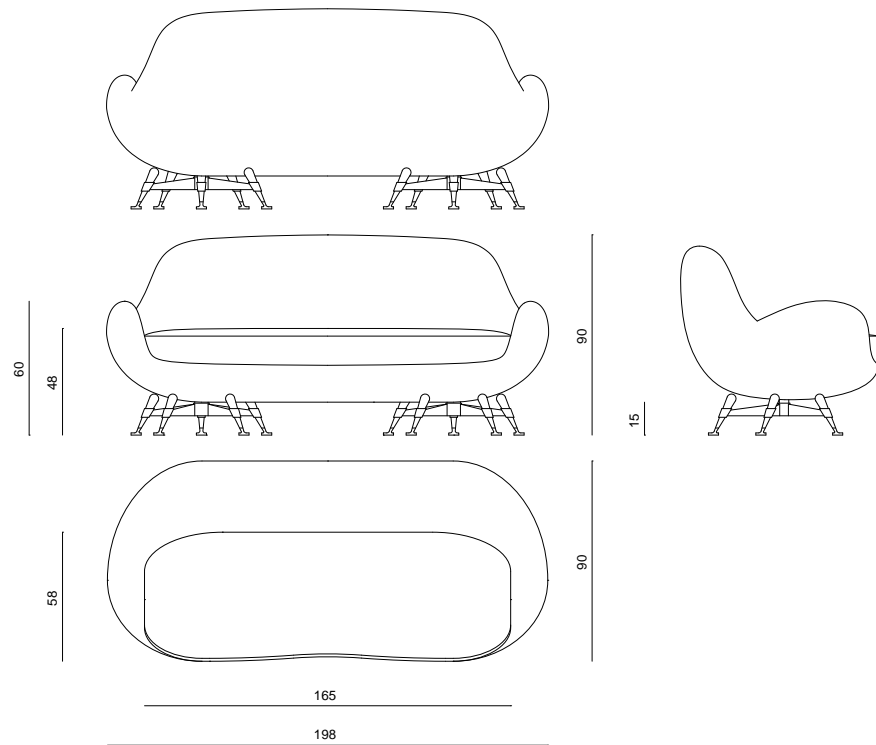

MERCURY ANNIVERSARY

POLTRONCINA - ARMCHAIR

Rito Valla

Poltroncina tappezzata in tessuto elastico. Struttura portante in legno massello e compensato. Molleggio seduta a nastri elastici. Imbottitura in poliuretani a densità differenziate e falda acrilica. Basamento costituito da una stella a cinque razze in acciaio nero e piedi in legno massello dotati di piedini in ottone, disponibili nella selezione finiture metalliche.

Armchair upholstered in elastic fabric. Main structure in solid wood and plywood. Seat equipped with elastic spring belts. Padding in polyurethane foams with different densities and acrylic fiber. The base consists of a five spokes star in black steel and feet in solid wood with tips in brass lacquered in any colour of the polish metal finish selection.

Edizione Anniversary limitata 60+15 pezzi.
Anniversary Limited edition 60+15 pieces

● [click here](#)

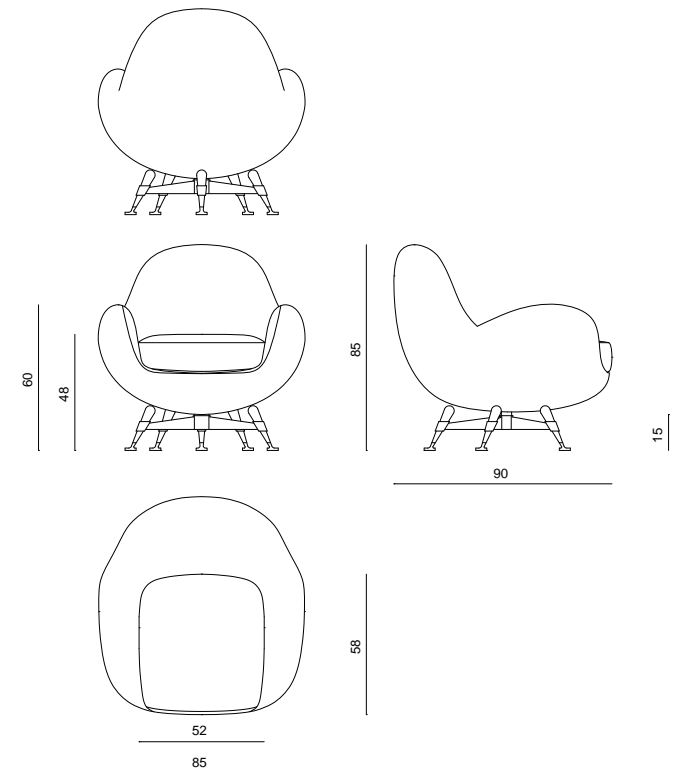

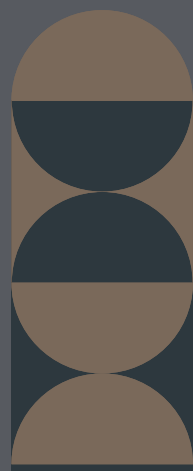

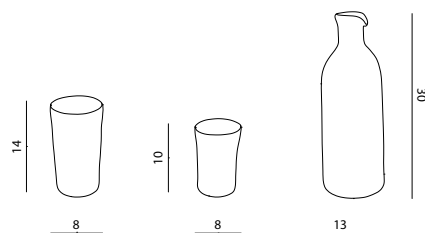

BALLET JOSEF

BOTTIGLIA E BICCHIERI - BOTTLE AND GLASSES
Marta Giardini

Collezione di bicchieri e bottiglie, soffiati a bocca e lavorati artigianalmente utilizzando le tecniche più raffinate della lavorazione del vetro di Murano. I colori minerali sono arricchiti con foglia d'argento o tramite la finitura 'rigadin'.

A collection of glasses and bottles designed by Marta Giardini, in blown glass crafted by hand using the most refined glassmaking techniques of Murano. The mineral colors are enhanced by silver leaf or a rigadin finish.

[click here](#)

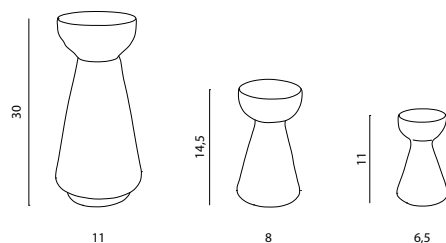

BALLET MARCEL

BOTTIGLIA E BICCHIERI - BOTTLE AND GLASSES
Marta Giardini

Collezione di bicchieri e bottiglie, soffiati a bocca e lavorati artigianalmente utilizzando le tecniche più raffinate della lavorazione del vetro di Murano. I colori minerali sono arricchiti con foglia d'argento o tramite la finitura 'rigadin'.

A collection of glasses and bottles designed by Marta Giardini, in blown glass crafted by hand using the most refined glassmaking techniques of Murano. The mineral colors are enhanced by silver leaf or a rigadin finish.

[click here](#)

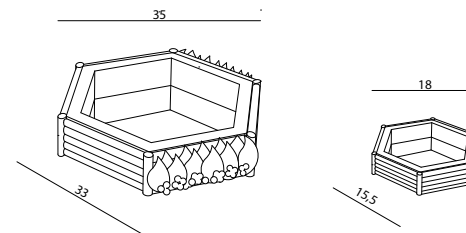

BAMBOO

VASSOI - TRAYS
Zanellato/Bortotto

Vassoi in legno laccato con applicazioni di specchi argentati a mano, foglie e canne di vetro realizzate secondo la tradizione Muranese.

Trays in lacquered wood with application of handmade silver mirrors and leaves of glass made with the traditional methods of Murano.

[click here](#)

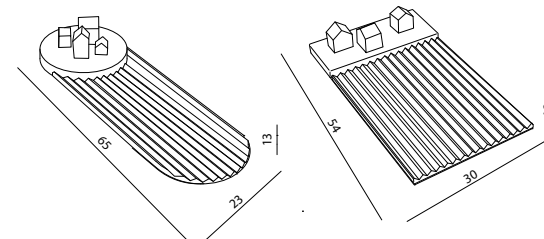
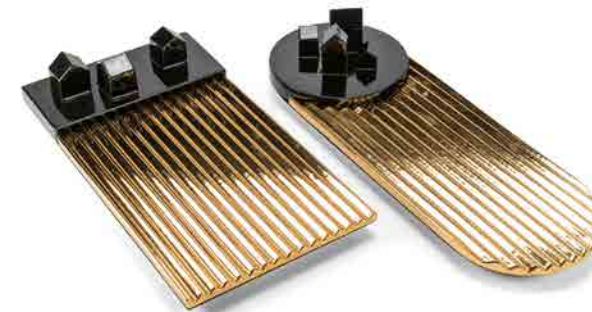

CASALE

VASSOIO - TRAY
Fausto Salvi

Vassoio realizzato a mano tramite unione di due parti in ceramica smaltata, con oro a terzo fuoco e un supporto in legno multistrato verniciato cerato. Ogni opera è da considerarsi "pezzo unico".

Hand-made tray made by assembling three parts: two in glazed ceramic, with gold, third fired and a support in painted waxed plywood. Each item should be considered a "one-of-a-kind" creation.

[click here](#)

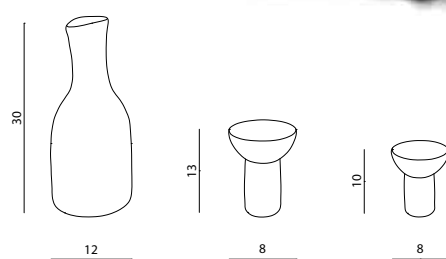

BALLET OSKAR

BOTTIGLIA E BICCHIERI - BOTTLE AND GLASSES
Marta Giardini

Collezione di bicchieri e bottiglie, soffiati a bocca e lavorati artigianalmente utilizzando le tecniche più raffinate della lavorazione del vetro di Murano. I colori minerali sono arricchiti con foglia d'argento o tramite la finitura 'rigadin'.

A collection of glasses and bottles designed by Marta Giardini, in blown glass crafted by hand using the most refined glassmaking techniques of Murano. The mineral colors are enhanced by silver leaf or a rigadin finish.

[click here](#)

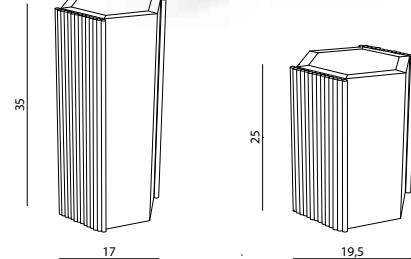

BAMBOO

VASI - VASES
Zanellato/Bortotto

Vasi in legno laccato con applicazioni di specchi argentati a mano, foglie e canne di vetro realizzate secondo la tradizione Muranese.

Vases in lacquered wood with application of handmade silver mirrors and leaves of glass made with the traditional methods of Murano.

[click here](#)

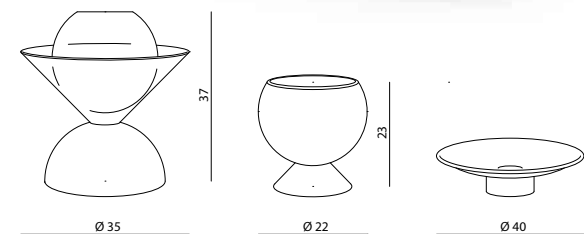

EQUILIBRI CIPRIA

VASI - VASES
Zanellato/Bortotto

Vasi e vassoi scultura composti da elementi di forme e colori diversi, realizzati artigianalmente in vetro di Murano.

Sculptural vases and trays composed of three parts with different forms and colors, crafted by hand in Murano glass.

[click here](#)

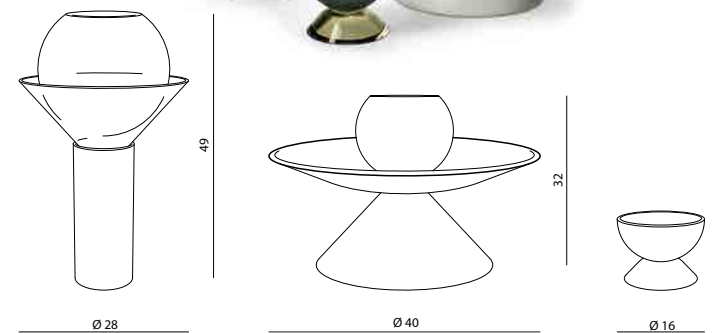

EQUILIBRI FUMÉ

VASI - VASES
Zanellato/Bortotto

Vasi e vassoi scultura composti da elementi di forme e colori diversi, realizzati artigianalmente in vetro di Murano.

Sculptural vases and trays composed of three parts with different forms and colors, crafted by hand in Murano glass.

[click here](#)

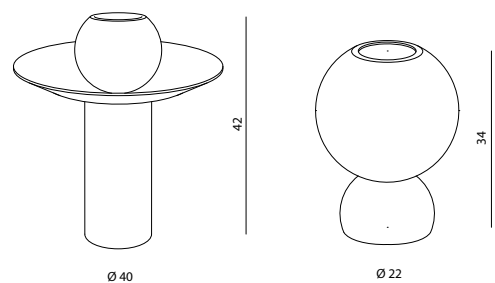

EQUILIBRI VERDE

VASI - VASES
Zanellato/Bortotto

Vasi e vassoi scultura composti da elementi di forme e colori diversi, realizzati artigianalmente in vetro di Murano.

Sculptural vases and trays composed of three parts with different forms and colors, crafted by hand in Murano glass.

[click here](#)

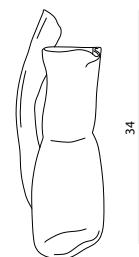

FABULA ARIONE

CARAFFA - CARAFE
Marta Giardini

Caraffa realizzata in prezioso vetro di Murano dalle tinte intense, soffiati a bocca e lavorati a mano libera.

Carafe made in precious Murano glass with intense hues, all the pieces are blown and crafted by hand.

[click here](#)

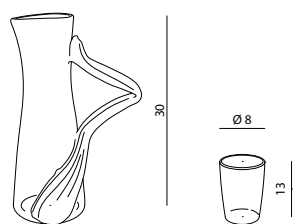

FABULA ANUBI

CARAFFA E BICCHIERI - CARAFE AND GLASSES
Marta Giardini

Caraffa e bicchieri realizzati in prezioso vetro di Murano dalle tinte intense, soffiati a bocca e lavorati a mano libera.

Carafe and glasses made in precious Murano glass with intense hues, all the pieces are blown and crafted by hand.

[click here](#)

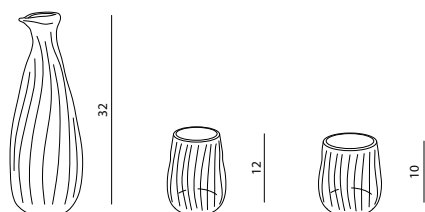

FABULA HORUS

CARAFFA E BICCHIERI - CARAFE AND GLASSES
Marta Giardini

Caraffa e bicchieri realizzati in prezioso vetro di Murano dalle tinte intense, soffiati a bocca e lavorati a mano libera.

Carafe and glasses made in precious Murano glass with intense hues, all the pieces are blown and crafted by hand.

[click here](#)

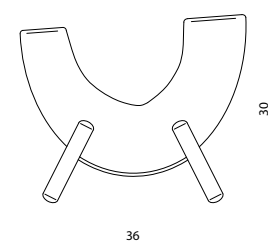

FAUNA CAVALLO

VASO - VASE
Sara Ricciardi

Vaso in vetro con struttura portante in ottone. Edizione limitata e numerata di 60 pezzi per soggetto, in collaborazione con Venini.

Glass vase with supporting structure in brass. Limited and numbered edition of 60 pieces per subject, in collaboration with Venini.

[click here](#)

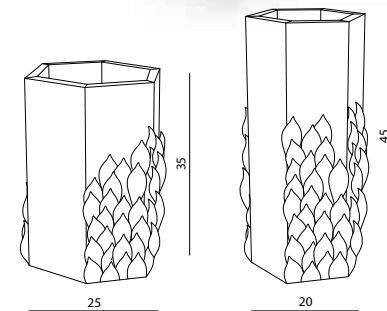

FOGLIA

VASI - VASES
Zanellato/Bortotto

Vasi in legno laccato con applicazioni a mano di specchi argentati a mano e foglie di vetro realizzate secondo la tradizione Muranese.

Vases in lacquered wood with application of handmade silver mirrors and leaves of glass made with the traditional methods of Murano.

[click here](#)

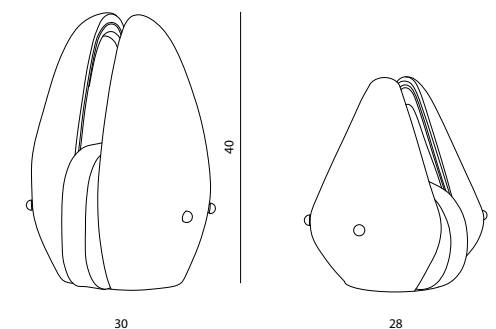

FAUNA SCARABEO 1 - 2

VASI - VASES
Sara Ricciardi

Vaso in vetro con struttura portante in ottone. Edizione limitata e numerata di 60 pezzi per soggetto, in collaborazione con Venini.

Glass vase with supporting structure in brass. Limited and numbered edition of 60 pieces per subject, in collaboration with Venini.

Winner of the 2019 Archiproducts Design Awards, "Decor" category

[click here](#)

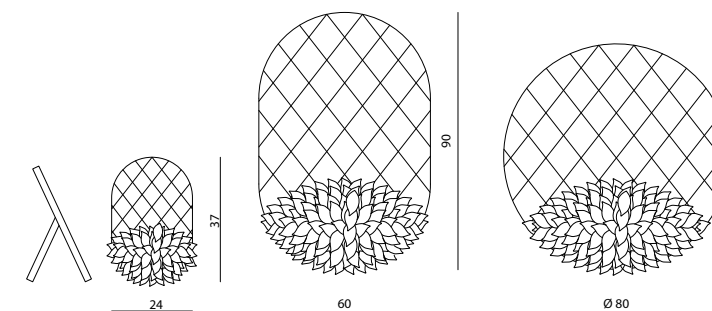

FOGLIA

SPECCHI - MIRRORS
Zanellato/Bortotto

Specchi da tavolo e da parete realizzati secondo la tradizione muranese, con applicazione di specchi argentati tagliati e molati artigianalmente e foglie in vetro applicate a mano.

Table and wall mirrors made with traditional methods of Murano, with application of handcrafted cut and ground silver mirrors and glass leaves applied by hand.

[click here](#)

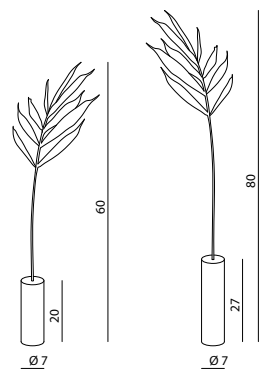

KENTIA PALM

SCULTURA IN MARMO - MARBLE SCULPTURE

Inderjeet Sandhu

Scultura realizzata artigianalmente, cilindro di base in marmo lucidato manualmente e soggetto floreale in ottone. Ogni oggetto è da considerarsi "pezzo unico".

Handcrafted sculpture, manually polished marble base cylinder and floral brass subject. Each object is to be considered a "unique piece".

[click here](#)

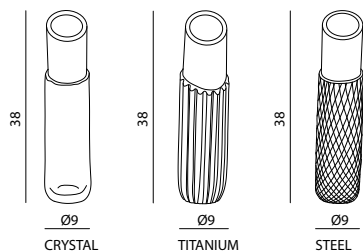

LIPSTICK

VASI - VASES

Stories of Italy

Vasi in vetro di Murano soffiato a bocca e molato a mano, strato esterno con motivo a coste verticali, romboidale o irregolare intagliato nella parte superiore con parte scoperta sabbiata.

Handcrafted blown and ground Murano glass vases. The outer layer with a motif of vertical, rhomboidal or irregular ribbing, is then carved in the upper part, while the exposed part is sandblasted.

[click here](#)

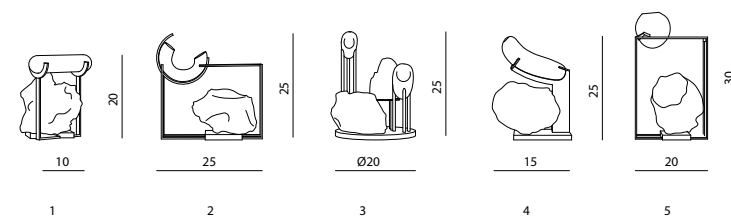

METAMORFOSI

VASI - VASES

Sara Ricciardi

Collezione di vasi in vetro con struttura in ottone. Le caratteristiche del vetro grezzo utilizzato rendono ogni opera un "pezzo unico".

Collection of glass vases with brass structure. The characteristics of the raw glass used make each work a "unique piece".

[click here](#)

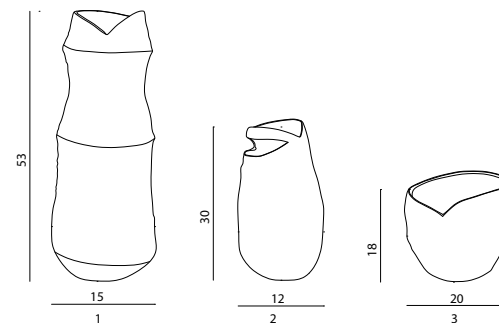

ORÉE

VASI - VASES

Claire Fréchet

Vasi in ceramica-grès porcellanato lucidato e texturizzato all'esterno, smaltato all'interno. La lavorazione è interamente manuale. Effetto fumé e decorazione con patine speciali. Le tonalità delle texture e delle patine possono variare da un esemplare all'altro.

The vases are in ceramics-stoneware polished and textured outside and glazed inside. All hand made. Smoked and adorned with special patinas. Some shades of the textures and patinas can vary a little from one piece to another.

[click here](#)

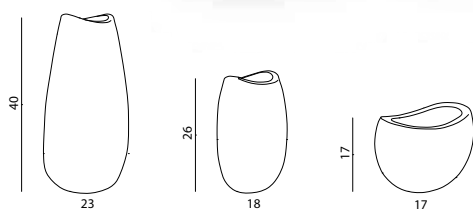

MAREA

VASI - VASES

Zanellato/Bortotto

Vasi in vetro di Murano soffiato a mano. I giochi di colore e sfumature ricreano il movimento delle onde ed il variare della marea.

Vases in handcrafted blown Murano glass. The games of color and shadings reproduce the movement of the waves and the shifting of the tide.

[click here](#)

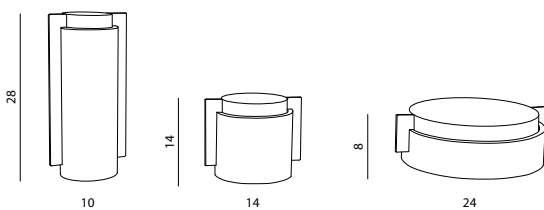

MECCANISMI

SCATOLE - BOXES

Gumdesign

Contenitori composti da elementi in Pietra di Jerissa e in metallo naturale acidato. L'elemento in Pietra di Jerissa è lavorato a Cnc con frese ad alta precisione; l'elemento in metallo è tornito e saldato a mano, successivamente acidato con sensibilità artigianale.

Collection of storage elements composed of parts in Jerissa stone and natural acid-etched metal. The Jerissa stone is worked with high-precision CNC milling; the metal is turned and welded by hand, and then etched with an artisanal approach.

[click here](#)

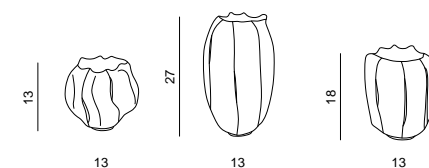

BLACK SEEDS

VASI - VASES

La Conca

Vasi in grès nero lavorati a mano al tornio e cotti a 1200°C, decorati a mano a pennello con frammenti di oro zecchino.

Black stoneware vases handcrafted on a lathe and fired at 1200°C, hand-brushed decorated with fragments of pure gold.

[click here](#)

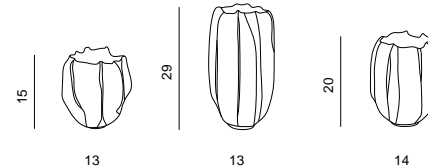

WHITE SEEDS

VASI - VASES

La Conca

Vasi in grès bianco lavorati a mano al tornio e cotti a 1200°C, decorati a mano a pennello con frammenti di oro zecchino.

White stoneware vases handcrafted on a lathe and fired at 1200°C, hand-brushed decorated with fragments of pure gold.

[click here](#)

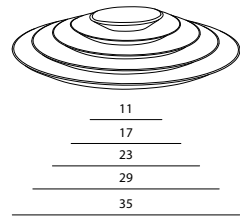

STRATIGRAFICA

PIATTI - PLATES
Gumdesign

Set di 5 piatti/vassoi da portata in marmo pregiato Salomè lavorato interamente a mano.

Set of 5 plates/trays in fine Salomè marble, entirely made by hand.

[click here](#)

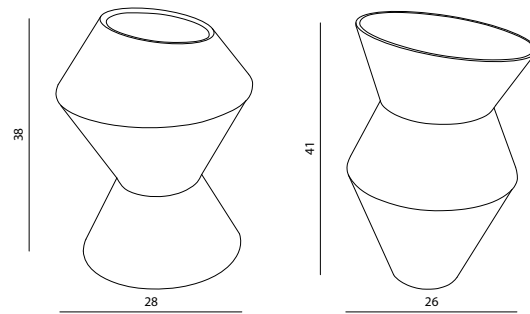

SWING

VASI - VASES
Fausto Salvi

Vasi in ceramica realizzati a mano in tre parti foggiate al tornio e successivamente assemblate, rifiniti con una smaltatura bicolore a spruzzo. Ogni opera è da considerarsi "pezzo unico".

Hand-made ceramic vases made in three parts, turned at the wheel and then assembled, refined with two-tone sprayed glaze. Each item should be considered a "one-of-a-kind" creation.

[click here](#)

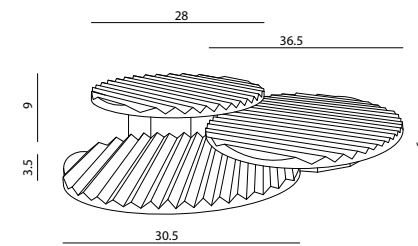

ZIG-ZAG

VASSOI - TRAYS
Fausto Salvi

Set di tre alzate in ceramica con sezione a zig-zag con finitura realizzata tramite smaltatura bicolore a spruzzo. Ogni opera è di fatto da considerarsi "pezzo unico".

Set of three serving ceramic stands, with cross-section of each level and a two-tone sprayed glaze. Each item should be considered a "one-of-a-kind" creation.

[click here](#)

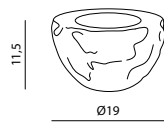

TITANIUM BOWL

CIOTOLA - BOWL
Stories of Italy

Ciotola in vetro di Murano soffiato a bocca e molato a mano, strato esterno a motivo irregolare ed intagliato nella parte superiore con parte scoperta sabbata.

Handcrafted blown and ground Murano glass bowl; the outer layer, with a motif of irregular ribbing, is then carved in the upper part, while the exposed part is sandblasted.

[click here](#)

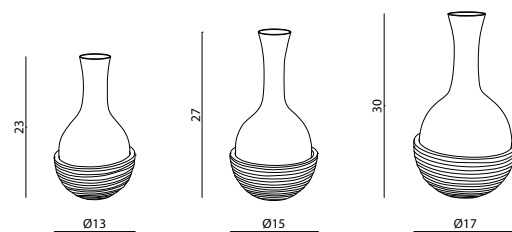

VERSANTE

AMPOLLE - AMPOULES
Gumdesign

Ampolle in cristallo soffiate a bocca, posate su conche levigate internamente e strutturate esternamente in marmo Brown Fantasy lavorato al tornio manuale.

Hand-blown crystal ampoules, laid on internally honed basins and externally structured in hand crafted Brown Fantasy marble.

[click here](#)

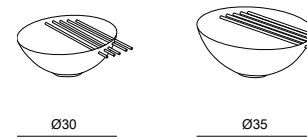

ZEN

CIOTOLA - BOWL
La Conca

Ciotola zen in ceramica, cristallina turchese Ø 30 cm con fori, 5 bacchette in ottone lungh. 34,5 Ø0,7 cm.

Ciotola zen in ceramica, cristallina turchese Ø 35 cm con fori, 5 bacchette in ottone lungh. 38,5 Ø0,7 cm.

Ceramic zen bowl, turquoise crystal Ø 30 cm with holes, 5 brass rods 34,5 Ø0,7 cm.

Ceramic zen bowl, turquoise crystal Ø 35 cm with holes, 5 brass rods 38,5 Ø0,7 cm.

[click here](#)

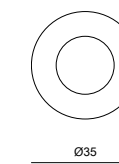

GANYMEDE

PIATTI - PLATES
La Conca

Piatti in maiolica smaltata a mano con applicazione di fotoceramica a gran fuoco, diam. 35 cm

Disponibili in versione Patagonia o Fusion.

Hand-enamelled majolica plates with photo ceramic firing application diam. 35 cm

Available in Patagonia or Fusion.

[click here](#)

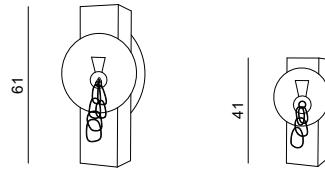
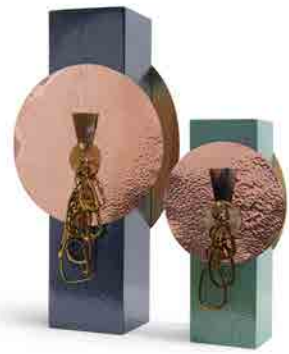

TOTEM 1

VASI - VASES

La Conca

Vaso parallelepipedo in ceramica, cristallina grigio-blu, ovale 27x42 cm ottone lucido + tondo rame Ø30 cm metà martellato metà lucido, 2 collane ovali sottili oro, 4 elementi in osso, 2 chiodi con vite ottone e brugole. H.61 cm.

Vaso parallelepipedo in ceramica, cristallina verde turchese, ovale 18x26 cm ottone lucido + tondo Ø22 cm rame martellato, 2 collane ovali oro, 4 elementi in osso, 2 chiodi con vite ottone e brugole. H.41 cm.

Ceramic parallelepiped vase, crystal grey-blue, oval 27x42 cm polished brass + round copper Ø30 cm half hammered half polished, 2 thin oval gold necklaces, 4 bone elements, 2 nails with brass screw and allen wrenches. H.61 cm.

Ceramic parallelepiped vase, turquoise green crystal, oval 18x26 cm polished brass + round Ø22 cm hammered copper, 2 gold oval necklaces, 4 bone elements, 2 nails with brass screw and allen wrenches. H.41 cm.

 [click here](#)

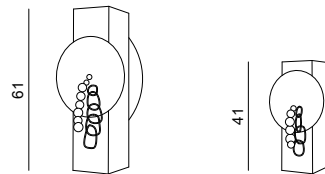

TOTEM 3

VASI - VASES

La Conca

Vaso parallelepipedo in ceramica, cristallina verde, ovale 27x42 cm ottone lucido + tondo rame Ø30 cm metà martellato metà lucido, 2 collane ovali argento, 2 collane a palle nere, 2 chiodi con vite ottone e brugole. H.61 cm.

Vaso parallelepipedo in ceramica, cristallina tortora, ovale 18x26 cm ottone lucido + tondo Ø22 cm rame tutto martellato, 2 collane ovali argento, 2 collane a palle nere, 2 chiodi con vite ottone e brugole. H.41 cm.

Ceramic parallelepiped vase, green crystal, oval 27x42 cm polished brass + round copper Ø30 cm half hammered half polished, 2 oval necklaces silver, 2 black ball necklaces, 2 nails with brass screw and allen screws. H.61 cm.

Ceramic parallelepiped vase, taupe crystal, oval 18x26 cm polished brass round Ø22 cm copper all hammered, 2 silver oval necklaces, 2 black ball necklaces, 2 nails with brass screw and allen wrenches. H.41 cm.

[click here](#)

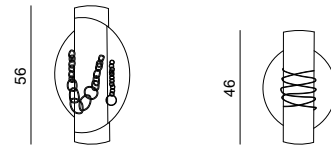

TOTEM 2

VASI - VASES

La Conca

Vaso Bustier in ceramica, cristallina uva, orecchie in ottone, collana ovali argento, cordino in pelle nera, chiodo con vite ottone e brugola. H 56 cm.

Vaso Bustier in ceramica, cristallina verde, orecchie in ottone, collana ovali oro, cordino in pelle nera, chiodo con vite ottone e brugola. H 46 cm.

Ceramic Bustier vase, grape crystalline, brass ears, necklace with silver ovals, black leather cord, nail with brass screw and allen key. H 56 cm.

Ceramic Bustier vase, green crystal, brass ears, necklace with gold ovals, black leather cord, nail with brass screw and allen wrench. H 46 cm.

[click here](#)

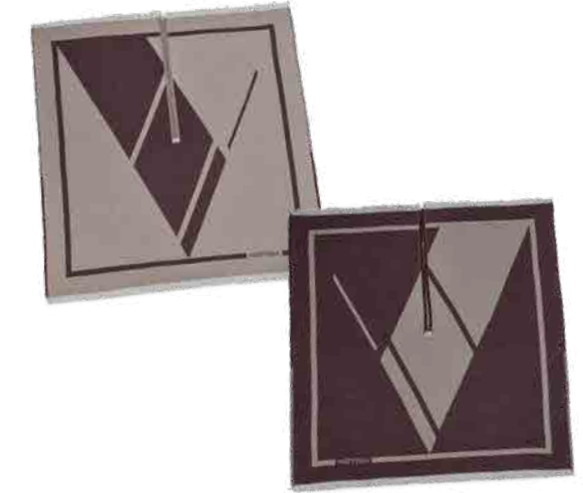

MANTELLA-PLAID

MANTELLA/PLAID - CAPE/PLAID

Mantella / Plaid double-face in lana con taglio centrale per l'indosso. Disponibile con pattern caratterizzato dal monogramma "V" o in versione "V" logo all over. Dimensioni: 150x150 cm.

Double-sided wool cape / plaid with central cut for wearing. Available with pattern characterized by the "V" monogram or in the "V" version with all over logo. Size: 150x150 cm.

[click here](#)

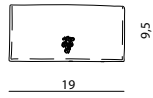

EXPLORER

PORTAFOGLI "CONTINENTAL" - "CONTINENTAL" WALLET
Monica Cantelli

Portafogli in pelle stampata con tasche interne portatessere, logo Visionnaire impresso a caldo. Tasca interna con cerniera lampo e cursore in pelle. Logo Visionnaire esterno in metallo finitura oro. Disponibile in colore rosa, nero, beige. Dimensioni 19x19,5 cm.

Wallet in embossed leather, internal card slots, hot-stamped Visionnaire logo. Internal zip pocket with leather slider. External Visionnaire logo in metal finished with gold lacquer. Available in pink, black, beige. Size 19x19,5 cm.

[click here](#)

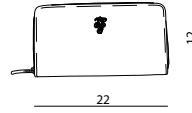

EXPLORER

PORTAFOGLI "ZIP AROUND" - "ZIP AROUND" WALLET
Monica Cantelli

Portafogli in pelle stampata con cerniera lampo su tre lati e cursore metallico con logo Visionnaire. Tasche interne portatessere, logo Visionnaire impresso a caldo. Due tasche a soffietto, tasca con cerniera e cursore in pelle. Logo Visionnaire esterno in metallo finitura oro. Disponibile in colore arancio, nero, beige. Dimensioni 22x12 cm.

Wallet in embossed leather with zip fastening and slider in steel with engraved Visionnaire logo. Internal card slots, hot-stamped Visionnaire logo. Two large compartment, one zip pocket with leather slider. External Visionnaire logo in metal finished with gold lacquer. Available in orange, black, beige. Size 22x12 cm.

[click here](#)

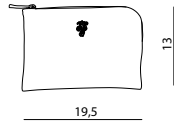

EXPLORER

CLUTCH
Monica Cantelli

Clutch in pelle stampata con cerniera lampo e cursore in pelle. Busta interna estraibile con tasche portatessere, logo Visionnaire oro, cerniera lampo e cursore in pelle. Logo Visionnaire esterno in metallo finitura oro. Disponibile in colore beige, nero, arancio. Dimensioni 19,5x13,5 cm.

Clutch in embossed leather with zip fastening and slider in leather. Internal removable pouch with card slots, Visionnaire logo, zip fastening and leather slider. External Visionnaire logo in metal finished with gold lacquer. Available in orange, black, beige. Size 19,5x13,5 cm.

[click here](#)



EXPLORER

PORTACHIAVI "ZIP AROUND" - "ZIP AROUND" KEYHOLDER
Monica Cantelli

Portachiavi in pelle stampata con cerniera lampo e logo Visionnaire, cursore in pelle e laccio con anello interno estraibile. Tasca interna con cerniera lampo e cursore in pelle, tasche interne portatessere. Logo Visionnaire esterno in metallo finitura oro. Disponibile in colore nero, arancio, beige. Dimensioni 10,5x7,5 cm.

Keyholder in embossed leather with zip fastening and Visionnaire logo, leather slider and pull-out ring with lace. Internally equipped with zip pocket with leather slider and card slots. External Visionnaire logo in metal finished with gold lacquer. Available in orange, beige, black. Size 10,5x7,5 cm.

[click here](#)

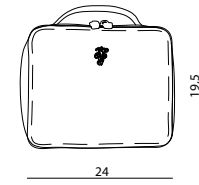

EXPLORER

BEAUTY CASE
Monica Cantelli

Beauty case in pelle stampata con manico, chiusura zip a doppio cursore in metallo con logo Visionnaire. Busta interna estraibile con tasca, chiusura zip e cursore in pelle. Rifinito con interni in nylon ad ovali. Logo Visionnaire esterno in metallo finitura oro. Disponibile in colore nero o celeste. Dimensioni 24x9 H.19 cm.

Beauty case in embossed leather with handle, zip fastening with two sliders in metal with Visionnaire logo. Internal removable pouch with pocket, zip fastening and leather slider. Internal lining in nylon with oval motif. External Visionnaire logo in metal finished with gold lacquer. Available in black or sky blue. Size 24x9 H.19 cm.

[click here](#)



EXPLORER

ZAINO UOMO - MAN BACK-PACK
Monica Cantelli

Zaino in pelle stampata con tasca frontale e spallacci regolabili. Chiusura zip a doppio cursore metallico con logo Visionnaire. Rifinito con interni in fodera a ovali. Logo Visionnaire esterno in metallo finitura oro. Disponibile in colore nero. Dimensioni 32x13H.40 cm.

Back-pack in embossed leather with frontal pocket and adjustable shoulder straps. Zip fastening and two sliders in metal with Visionnaire logo. Internal lining with oval motif. External Visionnaire logo in metal finished with gold lacquer. Available in black only. Size 32x13 H.40 cm.

[click here](#)

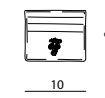

EXPLORER

PORTACARTE - CARD HOLDER
Monica Cantelli

Portacarte in pelle stampata con scomparto centrale e tasche esterne portatessere. Interno in fodera ad ovali, logo Visionnaire esterno in metallo finitura oro. Disponibile in colore nero o beige. Dimensioni 10x8 cm.

Card holder in embossed leather with central compartment and external card slots. Internal lining with oval motif, external Visionnaire logo in metal finished with gold lacquer. Size 10x8 cm.

[click here](#)

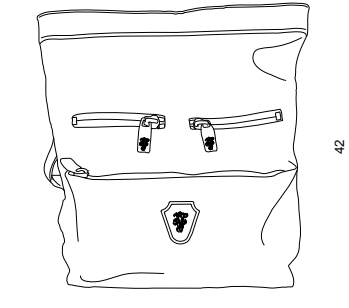

EXPLORER

ZAINO DONNA - WOMAN BACK-PACK
Monica Cantelli

Zaino in pelle stampata con tre tasche frontali, spallacci regolabili, manico e bretella con fibbie metalliche regolabili. Chiusure zip a cursore metallico con logo Visionnaire. Tasca interna con zip. Logo Visionnaire esterno in metallo finitura oro. Disponibile in colore nero. Dimensioni 36x15 H.42 cm.

Printed leather backpack with three front pockets, adjustable shoulder straps, handle and shoulder strap with adjustable metal buckles. Metal slider zip fasteners with Visionnaire logo. Interior zipped pocket. External metal Visionnaire logo in gold finish. Available in black only. Size 36x15 H.42 cm.

[click here](#)

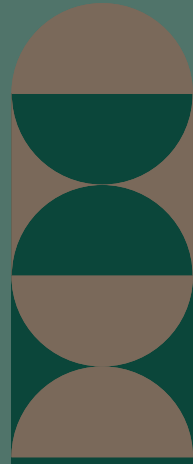

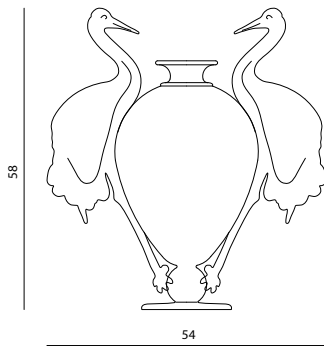

AIRONI

VASO VERONESE - VASE VERONESE

La Conca

Vaso in ceramica fatto a mano smaltato opaco colore tortora con soggetti artistici "aironi" smaltati argento.

Handmade matt tortora-coloured ceramic enamelled vase with silver enamelled herons.

[click here](#)

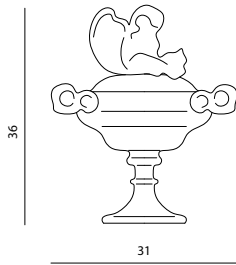

ANAEL

SCRIGNO - CHEST

La Conca

Scrigno verde militare in ceramica con manici oro lucido con soggetto artistico "angelo" grigio opaco.

Polished army green ceramic vase with golden enamelled handles and silver enamelled sculpture.

[click here](#)

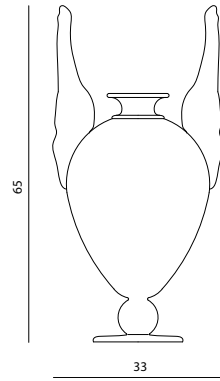

ALI DISCHIUSE

VASO VERONESE - VASE VERONESE

La Conca

Vaso in ceramica fatto a mano smaltato madreperla con soggetti artistici "ali" smaltate argento.

Handmade ceramic glazed mother-of-pearl vase with artistic silver glazed 'wings'.

[click here](#)

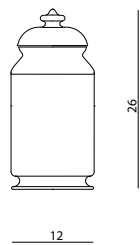

ARNOLFO

VASO IN CERAMICA - CERAMIC VASE

La Conca

Albarelo Ø 12 H.26 cm in ceramica artistica di Faenza disegno righe orizzontali finitura: oro/avorio - platino/avorio - bianco/avorio.

Vase Ø 12 H.26 cm in ceramic from Faenza with horizontal stripes: gold/ivory - platinum/ivory - white/ivory.

[click here](#)

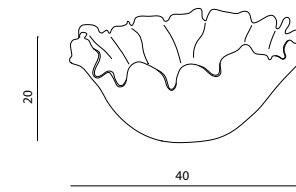

BELLEY

CIOTOLA - BOWL

La Conca

Forma lavorata a mano da lastra di vetro amaranzo di Murano con venature bianche. La tipologia di lavorazione conferisce al vaso caratteristiche di pezzo unico.

Handmade shape from a amaranth Murano glass plate with white veins. The type of processing gives the vase unique piece features.

[click here](#)

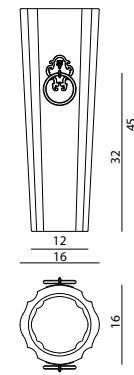

CHANTILLY

VASI - VASES

Alessandro La Spada

Vaso in ceramica con profili in oro zecchino oppure platino. Ai lati sono applicati 2 elementi decorativi a "battacchio" in ottone finitura oro o cromo. Smalto bianco o nero.

Ceramic vase with outline and superior base in gold. Each side has two brass decorative knockers in gold or chrome finishing. Varnish black or white.

[click here](#)

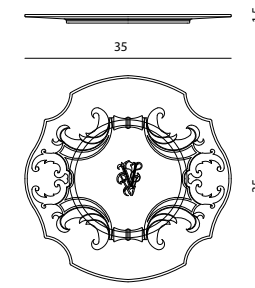

CHANTILLY

PIATTO - PLATE

Alessandro La Spada

Piatto in ceramica smaltata con stemma araldico VISIONNAIRE al centro. Disponibili nelle versioni nero/oro, bianco/oro e nero/bronzo.

Varnish ceramic plate with Visionnaire logo in the middle. Available in black/gold, white/gold and black/bronze.

[click here](#)

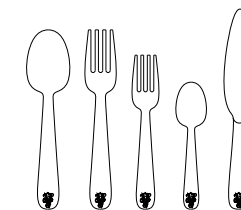

CHERON

SET DI POSATE - CUTLERY SET

Samuele Mazza

Set di posate nere in acciaio inox con punzonatura stemma araldico Visionnaire.

Stainless steel cutlery with punching Visionnaire coat of arms.

[click here](#)

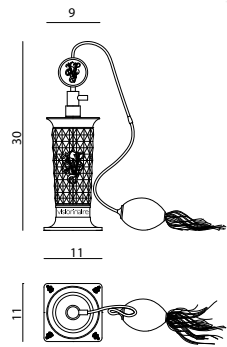

ESMERALDA

DIFFUSORE D'AMBIENTE - PERFUME DIFFUSER

Alessandro La Spada

Diffusore di profumo per ambiente. Colore oro. Dimensioni 11x11 h 30 cm. Bottiglia in cristallo con texture diamond, basamento a base quadra con loghi incisi, anello basamento con scritta Visionnaire a rilievo, pompetta rivestita in tessuto a maglia lucida con nappa color oro.

Perfume diffuser for ambient, gold. Dimensions 11x11 h 30 cm. Perfume diffuser for ambient, diamond textured crystal bottle, square pedestal base with engraved Visionnaire logos, pump covered with knitted fabric and a gold tassel.

[click here](#)

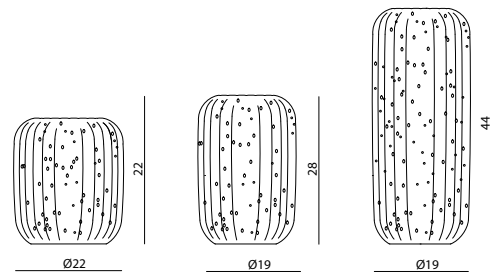

GIDEON

VASO A COSTE - VASE WITH RIBS

Samuele Mazza

Vaso in vetro artistico di Murano soffiato a bocca da maestro vetraio. Sgomatura manuale con tecnica a coste "ballotton". Disponibile nei colori latte, tabacco o borgogna.

Vase in Murano artistic glass blown by mouth by master craftsmen. Shape is given manually with the rib technique "ballotton". Available in milk, tobacco or borgogna colour.

[click here](#)

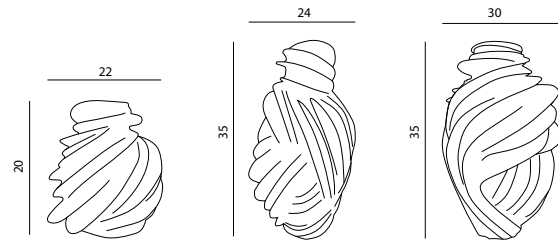

GHIBLI

VASO - VASE

La Conca

Vaso in ceramica realizzato a mano con cuore tornito e fasce applicate singolarmente. Finitura smaltata a forno. Opzione: finitura oro o platino.

Handmade ceramic vase with turned structure and bands applied individually. Baked enamel finishing. Option: gold or platinum finishing.

[click here](#)

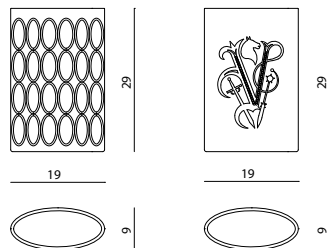

HELMUT

VASO OVALE - OVAL VASE

Samuele Mazza

Vaso in vetro artistico di Murano soffiato a bocca da maestro vetraio. Sgomatura manuale con tecnica a coste "ballotton".

Vase in Murano artistic glass blown by mouth by master craftsmen. Shape is given manually with the rib technique "ballotton".

[click here](#)

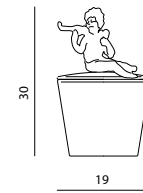

HORNY

VASO PORTA-CANDELA - CANDLE-HOLDER VASE

La Conca

Vaso porta-candela in ceramica fatto a mano, smaltato lucido colore blu scuro con scultura in platino. Candela in cera senza tossine. Peso della cera 1,6 kg.

Handmade ceramic candle vase and cover in polished dark blue, sculpture in platinum. Toxic free candle. Scented wax, weight 1,6 kg.

[click here](#)

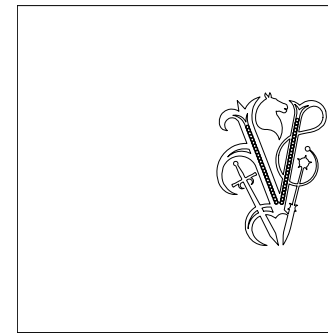

JADIS

TOVAGLILO, TOVAGLIETTA - NAPKIN, PLACEMAT

La Conca

Dimensioni 50x50 cm. Tovagliolo con stemma araldico Visionnaire ricamato su satin nero.

Dimensions 50x50 cm. Napkin with Visionnaire coat of arms embroidered on black satin.

[click here](#)

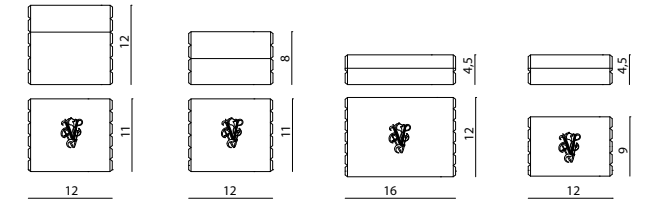

IRMA

SCATOLA - BOX

Alessandro La Spada -Samuele Mazza

Cristallo puro soffiato a bocca, incamiciato e molato interamente a mano, lavorato principalmente con tagliao diamante secondo tecniche e procedimenti della tradizione artigianale del "Made in Italy", con stemma araldico Visionnaire inciso.

Objects made in mouth blown pure crystal, shaped and grinded entirely by hand, is processed principally by diamondcut as per techniques and procedures of the artisan tradition of "Made in Italy", with Visionnaire engraved coat of arms.

[click here](#)

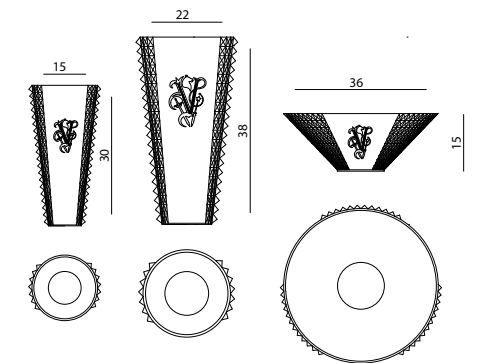

JOSKA

VASO CONICO, COPPA - CONIC VASE, BOWL

Samuele Mazza

Vaso in cristallo di colore nero a forma tronco conica con stemma araldico Visionnaire inciso a mano.

Vase in black crystal with cone trunk form with "diamond" entirely made by hand. Double Visionnaire coat of arms engraved.

[click here](#)

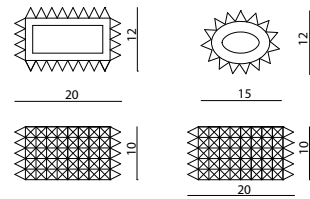

KRAKEN

POSACENERE - ASHTRAY
La Conca

Posacenere in cristallo con lavorazione a cuspidi con stemma araldico inciso all'interno.

Ashtray in crystal with cusp working with Visionnaire coat of arms engraved inside.

● [click here](#)

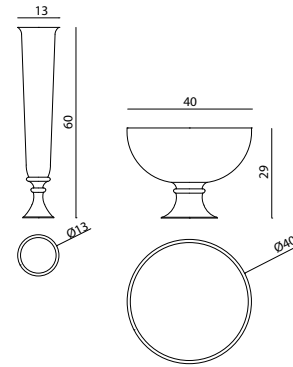

MITHRA

VASO IN CERAMICA - CERAMIC VASE
La Conca

Monofiore Ø 13 H. 60 cm. Vaso in ceramica artistica di Faenza finitura esterno oro o platino interno avorio alzata Ø 40 H. 29 cm. Ciotola con piede in ceramica artistica di Faenza finitura esterno platino o oro, interno avorio.

Single flower holder Ø 13 H. 60 cm. Vase in ceramic from Faenza external: platinum or gold - internal: ivory stand Ø 40 H. 29 cm. Bowl with feet in ceramic from Faenza external: platinum or gold - internal: ivory.

● [click here](#)

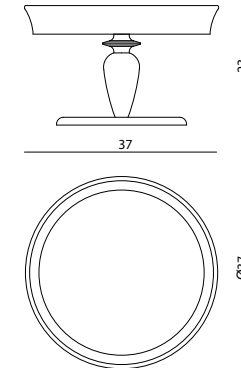

NIBELUNG

FRUTTIERA - FRUIT BOWL
Samuele Mazza

Ceramiche artistiche impreziosite da un decoro esterno in oro zecchino o platino, applicato a pennello e cottura a terzo fuoco. Interno colore bianco.

Artistic ceramics externally enriched in fine gold or platinum, applied by brush and fire baked. Internal colour white.

● [click here](#)

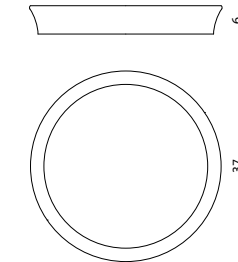

NIBELUNG

VASSOIO - TRAY
Samuele Mazza

Ceramiche artistiche impreziosite da un decoro esterno in oro zecchino o platino, applicato a pennello e cottura a terzo fuoco. Interno colore bianco.

Artistic ceramics externally enriched in fine gold or platinum, applied by brush and fire baked. Internal colour white.

● [click here](#)

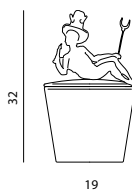

MORAX

VASO PORTA-CANDELA - CANDLE-HOLDER VASE
La Conca

Vaso porta-candela in ceramica fatto a mano, smaltato lucido colore nichel nero con scultura nichel nero e dettagli oro. Candela in cera senza tossine. Peso della cera 1,6 kg.

Handmade ceramic candle vase and cover in polished black nickel, sculpture in black nickel with golden details. Toxic free candle. Scented wax, weight 1,6 kg.

● [click here](#)

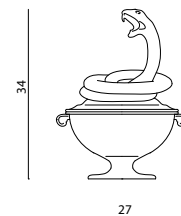

OPHIDIA

SCRIGNO - CHEST
La Conca

Scrigno in ceramica smaltato grigio/blu con soggetto artistico satinato opaco tortora.

Grey/blue glazed ceramic vase with artistic satin matt tortora-coloured sculpture.

● [click here](#)

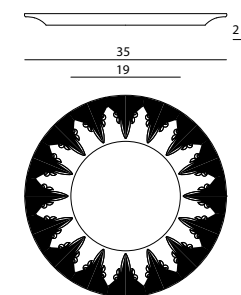

NIBELUNG

SOTTOPIATTO - UNDERPLATE
Samuele Mazza

Ceramiche artistiche impreziosite da una decorazione a rilievo sul bordo, disegno "Visionnaire" in oro zecchino o platino, applicato a pennello e cottura a terzo fuoco. Interno colore bianco.

Artistic ceramics enriched by an embossed decoration on the border, "Visionnaire" logo in fine gold or platinum, applied by brush and fire baked. Internal colour white.

● [click here](#)

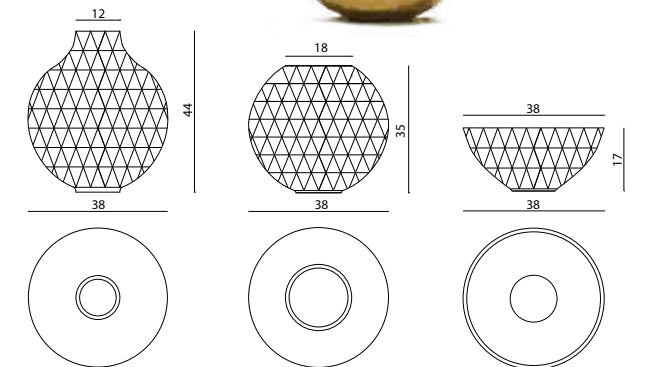

NIBELUNG

VASO, CIOTOLA - VASE, BOWL
Samuele Mazza

Ceramiche artistiche impreziosite da un decoro esterno, disegno "diamante" in oro zecchino o platino, applicato a pennello e cottura a terzo fuoco. Interno colore bianco.

Artistic ceramics enriched by an external decor, "diamond" in fine gold or platinum, applied by brush and fire baked. Internal colour white.

● [click here](#)

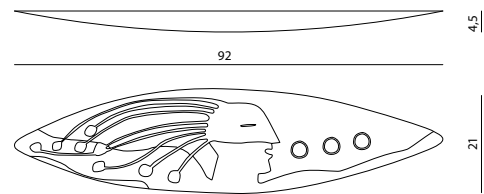

OGIVA-1

VASSOIO - TRAY

Pastore e Bovina

Porcellana stampata e dipinto a mano, ingobbi, ossidi, cristallina, oro applicato a mano a terzo fuoco, cottura a 1170°C.

Printed and hand painted porcelain, slipware, oxides, crystalline, gold applied by hand with a third fire method, baked at 1170°.

● [click here](#)

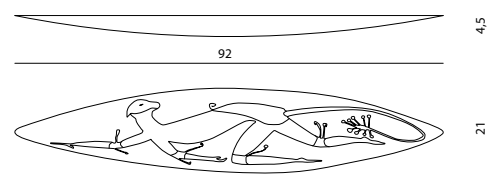

OGIVA-2

VASSOIO - TRAY

Pastore e Bovina

Porcellana stampata e dipinto a mano, ingobbi, ossidi, cristallina, oro applicato a mano a terzo fuoco, cottura a 1170°C.

Printed and hand painted porcelain, slipware, oxides, crystalline, gold applied by hand with a third fire method, baked at 1170°.

● [click here](#)

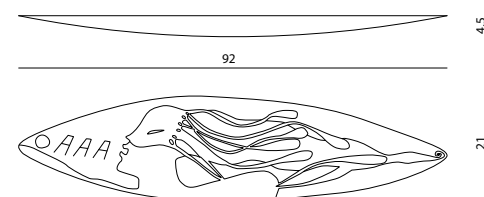

OGIVA-3

VASSOIO - TRAY

Pastore e Bovina

Porcellana stampata e dipinto a mano, ingobbi, ossidi, cristallina, oro applicato a mano a terzo fuoco, cottura a 1170°C.

Printed and hand painted porcelain, slipware, oxides, crystalline, gold applied by hand with a third fire method, baked at 1170°.

● [click here](#)

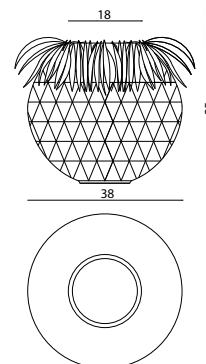

PINKAS

VASO - VASE

Samuele Mazza

Ceramica artistica impreziosita da decoro esterno, disegno "diamante" con finitura a smalto, disponibile nella versione: nero lucido (coloritura per immersione) oppure verde (coloritura a pennello). Adornata con piume di gallo italiano in colore nero bronzato.

Artistic ceramics embellished by external decorations, "diamante" with enamel finish, available in versions: gloss black (coloured by immersion) or green (coloured brush). Adorned with Italian rooster feathers in colour bronzed black.

● [click here](#)

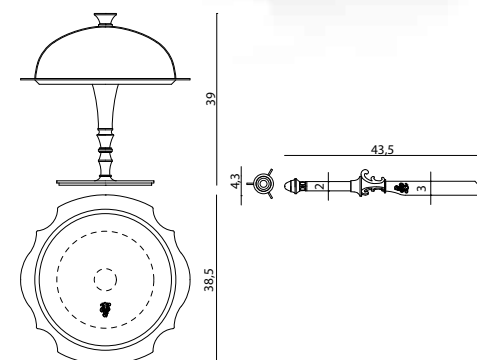

POFFERT

ALZATA PER TORTE, COLTELLO SERVIZIO DOLCI

CAKE STAND, CAKE KNIFE

Alessandro La Spada

Stelo ad elementi in corno e tornerie in ottone argentato. Coperchio in vetro con pomolo ottone, con logo Visionnaire. Coltello: manico in corno e ottone argentato o argento massiccio. Lama in acciaio.

Stem composed by horn and turned silver brass. Cap in glass with brass bowl with Visionnaire logo. Knife: hit in horn and silver brass. Blade in stainless steel.

● [click here](#)

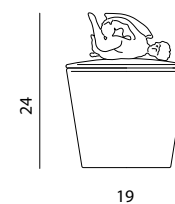

REVEL

VASO PORTA-CANDELA - CANDLE-HOLDER VASE

La Conca

Vaso porta-candela in ceramica fatto a mano, smaltato madreperla verde con scultura argento. Candela in cera senza tossine. Peso della cera 1,6 kg.

Handmade ceramic candle vase and cover in polished green mother-of-pearl with sculpture in silver. Toxic free candle. Scented wax, weight 1,6 kg.

● [click here](#)

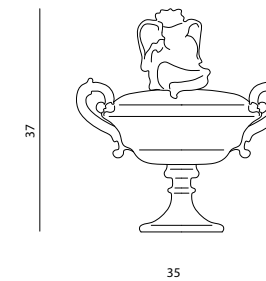

RAGUEL

SCRIGNO - CHEST

La Conca

Scrigno in ceramica smaltato argento con soggetto artistico smaltato oro.

Silver glazed ceramic vase with artistic gold glazed sculpture.

● [click here](#)



RUNNER

TOVAGLIETTA LUNGA - PLACEMAT LONG

Philippe Montels

Tovaglietta in maglia acciaio inox e oro. Dimensioni 198x24 cm.

Stainless steel placemat. Dimensions 198x24 cm.

● [click here](#)

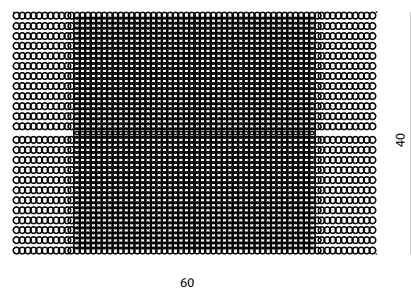

SAILLE

PORTA TOVAGLILOLO, TOVAGLIETTA - NAPKIN, PLACEMAT
Samuele Mazza - Philippe Montels

Tovaglietta in maglia acciaio inox. Dimensioni 40x60 cm.

Stainless steel placemat. Dimensions 40x60 cm.

● [click here](#)

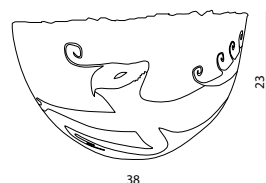

SCIMMIA

CIOTOLA - BOWL
Pastore e Bovina

Porcellana Limoges a colaggio, modellata e dipinta a mano, ingobbi, cristallina, oro applicato a mano a terzo fuoco, cottura a 1260°C.

Casting Limoges porcelain, hand shaped, oxides, crystalline, gold applied by hand with a third fire method, baked at 1260°.

● [click here](#)

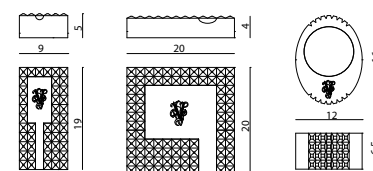

TAZIO

POSACENERE - ASHTRAY
Samuele Mazza

Cristallo puro soffiato a bocca, incamiciato e molato interamente a mano, lavorato principalmente con taglio a diamante secondo tecniche e procedimenti della tradizione artigianale del "Made in Italy", con stemma araldico Visionnaire inciso.

Mouth blown pure crystal, shaped and grinded entirely by hand, is processed principally by diamond cut as per techniques and procedures of the artisan tradition of "Made in Italy" with Visionnaire engraved coat of arms.

● [click here](#)

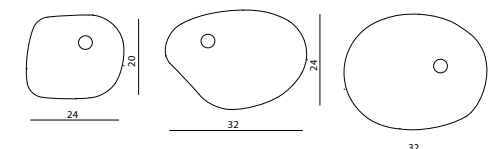

TINNE/F

SASSI IN CERAMICA - CERAMIC STONE
Samuele Mazza

Ceramica artistica a forma di sasso di varie dimensioni, con finitura a smalto disponibile nella versione: verde lucido con riflessi madreperlacei o bianco-avorio. Disponibile nelle versioni: per fissaggio a parete, portafiori oppure lampada con faretto dicroico.

Artistic ceramics in stone form of various dimensions, with enamel finish available in versions: gloss green with mother-of-pearl reflections or ivory-white. Available in versions: for fixing on wall, flower holder or lamp with small bulb.

● [click here](#)

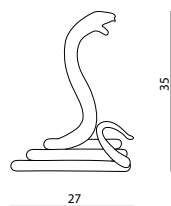

SERPENTE

SCULTURA - SCULPTURE
La Conca

Scultura in ceramica nickel nera.

Black nickel ceramic.

● [click here](#)

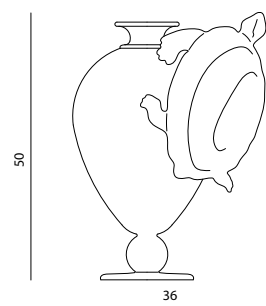

TARTARUGA

VASO VERONESE - VASE VERONESE
La Conca

Vaso in ceramica fatto a mano smaltato opaco colore verde militare con soggetto artistico "tartaruga" smaltato argento.

Matt army green handmade ceramic enamelled vase with silver enameled turtle.

● [click here](#)

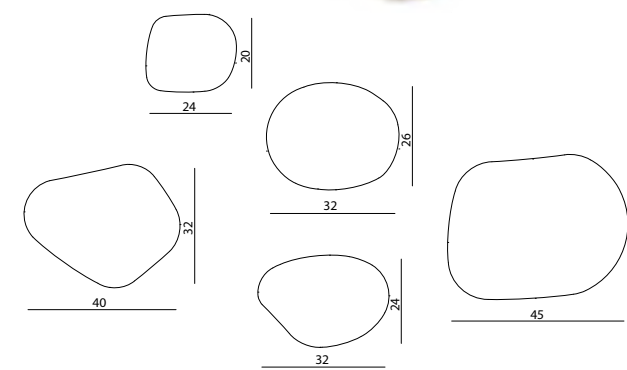

TINNE/P

SASSI IN CERAMICA - CERAMIC STONE
Samuele Mazza

Ceramica artistica a forma di sasso di varie dimensioni, con finitura a smalto disponibile nella versione: verde lucido con riflessi madreperlacei o bianco-avorio. Disponibile nelle versioni: per fissaggio a parete, portafiori oppure lampada con faretto dicroico.

Artistic ceramics in stone form of various dimensions, with enamel finish available in versions: gloss green with mother-of-pearl reflections or ivory-white. Available in versions: for fixing on wall, flower holder or lamp with small bulb.

● [click here](#)

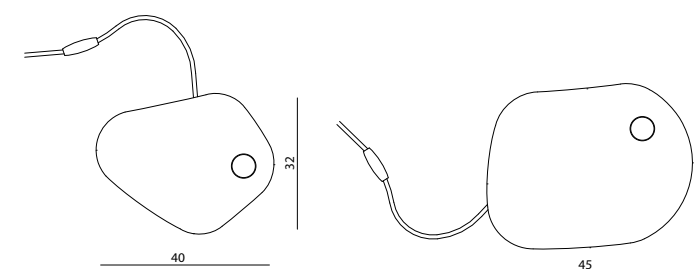

TINNE/L

SASSI IN CERAMICA - CERAMIC STONE
Samuele Mazza

Ceramica artistica a forma di sasso di varie dimensioni, con finitura a smalto disponibile nella versione: verde lucido con riflessi madreperlacei o bianco-avorio. Disponibile nelle versioni: per fissaggio a parete, portafiori oppure lampada con faretto dicroico.

Artistic ceramics in stone form of various dimensions, with enamel finish available in versions: gloss green with mother-of-pearl reflections or ivory-white. Available in versions: for fixing on wall, flower holder or lamp with small bulb.

● [click here](#)

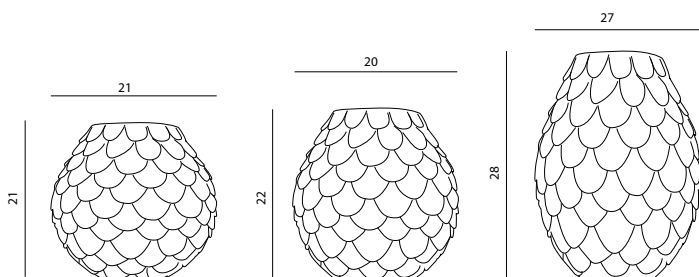

TRITONE

VASO - VASE

La Conca

Vaso in ceramica realizzato a mano con cuore tornito e scaglie applicate singolarmente. Finitura smaltata a forno. Opzione: finitura oro o platino.

Handmade ceramic vase with turned structure and scales applied individually. Baked enamel finishing – Option: gold or platinum finish.

● [click here](#)



UDOLPHO

BICCHIERE, PIATTO FONDO, SOTTOPIATTO, PIATTO FRUTTA

GLASS, SOUP PLATE, SALAD PLATE, SHALLOW PLATE

La Conca

Servizio da tavola in vetro di Murano. Le caratteristiche di unicità degli oggetti Udolpho Murano derivano dalla lavorazione e dalla produzione manuale del vetro. Colore nero/madreperla, avorio/madreperla.

Tableware in Murano glass. The unique characteristics of the Udolpho Murano objects are the result of the manual processing and the peculiar manufacture of the glass. Color black/mother-of-pearl, ivory/mother-of-pearl.

● [click here](#)

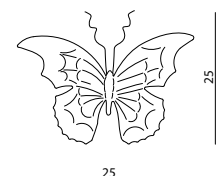

VANESSA

FARFALLA IN CERAMICA - CERAMIC BUTTERFLY

Samuele Mazza

Ceramica artistica interamente realizzata a mano. Smaltatura in bianco e successiva applicazione a pennello di lustrini a base di oro o platino 12/13%. Cottura a terzo fuoco. Antenne in filo metallico ritorto applicate a pasta umida.

Artistic ceramic made entirely by hand. White enamelling and successive application by brush of lustrini base of gold or platinum 12/13%. Fire baked. Antennas in metallic twisted wire, applied with humid paste.

● [click here](#)

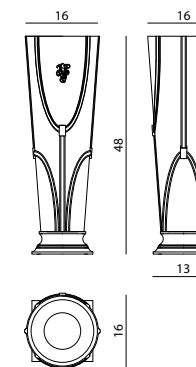

WINDSOR

VASI - VASES

Alessandro La Spada

Vaso in ceramica di colore bianco o nero, con base a pianta quadrata finitura oro zecchino ed elementi decorativi e logo in ottone finitura oro.

Ceramic vase in white or black colour, with square base in gold and decorative details in golden brass.

● [click here](#)

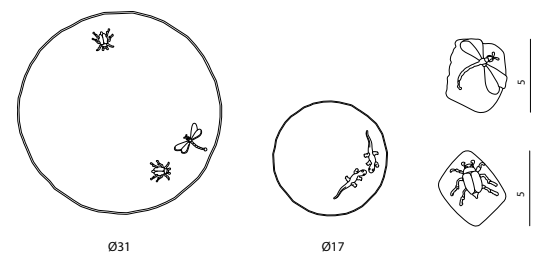

UMBERTO

PIATTO, SEGNAPOSTO - PLATE, PLACEHOLDER

La Conca

Piatto grande e piccolo, disponibili nei colori grigio marmorizzato o verde marmorizzato, con inserto charm. Segnaposto, disponibile con inserto charm ape o libellula.

Plates available in marmored grey or marmored green colour, with charms application. Placeholder with charms application. Available with bee charm or dragonfly charm.

● [click here](#)

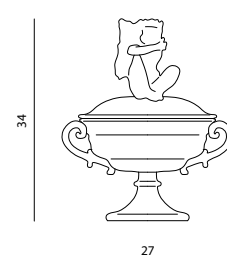

URIEL

SCRIGNO - CHEST

La Conca

Scrigno in ceramica smaltato rame con maniglie e soggetto artistico smaltato argento.

Matt copper enamelled ceramic vase with handles and silver enamelled artistic sculpture.

● [click here](#)

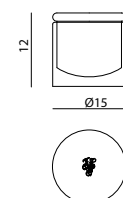

WINX

COFANETTO - CASE

La Conca

Scatola cilindrica con coperchio in cristallo nero/oro con logo Visionnaire in bassorilievo.

Cylindrical case with cover, low-relieved Visionnaire logo, black gold on crystal.

● [click here](#)



ASPEN/AL

CUSCINO - CUSHION

Philippe Montels

Cuscino volante con maglia metallica finitura naturale o champagne.

Loose cushion with natural or champagne lacquered metal chain.

[click here](#)

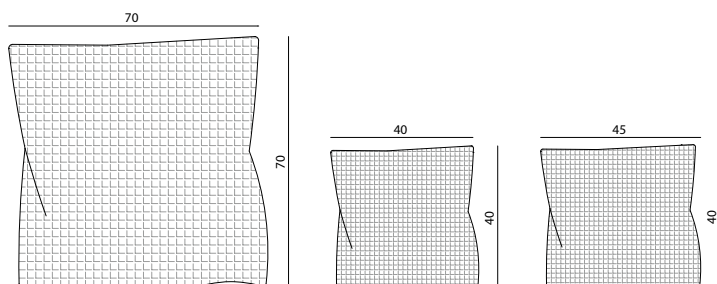

CLAN - cm 240x150

ABSTRACT, CLAN, PAISLEY, TARTAN, TWEED

PLAID

La Conca

Mezzero a doppia stampa con bordo in ecopelle, tessuto 50% Alpaca, 50% Lana, peso 620 gr. ml.

Double printed "mezzero" with ecoleather edge, 50% Alpaca, 50% Wool fabric, weight 620 gr. ml.

[click here](#)



TARTAN - cm 230x140



ABSTRACT - cm 243x135



TWEED - cm 250x150



PAISLEY - cm 250x148



CHAMBRE CINQ

SET DI LENZUOLA, COPRILETTO, PLAID

SET OF SHEETS, BEDCOVER, PLAID

La Conca

Set lenzuola con 2 federe in raso cotone cm 80x50, set di 2 federe in raso cotone supplementari cm 80x50, copriletto in lino con trapuntatura cm 290x246, plaid in lana cm 150x230 con frangia corta.

Set of sheets with 2 pillow cases cm 80x50, set of 2 additional pillow cases cm 80x50, bedcover cm 290x246 in flax, plaid in wool cm 150x230 with short fringe.

[click here](#)



CHAMBRE CINQ

SET DI ASCIUGAMANI - SET OF BATHTOWELS

Set di asciugamani, 100% spugna di cotone con ricamo su bordo in raso di cotone a contrasto, cm 40x60 e 60x120.

Set of bath towels, 100% cotton terry with embroidery on edge in contrasting cotton satin, cm 40x60 and cm 60x110.

[click here](#)





EPOQUE

SET DI LENZUOLA, COPRILETTO, PLAID
SET OF SHEETS, BEDCOVER, PLAID

La Conca

Set lenzuola con 2 federe in lino cm 80x50, set di 2 federe in lino supplementari cm 80x50, copriletto in raso cm 270x270, plaid in cachemire con frangia cm 150x210.

Set of sheets with 2 pillow cases in linen cm 80x50, additional set of 2 pillow cases in linen cm 80x50, bedcover in satin cm 270x270, plaid in cachemire with fringe cm 150x210.

● click here



MEZZARO GLAM

GLAM PLAID

La Conca

Mezzero in tessuto jacquard 70% lana vergine, 15% seta, 15% modal, peso 320 gr.

"Mezzero" in jacquard fabric 70% virgin wool, 15% silk, 15% modal, weight 320 gr.

● click here



MIRABELL

SET DI LENZUOLA, COPRILETTO
SET OF SHEETS, BEDCOVER

La Conca

Set lenzuola con 2 federe in raso cotone 80x50 cm, set di 2 federe supplementari in raso con fasce laterali in velluto e fascia centrale tartanata 65x30 cm, copriletto in cotone con perimetro in velluto, filetti coordinati, e tartanata sul top 280x260 cm.

Set of sheets with 2 cotton satin pillow cases 80x50 cm, set of 2 additional satin pillow cases with velvet side bands and central quilted band 65x30 cm, cotton bedcover with velvet border and matching pipings and quilted top 280x260 cm.

● click here



TECHNO

SET DI LENZUOLA, COPRILETTO
SET OF SHEETS, BEDCOVER

La Conca

Set lenzuola con 2 federe in raso 80x50 cm, set di 2 federe supplementari in raso metallico 30x65 cm, copriletto in cotone con trapuntatura 270x270 cm.

Set of sheets with 2 satin pillow cases 80x50 cm, set of 2 additional metallic satin pillow cases 30x65 cm, cotton bedcover with quilting 270x270 cm.

● click here





SECRET

SET DI LENZUOLA, COPRILETTO - SET OF SHEETS, BEDCOVER
La Conca

Set lenzuola con 2 federe in chambray cm 80x50, set di 2 federe in raso supplementari cm 80x50, copriletto lino con trapuntatura cm 270x270.

Set of sheets with 2 pillow cases cm 80x50 in chambray, set of 2 additional pillow cases in satin cm 80x50, bedcover cm 270x270 in linen with quilting.

[click here](#)



SECRET

SET DI ASCIUGAMANI - SET OF BATHTOWELS

Set di asciugamani, 100% spugna di cotone con ricamo Krizia con bordo in chambray, cm 40x60, cm 60x110.

Set of bath towels, 100% cotton terry with Krizia embroidery in chambray, cm 40x60, cm 60x110.

[click here](#)



WOODSTOCK

SOUNDBAR

La Conca

Sound bar in acciaio inox lucido, sistema audio Hi-Fi Bluetooth a 4 canali + subwoofer da 800W (tensione di alimentazione 220V, dotata di interruttore on/off). Impianto audio costituito da 4 diffusori tweeter/midrange integrati nella struttura ed un subwoofer posizionato all'interno della base in legno, rivestita in pelle o tessuto. Logo e profili in acciaio inox, disponibili in finitura cromo oppure oro. Illuminazione a LED.

Sound bar in shiny stainless steel, 4-channel Hi-Fi bluetooth speaker system + 800W subwoofer (200V voltage supply, equipped with on/off switch). Speaker system consisting of tweeter, integrated mid-range drivers and a subwoofer located inside the wooden base, upholstered in leather or fabric. Logo and profiles in stainless steel, available with chrome or gold lacquered finish. LED light included.

[click here](#)

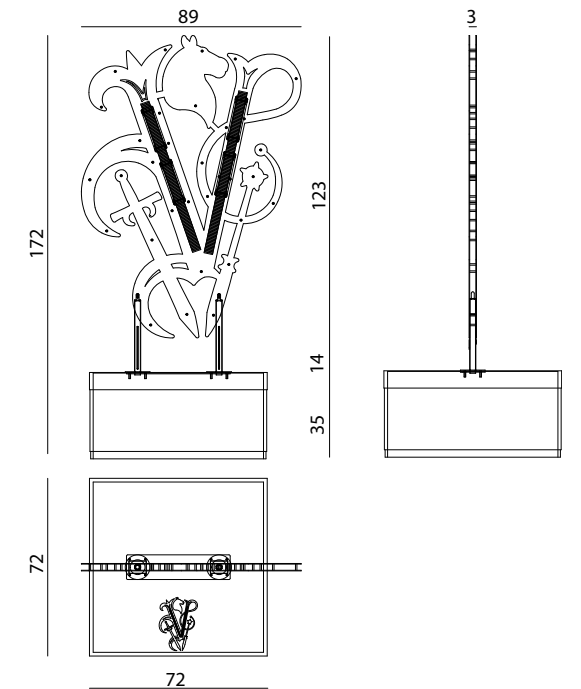

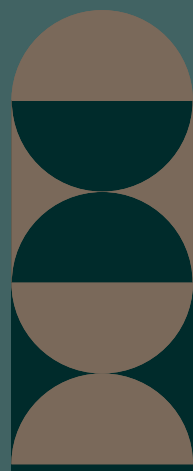

MICHELE ASTOLFI

Appassionato di fotografia e di elaborazione digitale Astolfi sperimenta la combinazione tra l'immagine e diversi materiali come legno fossile, cristalli, madreperla, pietra naturale e acciaio. La ricerca più recente lo avvicina al trattamento pittorico della materia utilizzata rendendo labile il confine tra unicità dell'opera "gioiello" e la sua replicabilità.

Passionate about photography and digital processing, Michele Astolfi experiments the combination between image and different materials such as fossil wood, crystals, mother of pearl, natural stone and steel. The most recent research brings him closer to the pictorial treatment of the used material, making the border between the uniqueness of the "jewel" work and its replicability blurred.



ANATRA IN VOLO

150 x 100 cm

Base in plexiglass con inserti in vetro dipinti a mano, pietra e cristalli Swarovski. Cornice in acciaio disponibile nella selezione finiture metalliche. Plexiglass base with inserts in hand-painted glass, stone and Swarovski crystals. Stainless steel frame available in the metal finishing selection.

[click here](#)

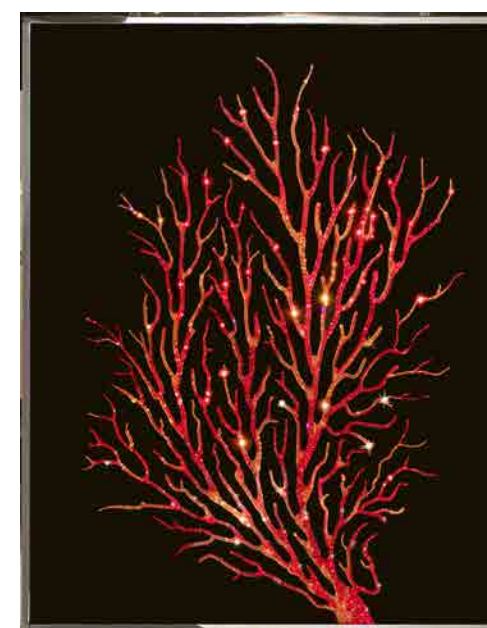

CORALLO

125 x 155 cm

Base in plexiglass con inserti in cristalli Swarovski. Cornice in acciaio disponibile nella selezione finiture metalliche. Plexiglass base with inserts in Swarovski crystals. Stainless steel frame available in the metal finishing selection.

[click here](#)

MIXED MEDIA

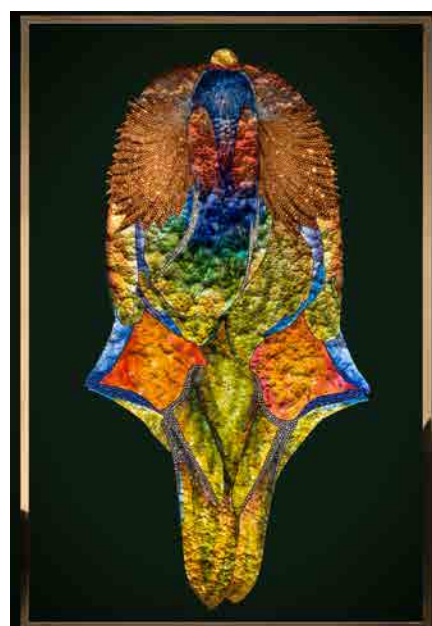

ANATRA MANDARINA

100 x 135 cm

Base in plexiglass con inserti in vetro dipinti a mano e cristalli Swarovski. Cornice in acciaio disponibile nella selezione finiture metalliche. Plexiglass base with inserts in hand-painted glass and Swarovski crystals. Stainless steel frame available in the metal finishing selection.

[click here](#)



FIREBIRD

100 x 160 cm

Base in plexiglass con inserti in vetro artistico di Murano e cristalli Swarovski. Cornice in acciaio disponibile nella selezione finiture metalliche. Plexiglass base with Murano artistic glass inserts and Swarovski crystals. Stainless steel frame available in the metal finishing selection.

[click here](#)



FENICOTTERI IN VOLO

200 x 60 cm

Base in plexiglass con inserti in vetro dipinti a mano e cristalli Svarovski. Cornice in acciaio disponibile nella selezione finiture metalliche.
Plexiglass base with inserts in hand-painted glass and Swarovski crystals. Stainless steel frame available in the metal finishing selection.

● [click here](#)



BROWN FLOWER

140 x 160 cm

Base in plexiglass con inserti in vetro dipinti a mano e cristalli Svarovski. Cornice in acciaio disponibile nella selezione finiture metalliche.
Plexiglass base with inserts in hand-painted glass and Swarovski crystals. Stainless steel frame available in the metal finishing selection.

● [click here](#)



PALMA ARECA

190 x 120 cm

Base in plexiglass con inserti in vetro dipinti a mano. Cornice in acciaio disponibile nella selezione finiture metalliche.
Plexiglass base with inserts in hand-painted glass. Stainless steel frame available in the metal finishing selection.

● [click here](#)



RED FLOWER

140 x 140 cm

Base in plexiglass con inserti in vetro dipinti a mano e cristalli Svarovski. Cornice in acciaio disponibile nella selezione finiture metalliche.
Plexiglass base with inserts in hand-painted glass and Swarovski crystals. Stainless steel frame available in the metal finishing selection.

● [click here](#)



KENTIA

190 x 120 cm

Base in plexiglass con inserti in vetro dipinti a mano e cristalli Svarovski. Cornice in acciaio disponibile nella selezione finiture metalliche.
Plexiglass base with inserts in hand-painted glass and Swarovski crystals. Stainless steel frame available in the metal finishing selection.

● [click here](#)



FENICOTTERO DARK

130 x 175 cm

Base in plexiglass con inserti in vetro dipinti a mano e cristalli Svarovski. Cornice in acciaio disponibile nella selezione finiture metalliche.
Plexiglass base with inserts in hand-painted glass and Swarovski crystals. Stainless steel frame available in the metal finishing selection.

● [click here](#)



GALLO CEDRONE

130 x 130 cm

Base in plexiglass con inserti in vetro dipinti a mano e cristalli Svarovski. Cornice in acciaio disponibile nella selezione finiture metalliche.
Plexiglass base with inserts in hand-painted glass and Swarovski crystals. Stainless steel frame available in the metal finishing selection.

[● click here](#)



PEACOCK

200 x 110 cm

Base in plexiglass con inserti in vetro dipinti a mano e cristalli Svarovski. Cornice in acciaio disponibile nella selezione finiture metalliche.

Plexiglass base with inserts in hand-painted glass and Swarovski crystals. Stainless steel frame available in the metal finishing selection.

[● click here](#)



GRU CORONATA

110 x 160 cm

Base in plexiglass con inserti in vetro dipinti a mano e cristalli Svarovski. Cornice in acciaio disponibile nella selezione finiture metalliche.
Plexiglass base with inserts in hand-painted glass and Swarovski crystals. Stainless steel frame available in the metal finishing selection.

[● click here](#)



TROPICAL

245 x 120 cm

Base in plexiglass con inserti in vetro dipinti a mano e cristalli Svarovski. Cornice in acciaio disponibile nella selezione finiture metalliche.

Plexiglass base with inserts in hand-painted glass and Swarovski crystals. Stainless steel frame available in the metal finishing selection.

[● click here](#)



PARROT FRED

110 x 160 cm

Base in plexiglass con inserti in vetro dipinti a mano e cristalli Svarovski. Cornice in acciaio disponibile nella selezione finiture metalliche.
Plexiglass base with inserts in hand-painted glass and Swarovski crystals. Stainless steel frame available in the metal finishing selection.

[● click here](#)



BLACK FLOWER

135 x 160 cm

Base in plexiglass con inserti in vetro dipinti a mano e cristalli Svarovski. Cornice in acciaio disponibile nella selezione finiture metalliche.
Plexiglass base with inserts in hand-painted glass and Swarovski crystals. Stainless steel frame available in the metal finishing selection.

[● click here](#)



OPIUM

140 x 140 cm

Base in plexiglass con inserti in vetro dipinti a mano e cristalli Svarovski. Cornice in acciaio disponibile nella selezione finiture metalliche.
Plexiglass base with inserts in hand-painted glass and Swarovski crystals. Stainless steel frame available in the metal finishing selection.

● [click here](#)



KOI CARP

180 x 120 cm

Base in plexiglass con inserti in vetro dipinti a mano e cristalli Svarovski. Cornice in acciaio disponibile nella selezione finiture metalliche.
Plexiglass base with inserts in hand-painted glass and Swarovski crystals. Stainless steel frame available in the metal finishing selection.

● [click here](#)



PARROT ARA

70 x 90 cm

Base in plexiglass con inserti in vetro dipinti a mano e cristalli Svarovski. Cornice in acciaio disponibile nella selezione finiture metalliche.
Plexiglass base with inserts in hand-painted glass and Swarovski crystals. Stainless steel frame available in the metal finishing selection.

● [click here](#)

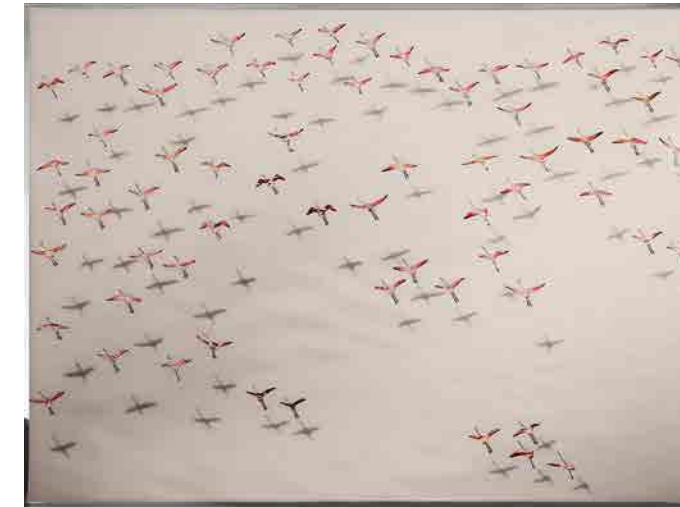

FLAMINGOS

190 x 140 cm

Base in plexiglass con inserti in vetro dipinti a mano e cristalli Svarovski. Cornice in acciaio disponibile nella selezione finiture metalliche.
Plexiglass base with inserts in hand-painted glass and Swarovski crystals. Stainless steel frame available in the metal finishing selection.

● [click here](#)



ORCHIDEA BLU

200 x 130 cm

Base in plexiglass con inserti in vetro dipinti a mano e cristalli Svarovski. Cornice in acciaio disponibile nella selezione finiture metalliche.
Plexiglass base with inserts in hand-painted glass and Swarovski crystals. Stainless steel frame available in the metal finishing selection.

● [click here](#)



BAMBÙ

190 x 130 cm

Base in plexiglass con inserti in vetro dipinti a mano. Cornice in acciaio disponibile nella selezione finiture metalliche.
Plexiglass base with inserts in hand-painted glass. Stainless steel frame available in the metal finishing selection.

● [click here](#)



BIRCHES

190 x 130 cm

Base in plexiglass con inserti in vetro dipinti a mano. Cornice in acciaio disponibile nella selezione finiture metalliche.
Plexiglass base with inserts in hand-painted glass. Stainless steel frame available in the metal finishing selection.

● [click here](#)

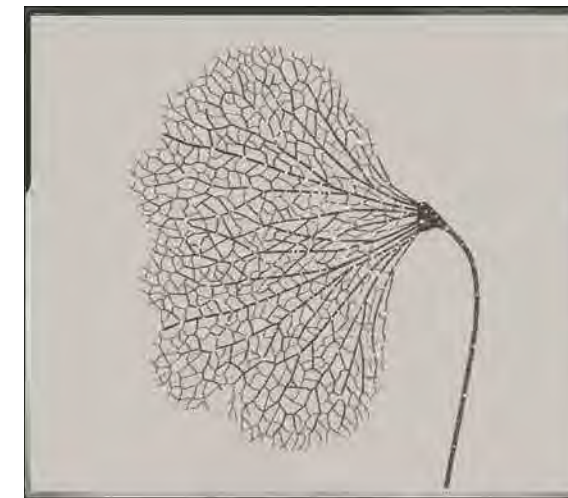

DRY LEAF

150 x 130cm

Base in plexiglass con inserti in cristalli Svarovski. Cornice in acciaio disponibile nella selezione finiture metalliche.
Plexiglass base with inserts in Swarovski crystals. Stainless steel frame available in the metal finishing selection.

● [click here](#)



SWAN

245 x 120 cm

Base in plexiglass con inserti in vetro dipinti a mano e cristalli Svarovski. Cornice in acciaio disponibile nella selezione finiture metalliche.
Plexiglass base with inserts in hand-painted glass and Swarovski crystals. Stainless steel frame available in the metal finishing selection.

● [click here](#)



HERON

180 x 120 cm

Base in plexiglass con inserti in vetro dipinti a mano e cristalli Svarovski. Cornice in acciaio disponibile nella selezione finiture metalliche.
Plexiglass base with inserts in hand-painted glass and Swarovski crystals. Stainless steel frame available in the metal finishing selection.

● [click here](#)



ARBOR

120 x 180 cm

Stampa fotografica su plexiglass con inserti di cristalli Svarovski. Cornice in acciaio disponibile nella selezione finiture metalliche.
Photographic print on plexiglass with inserts of Swarovski crystals. Stainless steel frame available in the metal finishing selection.

● [click here](#)



GREEN DREAM

180 x 120 cm

Base in plexiglass con inserti in vetro dipinti a mano e cristalli Svarovski. Cornice in acciaio disponibile nella selezione finiture metalliche.
Plexiglass base with inserts in hand-painted glass and Swarovski crystals. Stainless steel frame available in the metal finishing selection.

● [click here](#)



LIBELLULA

175 x 140 cm

Base in plexiglass con inserti in vetro artistico e corpo in vetro soffiato di Murano con foglia d'oro 24K.
Base in plexiglass with inserts in Murano blown glass with gold leaf 24K.

● [click here](#)



PIOVRA

140 x 140 cm

Stampa fotografica su plexiglass con inserti in vetro e cristalli Swarovski. Cornice in acciaio disponibile nella selezione finiture metalliche.
Photographic print on plexiglass with inserts in glass and Swarovski crystals. Stainless steel frame available in the metal finishing selection.

● [click here](#)



TROFEO CERVO

180 x 150 cm | 140 x 120 cm

Stampa fotografica su plexiglass con inserti in vetro e cristalli Swarovski. Cornice in acciaio disponibile nella selezione finiture metalliche.
Photographic print on plexiglass with inserts in glass and Swarovski crystals. Stainless steel frame available in the metal finishing selection.

● [click here](#)



BLU MARLIN

201 x 130 cm

Stampa fotografica su plexiglass con inserti in vetro e cristalli Swarovski. Cornice in acciaio disponibile nella selezione finiture metalliche.
Photographic print on plexiglass with inserts in glass and Swarovski crystals. Stainless steel frame available in the metal finishing selection.

● [click here](#)

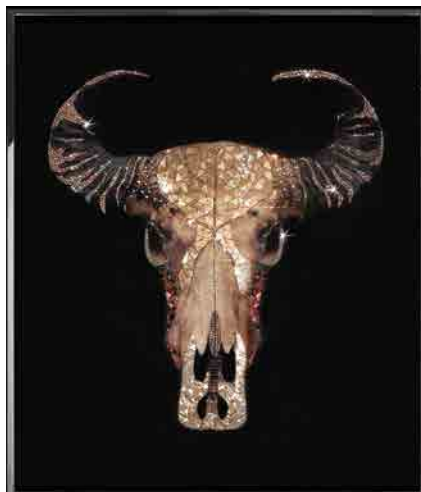

TROFEO BUFALO

120 x 140 cm

Stampa fotografica su plexiglass con inserti in vetro e cristalli Swarovski. Cornice in acciaio disponibile nella selezione finiture metalliche.
Photographic print on plexiglass with inserts in glass and Swarovski crystals. Stainless steel frame available in the metal finishing selection.

● [click here](#)

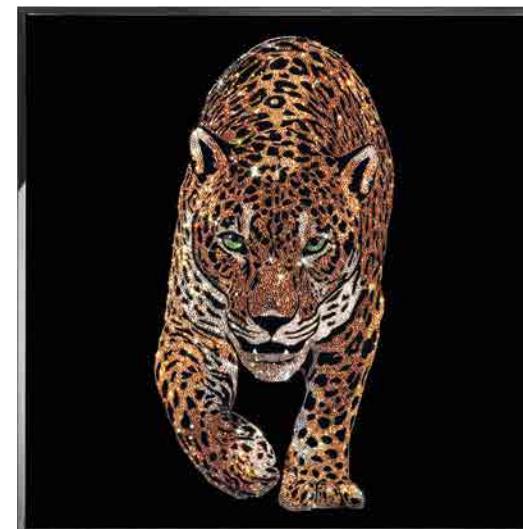

GIAGUARO

140 x 140 cm

Stampa su plexiglass con inserti in cristalli Swarovski.
Print on plexiglass with inserts in crystals Swarovski.

● [click here](#)



DRAGONE

180 x 120 cm

Stampa fotografica su plexiglass con inserti in vetro e cristalli Swarovski. Cornice in acciaio disponibile nella selezione finiture metalliche.
Photographic print on plexiglass with inserts in glass and Swarovski crystals. Stainless steel frame available in the metal finishing selection.

● [click here](#)



COLIBRI E FIORE

170 x 100 cm

Base in plexiglass con inserti in vetro dipinti a mano e cristalli Swarovski. Cornice in acciaio disponibile nella selezione finiture metalliche.
Plexiglass base with inserts in hand-painted glass and Swarovski crystals. Stainless steel frame available in the metal finishing selection.

● [click here](#)

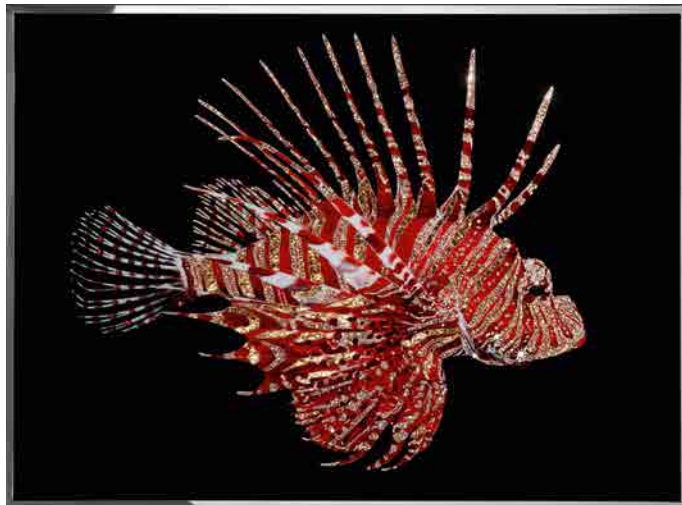

PESCE SCORPIONE

160 x 120 cm

Stampa fotografica su plexiglass con inserti in vetro e cristalli Swarovski. Cornice in acciaio disponibile nella selezione finiture metalliche.
Photographic print on plexiglass with inserts in glass and Swarovski crystals. Stainless steel frame available in the metal finishing selection.

● [click here](#)



CHINESE DRAGON

190 x 100 cm

Base in plexiglass con inserti a mosaico in vetro artistico di Murano e cristalli Swarovski. Cornice in acciaio disponibile nella selezione finiture metalliche.
Plexiglass base with mosaic inserts in Murano artistic glass and Swarovski crystals. Steel frame available in a selection of metal finishes.

● [click here](#)



GOLDEN FISH

180 x 120 cm

Base in plexiglass con inserti in vetro e cristalli Swarovski.
Base in plexiglass with inserts in glass and Swarovski crystals.

● [click here](#)



SILVER HORSE

180 x 120 cm

Base in plexiglass con inserti in vetro artistico di Murano e cristalli Swarovski. Cornice in acciaio disponibile nella selezione finiture metalliche.
Plexiglass base with Murano artistic glass inserts and Swarovski crystals. Stainless steel frame available in the metal finishing selection.

● [click here](#)



GOLDEN HORSE

180 x 120 cm

Base in plexiglass con inserti in vetro artistico di Murano e cristalli Swarovski. Cornice in acciaio disponibile nella selezione finiture metalliche.
Plexiglass base with Murano artistic glass inserts and Swarovski crystals. Stainless steel frame available in the metal finishing selection.

● [click here](#)



AIRONE VETRO

110 x 170 cm

Vetro a specchio satinato dipinto a mano. Cornice in acciaio disponibile nella selezione finiture metalliche.
Hand-painted satin mirror glass. Stainless steel frame available in the metal finishing selection

● [click here](#)



BAMBUSA

70 x 70 cm

● [click here](#)



BLACKTHORN

70 x 70 cm

● [click here](#)



JUNO

70 x 70 cm

● [click here](#)



CHRYSANTHEMUM

70 x 70 cm

● [click here](#)

Base in plexiglass madreperla con inserti in vetro artistico di Murano e cristalli Swarovski. Cornice in acciaio disponibile nella selezione finiture metalliche.
Mother-of-pearl plexiglass base with Murano artistic glass inserts and Swarovski crystals. Steel frame available in a selection of metal finishes.



AQUILA

110 x 170 cm

Vetro a specchio satinato dipinto a mano. Cornice in acciaio disponibile nella selezione finiture metalliche.
Hand-painted satin mirror glass. Stainless steel frame available in the metal finishing selection

● [click here](#)



AIRONE BLACK

110x170 cm

Vetro a specchio satinato dipinto a mano. Cornice in acciaio disponibile nella selezione finiture metalliche.
Hand-painted satin mirror glass. Stainless steel frame available in the metal finishing selection

● [click here](#)



LEOPARDO DELLE NEVI

120 x 160 cm

Vetro a specchio satinato dipinto a mano. Cornice in acciaio disponibile nella selezione finiture metalliche.
Hand-painted satin mirror glass. Stainless steel frame available in the metal finishing selection

● [click here](#)

Stampa su plexiglass con intarsi in vetro e cristalli Swarovski. In alcuni soggetti sono presenti anche inserti in madreperla. Cornice in acciaio inox lucidato, disponibile nella selezione finiture metalliche.

Print on plexiglass with inlay of Swarovski crystals and glass. According to the subject are also present mother of pearl inserts. Frame in shiny stainless steel, available in the metal finishing selection.



HYDRA

70 x 90 cm

[click here](#)



WINGED WOMAN

70 x 90 cm

[click here](#)



LADY DRAGON

70 x 90 cm

[click here](#)



LADY BUTTERFLY

160 x 120 cm

[click here](#)



ORCHIDEA LALIQUE

120 x 120 cm

[click here](#)



IRIS

140 x 140 cm

[click here](#)



COLEOTTERO

90 x 120 cm

[click here](#)

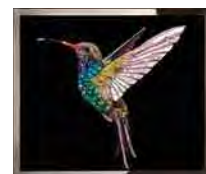

COLIBRI MINI

31 x 26 cm

[click here](#)



GUFO

26 x 31 cm

[click here](#)



COLEOTTERO AMBRA

60 x 80 cm

[click here](#)



COLEOTTERO NERO

60 x 80 cm

[click here](#)



BETTA SPLENDES

60 x 80 cm

[click here](#)



HIPPO CAMPUS

60 x 80 cm

[click here](#)



STENO

60 x 80 cm

[click here](#)



LIBELLULA

31 x 26 cm

[click here](#)



CORVO

26 x 31 cm

[click here](#)



COLEOTTERO VERDE

60 x 80 cm

[click here](#)



COLEOTTERO GIALLO

60 x 80 cm

[click here](#)



EURIALE

60 x 80 cm

[click here](#)



PUGILINA

60 x 80 cm

[click here](#)



TRITONIS

60 x 80 cm

[click here](#)

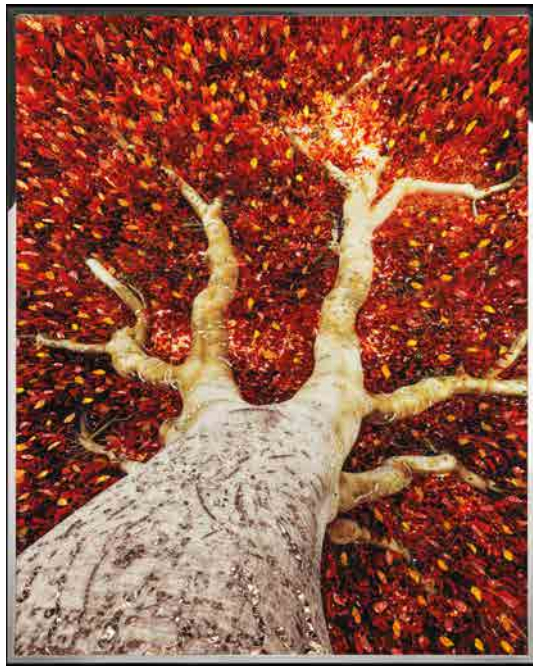

ALBERO

140 x 175 cm

[click here](#)



AXEL

CONSOLLE - CONSOLE

design La Conca

Struttura in acciaio inox lucido con profilo del top a sezione diamantata. Top in vetro incassato retrolaccato. Top Art Gallery: Soggetto Foglie. Opzione: laccatura oro/bronzo.
Polished stainless steel structure with top profiles in diamond section. Recessed top in lacquered glass. Top Art Gallery: Leaves. Option: golden/bronze lacquered.

[click here](#)



PARROT

170 x 130 cm

[click here](#)



GHEKO

100 x 160 cm

[click here](#)



RANA

120 x 140 cm

[click here](#)



LUCERTOLA

170 x 110 cm

[click here](#)



GUFO

170 x 110 cm

[click here](#)



FALCO

170 x 110 cm

[click here](#)



IGUANA

170 x 110 cm

[click here](#)

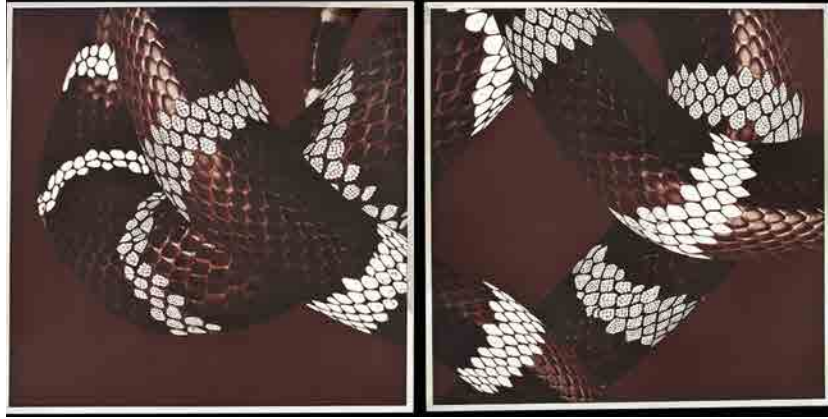

SERPENTI 1 & 2
110 x 110 + 110 x 110 cm

● [click here](#)



TREE OF DREAM
200 x 140 cm

● [click here](#)



COLIBRI BIG
140 x 140 cm

● [click here](#)



LIBRA
140 x 120 cm

● [click here](#)



PAVONE

180 x 150 cm

● [click here](#)



FENICOTTERO
160 x 140 cm

● [click here](#)



LEOPARDO
180 x 120 cm

● [click here](#)



LEOPARDO ORO
180 x 120 cm

● [click here](#)



GREEN BUTTERFLY

170 x 120 cm

● [click here](#)



RED BUTTERFLY

170 x 120 cm

● [click here](#)



FARFALLA

170 x 120 cm

● [click here](#)



CAVALLO GIOSTRA

180 x 120 cm

● [click here](#)



CAVALLO

170 x 110 cm

● [click here](#)

STONE AND STEEL



GERMANI REALI

200 x 110 cm

Base in plexiglass dipinta a mano con inserti in pietra dipinta a mano e cristalli Svarovski. Cornice in acciaio disponibile nella selezione finiture metalliche.

Hand painted Plexiglass base with inserts in hand-painted stone and Swarovski crystals. Stainless steel frame available in the metal finishing selection.

● [click here](#)



ALI

140 x 175 cm

Base in plexiglass con inserti in pietra dipinta a mano e cristalli Svarovski. Cornice in acciaio disponibile nella selezione finiture metalliche. Plexiglass base with inserts in hand-painted stone and Swarovski crystals. Stainless steel frame available in the metal finishing selection.

● [click here](#)



ROOSTER

100 x 160 cm

Base in plexiglass con inserti in vetro dipinti a mano, pietra e cristalli Svarovski. Cornice in acciaio disponibile nella selezione finiture metalliche.

Plexiglass base with inserts in hand-painted glass, stone and Swarovski crystals. Stainless steel frame available in the metal finishing selection.

● [click here](#)

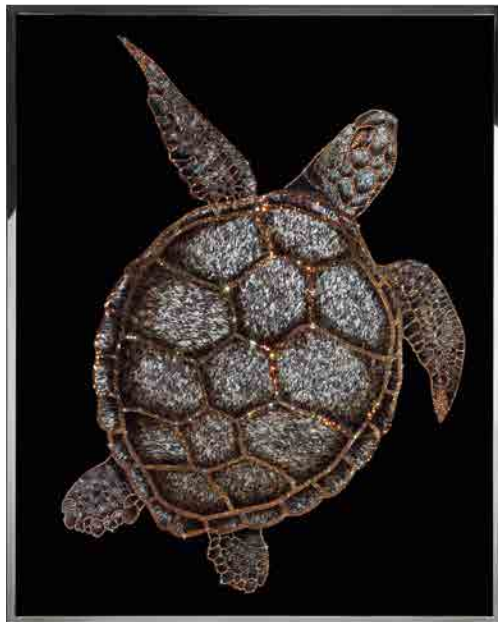

TARTARUGA

140 x 175 cm

Base in plexiglass con inserti in pietra e cristalli Swarovski.
Base in plexiglass with inserts in stone and crystals Swarovski.

[● click here](#)



LEAFS

180 x 120 cm

Base in plexiglass con inserti in pietra dipinta a mano e cristalli Swarovski. Cornice in acciaio disponibile nella selezione finiture metalliche.
Plexiglass base with inserts in hand-painted stone and Swarovski crystals. Stainless steel frame available in the metal finishing selection.

[● click here](#)



ANTILOPE

175 x 140 cm

Base in plexiglass con inserti in vetro dipinti a mano, pietra e cristalli Swarovski. Cornice in acciaio disponibile nella selezione finiture metalliche.
Plexiglass base with inserts in hand-painted glass, stone and Swarovski crystals. Stainless steel frame available in the metal finishing selection.

[● click here](#)

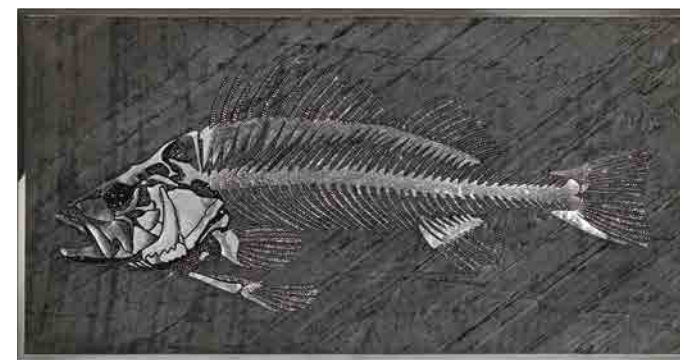

LISCA DI PESCE

180 x 94 cm

Base in acciaio con marcatura a laser, inserti in pietra e cristalli Swarovski.
Base in steel with laser finishing, inserts in stone and crystal Swarovski.

[● click here](#)



ASTRATTO

120 x 140 cm

Base in pietra con inserti in vetro. Cornice in acciaio disponibile nella selezione finiture metalliche.
Stone base with inserts in glass. Stainless steel frame available in the metal finishing selection.

[● click here](#)



PEONIA

130 x 150 cm

Base in pietra dipinta a mano con inserti in vetro e cristalli Swarovski. Cornice in acciaio disponibile nella selezione finiture metalliche.
Hand-painted stone base with inserts in glass and Swarovski crystals. Stainless steel frame available in the metal finishing selection.

[● click here](#)

FOSSIL WOOD



BEETLE/A

60 x 80 cm

● [click here](#)



BEETLE/B

60 x 80 cm

● [click here](#)



BEETLE/C

60 x 80 cm

● [click here](#)

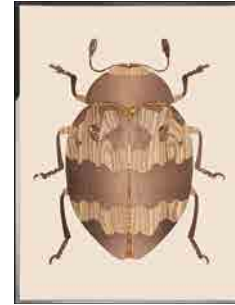

BEETLE/D

60 x 80 cm

● [click here](#)

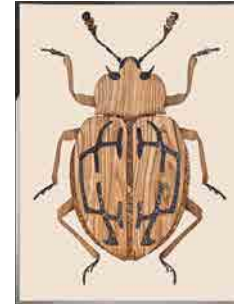

BEETLE/E

60 x 80 cm

● [click here](#)



BEETLE/F

60 x 80 cm

● [click here](#)

Base in plexiglass con inserti in legno fossile Abonos™, vetro e cristalli Svarovski. Cornice in acciaio disponibile nella selezione finiture metalliche.
Plexiglass base with inserts in fossil wood Abonos™, glass and Svarovski crystals. Stainless steel frame available in the metal finishing selection.



ROSA FOSSILE

140 x 140 cm

Base in plexiglass con inserti in legno fossile Abonos™ dipinto a mano.
Cornice in acciaio disponibile nella selezione finiture metalliche.
Plexiglass base with inserts in fossil wood Abonos™. Stainless steel frame available in the metal finishing selection

● [click here](#)

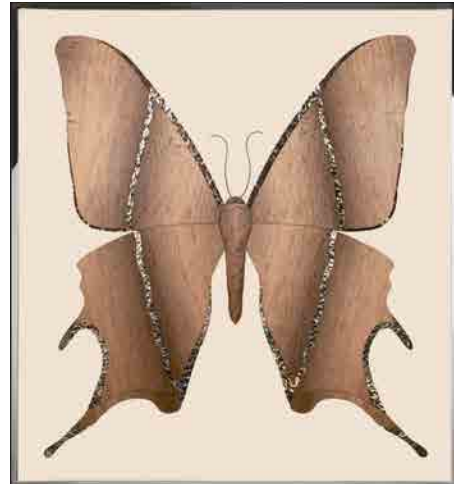

KALLIMA

130 x 140 cm

Base in plexiglass con inserti in legno fossile Abonos™, vetro e cristalli Svarovski.
Cornice in acciaio disponibile nella selezione finiture metalliche.
Plexiglass base with inserts in fossil wood Abonos™, glass and Svarovski crystals. Stainless steel frame available in the metal finishing selection.

● [click here](#)



LILIUM FOSSILE

110 x 170 cm

Base in plexiglass con inserti in legno fossile Abonos™ dipinto a mano e cristalli Svarovski.
Cornice in acciaio disponibile nella selezione finiture metalliche.
Plexiglass base with inserts in hand-painted fossil wood Abonos™ and Svarovski crystals. Stainless steel frame available in the metal finishing selection

● [click here](#)



DANAUS

160 x 130 cm

Base in legno fossile Abonos™ con inserti in madre perla, vetro e cristalli Svarovski.
Cornice in acciaio disponibile nella selezione finiture metalliche.
Base in fossil wood Abonos™ with inserts in mother of pearl, glass and Svarovski crystals. Stainless steel frame available in the metal finishing selection.

● [click here](#)

CaCO₃

Il collettivo artistico dei CaCO3 conduce una rigorosa ricerca che mette in scena molteplici e inedite riformulazioni del linguaggio del mosaico nella contemporaneità.

Le opere si presentano come superfici mosse e vibranti di tessere in vetro, talvolta colorato o inglobante la foglia d'oro, oppure in marmo o gesso. I tasselli sono disposti manualmente in uno strato di malta cementizia fresca, addizionata con ossido per ottenere diverse sfumature cromatiche. Il loro diverso configurarsi, mediante il mutare dell'inclinazione con cui sono inserite nella malta di supporto, genera con la luce effetti molteplici, di movimento, di rotazione, di modularità, di pulsazione, rendendo queste opere uniche e vive.

The CaCO3 artistic collective conducts a rigorous research that stages multiple and unedited reformulations of the mosaic language in the contemporary world.

The works are presented as moving and vibrating surfaces of glass tiles, sometimes colored or incorporating gold leaf, or marble or plaster. The anchors are disposed manually in a layer of fresh cement mortar, added with oxide in order to obtain different chromatic nuances. Their different configurations, by changing the inclination with which they are inserted in the support mortar, generates multiple light effects, of movement, rotation, modularity, pulsation, making these art works unique and alive.

MOVIMENTI

La serie "Movimento", nasce per evidenziare il rapporto luce/materia. In particolare, nei mosaici di pasta vitrea con foglia d'oro, la luce impalpabile scivola e penetra nella materia scomponendosi e ricomponendosi nella frammentazione musiva, dando la sensazione di una dimensione altra o profonda che porta la percezione in uno stato contemplativo.

The "Movimento" series was created to highlight the relationship between light and material. In particular, in the glass paste mosaics with gold leaf, the impalpable light slips and penetrates the material, breaking down and recomposing itself in the mosaic fragmentation, giving the sensation of another dimensions, a profound dimension that brings perception into a contemplative state.



MOVIMENTO n 172 - 173 - 174

80 x 10 x 5 cm (each strip)

Pasta di vetro con foglia d'oro, malta, ossido colorante, ferro su pannello alveolare.
Glass paste with gold leaf, mortar, colorant oxide, honeycomb panel, iron.

● [click here](#)



MOVIMENTO n 100

102 x 122 x 4 cm

Vetro e malta bianca su pannello alveolare, ferro zincato.
Glass and white mortar on wooden panel, galvanized iron.

● [click here](#)



MOVIMENTO n 86

100 x 100 x 8 cm

Pasta di vetro con foglia d'oro, malta, ossido colorante, ferro.
Glass paste with gold leaf, mortar, colorant oxide, iron.

● [click here](#)

CATTEDRALI

Nelle opere "Cattedrale", tutte realizzate con il vetro utilizzato per le vetrate artistiche delle chiese medievali, viene amplificato il rapporto simbiotico tra le diverse stratificazioni di un mosaico: se nelle vetrate medievali la trasparenza del vetro viene attraversata dalla luce trasfigurandola, in questo gruppo di opere il colore del sottofondo (affresco) attraversa il vetro trasparente delle migliaia di tessere colorate e si fonde con esso nell'occhio di chi guarda, oltrepassando così i limiti dello spazio interstiziale in cui era tradizionalmente relegato.

The "Cattedrale" artworks are made with the same glass used for the stained glass windows of medieval churches. In these artworks, the symbiotic relationship between the different layers of a mosaic is amplified: while in the medieval windows the transparency of the glass is crossed by the light transfiguring it, in this group of artworks the color of the background (fresco) crosses the transparent glass of the thousands colored tiles and merges with it in the eye of the beholder, thus going beyond the limits of the interstitial space in which it was traditionally relegated.

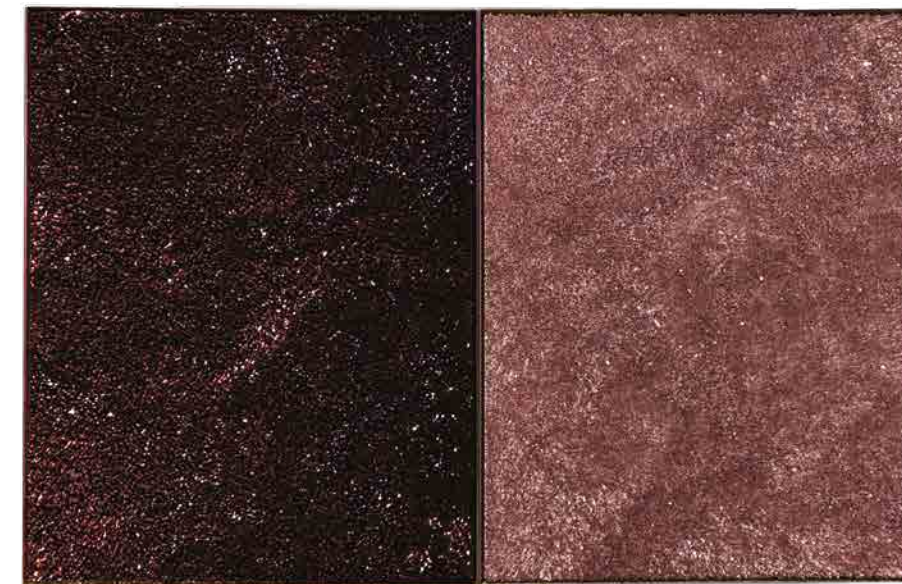

CATTEDRALE n 57 - 58

70 x 90 x 4 cm (each)

Vetro, malta, ossido minerale e ferro su pannello alveolare.
Glass, colorant oxide and mortar on honeycomb panel, iron.

● [click here](#)



CATTEDRALE n30

50 x 80 x 4 cm

Vetro, malta, pannello alveolare, ferro.
Glass, colorant oxide and mortar on honeycomb panel, iron.

[● click here](#)



CATTEDRALE n37

33 x 67 x 4 cm

Vetro, malta, pannello alveolare, ferro.
Glass, colorant oxide and mortar on honeycomb panel, iron.

[● click here](#)



CATTEDRALE n33

80 x 80 x 4 cm

Vetro, malta, pannello alveolare, ferro.
Glass, colorant oxide and mortar on honeycomb panel, iron.

[● click here](#)



CATTEDRALE n48

80 x 130 x 4 cm

Vetro, malta, pannello alveolare, ferro.
Glass, colorant oxide and mortar on honeycomb panel, iron.

[● click here](#)



CATTEDRALE n41 - 42

80 x 130 x 4 cm (each)

Vetro, malta, pannello alveolare, ferro.
Glass, colorant oxide and mortar on honeycomb panel, iron.

[● click here](#)



CATTEDRALE n21

30 x 30 x 4 cm

Vetro, malta, pannello alveolare, ferro.
Glass, colorant oxide and mortar on honeycomb panel, iron.

[● click here](#)



CATTEDRALE n27

50 x 50 x 4 cm

Vetro, malta, pannello alveolare, ferro.
Glass, colorant oxide and mortar on honeycomb panel, iron.

● [click here](#)



CATTEDRALE n54

60 x 60 x 4 cm

Vetro, malta, pannello alveolare, ferro.
Glass, colorant oxide and mortar on honeycomb panel, iron.

● [click here](#)



CATTEDRALE n29

50 x 80 x 4 cm

Vetro, malta, pannello alveolare, ferro.
Glass, colorant oxide and mortar on honeycomb panel, iron.

● [click here](#)

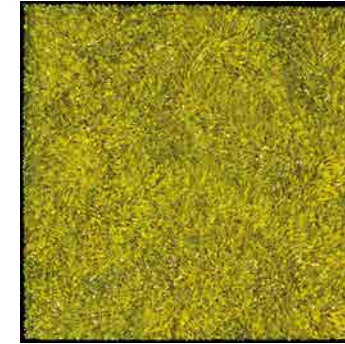

CATTEDRALE n28

50 x 50 x 4 cm

Vetro, malta, pannello alveolare, ferro.
Glass, colorant oxide and mortar on honeycomb panel, iron.

● [click here](#)



CATTEDRALE n32

80 x 80 x 4 cm

Vetro, malta, pannello alveolare, ferro.
Glass, colorant oxide and mortar on honeycomb panel, iron.

● [click here](#)



CATTEDRALE n67

150d x 6 cm

Vetro, malta, pannello alveolare, ferro.
Glass, colorant oxide and mortar on honeycomb panel, iron.

● [click here](#)



CATTEDRALE n 69

110 x 110 x 5 cm

Vetro, malta, pannello alveolare, ferro.
Glass paste, colorant oxide and mortar on honeycomb panel, iron.

[● click here](#)



CATTEDRALE n 74 - 75

130 x 160 x 5 cm (each)

Vetro, malta, pannello alveolare, ferro.
Glass, colorant oxide and mortar on honeycomb panel, iron.

[● click here](#)



CATTEDRALE n 70

110 x 122 x 4 cm

Vetro, malta, pannello alveolare, ferro.
Glass, colorant oxide and mortar on honeycomb panel, iron.

[● click here](#)



CATTEDRALE n 76

85 x 150 x 5 cm

Vetro, malta, pannello alveolare, ferro.
Glass, colorant oxide and mortar on honeycomb panel, iron.

[● click here](#)

SOFFI

Le opere della serie "Soffi" vengono sottoposte ad una sabbiatura superficiale che produce un'accelerazione di quel processo naturale di deterioramento che rende la materia viva e allo stesso tempo affascinante. Le superfici vetrose in cui si alternano stratificazioni opacizzate a quelle rilucenti diventano così spazi eterei; le superfici musive in calcare, levigate e plasmate dal soffio della sabbiatura, diventano propaggini organiche.

The artworks of the "Soffio" series are subjected to surface sandblasting that accelerates the natural process of deterioration that makes the material alive and fascinating at the same time. The glassy surfaces in which matt and shiny layers alternate become so ethereal spaces in which to immerse sensorially; the mosaic surfaces in limestone, smoothed and shaped by the breath of sandblasting, become organic offshoots like a call to life.



SOFFIO n 9

142 x 122 x 8 cm

Vetro e malta su pannello alveolare, ferro zincato.
Glass and mortar on wooden panel, galvanized iron.

● [click here](#)



SOFFIO n 34

110 x 110 x 5 cm

Vetro e malta su pannello alveolare, ferro zincato.
Stained glass, colorant oxide and mortar on honeycomb panel, iron.

● [click here](#)



SOFFIO n 28 - 29 - 30 - 31

50 x 60 x 4 cm (each)

Set 4 pezzi. Pasta vitrea con foglia d'oro bianco, malta su pannello ligneo, ferro.
Full composition of 4 pieces. Glass with white gold leaf and mortar on veneered wooden panel, iron.

● [click here](#)



SELENITE n 1

100 x 100 x 5 cm (each)

Pietra di luna, pasta di vetro con foglia d'oro bianco, malta, ossido colorante, ferro su pannelli alveolari.
Moonstone, glass paste with white gold leaf, mortar, colorant oxide, honeycomb panels, iron.

● [click here](#)



RACCORDO n 2 - 3

80 x 80 x 4 cm (each)

Vetro, oro 24K e malta su pannello alveolare.
Glass, 24K gold and mortar on honeycomb panel.

● [click here](#)



VARIABILI n 1

130 x 150 x 4 cm

Vetro, malta, pannello alveolare, ferro.
Glass, colorant oxide and mortar on honeycomb panel, iron.

[● click here](#)



VARIABILI n 2

130 x 150 x 4 cm

Vetro, malta, pannello alveolare, ferro.
Glass, colorant oxide and mortar on honeycomb panel, iron.

[● click here](#)

VARIANTI COLORE

Possibilità di varianti colore e dimensioni a richiesta.
Possibility of colour and size variants on request.



AMBRA



BLUE



CERULEO



CORALLO



DEEP BLUE 1



GIALLO



NERO



PRUGNA



ROSA



ROSA ANTICO



ROSSO RUBINO



TRASPARENTE
CRISTALLINO



TRASPARENTE
GRIGIO



TRASPARENTE



TURCHESE



VERDE CHIARO



VERDE
DEGRADÈ

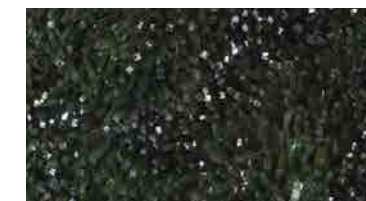

VERDE MUSCHIO
9 TINTE



VERDE MUSCHIO
BRILLANTE



VERDE MUSCHIO
STRIATO



VERDE

PATRIZIA ZAMMARCHI

Dopo l'esperienza di direttore creativo e designer free lance per il settore moda e pelletteria, Patrizia Zammarchi indirizza la sua competenza per le tecniche del ricamo verso il mondo della fine art e dell' interior design. Dalla passione per la fotografia e dalla rielaborazione delle stesse con tecniche diverse nascono le serie The sleeping flowers e Floralia.

After her experience as a creative director, and as a freelance designer, in the field of fashion and leather goods, Patrizia Zammarchi applies her passion and expertise in embroidery to the world of fine art and interior design. The sleeping flowers and Floralia series are born from her passion for photography and the reworking of the same with different techniques.

THE SLEEPING FLOWERS

Le opere prendono vita da scatti fotografici, focalizzati sui dettagli dei soggetti, per ottenere inquadrature di immagini inusuali. Ad un' attenta elaborazione digitale stampata su raso che esalta e ammorbidisce le forme creando sapienti e calibrate mescolanze di colori e tonalità, segue il ricamo eseguito rigorosamente a mano da alcuni dei migliori artigiani del mondo tessile.

The works come to life from photographic shots, focusing in particular on the details of the subjects, to obtain shots of images that are unusual. A careful digital processing, which, together with printing on satin, enhances and softens the shapes, creating skilful and calibrated blends of colours and shades is followed by the embroidery, absolutely handmade by some of the best craftsmen in the textile world, considered to be among the finest masters of this art.

FLORALIA

Derivazione della serie de I fiori addormentati, anche Floralia trae ispirazione dal mondo fantastico del vegetale. Mantiene le caratteristiche di realizzazione della serie precedente, ma questa volta, ad immortalare i soggetti, l'occhio irreali di un caleidoscopio che crea proporzioni ed effetti da giungla urbana.

Derived from 'The Sleeping Flowers' series, Floralia too draws inspiration from the fantasy world of plants. It retains the realization characteristics of the previous series, but this time, to immortalise the subjects, the unreal eye of a kaleidoscope that creates proportions and effects of an urban jungle.



HYDRANGEA

76 x 70 x 5 cm

Quadro di fiori di Hydrangea elaborati digitalmente, stampati su tessuto di raso con preziosi inserti di ricamo fatti a mano. Cornice in plexiglass.
Digitally processed Hydrangea flowers picture, printed on satin fabric with precious handmade embroidery inserts. Frame in plexiglass.

● [click here](#)



DEEP BLUE

100 x 70 x 5 cm

Immagine di fiori elaborata in caleidoscopia digitale, stampata su tessuto di raso con preziosi inserti di ricamo fatti a mano. Cornice in plexiglass.
Digitally kalendoscropy processed flowers picture, printed on satin fabric with precious handmade embroidery inserts. Frame in plexiglass.

● [click here](#)



PEONIES

90 x 70 x 5 cm

Quadro di fiori di Peonie elaborati digitalmente, stampati su tessuto di raso con preziosi inserti di ricamo fatti a mano. Cornice in plexiglass.
Digitally processed Peonies flowers picture, printed on satin fabric with precious handmade embroidery inserts. Frame in plexiglass.

● [click here](#)



WILD GREEN

100 x 70 x 5 cm

Immagine di fiori elaborata in caleidoscopia digitale, stampata su tessuto di raso con preziosi inserti di ricamo fatti a mano. Cornice in plexiglass.
Digitally kalendoscropy processed flowers picture, printed on satin fabric with precious handmade embroidery inserts. Frame in plexiglass.

● [click here](#)

ART DESIGN |

ART DESIGN |

ART DESIGN |

ART DESIGN |

ART DESIGN |

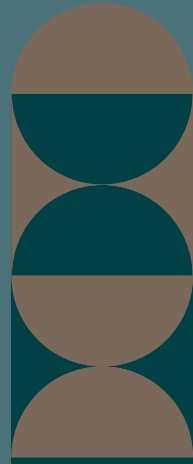



PAVONE

TRONO - THRONE
Marc Ange

Trono in pelle o tessuto, scocca in ottone e acciaio, braccioli e schienale composti da una corolla di elementi in ottone fuso e lucidato a mano con cuscinetti imbottiti e rivestiti. Elementi decorativi retro schienale in ottone curvato e lucidato a mano con cuscinetti imbottiti. Seduta e poggiatesta in poliuretano a densità differenziate e falda acrilica. Basamento in legno rivestito in pelle e base in metallo cromato. Le parti in metallo sono disponibili nella selezione finiture metalliche.

Throne in leather or fabric, external structure in brass and steel, armrests and backrest consist of elements shaped like a corolla of petals, made in cast brass with hand-polished finish and with upholstered pads. Decorative elements behind the backrest made in curved brass with hand-polished finish and equipped with upholstered pads. Seat and small back cushion padded in polyurethane foam with different densities and acrylic fibre. Lower seat structure in wood, covered in leather, and base in chromed metal. Metal parts can be lacquered in any colour included in the metal finish selection.

Pezzo unico in 3 varianti cromatiche.

Unique piece in 3 color variants.

Winner of the 2020 Archiproducts Design Awards, "Furniture" category

● click here

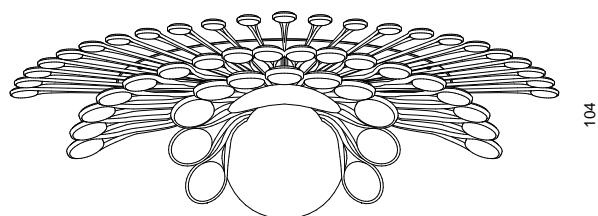
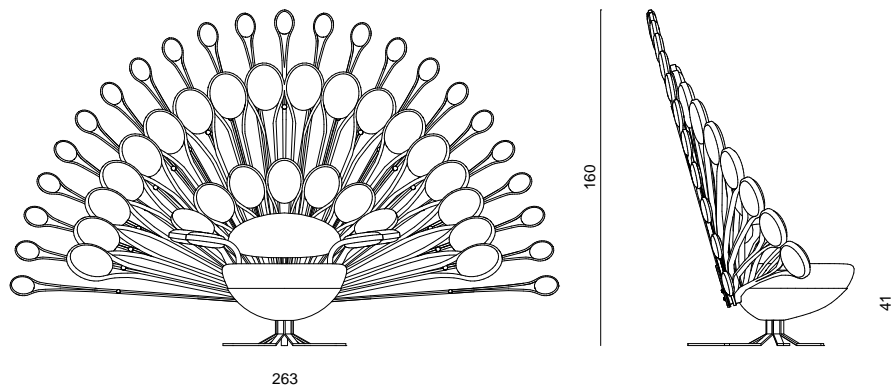

PAVONE

POLTRONA ALTA - HIGH ARMCHAIR
Marc Ange

Poltrona alta in pelle o tessuto, scocca in ottone e acciaio, braccioli e schienale composti da una corolla di elementi in ottone fuso e lucidato a mano con cuscinetti imbottiti e rivestiti. Seduta e poggiatesta in poliuretano a densità differenziate e falda acrilica. Basamento in legno rivestito in pelle e base in metallo cromato. Le parti in metallo sono disponibili nella selezione finiture metalliche.

High armchair in leather or fabric, external structure in brass and steel, armrests and backrest consist of elements shaped like a corolla of petals, made in cast brass with hand-polished finish and with upholstered pads. Seat and small back cushion padded in polyurethane foam with different densities and acrylic fibre. Lower seat structure in wood, covered in leather, and base in chromed metal. Metal parts can be lacquered in any colour included in the metal finish selection.

● click here

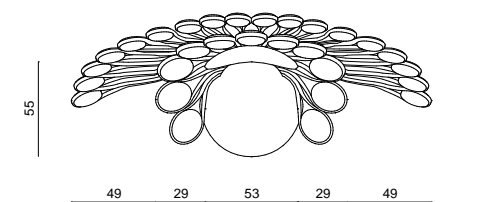
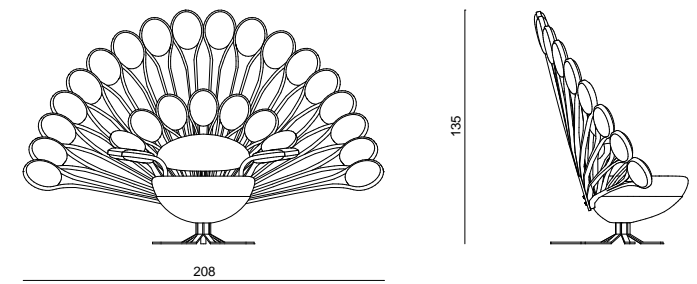

PAVONE

POLTRONA - ARMCHAIR

Marc Ange

Poltrona in pelle o tessuto, scocca in ottone e acciaio, braccioli e schienale composti da una corolla di elementi in ottone fuso e lucidato a mano con cuscinetti imbottiti e rivestiti. Seduta e poggiatesta in poliuretano a densità differenziate e falda acrilica. Basamento in legno rivestito in pelle e base in metallo cromato. Le parti in metallo sono disponibili nella selezione finiture metalliche.

Armchair in leather or fabric, external structure in brass and steel, armrests and backrest consist of elements shaped like a corolla of petals, made in cast brass with hand-polished finish and with upholstered pads. Seat and small back cushion padded in polyurethane foam with different densities and acrylic fibre. Lower seat structure in wood, covered in leather, and base in chromed metal. Metal parts can be lacquered in any colour included in the metal finish selection.

● [click here](#)

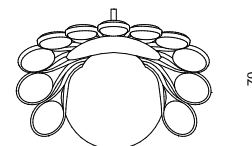
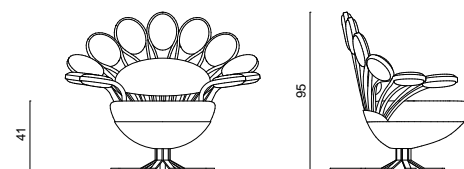



ASTRID

SEDIA - CHAIR

Alessandro La Spada - Domenico Greci

Sedia imbottita con scocca in legno curvato e rivestita in pelle dipinta a mano con inchiostro dall'artista Domenico Greci. Gambe in fusione di alluminio satinato disponibile nella selezione finiture metalliche.

Una serie di ritratti di donna, un omaggio alla bellezza femminile. Per la manualità dell'intervento pittorico ogni sedia è da considerarsi pezzo unico.

Upholstered chair with structure in curved wood and upholstered in leather hand-painted in ink by artist Domenico Greci. Satin-finish cast aluminium legs available in a selection of metal finishes.

A series of portraits of women, a tribute to feminine beauty. For the dexterity of the pictorial intervention, each chair is to be considered a unique piece.

vedi anche/see also ASTRID sedia-chair, ASTRID dehors

● [click here](#)

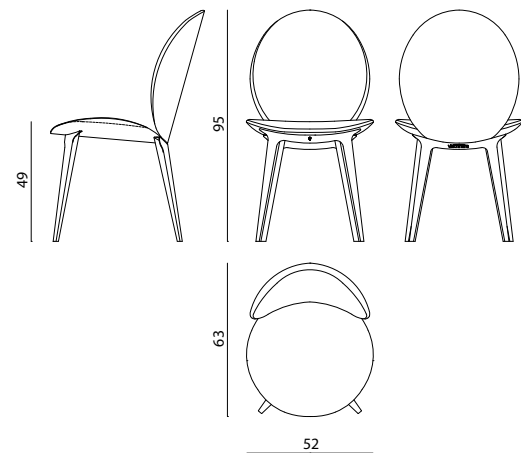

VENUS VEILED

SCULTURA PER ARMADIO - SCULPTURE

Alessandro La Spada

Scultura in blocco di marmo Rosa Portogallo, fresato e finito a mano con inserti in semipreziosi. Basamento in acciaio lucidato, disponibile nella selezione finiture metalliche. Edizione limitata e numerata di 10 pezzi.

Sculpture in Rosa Portogallo marble block, milled and finished by hand with semi-precious stone inserts. Polished steel base, available in a selection of metal finishes. Limited and numbered edition of 10 pieces.

vedi anche/see also LEONARDO armadio-wardrobe

● [click here](#)

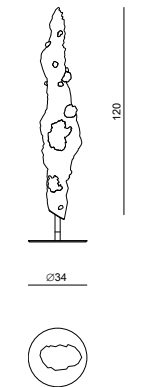



Produced by
©IPE SRL
ALL RIGHTS RESERVED

Visionnaire Logo, catalogue and advertising images are sole propriety of IPE srl, henceforth any use of the logo or adaptation of images is strictly forbidden without IPE srl prior approval; nonetheless, in any case the images must be used in such a way that there is no reasonable doubt that those belong to IPE srl and refer to IPE srl products. No part of this publication can be reproduced or transmitted in any form or by any means, both electronic or mechanical, including photocopying and recording, or via any information storage and retrieval system, without written permission of the publisher.

Made in Italy | July 2022

Art Director Eleonore Cavalli

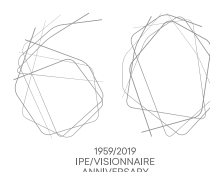

The year 2019 was one of anniversaries for IPE-Visionnaire: the mother company IPE celebrated the 60th anniversary, while Visionnaire, its exclusive brand, its 15th birthday.

Creatività, sostenibilità e meta-luxury.
La Re-Evolution dal cuore verde di Visionnaire passa anche dalla realizzazione di questo catalogo che unisce il valore storico dell'italianità del brand alla green consciousness. L'intero catalogo è stampato su carte ricavate da fonti gestite in maniera responsabile.

*Creativity, sustainability and meta-luxury.
Visionnaire green-hearted re-evolution hits also the production of this catalogue, in which the long standing value of the company for made-in-Italy melts with the concept of green consciousness. The catalogue is printed on paper obtained from responsibly managed sources.*

I.P.E. S.r.l.
Via Mattei 1 - 40069 Zola Predosa (Bo) Italy
tel. +39 051 6186311 - fax +39 051 6186310
www.visionnaire-home.com
ipe@ipe.it

Certificazioni relative a I.P.E. S.r.l.



The mark of
responsible forestry

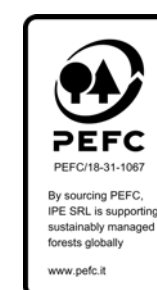

Prodotti certificati FSC™ su richiesta

■ HOME PHILOSOPHY ■
visionnaire



